

Vacuum Technology for Handling – Perfected by Rexroth



Move more with less air. Energy-efficient vacuum technology from Rexroth

If you know a subject inside out, you are in the best position to deal with outside pressure. Vacuum systems are ideal to move objects precisely and reliably, while being gentle and efficient – provided you know how to do it. Our vacuum technology combines perfect components with an optimum system layout.



Best in class in all respects

A systematic approach with many benefits

There are good arguments, both technical and economical, for using vacuum technology for your handling tasks. For many applications it may even be the only reasonable method for automation, as it is both powerful and sensitive, making it ideal for moving hard-to-grip or extremely fragile workpieces in a safe and gentle manner. An extensive range of configurable components makes vacuum technology one of the most flexible options – the perfect way to implement individual handling solutions with comparably little effort for planning and assembly.

- ▶ Versatile, flexible technology for use in many industries and applications
- ▶ Handling of a wide variety of objects, materials, and shapes
- ▶ Gentle handling without any mechanical stress on the workpiece



Industry expertise

Our combination of technical and industry expertise makes all the difference. Together with our customers, we have expanded our know-how and developed our product range to exactly meet the needs of their respective industries. The result? Products, systems, and complete solutions that are best in class in all respects and exactly fit your needs. Talk with one of our industry experts available throughout the world.



Perfect individual components are one prerequisite – technical system expertise is another. Rexroth can offer you both at the highest possible level.

04 Basics of vacuum technology

06 Vacuum components

- 06 Suction grippers
- 08 Mounting elements and flow valves
- 10 Vacuum generators
- 12 Non-contact gripping
- 13 Vacuum sensors and displays
- 14 Filters and connection elements

16 System layout

Reliably working with vacuum demands specialized expertise. Vacuum technology is unique and follows specific scientific laws.

What is a vacuum?

According to its definition, a vacuum is a “space empty of matter” with an absolute pressure of 0 bar = absolute vacuum. However, an absolute vacuum is just a theoretical state that cannot be produced on earth. In general, for technical purposes any negative deviation from the normal atmospheric pressure of 1.013 bar is considered an underpressure or vacuum and is usually given in -bar or as a relative percentage.

Relative/absolute value

Vacuum handling generally uses the relative value of a vacuum, which indicates the relation to the respective ambient pressure. The starting point for the ambient pressure is zero. Therefore, a vacuum of 60 % at sea level (atmospheric/ambient pressure = 1.013 bar) equals a vacuum of approx. -0.6 bar or an absolute pressure of approx. 0.4 bar.

Atmospheric effect on vacuum technology

The altitude of the production location is an important factor for determining the right layout of vacuum components. The ambient pressure decreases by approx. 12.5 mbar for every 100 m increase in altitude; the achievable vacuum value and possible holding force of a suction gripper decreases proportionately. At a height of 2,000 m above sea level, the ambient atmospheric pressure is only 0.763 bar. Here, a degree of vacuum of 60 % will only create a vacuum of approx. -0.45 bar or an absolute pressure of approx. 0.3 bar.

What is the relationship between pressure and force?

Whether pressure or vacuum, both produce forces that can be used for handling tasks. Force is always the product of pressure and effective surface area:

$$F = p \times A; F = \text{force}, p = \text{pressure}, A = \text{area.}$$

As the factor p in vacuum applications is limited to the level of the ambient pressure the holding force must be adjusted via the surface area parameter.

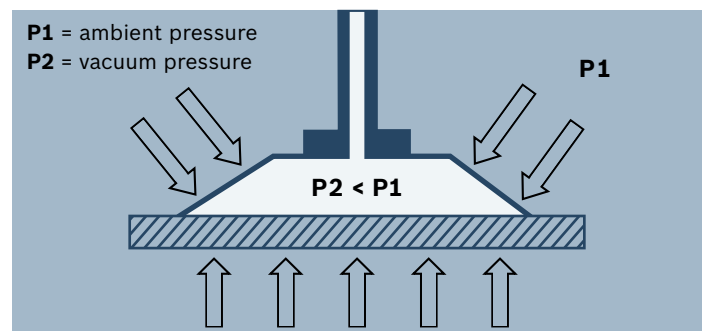
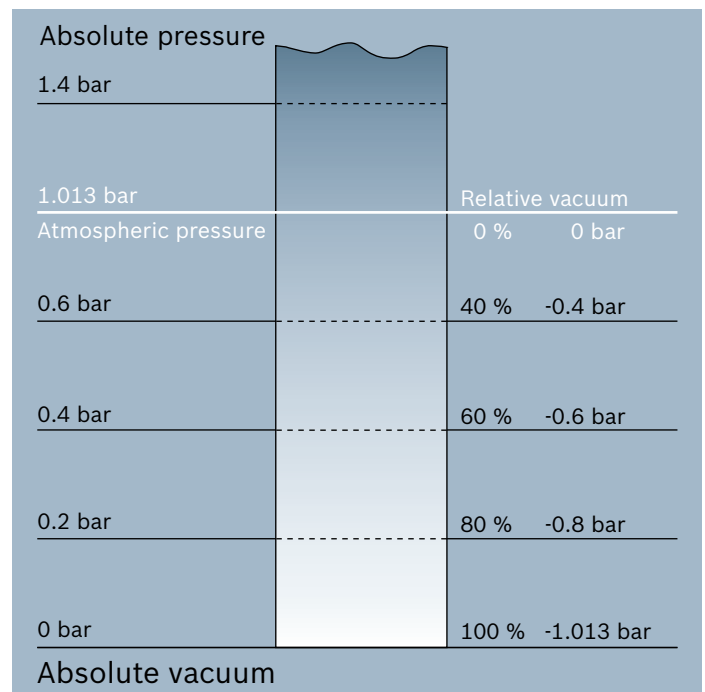

The holding force is proportional to the degree of vacuum and the surface area of a suction gripper. For example, a suction gripper with 16 mm diameter with a 60 % vacuum at an atmospheric pressure of 1.013 bar, produces a holding force of 8 N. It is also important to take into consideration that force decreases at higher altitudes. At 2,000 m altitude, the holding force in this example would drop by about 25 % to around 6 N.

Energy required for vacuum generation

The energy required to generate a high vacuum increases disproportionately to the achieved degree of vacuum. Increasing the vacuum from 60 % (-0.6 bar) to 90 % (-0.9 bar) results in an increase in force by a factor of 1.5, but the energy requirement increases by a factor of 3. In order to achieve the optimum and most efficient working range, the degree of vacuum should be a maximum of 80 %:

- ▶ For dense surfaces 60 % to 80 %
- ▶ For porous surfaces 20 % to 60 %

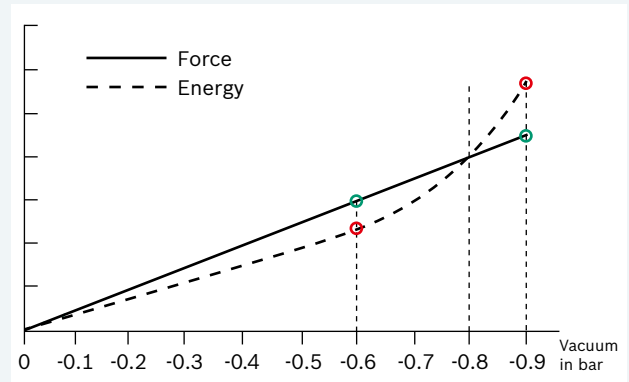

Vacuum ranges:

The level of the vacuum required depends on the application. A relatively low vacuum, or rough vacuum, is sufficient for vacuum handling. The pressure range of a rough vacuum is from -1 mbar to -0.9 bar.

The following table compares the values for absolute and relative pressure.

Vacuum/pressure conversion table								
Absolute res. press. [mbar]	Relative vacuum	bar	N/cm ²	kPa	atm, kp/cm ²	mm H ₂ O	Torr; mm Hg	in Hg
900	10 %	-0.101	-1.01	-10.1	-0.103	-1030	-76	-3
800	20 %	-0.203	-2.03	-20.3	-0.207	-2070	-152	-6
700	30 %	-0.304	-3.04	-30.4	-0.31	-3100	-228	-9
600	40 %	-0.405	-4.05	-40.5	-0.413	-4130	-304	-12
500	50 %	-0.507	-5.07	-50.7	-0.517	-5170	-380	-15
400	60 %	-0.608	-6.08	-60.8	-0.62	-6200	-456	-18
300	70 %	-0.709	-7.09	-70.9	-0.723	-7230	-532	-21
200	80 %	-0.811	-8.11	-81.1	-0.827	-8270	-608	-24
100	90 %	-0.912	-9.12	-91.2	-0.93	-9300	-684	-27

Units for pressure and vacuum:

The units pascal [Pa], kilopascal [kPa], bar [bar] and millibar [mbar] are the most accepted units for vacuum technology.

Vacuum/pressure conversion table							
	bar	N/cm ²	kPa	atm, kp/cm ²	mm H ₂ O	Torr; mm Hg	in Hg
bar	1	10	100	1.0197	10197	750.06	29.54
N/cm ²	0.1	1	10	0.1019	1019.7	75.006	2.954
kPa	0.01	0.1	1	0.0102	101.97	7.5006	0.2954
atm, kp/cm ²	0.9807	9.807	98.07	1	10332	735.56	28.97
mm H ₂ O	0.0001	0.001	0.01	0.0001	1	0.074	0.003
Torr; mm Hg	0.00133	0.01333	0.1333	0.00136	13.6	1	0.0394
in Hg	0.0338	0.3385	3.885	0.03446	345.4	25.25	1

Technical symbols:

Symbols are often used in vacuum technology for specific parts or components.

Below is an overview of a few of the most important Rexroth symbols:

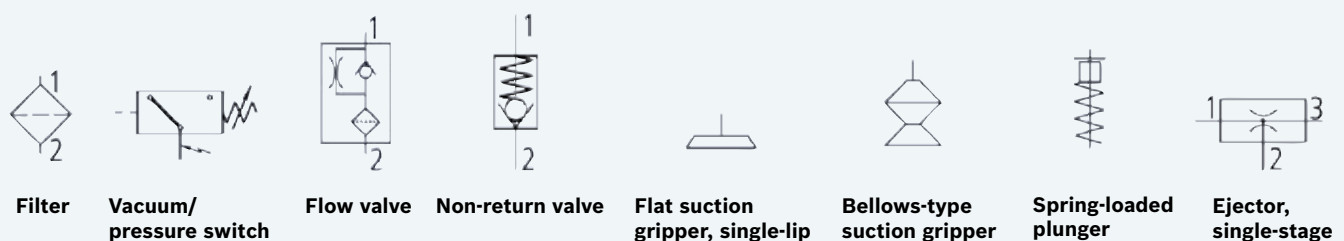

Suction grippers for safe and gentle handling – Rexroth covers the whole spectrum

They should get a grip on everything – both powerfully and gently. They must not only be the perfect fit for the individual shape, surface, and material, but must also guarantee the required holding force throughout the entire process. This notion might be difficult to grasp, but they can do it!



Flat suction gripper (round)



Flat suction grippers (oval)



Bellow suction grippers

How does a suction gripper work?

The special shape and material of a suction gripper create an almost air-tight connection with the workpiece. Once a vacuum is created in the interior volume of the suction gripper, the ambient pressure pushes the workpiece up against the gripper. It is therefore not suctioned up, but instead is pressed against the gripper by the outside pressure.

Specific shapes and sizes

A comprehensive range of shapes and sizes is needed in order to optimally cover all the requirements for vacuum handling. We differentiate between flat suction grippers and bellow suction grippers. Flat suction grippers come in a round or oval shape and bellow suction grippers have 1.5 or 2.5 bellows. Almost any application can be covered as we offer diameters and sizes ranging from 1 to 300 mm.

The right material

Proper function depends just as much on the right suction gripper material as on its shape and size. Or, more specifically, the right combination and adaptation to the workpiece, working environment, and the movement required.

A lot has to be taken into consideration when selecting the right suction grippers for your application, including wear, flexibility, indentation characteristics, suitability for use with food, and performance under extreme temperatures.

The right suction gripper for the respective application

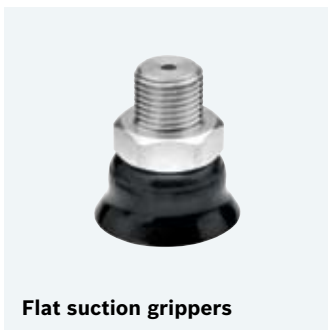

Flat suction grippers

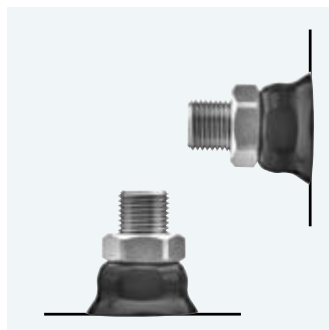

Flat suction grippers

Flat suction grippers can be used for movements requiring high transverse forces and exceptional positioning accuracy. Their low-profile design, resulting in a low interior volume, enables a minimum suction time and the best inherent stability during operation. Typical applications include handling of flat or slightly curved surfaces, such as metal sheets, cardboard, glass panels, plastic parts, or wooden boards.



Bellow suction grippers



Suction grippers 1.5 and 2.5 bellow

Bellow suction grippers enable exact adjustment to uneven surfaces and particularly gentle pick-up of sensitive workpieces and materials. They can also compensate for height differences and provide an additional lift effect during the suction process. Typical applications include handling of curved and uneven workpieces such as tubes, cardboard boxes, electronic components, die-cast parts, as well as packaged or shrink-wrapped products.

Important values and information:

Theoretical suction force

Value in N with a vacuum of -0.6 bar.

Transverse force

Measured value in N with a vacuum of -0.6 bar.

Interior volume

To determine the overall volume of the gripper system.

Radius of curvature

Radius up to which the workpiece can be gripped.

Suction lift

Lift effect produced by the suction gripper during the suction process.

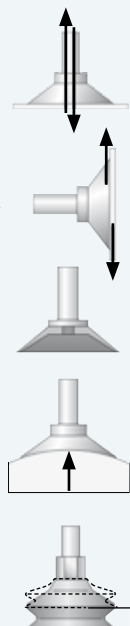

Selection of suction gripper materials based on strain

Strain (resistance to media with more or less aggressive properties)	Acrylonitrile butadiene rubber (NBR)	Fluoromethyl silicone (silicone)	Polyurethane (Vulkolan)	Chloroprene rubber (CR)	Hydrogenated acrylonitrile butadiene rubber (HNBR)
Wear	••	•	••••	••	•••
Deformation	••	••	••	••	••
General weathering	••	••••	••••	••••	••••
Ozone	•	••••	••••	••••	••••
Oils	••••	•	•••	•••	••••
Fuel	••	•	••	•	••
Alcohol	••••	••••	••••	••••	••••
Solvents/vapors	••	••	•	••	••
General acids	•	•	•	••	•
Resistance to tearing	••	•	••••	••	••
Working temperature °C	-10/+70	-30/+180	-40/+80	-10/+70	-20/+130
Shore hardness ISO 7619-1	40 – 90	55 – 60	72 ± 5	60 ± 5	70 ± 5

• = poor to satisfactory •• = good ••• = very good •••• = excellent

Rigid, spring-loaded, jointed, or with an integrated flow valve – the right choice makes all the difference

Mounting elements provide suction grippers with the necessary stability and support them during their work. They also ensure that the grippers are properly positioned so that they can use their strength to the fullest extent. When put together, they form a well-trained team that can take on the most varied tasks.

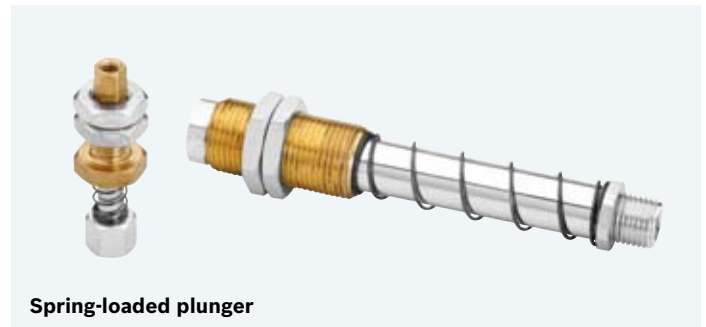

Suction gripper matrix with rigid fittings for handling cardboard boxes



Suction gripper with spring-loaded plunger and angle joint mounting for angled support of workpieces

It all depends on the application

Our comprehensive range of mounting elements covers all applications and suction grippers. Mounting elements are not only used to attach suction grippers, but also provide additional elementary functions. There are generally three options for mounting suction grippers in a vacuum system – with rigid fittings, with spring-loaded plungers, or with angle joints.



Angle joint

- ▶ **Rigid**
Rigid fittings are the right solution if you want to move flat parts that are resistant to bending. They ensure precise load guidance and a high positioning accuracy.
- ▶ **Spring-loaded**
Spring-loaded plungers are primarily used to even out height differences in workpieces and parts. Thanks to integrated compensating springs, they can be used to gently handle sensitive workpieces and surfaces through cushioned contact.
- ▶ **Jointed**
Angle joint connections are used to adapt the suction gripper to surface inclinations. An all-round, articulated support of suction grippers makes it possible to handle angled workpieces. Early release of the suction gripper due to an unbalanced load is reliably prevented.

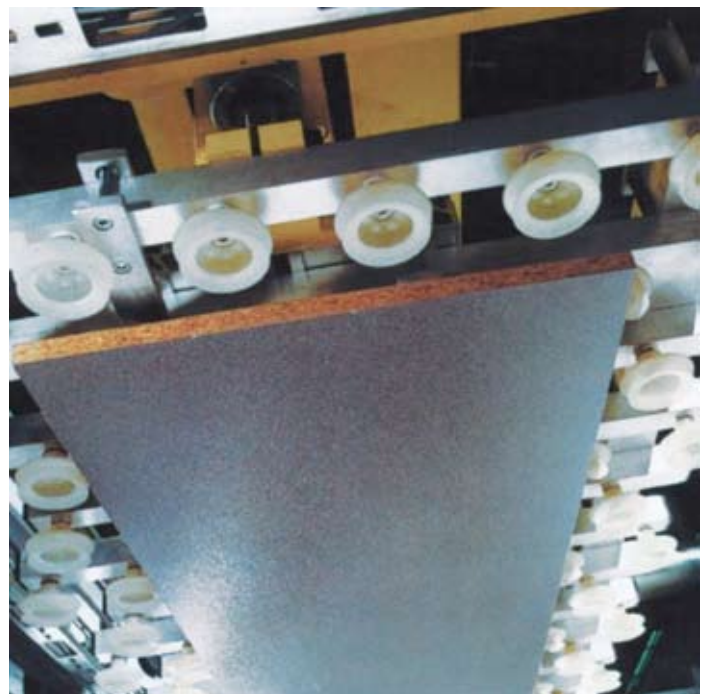

Flow valves offer even more reliability and efficiency
Flow valves contribute to the security of vacuum circuits. If a leak occurs by the workpiece disengaging from the suction gripper, the flow valve shuts off automatically. In addition, flow valves make it possible to efficiently handle workpieces with variable dimensions as the flow valve on the unused suction grippers automatically shuts off the flow.



Flow valves

How much vacuum do you need? Our program offers the optimum solution for all your applications

The same applies to vacuum as almost everything else in the world. You not only need the right quantity, but also the right quality – on the one hand, the suction capacity that can be generated and, on the other, the desired degree of vacuum. Rexroth offers the ideal combination of both in its universal ejectors.

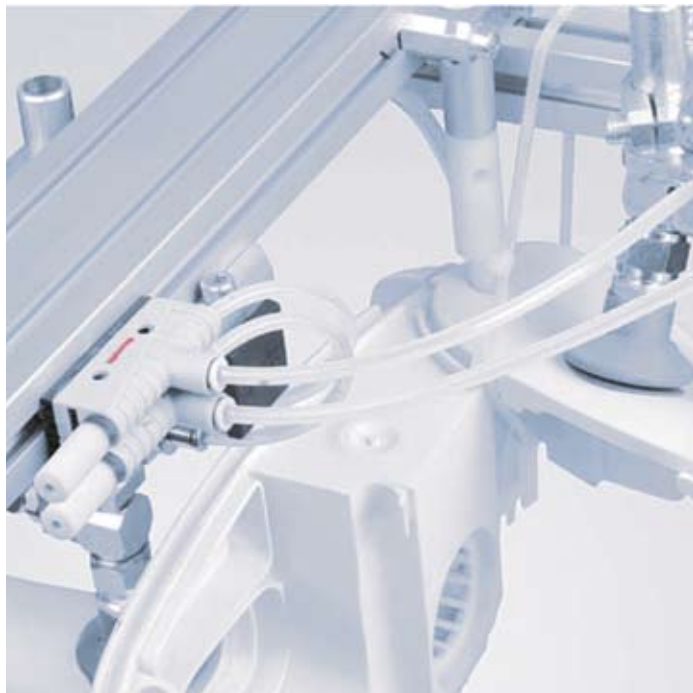

As varied as your applications

Our program spans everything from simple inline ejectors to ejectors directly mounted in the tubing connection of the suction gripper, plus decentralized compact ejectors with fully integrated, additional functions and air economizers. The suction capacity ranges from 6 to 600 l/min.

Various methods for vacuum generation

There are three different methods to generate a vacuum: using electric pumps, electric blowers, or pneumatically-operated ejectors. Ejectors are relevant for pneumatic applications because of the required suction capacity and the high degree of vacuum they can achieve. Depending on the application, you can use single-stage or multistage ejectors with different features. These are compact, light weight, can be easily integrated into the system, generate a vacuum quickly, are almost wear-free, and very maintenance-friendly.

▲ **Handling a plastic housing. Directly-mounted basic ejectors and bellow suction grippers for uneven surfaces.**

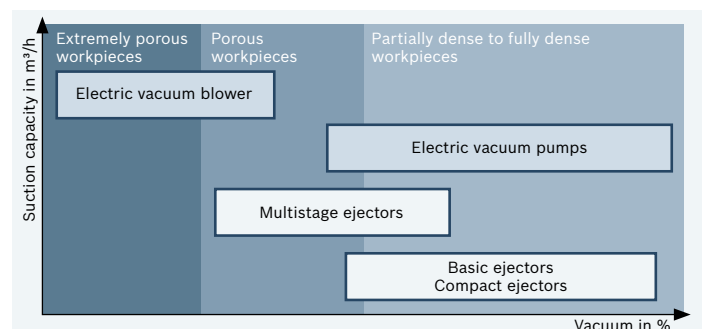

Optimized ejector technology for higher energy efficiency

Vacuum using the Venturi principle

Our pneumatically-driven vacuum ejectors operate via the Venturi principle. One or more inline Venturi nozzles form the core of the ejectors. The guided compressed air flows through the nozzle, where it is accelerated and compressed. The accelerated air expands directly after the Venturi nozzle, which creates a low pressure so that air is sucked in through the vacuum connection. The intake air and compressed air then escape through silencers.

Inline ejectors

Inline ejectors have been designed with an axial compressed air and vacuum connection for direct installation in the vacuum line.

Compact ejectors

Several functions are integrated into a single unit in our compact ejectors. These include vacuum generation, control valves, filters, switches, and silencers.

Ejectors with air economizers

Our air economizers help you save up to 85 % of the compressed air energy! An integrated solenoid valve is used to directly control the vacuum generator.

- ▶ After the ejector has been activated, the compressed air remains on only until the required vacuum has been generated.
- ▶ The compressed air valve stays closed as long as the vacuum value remains within the desired set points.
- ▶ The ejector does not need any compressed air during this phase.

Multistage ejectors

Multistage ejectors can achieve an enormous suction capacity through the use of several Venturi nozzles connected in series.

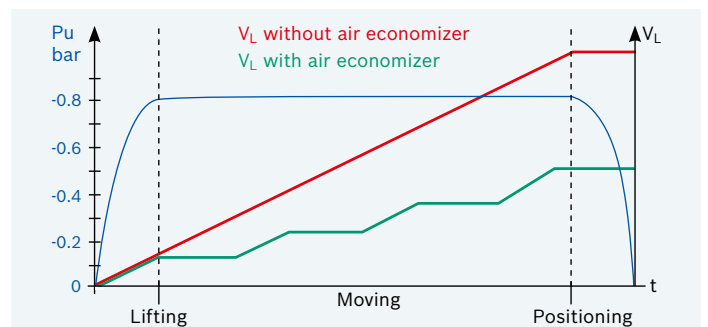
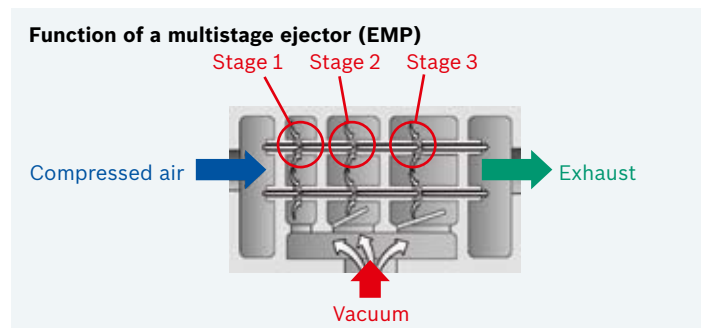
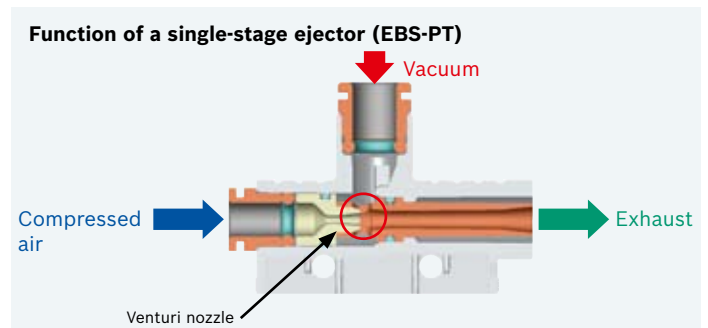

The most gentle method for handling – gripping highly-sensitive objects and surfaces

Non-contact transfer (NCT)

Our non-contact transfer system offers a very special type of handling. Objects and workpieces with a weight of up to almost one kilogram can be lifted and moved without touching the surfaces.

- ▶ Lifting force using the Bernoulli principle
- ▶ The air stream under the gripper generates a differential pressure
- ▶ The workpiece is raised by the lifting force

To optimize the system and for use in specific tasks, NCT grippers have been designed with special details, which have expanded the application range. For example, a mechanical connection with the workpiece is required in order to transfer the lateral forces. This can be achieved using integrated pads or, as an alternative, with a guide on the sides of the workpiece.

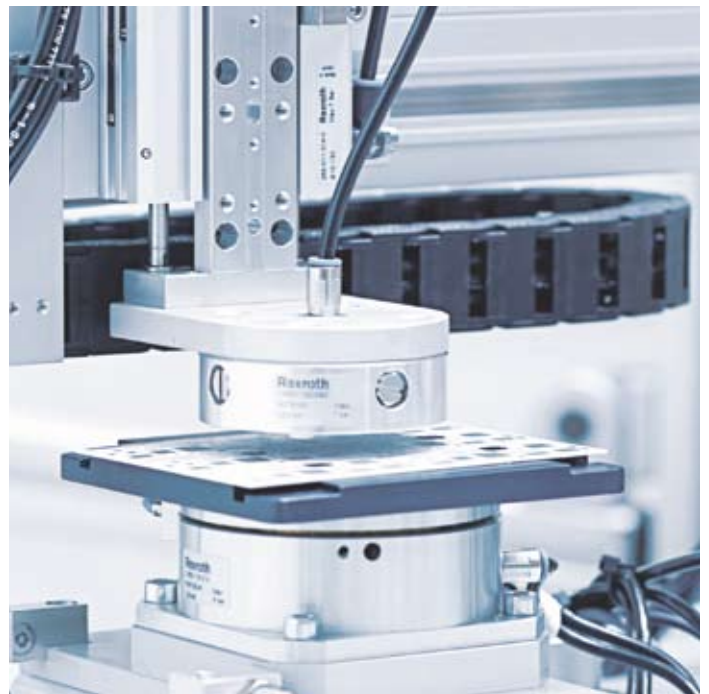

NCT principle of operation

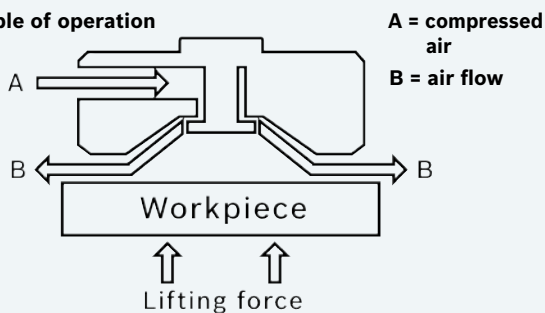

▲ In the 18th century, Daniel Bernoulli discovered that an increase in the speed of a flowing liquid is accompanied by a drop in pressure.



NCT

◀ NCT series non-contact grippers are ideal for handling sensitive surfaces and hard-to-grip materials.

NCT series

The NCT transport unit is available in four sizes with diameters ranging from 20 to 60 mm. Air is supplied via an M5 air connection in the center or on the side. The suction/gripping force is from 0.2 to 9 N.

Keeping tabs on everything – the right sensor components for the highest process reliability

Although trust is good, it is sometimes better to keep an eye on everything, because knowledge is power! A well-functioning system must also provide you with the opportunity to respond appropriately to changing factors. One prerequisite for this is to always have an overview of all the important parameters.

Essential for the safe operation of a vacuum system

Pressure gauges, electromechanical pressure switches or electronic pressure sensors – the individual components for system monitoring may be very varied, but they all use their respective functions to perform the same tasks:

- ▶ Monitoring and regulation of the vacuum system
- ▶ Possibility to detect errors
- ▶ Constant information on the state of the system
- ▶ Targeted increase in process reliability

In addition to basic system monitoring, other features concentrate on optimizing cycle times, control loops, and energy-saving devices. Our comprehensive range includes the right components for all applications and even specific tasks.

Pressure switches and pressure sensors

Extremely compact pressure switches and sensors can be easily integrated into existing machines and programmed for specific functions. This includes converting the pressure signals into electric or pneumatic signals, separately programmable digital outputs, hysteresis and switching points with extremely high switching precision, repeatability, and high switching frequencies – basically everything required to make the application even better. All from Rexroth.



Pressure sensors



Pressure switch



Pressure gauges

Pressure sensor

Putting it all together – the right accessories to make your system complete

Accessories. Sometimes it's the little things that make all the difference. And not just as a small necessity, but as a major feature with important functions. Just like a chain is only as strong as its weakest link, a closed system is only as good as each of its individual elements.



▲ **Highly-dynamic, clean, and reliable handling for CD/DVD production using vacuum components and accessories with minimized dimensions.**

Protection from contamination and outside influences

The special vacuum filters in our program optimally protect the vacuum generator from contamination and damage caused by outside influences. They can be installed as pre-filters or microfilters to combat various levels of contamination. Different designs are also available to fit varying tasks and configurations. The inline vacuum filters for vacuum systems with low to medium levels of contamination and so-called vacuum filter cups with



Vacuum filter

additional features are available in a wide range of sizes. The level of contamination can be easily seen from outside thanks to transparent housings and filter cups.

- ▶ Efficient operation with a long service life
- ▶ Large range of sizes
- ▶ Filtering of vacuum and compressed air up to 7 bar
- ▶ Easy installation and filter exchange

Secure fittings

In addition to Rexroth's standard fittings with tube nuts, push-in fittings have become widely accepted in vacuum technology.

- ▶ Optimum sealing with a captive O-ring
- ▶ For tubing diameters from 3 to 16 mm
- ▶ In plastic, metal, and stainless steel versions
- ▶ Straight, angled, T/Y/X form, multiple connections

**Push-in fittings****Tubing available in all sizes and materials**

We have a wide range of tubing to fit all applications and operating conditions. Dimensions, material, and design: Nothing is left to be desired! We have it all – tubing for extremely high flows, tubing resistant to aggressive media, tubing for daily use in the food industry, or completely anti-static tubing for explosive atmospheres.

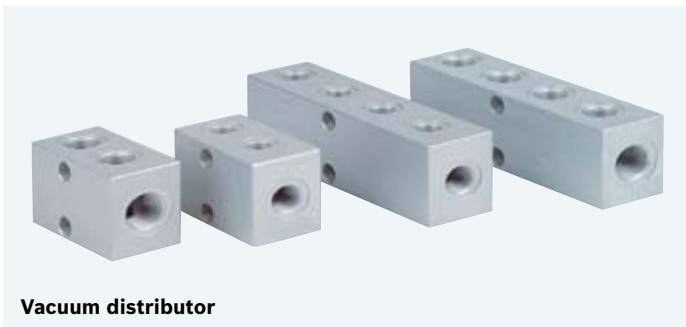
**Connecting tubing****Vacuum distributor****Vacuum distributors**

Special aluminum distributors with integrated mounting options are used for targeted distribution of compressed air and vacuum. They are used to disperse the vacuum in systems with several suction grippers and central vacuum generation.

**Vacuum tweezers**

Rexroth has also developed standardized sub-systems. Vacuum tweezers, for example, have been proven to be an extremely powerful instrument for manually handling tiny components and extremely sensitive, high-tech end products. They are gentle, clean and get right to the point.

Vacuum system layout

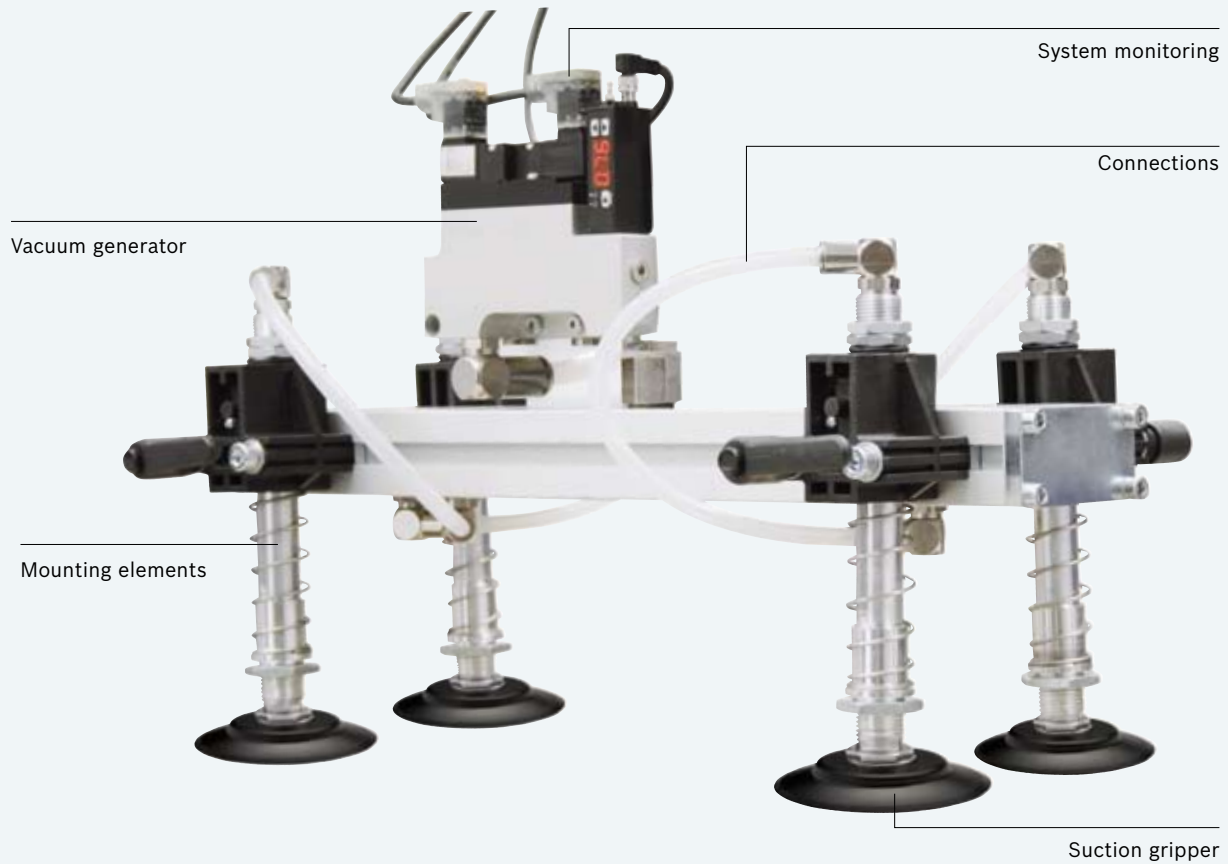

The required gripping force

Load case 1: Horizontal suction gripper, vertical force

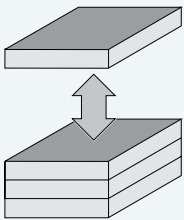

Load case 2: Horizontal suction gripper, horizontal force

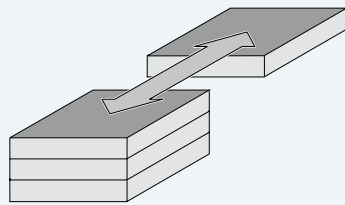

Load case 3: Vertical suction gripper, vertical force

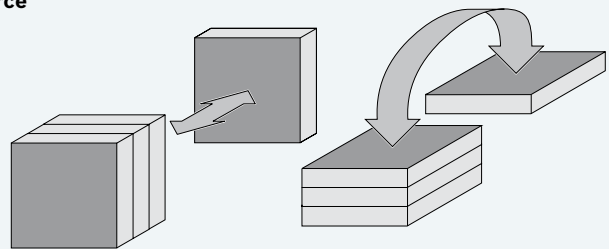

Theoretical holding force

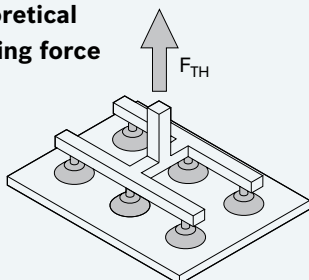

Calculation of the theoretical holding force F_{TH}

Example with load case 2

Given:

- m** Load mass (steel plate) = 60 kg
- g** Force of gravity [9.81 m/s²]
- a** Max. acceleration of the moved mass = 5 m/s²
- μ** Friction coefficient = 0.5 (only with load cases 2 and 3)
- S** Safety factor = 2

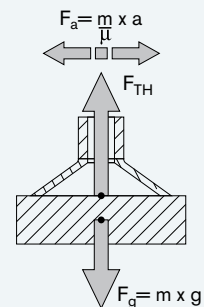

As individual as your application. An optimum system layout in 7 steps.

Let us put your team together! With excellent players assigned to all the right positions and a tactical plan for all the tasks. This is the way to efficiently save energy. Your team will work together successfully and will even have enough energy to go into overtime.

1. Workpiece information

Determining the characteristics of the workpiece to be moved is always the first step and a prerequisite for an optimum vacuum system layout. Parameters to be taken into account include:

- ▶ Workpiece material (metal, plastic, wood, glass, ceramic, cardboard, etc.)
- ▶ Workpiece properties (airtight, porous, flexible, hard, soft)
- ▶ Weight, mass, and dimensions of the workpiece
- ▶ Surface finish (smooth, rough, slightly rough, sensitive, structured)
- ▶ Temperature range (min./max. working temperature)

2. Define the required gripping force

Values of the mass and acceleration forces are required in order to define the holding forces that the suction grippers must withstand and work with. The type of movement and

the associated work for the gripper system are also important for this calculation. The three most common load cases are illustrated in the graphic.

Safety factor S

The calculation of holding force always remains a theoretical consideration. In practice, other factors in the work environment, as well as the workpiece's surface properties, may affect this calculation. For this reason, we recommend including a safety factor $S \geq 2$ in your calculation.

Holding force per suction gripper F_s

The required holding force F_{TH} can be distributed over several suction grippers. The number of suction grippers (n) here depends on the shape, size, and bending stability of the workpiece.

$F_s = F_{TH}/n$; in load case 2 with 6 suction grippers:

$$F_s = 2377.20 \text{ N}/6 = 396.20 \text{ N}$$

Theoretical holding force, example with load case 2:

Horizontal suction gripper surface, horizontal holding force F_{TH}

$$F_{TH} = m \times (g + a/\mu) \times S$$

$$F_{TH} = 60 \text{ kg} \times (9.81 + 5/0.5) \text{ m/s}^2 \times 2$$

$$F_{TH} = 2377.20 \text{ N} [\text{kg} \times \text{m/s}^2]$$

More information:

www.boschrexroth.com/pneumatics-catalog

>> Technical information

Friction factor μ Workpiece	Friction factor
Plexiglas	0.45 – 0.7
Hard rubber	0.6 – 1
Particle board	0.7
Cardboard	0.5 – 0.75
Wood, metal, glass, steel	0.5
Rough surface	0.6
Wet surface	0.25
Oily surface	0.1

Component selection

3. Select the right suction grippers

The most important selection criteria include the information on the workpiece and the required gripping force. The work environment conditions must also be taken into account:

- ▶ Suction gripper form (oval or round flat suction grippers, bellow suction grippers with 1.5 or 2.5 bellows)
- ▶ Number of suction grippers (dependent on the workpiece material, weight, dimensions, bending stability)
- ▶ Suction gripper material (in accordance with the application, load, workpiece surface)
- ▶ Suction gripper type (series, diameter, suction force)

4. Select the mounting elements

Selecting suitable mounting elements depends on the selected suction grippers and application specifications. For example, an angle joint is required for uneven or inclined surfaces. A spring-loaded plunger is needed to compensate for height tolerances.

5. Dimension the tubing diameter

In addition to selecting the right tubing material, correct dimensioning of the tubing connections is also important. The tubing diameter depends on the suction gripper diameter and the required flow.

6. Calculate the volume to be evacuated

The entire volume to be evacuated in the vacuum system must be calculated in order to select the best ejectors, particularly in applications with short cycle times. This includes all the spaces in the individual elements that contain air, from the suction grippers on the workpiece to the tubing connected to the vacuum port of the ejector. The total volume of air to be evacuated is the sum of all the individual volumes calculated when dimensioning.



7. Select the vacuum generator

In addition to the application specifications, the required suction capacity of the ejector must be calculated by adding up the required suction capacities of all the suction grippers used in the system. The required suction capacity per suction gripper is dependent on the size and type. If the evacuation time is of importance, the volume to be evacuated is then added to your calculation.

Working together to configure your application

Take advantage of our service – in person or online

We are constantly in direct dialog with our customers and are always a competent contact partner for both technical and economical questions. The same applies when configuring your vacuum application. In addition to the information offered in the Internet, you have access at all times to the technical and industry expertise of our consultants.

Comprehensive information on our Internet platform

The Rexroth Internet portal is available round the clock and supports you in all areas of the business process – from configuration through to the delivery. Our online catalog provides all the product details and the technical information contains important data on product functions and parameters. We also offer a unique calculation program to lay out suction grippers, allowing you to create your own basic configurations with just a few clicks of the mouse.

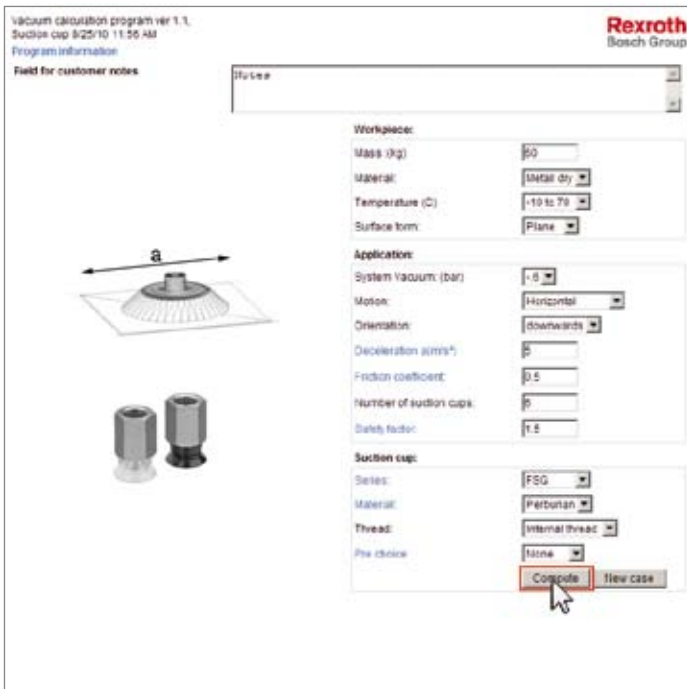
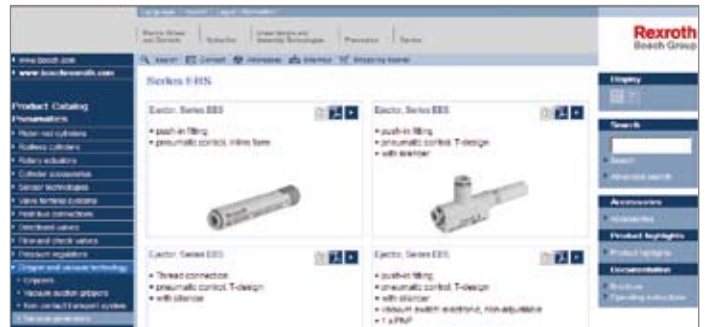

R499050834/12.2009 | Technical Information Pneumatics | Bosch Rexroth AG 223/266

Gripper and Vacuum Technology | Vacuum technology

3.2.7 Calculation of total volume V_G to be evacuated

The total volume V_G to be evacuated is necessary for the optimized cycle time design of the vacuum generator.

$$V_G = V_1 + V_2 + V_3 + V_4 + V_5$$

- V_G = Evacuating total volume
- V_1 = "Suction gripper" volume (information can be found in the product catalog)
- V_2 = "Mounting elements" volume
- V_3 = "Hoses" volume
- V_4 = "Fittings" volume
- V_5 = "Distributors, pre-filters, valves, etc" volume

ENGLISH

Bosch Rexroth AG

Pneumatics
Ulmer Straße 4
D - 30880 Laatzen
Phone +49 511 2136-0
Fax +49 511 2136-269
sales-pneumatics@boschrexroth.de
www.boschrexroth.com/pneumatics

Canada

Bosch Rexroth Canada Corp.
3426 Mainway Drive
Burlington, Ontario L7M 1A8
Tel. +1 905 335-5511
Fax +1 905 335-4184

Australia

Bosch Rexroth Pty. Ltd.
3 Valediction Road
Kings Park NSW 2148
Sydney
Tel. +61 2 9831-7788
Fax +61 2 9831-5553

U.S.A.

Bosch Rexroth Corp.
1953 Mercer Road
Lexington, KY 40511-1021
Kentucky
Tel. +1 859 254-8031
Fax +1 859 254-4188

Great Britain

Bosch Rexroth Ltd.
Broadway Lane
South Cerney
Cirencester, GL7 5UH
Gloucestershire
Tel. +44 1285 86-3000
Fax +44 1285 86-3003

Further contacts:

www.boschrexroth.com/addresses

The data specified above only serve to describe the product. No statements concerning a certain condition or suitability for a certain application can be derived from our information. The given information does not release the user from the obligation of own judgement and verification. It must be remembered that our products are subject to a natural process of wear and aging.