

**Assembly technology
modular, ergonomic,
connected**

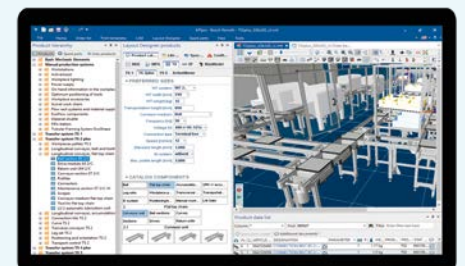

Assembly technology by Rexroth – everything you need for efficient production

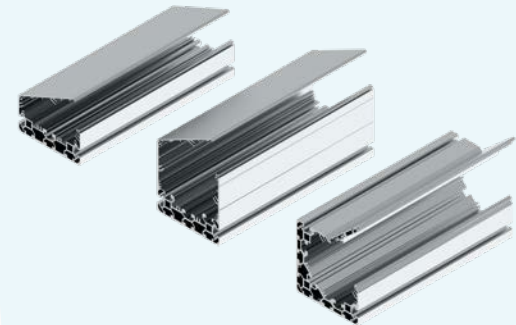
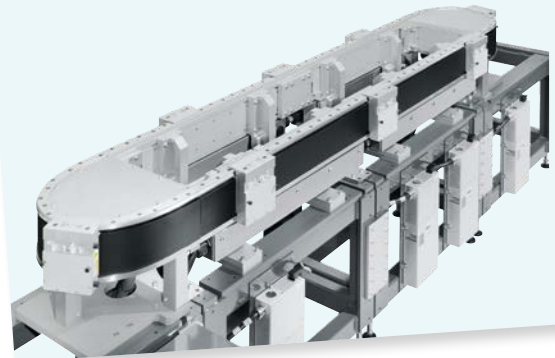

**WE MOVE.
YOU WIN.**



ASSEMBLY TECHNOLOGY OVERVIEW

- 4 Bosch Rexroth
 - 6 Product overview
 - 8 Customer orientation and industry expertise – our experience gives you a leg-up
-

PRODUCT LINES

- 10 Aluminum Structural Framing**
 - 12 Safety with the system
 - 13 Aluminum strut profiles
 - 14 Connection technology, *designLINE* version
 - 16 Accessories, Quick & Easy profile finishing
 - 18 EcoSafe protective fence
 - 19 Function-integrated profiles
 - 20 Manual Production Systems**
 - 22 Workstations, swivel work chairs
 - 24 Workstation lighting
 - 25 Drawer cabinet range
 - 26 On-hand information
 - 27 Tool storage
 - 28 Electric case lifter
 - 29 Lean/Xlean flow rack systems
 - 30 FiFo station and material shuttles
 - 31 EcoFlow linking elements
 - 32 EcoShape tubular framing system
 - 33 Grab containers
 - 34 Material and information flow technology**
 - 36 ACTIVE Mover transfer system
 - 38 TS 1 transfer system
 - 40 TS *2plus* transfer system
 - 42 TS *2plus* booster
 - 43 FTS – Flexible transport system
 - 44 TS 5 transfer system
 - 46 TS *2pv* transfer system
 - 48 VarioFlow *plus* chain conveyor system
 - 50 ID 200, ID 15 identification systems
 - 52 Service for ACITVE Mover, TS transfer systems, and VarioFlow *plus***
 - 56 Intralogistics**
 - 56 ACTIVE Shuttle autonomous transport system
 - 58 ROKIT locator
 - 60 MT*pro* planning software**
 - 62 FRAME*pro* CAD plug-in**
 - 64 Tightening Technology**
 - 64 Platform 350 tightening systems
 - 66 Bosch EXACT and C-EXACT tools
 - 68 Service for tightening systems
 - 70 Service**
-

SUPPLEMENTARY INFORMATION

- 72 Customer-specific solutions and projects

Use us to take the lead – as soon as tomorrow

When it comes to driving, controlling and moving, companies around the world rely on Rexroth's expertise. A one-of-a-kind, comprehensive range of interconnecting technologies, the key role in Industry 4.0 solutions and in-depth industry expertise have made us the leader in numerous sectors.

i4.0
CONNECTED
INDUSTRY

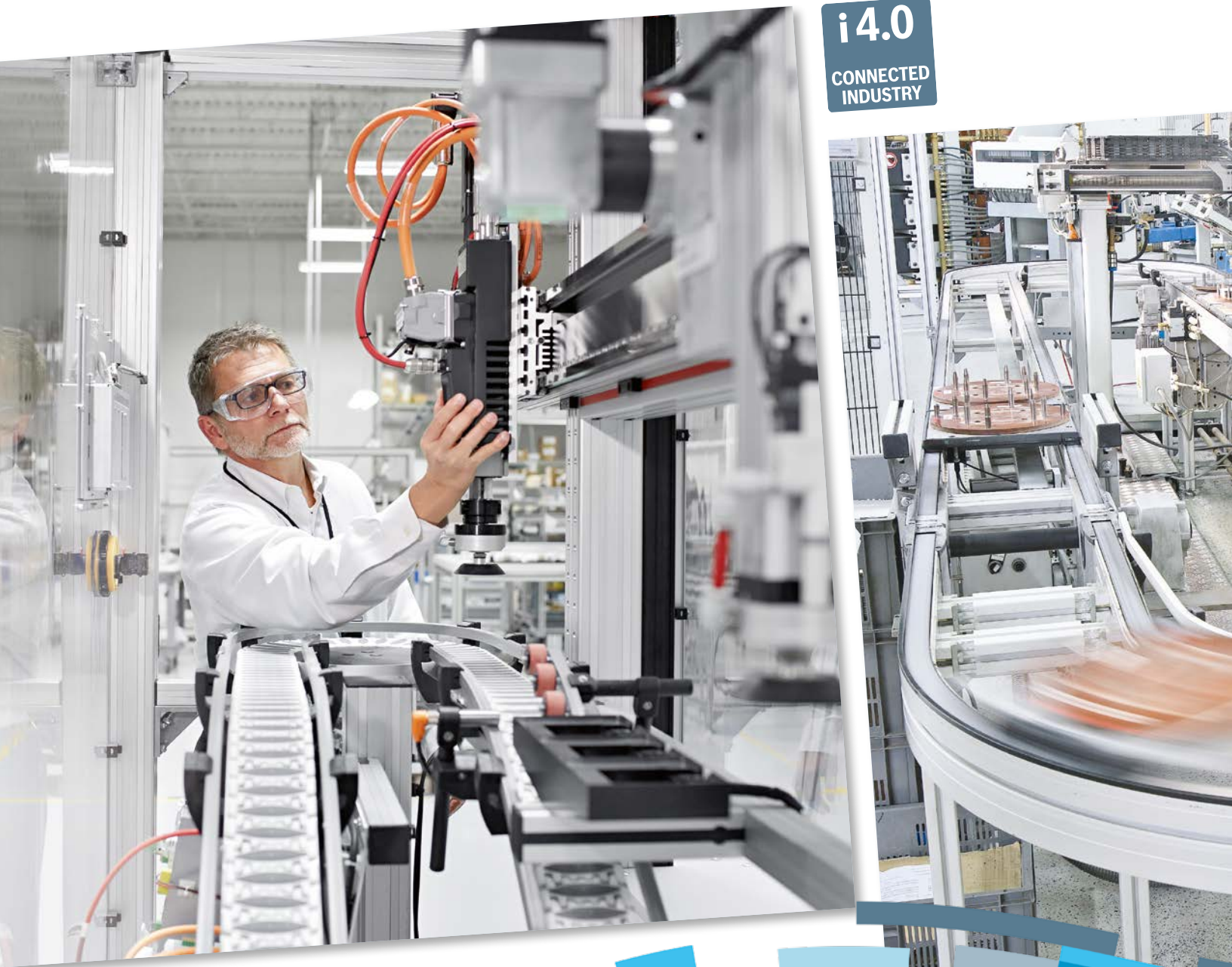

However, close partnerships with our customers which are based on mutual trust and transparency in all processes are much more important to us. This is how we take the lead together.



Everything we do is aimed to meet the specific requirements of our customers. In cooperation with our partners, we support you in designing and planning ergonomic and efficient assembly systems to ensure lean production. Whatever the application area, we always work together with you to find the most practical and future-proof solution – from tried and tested standard designs to a customized, fully connected high-end system that can still be modernized and scaled or connected to new data structures, even after many years.

We think in terms of integration and interconnectability. We act with focus on solutions, performance and results. Flexibility, energy efficiency and sustainability are decisive factors in our forward-looking strategy.

Transportation solutions for all requirements

With our versatile assembly technology, we develop sustainable solutions to meet your particular needs, drawing from our years of extensive experience in production across a wide range of industries. You benefit from the advantages of our unique, comprehensive product range of components for driving, controlling and moving.



What's special about our approach? Every technology used interacts perfectly across the system thanks to its integrated applications – from the electric drives and controls to the hydraulics, down to the linear motion and assembly technology. Only Rexroth offers this kind of complexity, allowing our customers to always take the lead, anywhere.

Perfect for your requirements – anything is possible

Product life cycles continue to shrink in many industries. Innovations are ready for serial production faster than ever. Assembly technology has to keep up with the increasing speed of development and production. Flexible solutions that can be converted or expanded easily and without a lot of work are in demand, even – or especially – in times of Open Standards, IoT or Connected Automation. Make yourself ready today with assembly technology by Rexroth.



SUSTAINABLY EQUIPPED FOR A FAST-PACED MARKET

-  Quickly and easily scalable system solutions
-  Short, efficient project planning process with the user-friendly MTpro software
-  Modular system for rapid implementation
-  Standard systems and custom solutions
-  Comprehensive Industry 4.0 portfolio

Integrating versatility as early as the planning stage

You can use our complete range of systems that has been under continuous development, expansion and optimization for many years to cover a wide spectrum of requirements. You also benefit from our leading role as a market operator and user in Industry 4.0.

From manual to fully automated

Years of experience in assembly technology and detailed industry knowledge let us create economic and productive systems in no time. From the ergonomic manual workplace to the fully automated Industry 4.0 production system, we provide a tailored solution to achieve your goals quickly, reliably and safely.



Depending on the annual production quantity, a different degree of automation may be recommended. We help you find the best system to meet your needs, from basic elements, such as enclosures and work tables, to individually configured transfer systems, chain conveyor systems and identification systems.

Higher productivity, less effort

Finely coordinated, individual components and integrated systems work perfectly together, simplifying even the development and design process.

Lean production for higher efficiency

Lean, waste-free production begins with the efficient, low-waste planning of production lines tailored according to customer requirements. Activities that do not add value are minimized continuously.

Ergonomics increase performance

Ergonomically designed workstations and user-friendly production systems ensure that your employees can efficiently manage and focus on workflows.

Ideal for ESD, cleanrooms or dry rooms

We meet the requirements of special production conditions, such as those found in ESD-sensitive, cleanroom and dry room environments. Contact us directly for product details.

Networking for greater transparency

The fusion of production IT and enterprise IT, the synchronization of processes and machines that autonomously make decisions in real time all allow for efficient and customized manufacturing.

Customer orientation and industry expertise – our experience gives you a leg-up

Customer relationships couldn't be more dynamic: Bosch Rexroth maintains close relationships with mechanical and equipment engineers who develop and construct powerful all-in-one solutions for their customers using our components. At the same time, we directly assist end users in expanding their systems with single components or entire assemblies, meaning they benefit both from the equipment manufacturer's expertise and from direct support from the assembly technology experts at Rexroth.

Short planning and implementation times

Even if manufacturing conditions need to be adapted quickly to meet new demands, changes to products are underway or different lot sizes are needed – Rexroth assembly technology and the MTpro planning software help you set up your system for new processes in no time. The tremendous dynamics of the market demand the necessary manufacturing systems be implemented immediately after they are acquired. Rexroth helps you achieve this with short delivery times and rapid, uncomplicated startup. The finely coordinated system components are installed and ready for use in no time.

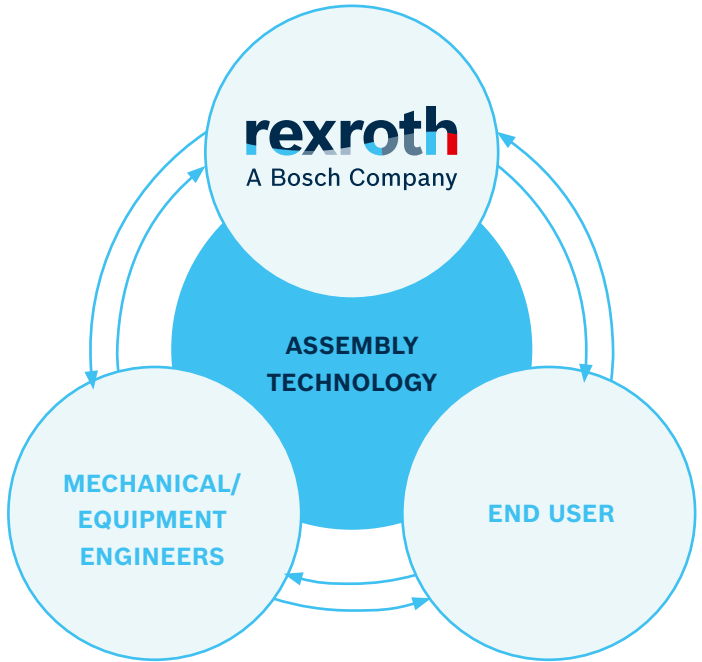

Productivity

Minimal assembly effort, perfect interaction of all components, and the ease of use of Rexroth systems lay an excellent foundation for efficient, time-saving and resource-saving production.

Always ready for something new

Shorter product life cycles require versatile assembly technology. The Rexroth modular system allows for quick and cost-efficient modification for manufacturing the next generation of a product.





Track production flow

We provide the systems (e.g. RFID) you need for tracking products and production data in detail, allowing you maximum transparency for optimal quality management.

Energy efficiency

A broad range of innovative drive and control concepts covers virtually every need in the widest variety of industries. All systems interact with one another perfectly and are designed from the start based on Rexroth's 4EE principle for maximum productivity with the least amount of energy possible.

**ASSEMBLY TECHNOLOGY –
RIGHT AT HOME IN MANY INDUSTRIES**

Complete line of products and systems available globally through subsidiaries and sales partners for

- Automotive
- Battery production
- Electrical and electronics industry
- Consumer goods manufacturing
- Mechanical engineering
- Medical technology and pharmaceutical industry
- Assembly and handling
- Food industry
- Solar panel manufacturing
- Packaging industry
- And many more!



Aluminum Structural Framing – the versatile comprehensive range

The assembly system from its inventor – uncompromising flexibility. The more precisely work environments are tailored to their specific application, the more efficient they are. Rexroth's flexible assembly system offers a quick and complete solution to every task in your industry.



Launched over 30 years ago, the Rexroth modular aluminum structural framing system for assembly technology is continuously being expanded and optimized. It currently consists of over 1,500 components for every area of production: from simple frames to enclosures, to standard and special-purpose machinery, to ESD-compatible systems and manual workstations or material supply and linking lines.

The basics of the system are impressively simple: plain, yet extremely sturdy aluminum profiles with an “unending” longitudinal slot. Together with the free MTpro planning software and our comprehensive service, the aluminum structural framing system offers everything you need to design efficient work environments.

Aluminum strut profiles

With its broad selection of profile cross-sections, Rexroth's modular aluminum strut profile system is the most comprehensive and versatile of its kind in the world. Along with the basic elements, you can create frames, enclosures, protective fences and work tables with minimal planning required. Every component is extremely sturdy and corrosion-resistant.

The modular profile system becomes even more flexible when used with the EcoShape tubular framing system for features such as workstations, flow racks or material shuttles.

Connectors and accessories

A multitude of different connection elements make practically anything possible when implementing your custom system, and make your flow racks, enclosures or workstations fully ESD-compatible. The profiles can be delivered cut to length and finished, saving you serious implementation time.

Quick & Easy profile finishing

Thanks to 500,000 options, features such as holes, recesses, threads and miter cuts can be included with ease. The Quick & Easy configuration tool for our eShop or the MT*pro* planning software lets you plan your custom profile finishing. In addition to the order string, you can get a CAD model or dimensional drawing. Then just submit your order and receive your delivery in no time.

BENEFITS FOR YOU

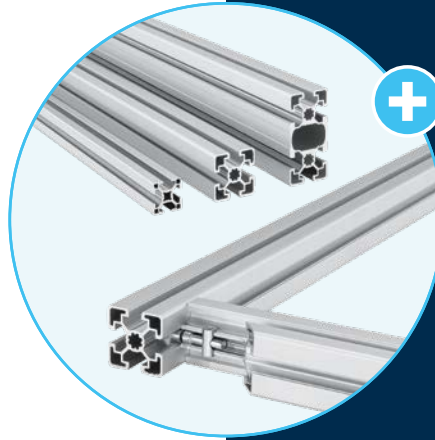

- Largest modular profile system in the world
- Low planning costs
- Short assembly time
- Few tools required
- Flexible expansion and conversion
- Reusable
- Finished surfaces
- Liability safe: compliant with all important certificates



- Wide variety of parts
- Designed for strut profiles
- ESD-compatible components
- Complete linear guides
- LF-MGE Linear Motion Designer planning tool



- Numerous finishing options at virtually every point along the profile
- Easy to configure via eShop and MT*pro*
- Simple logistics and very short delivery times

Aluminum Structural Framing: Safety with the system



UNCOMPROMISINGLY SAFE

Equipment needs to be safe. Accidents can be really expensive for you as the liable manufacturer of equipment or plant operator. The more precisely work environments are tailored to their specific application, the safer they are.

The aluminum structural framing system doesn't just offer quick and highly-flexible solutions for every task, it also offers solutions which conform with legal provisions. So, you're always on the safe side – with all the necessary certificates and supporting documentation – even when it comes to liability.



Safe from the very start!

You can use our planning tool MTpro to lay the foundations for designing and procuring safe equipment. Multilingual and with needs-based functions, e.g. comprehensive calculation programs, you can easily create CE-compliant products in accordance with current standards.



You're in the best hands!

At Rexroth, you can benefit from the expertise of highly technically trained employees and certified processes. Our professionals are happy to assist you in word and deed from your first request through to the completed documentation. Training programs and tried-and-tested product training prepare you in terms of safety.



Rexroth – your system partner!

You can cover yourself against every eventuality with our consistent equipment systems. Consistent use of all the elements in the Rexroth module is the simplest and most efficient way to guarantee the equipment is configured safely. Safety with the system.

Aluminum Structural Framing: Aluminum strut profiles

LIMITLESS FLEXIBILITY

With well over 100 profile cross-sections, we offer the world's largest modular strut profile system for a wide variety of applications. Finely tuned grids, versatile connection elements and accessories let you turn any idea into reality. And another plus: our profiles are all mutually compatible.

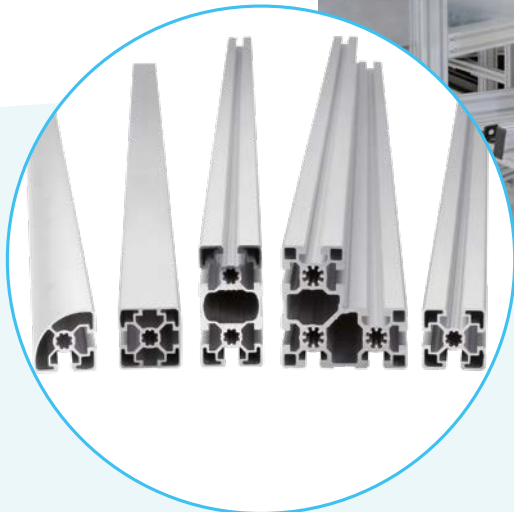

+ Benefits

- Most extensive range of products on the market
- Heavy-duty standard profiles
- Innovative special profiles
- Profiles with closed slots
- Guaranteed performance data, highest stability criteria
- Quick & Easy custom profile finishing
- Available worldwide



Key technical data

- Approx. 140 profile cross-sections
- Ultra-fine profile dimensions (20, 30, 40, 45, 50, 60, 80, 90, 100 mm)
- 3 slot systems: 6, 8 and 10 mm with slot-independent connectors
- Slot pull-out forces up to 24,000 N



Customer applications

- For all industries, especially assembly and handling
- Frame assembly, equipment manufacturing, special-purpose equipment and mechanical engineering

Aluminum Structural Framing: Connection technology

RELIABLE, SECURE AND STABLE

The right connection element for any application – no problem with the modular profile system from Bosch Rexroth. Create reliable solutions with our sophisticated connection technology.



Key technical data

- 28 connector types, 280 variants
- Profile size ranges: 6, 8 and 10 mm with slot-independent connectors
- Slot pull-out forces up to 24,000 N
- Displacement forces up to 15,000 N
- Universal ESD-compatibility
- High-quality appearance with gray or black plastic parts



Customer applications

- Technical and design-oriented solutions
- For all industries, especially assembly and handling
- Frame assembly, equipment manufacturing, special-purpose equipment and mechanical engineering



Benefits

- Heavy-duty connection technology with/without profile finishing
- Innovative product features, such as position detection, centering lugs, extremely scratch-resistant paint, etc.
- Guaranteed performance data
- Available worldwide

Aluminum Structural Framing: *designLINE*

PERFECT COMBINATION OF QUALITY AND FUNCTION

The *designLINE* version of our proven die-cast connectors features an impressive, high-quality appearance that goes perfectly with our strut profiles. Special, aluminum-colored paint enhances the overall appearance of your application, whether that's for a trade fair exhibit or applications in manufacturing, assembly, or other spaces.



Benefits

- Scratch-resistant paint
- ESD-compatibility
- Color matches aluminum profiles
- High-quality appearance



Key technical data

- Same load values as standard connectors



Customer applications

- Frame assembly, enclosures, workstations

Aluminum Structural Framing: Accessories

ADAPTED FOR THE PROFILE SYSTEM AND UNIQUELY VARIABLE

Along with the right profile cross-sections and multi-purpose connection elements, versatile accessories let you turn any idea into reality. A large number of hinges, sliders, clamping elements, feet and rollers, installation and air-supply elements, as well as cover and mounting rim profiles makes countless design options possible.



As the only modular profile system on the market, Rexroth offers the choice between standard accessories in gray and ESD accessories in black. The gray accessories give the frame a high-quality, harmonious appearance through discreet contrast with the profile. The showstopper: Black ESD components make it easy to visually distinguish ESD applications from non-ESD applications.



Benefits

- Large product variety
- Harmonious and high-quality appearance
- Universal ESD compatibility



Key technical data

- Approx. 1,000 accessories
- Designed for 6, 8 and 10 mm slot systems and cross-system compatible
- Application-oriented ESD compatibility



Customer applications

- Frame assembly, enclosures, workstations

Aluminum Structural Framing: Quick & Easy profile finishing

CUSTOMIZED FINISHING

With Quick & Easy, we make it possible to order and receive custom-configured profiles and finishes with a large number of combination options, expanding the proven modular profile system with a multitude of customization options.



Benefits

- Customer-friendly configuration
- Drawing-free ordering
- Attractive finishing prices
- Very short delivery time



Key technical data

- Over 500,000 combination options
- 30 different finishes per profile
- Can be configured via the eShop, MTpro or manually



Customer applications

- Standard finishing for using form-locking connectors
- Basic nomenclature for drawing-free ordering
- Miter cuts

Aluminum Structural Framing: EcoSafe protective fence

MAXIMUM SAFETY AND RAPID SETUP

Stay on the safe side with guard components by Rexroth. EcoSafe protective fence components can be used flexibly and enable compliance with current standards and guidelines. Thanks to its modularity, EcoSafe can be extended with ease and modified at any time with subsequent attachments and alterations.

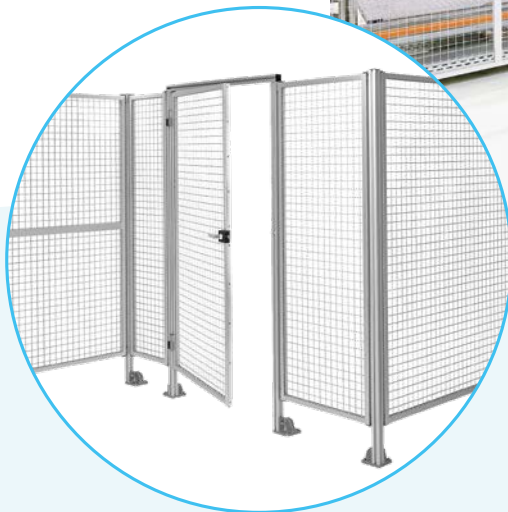

+ Benefits

- Simple planning with standardized kits
- Rapid setup with pre-assembled protective frames
- Flexible, modular design
- Attractive appearance; color versions available
- Compliance with standards:
 - Machinery Directive (2006/42/EC)
 - DIN EN ISO 12100, 13857 and 14120
 - DIN EN 953

✓ Key technical data

- Approx. 50 standard components as well as customizable protective frame versions
- Some kits also support doors
- Woven wire grilles also available in signal colors

↓ Customer applications

- Automotive
- Safety equipment
- Logistics
- Automation

Aluminum Structural Framing: Function-integrated profiles

ALL CABLES INTERNAL – ALL FREEDOMS IN THE DESIGN

Finally, more space for your ideas: The completely internal cable guide allows for all cables to be laid in a safe and space-saving way – and they can even be laid through profile connectors for the first time. This simplifies and speeds up not only the design process, but also assembly and maintenance. With few parts and high variance – and full compatibility with standard profiles.

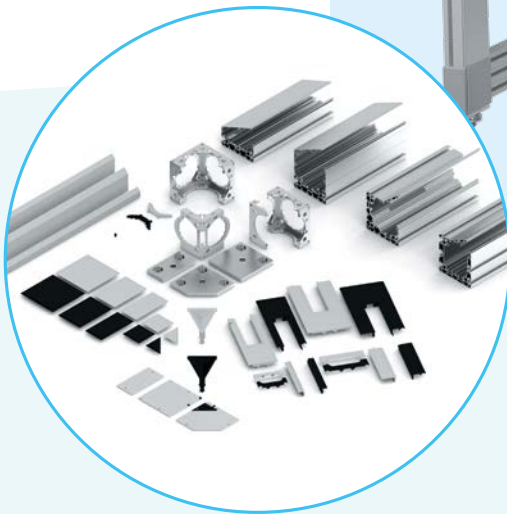

+ Benefits

- Completely integrated wiring in the frame construction
- Unique profile joints with internal cable guide
- High flexibility with low component diversity (only 4 profile cross-sections)
- Exclusive design: sealed outer surfaces, accentuated plastic parts
- Minimal assembly
- Saves time and money: easy design, installation and maintenance



Key technical data

- Grid dimension 40
- Profile slot 10 mm
- Profile cross-section 40 x 120 x 120, 120 x 120, 60 x 120, 120 x 120 6N
- Usable interior space 600 mm² to 4,000 mm²
- Compatible with aluminium modular profile system
- VDE certified
- Suitable for EPA



Customer applications

- For all industries, especially assembly and handling
- Frame assembly, equipment manufacturing, special-purpose equipment and mechanical engineering

Manual Production Systems – ideal conditions for lean production



Just like your individual requirements and productivity goals, efficiency and cost-effectiveness are a top priority for us, and we offer both with our modular assembly solutions. These can be freely configured to suit your needs – flexibly and efficiently.



Manual Production Systems by Rexroth are designed from ground up for use in lean production. With their three pillars – workstations, material supply, and linking, these Manual Production Systems follow a holistic concept that is designed purely for efficiency and the avoidance of waste.

With our Manual Production Systems, you can design ergonomic work-stations or entire production lines that are perfectly suited for your application and for maximum productivity, all with minimum effort. Our intuitive MTpro planning software supports you all the way from planning to the implementation of your custom system.

BENEFITS FOR YOU**Workstation design**

Rexroth gives you flexibility in designing your custom workstation solution. You can choose between custom products by putting together the perfect solution for you from a variety of parameters and standard products with set dimensions. Our overall product range is supplemented by an extensive line of accessories, consisting of workstation lighting, energy supply, on-hand information and tool positioning, ESD components and swivel work chairs.



- Targeted, optimal capacity utilization
- Effortless working
- Increased productivity
- Motivated employees

Material flow and manual linking

Whether it's a flow rack system, material shuttle, FiFo station or manual linking system – with Rexroth components and systems, you can supply materials and containers in a large variety of ways, regardless of which industry, or whether it's for commerce, trades, or industry.

Flow rack systems by Rexroth can be used as central supermarket shelves or directly at a workstation to supply containers, offering you maximum cost-effectiveness and future usability. With an extensive, all-in-one product range for supplying materials for your production and at workstations, you have everything you need. Achieve short material supply routes and readily adapt to changing needs.



- Various conveyor tracks and rollers
- Custom features and dimensions
- Easy conversion and trouble-free expandability
- Efficiency with FiFo method

Information flow

The fusion of production IT and enterprise IT, the synchronization of processes and machines that autonomously make decisions in real time all allow for efficient and customized manufacturing. With Rexroth, you have a production system that places equal importance on ergonomics, lean production and networking.



- More transparency for optimized production
- Digital assembly instructions for variance in manufacturing systems
- Real-time production data processing and visualization

Manual Production Systems: Workstations

ERGONOMICS AND FLEXIBILITY AT THE HIGHEST LEVEL

Ergonomically perfect work conditions are achieved through the use of customized, height-adjustable workstations of variable dimensions and with versatile components for flexible design. Height-adjustable workstations can be adjusted to the height of your employees. Simply switching between standing and sitting avoids repetitive strain and the early onset of fatigue.



+ Benefits

- Large number of adjustment options for high versatility
- Freely selectable geometry and functionality
- Height of material feeds and table tops can be adjusted independently of each other



Key technical data

- Fully assembled or as a kit for self-assembly
- Allows for the addition of any desired modules, including cross ties and conveyor tracks as well as individual components
- Supports up to 400 kg
- Electric height adjustment



Customer applications

- Shift workstations
- Assembly
- Packaging
- Inspection stations

Manual Production Systems: Swivel work chairs

HEALTHY, FUNCTIONAL SITTING

You can easily optimize the ergonomics of your workstations with functional swivel work chairs – specially adapted for each work situation. These chairs effectively cushion the unique physical strain caused by repetitive movements. They provide custom support for each employee to ensure a healthy posture throughout their shift.



+ Benefits

- Dynamic sitting supports employee's movements
- Ergonomic handles for easy adjustment
- Optimal lumbar support



Key technical data

- Tapered backrest
- Ergonomic seat
- Synchronous technology with continuous contact
- Weight adjustment
- 2 height versions: low 460 to 610 mm, high 580 to 820 mm
- Version: fabric, PU, ESD, synthetic leather and cleanroom



Customer applications

- Electronics
- Automotive
- Use in EPAs (Electrostatic Protection Area)
- Optimal ergonomics
- Dynamic sitting

Manual Production Systems: Workstation lighting

THE RIGHT LIGHT FOR TOP WORK QUALITY

Ideal lighting conditions prevent early onset fatigue, improve concentration and reduce the risk of errors. Rexroth's system lamp range provides you with glare-free and flicker-free light of the highest quality. Depending on the task, you can select a single lamp or combine and arrange any number of lamps.



Customer applications

- Assembly and manual workstations
- Inspection workstations
- Packaging workstations

Benefits of LED system lamps

- Glare-free thanks to a parabolic louver and diffuser sheeting
- Up to 60 % energy savings
- 60,000 h service life
- Up to 1,500 lux at a color temperature of 5,000 K

Benefits of LEDeconomic system lamps

- Compact dimensions and low weight
- For workstations with a width of up to 1,600 mm
- High light output of ~140 lm/W
- Up to 700 lux at a color temperature of 5,000 K

Benefits of electronic system lamps

- Up to 25 % energy savings thanks to electronic lamp ballasts
- Quick installation and startup
- Up to 1,500 lux at color temperature of 4,000 K

Manual Production Systems: Drawer cabinet range

VERSATILE AND FUNCTIONAL

Rexroth's range of eight fixed drawer cabinets offers you the highest standard of functionality. A functional system for storing tools and supplies promotes orderliness and cleanliness at the workstation, increasing employee motivation and performance, and eliminating time spent looking for items.

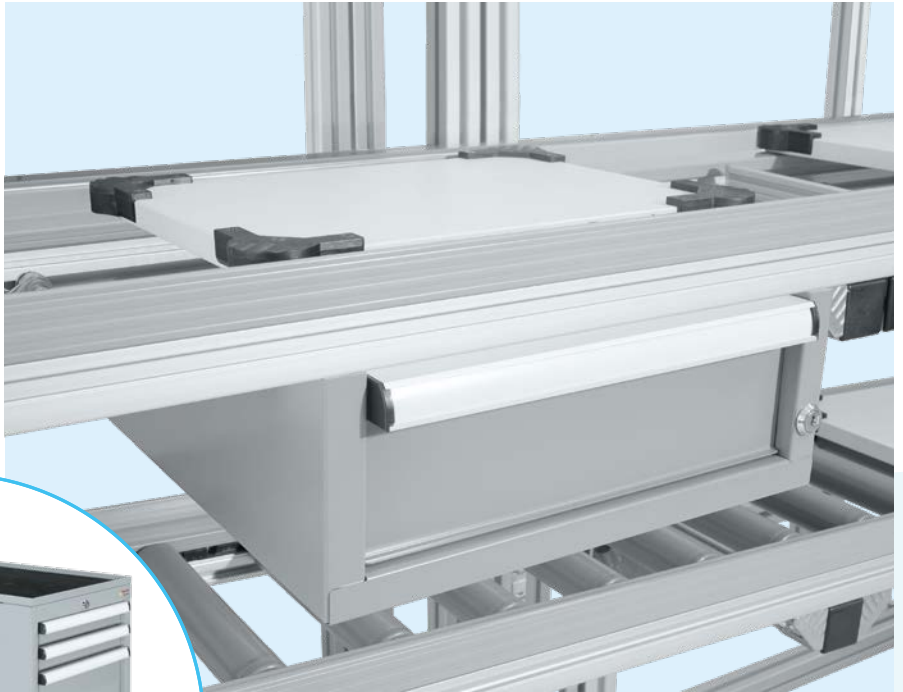

Benefits

- Functional and custom workstation layout
- Defined storage areas, ergonomic aluminum handle bars with label area
- Work processes are supported, transparency increased
- Full-extension, easy-closing drawers



Key technical data

- Soft-closing drawer with ball bearing and automatic closing feature
- Permissible load per drawer: 350 N
- Available in ESD versions
- All drawers can be locked at same time
- Various drawer dividers available as accessories



Customer applications

- Assembly and manual workstations

Manual Production Systems: On-hand information

IMPORTANT INFORMATION ON SITE

Using components for information provision, you provide all important information right at the workstation and in production. Your employees can then make the right decisions and take immediate action. Information provision guarantees high transparency and is essential for certification according to DIN ISO 9000 ff.



+ Benefits

- High transparency
- Increased efficiency through clear structure
- High stability

✓ Key technical data

- Can be mounted horizontally or vertically
- ESD version
- A4/US format, 2x A4
- Up to 18 reinforced transparent plastic sleeves

↓ Customer applications

- Assembly and manual workstations
- Safety instructions on machines

Manual Production Systems: Tool storage

REDUCED ASSEMBLY TIMES DUE TO TOOLS BEING CLOSER TO EMPLOYEES

The ergonomic storage of tools and parts forms the basis for efficient workstation design. Easy access to tools avoids repetitive, burdensome and unnecessary movements.

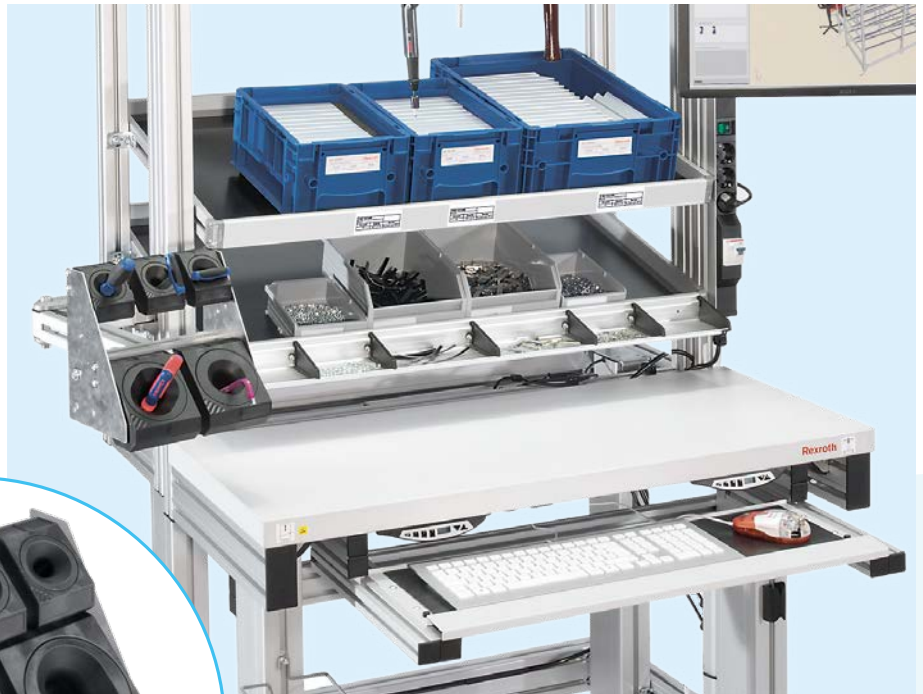

+ Benefits

- Space-saving and ergonomic storage
- Faster assembly time
- Modular design
- Standard parts for individual solutions

✓ Key technical data

- ESD version
- MTM-optimized
- Fastening kit included

↓ Customer applications

- Assembly and manual workstations

Manual Production Systems: Electric case lifter

RELIEF IN LIFTING AND LOWERING LOADS

Case lifters are used for ergonomic parts supply at workstations. To keep the physical strain on your employees as low as possible, the case lifter lifts and lowers loads, preventing improper working posture and excessive strain. Your employees can then concentrate on value-creating activities.



+ Benefits

- Ergonomic parts supply
- Reduced parts supply and removal times
- Automatic stacking/unstacking

✓ Key technical data

- Lift: 900/1,300 mm
- Lifting speed: 25 mm/s
- Permissible load F_{\max} : 2,200 N
- ESD version

↓ Customer applications

- Assembly and manual workstations

Manual Production Systems: Lean/Xlean flow rack systems

REDUCED STOCKS THROUGH EFFICIENT MATERIAL SUPPLY

Well-structured and clearly organized material supply promotes transparency and helps you reduce your stocks. Rexroth's flow rack systems offer users in commerce, trades and industry a wide range of important benefits.



Benefits

- Stock reduction
- Reduction in setup times
- Easy conversion and attachment, expansion
- Stock visualization (Kanban color signal)
- Materials used in specified order (FiFo method)



Key technical data

- ESD version
- Rapid planning with MTpro



Customer applications

- Assembly and manual workstations
- Supermarkets
- Logistics

Manual Production Systems: FiFo station and material shuttles

INTEGRATED KANBAN SUPPLY SYSTEM

Standardized material supply in production using defined delivery areas creates clarity and a high degree of transparency. Complying with the FiFo principle facilitates simple traceability in the case of material faults or disruptions in the process. The FiFo station can be compared to a supermarket for floor rollers, material shuttles and commissioning shuttles.



+ Benefits

- Clearly organized and transparent production operations through standardized delivery areas
- Clear visualization to help minimize stocks
- Modular rail system design
- 5S support for material supply

✓ Key technical data

- Plastic guides
- Inclusion of flow rack systems, information boards and height limits by integrating 30 x 30 profiles
- Guide rails glued/screwed onto floor

↓ Customer applications

- FiFo station
- Logistics station
- Stock visualization

Manual Production Systems: EcoFlow

MANUAL LINKING ELEMENTS BRINGS EVERYTHING CLOSER

Manually linking workstations with EcoFlow eases employee strain because products and workpiece pallets are conveyed on manual slide sections. At the same time, investment in this linking remains low since the EcoFlow conveyor tracks work without any electric drive systems or controllers.



+ Benefits

- Economic linking of different work steps
- Employee relief: no carrying heavy loads
- Pre-assembled conveyor tracks available
- Can be combined with Rexroth's power-driven transfer systems

✓ Key technical data

- ESD version
- Aluminum profile conveyor track
- Full-width rollers available in plastic, steel or stainless steel
- High design flexibility

↓ Customer applications

- FiFo transport of parts up to 10 kg

Manual Production Systems: EcoShape tubular framing system

VERSATILE, SIMPLE, EFFICIENT

With EcoShape, build custom solutions from just a few components. Not only is planning easy thanks to the MTpro planning software, assembly is also a breeze since the standard components feature a poka-yoke design for rapid, trouble-free building.



Benefits

- High stability with sophisticated connection technology
- Extend existing production lines with ease
- Just cut to size, assemble and handle
- Combine with modular aluminum framing system for heavier loads
- On-site configuration and assembly



Key technical data

- ESD version
- Die-cast zinc



Customer applications

- Workstations
- Material shuttles
- Flow and transport racks
- Assembly islands
- Design solutions

Manual Production Systems: Grab containers, grab ledges

EFFICIENT AND EASY GRAB- BING OF SMALL PARTS

Rexroth's ergonomically shaped grab containers customize your workstations and assembly areas, eliminating unnecessary and unproductive movements through shorter grab distances. This saves you valuable production time while also minimizing strain on your employees.



+ Benefits

- Ergonomic, handy supply of small parts such as screws, nuts and washers
- Ergonomically designed removal areas
- Grab things quickly and safely
- Combined system (grab containers, grab ledges, covers)

✓ Key technical data

- Stable, compact stacking connections
- Variety of sizes, flexible design
- Available in ESD versions
- MTM-optimized

↓ Customer applications

- Assembly and manual workstations

Material and information flow technology – sturdy, economical and universally modular



Cost-effectiveness in investment and operation, reliability, and adaptability are the essential criteria. Experience and expertise from countless projects with wide variety of requirements make Rexroth your partner of choice.

The demands are challenging: high quantities with short cycle times through full automation or small batch sizes with a large range of variation in partially automated systems with manual workstations. With its proven transfer and chain conveyor systems, Rexroth offers economical material flow solutions that can be scaled as needed for almost any application.

Benefits for you: All systems are designed for modular flexibility. This speeds up planning – and allows you to easily upgrade or modify existing systems. Sturdy products and innovative technology ensure high reliability at low maintenance costs.

BENEFITS FOR YOU**Transfer systems**

Whether transporting small, sensitive products weighing just a few grams or large products weighing several hundred kilos, whether in a cleanroom or an oily environment, the TS 1 to TS 5 transfer systems by Rexroth are proven in numerous sectors and are always the right choice.



- For workpiece weights of a few grams up to 400 kg
- High throughput due to short cycle times
- Versatile combination options with individual modular components

Chain conveyor systems

Rexroth chain conveyor systems meet hygiene requirements in the food and packaging industry, transport even small parts directly on the virtually sealed chain surface and deal with inclines and declines with ease – critical aspects for linking machines in numerous sectors of industry.

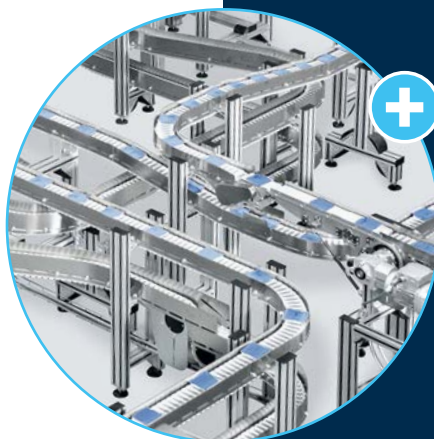

- Modular design for the simple implementation of custom routing
- High chain tensile forces up to 1,250 N minimize the number of drives
- 6 standard widths – the right size for any product

RFID systems

Identification and data carrier systems ensure the flow of information with goods on the assembly lines. Object-related data enables the targeted control of process and processing steps, as well as the type-dependent or version-dependent, inbound and outbound transfer of workpiece pallets during the production of product variants on branched, flexible assembly systems. Documenting all process steps and production data enables traceability even when errors occur.

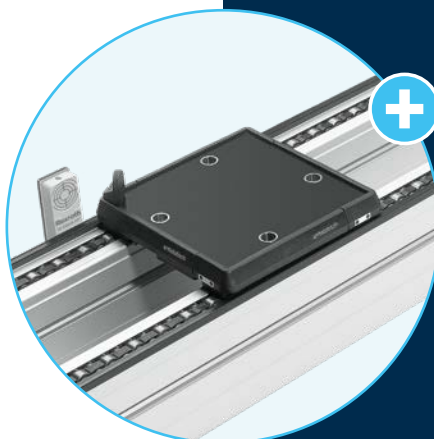

- Quick and easy workpiece identification
- Suitable solutions for all Rexroth transfer systems
- Flexibility through extensive variety of attachments and assembly kits

Material and information flow technology: ACTIVE Mover transfer system

THE STANDARD IN SHORT CYCLE - MORE PRECISE, FASTER, MORE HEAVY-DUTY

Wherever products need to be transported and positioned with extra precision, speed and flexibility, the Rexroth transfer system sets the standard: With a unique combination of precision, speed, power and flexibility, you can increase process quality, productivity and even cost-effectiveness.



+ **Benefits**

- No additional indexing needed
- Broad spectrum of uses
- Low-vibration transport of sensitive products
- Freely programmable and easily changeable workpiece pallets
- Connect any controller
- Low-wear



Special components

- AMpro software: system configuration and programming-free startup
- Identification system: unique workpiece pallet identification



Key technical data

- High repeat accuracy of ± 0.01 mm
- Speed of up to 150 m/min
- Acceleration of 40 m/s^2 with 1 kg load, 10 m/s^2 with 10 kg payload
- Load per workpiece pallet of up to 10 kg
- Workpiece pallet width of 165 mm, up to 500 mm for intake
- Sturdy design
- Reversible operation
- Asynchronous and synchronous operation
- Open interface: Ethernet/IP, PROFINET, EtherCAT, Sercos, etc.



 **Customer applications**

Assembly lines in key sectors:

- Electronic controller parts
- Printed circuit boards for electronics manufacturing
- Pharmaceutical and cosmetic industries
- Syringes in the medical technology sector
- Components for electric motor production

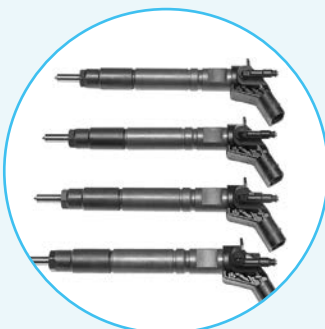

Material and information flow technology: TS 1 transfer system

PRECISE ASSEMBLY AND RAPID PROCESSES

When it comes to the efficient production of small products or modules, the Rexroth TS 1 transfer system is the right decision. It is specially tailored to the precise assembly of complex products. The ability to integrate into the pre-assembly and subassembly of a higher-level system is one of its strengths.

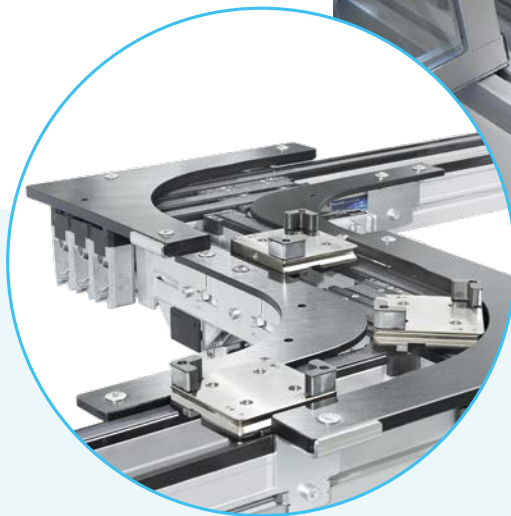
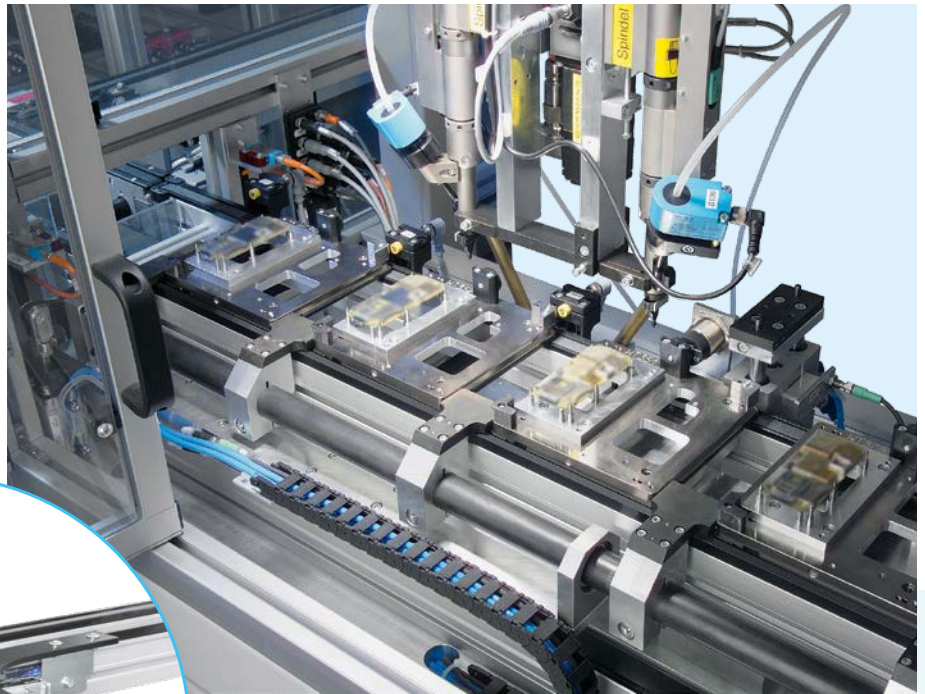

+ Benefits

- Compact design requires less space
- Suitable for EPAs, cleanrooms and dry rooms
- MTpro planning tool with Layout Designer and automatic parts list generation

! Special components

- Accumulation curves for short throughput times
- Positioning unit for top repeat accuracy and quick workpiece pallet changeover

✓ Key technical data

- Workpiece pallet weight up to 3 kg
- Workpiece pallet sizes 80 x 80 mm, 120 x 120 mm, 160 x 160 mm
- Workpiece pallet varieties: plastic, plastic/steel and aluminum
- Conveyor media: belt, toothed belt
- Conveyor speed: 6, 9, 12, 15, 18 m/min
- High repeat accuracy of ± 0.015 mm
- Suitable for Class 6 cleanrooms (EN ISO 14644-1)
- Suitable for dry rooms (up to approx. 1 % relative humidity)

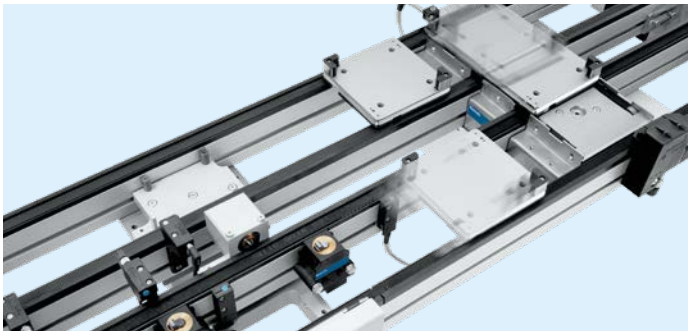

Customer applications

Assembly lines in key sectors:

- Automotive
- ESD-sensitive electronics
- Medical technology
- Optics industry
- Automotive battery production
- Components for electric motor production



Material and information flow technology: TS 2plus transfer system

ALL-ROUND TALENT FOR A BROAD SPECTRUM OF USES

The TS 2plus is an all-round talent for economical assembly systems that has proven itself for decades in thousands of applications. Workpiece pallets from 160 x 160 mm to 1,200 x 1,200 mm and several combinable conveyor media form a flexible, modular system that allows you to easily implement a wide range of system layouts.

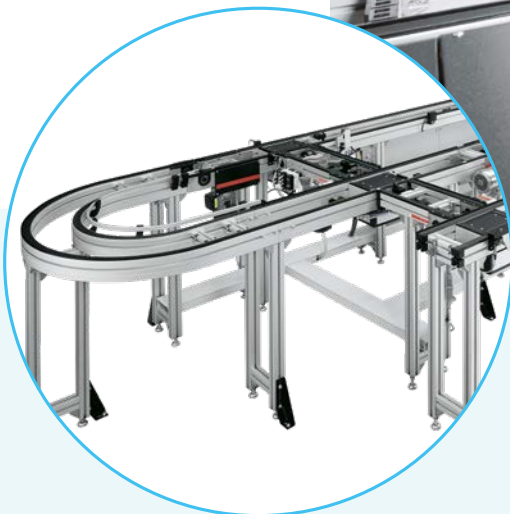

+ Benefits

- Highly cost-effective due to perfected components that have been proven for years
- Can be perfectly adapted to customer requirements thanks to the largest product range on the market and various conveyor media
- Suitable for EPAs, cleanrooms and dry rooms
- Low operating costs thanks to low maintenance costs and coordinated material combinations
- High availability due to consistent monitoring
- MTpro planning tool with Layout Designer and automatic parts list generation



! Special components

- Six (6) different conveyor media
- Wide range of transverse lifting units, positioning units and transportation control components
- Very extensive range of modifications



✓ Key technical data

- Workpiece pallet weight: max. 240 kg
- Pallet sizes: 160 x 160 to 1,200 x 1,200 mm
- Pallet types: steel or aluminum carrying plates; open frame made of aluminum profiles available
- Conveyor media: toothed belt, belt, flat top chain, accumulation roller chain, Vplus chain, duplex chain
- Conveyor speed: 6, 9, 12, 15, 18 m/min
- Section load: max. cumulative load of 200 kg/m
- Suitable for Class 7 cleanrooms (EN ISO 14644-1)
- Suitable for dry rooms (up to approximately 1 % relative humidity)



Customer applications

Assembly lines in key sectors:

- Automotive
- Electric motor production
- Automotive battery production
- Electrical devices
- Electronics (EPA-compatible)
- Medical technology and public health



Material and information flow technology: TS 2plus booster

TEN TIMES QUICKER IN SHORT CYCLE TRANSFERS

The innovative workpiece pallet booster reduces cycle times to a minimum. That means unproductive times before and between individual stations are significantly reduced: Depending on the application, the booster is up to ten times quicker than standard transfers, with accelerations of up to 3 g. Highly precise and without any indexing.

As a modular application in the Rexroth TS 2plus transfer system, it gives your processes a boost in no time.

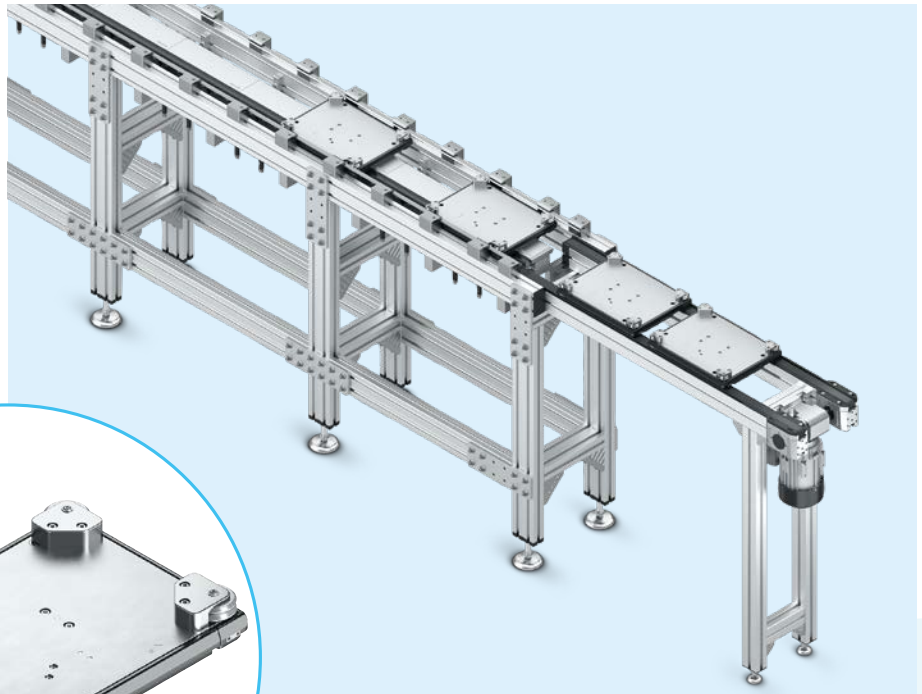

+ Benefits

- Quick: gain in productivity thanks to short pallet changeover times
- Precise: exact workpiece pallet positioning without additional indexing
- Flexible: individual startup in various positions – independently of pallets
- Gentle: stopping delicate products without any impacts
- Compatible: save on assembly time and assembly costs due to standardized and pre-configured modules and the use of the standard pallet WT 2
- Modular: flexible section within the TS 2plus transfer system



Key technical data

- Acceleration max. 3 g/30 m/s²
- Speed max. 3 m/s (180 m/min)
- Workpiece pallet lengths from 160 mm up to 640 mm
- Workpiece pallet widths from 160 mm up to 400 mm
- Workpiece pallet changeover time 0.5 s for workpiece pallet lengths of 160 mm
- Loads up to 40 kg/pallet
- Positioning accuracy up to ±10 µm



Customer applications

- Electrical equipment and electronics
- Automotive
- Medical technology
- Healthcare

TS 2plus booster components

A complete series of pallet based transfer, positioning, and control modules satisfies all requirements of manual and automated assembly operations, and allows the configuration flexibility required in today's competitive manufacturing environment.

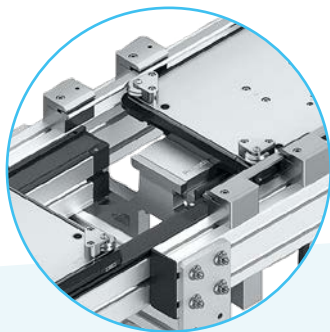

GUIDE RAIL

The low-wear roller guide rail enables precise and zero-clearance positioning of the workpiece pallet on the linear section (LS 2)

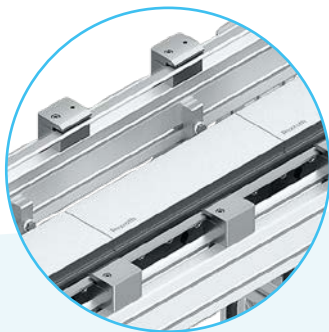

MOTOR

Stationary electromagnet – contrary to the circular arrangement in the rotary motor, the electromagnets are placed next to each other in the linear motor

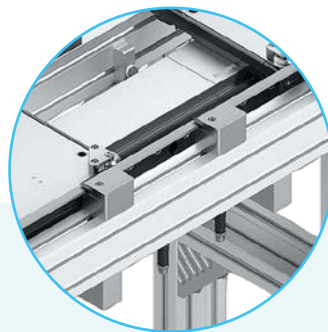

SENSOR SYSTEM

Contactless, dirt-resistant absolute measuring system for detecting WT positions on the linear section using measuring magnets (Hall sensor system)

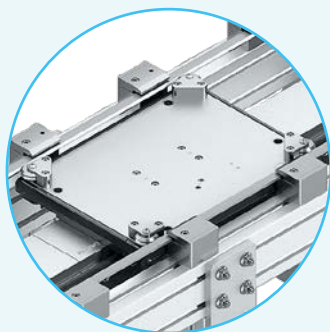

WORKPIECE PALLET

Permanent magnets mounted on the bottom of the WT 2/LS ensure the required feed according to the "moving magnet motor" principle

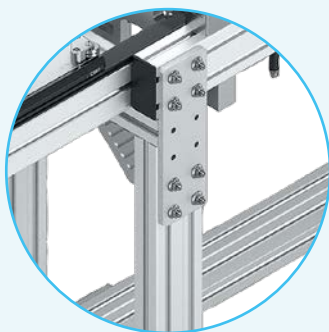

LEG SET

The section supports are suitable for accommodating heavy-duty, single-track LS 2 linear sections

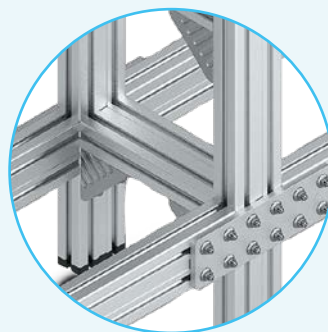

LONGITUDINAL/CROSS CONNECTORS

To compensate for the higher dynamics of the system, e.g. by fast stop or acceleration, all construction elements are designed accordingly stable

Material and information flow technology: TS 5 transfer system

MODULAR AND LOW- MAINTENANCE FOR LOADS OVER 400 KG

The heavyweight in the Rexroth product line shines thanks to its tremendous cost-effectiveness and consistent quality. With its king shaft drive, the TS 5 stands out as a rugged pacemaker even in the harshest manufacturing environments – and the greatest possible degrees of freedom for you when it comes to layout planning and use of space. The TS 5 is also ideal for ESD environments, clean rooms and dry rooms.

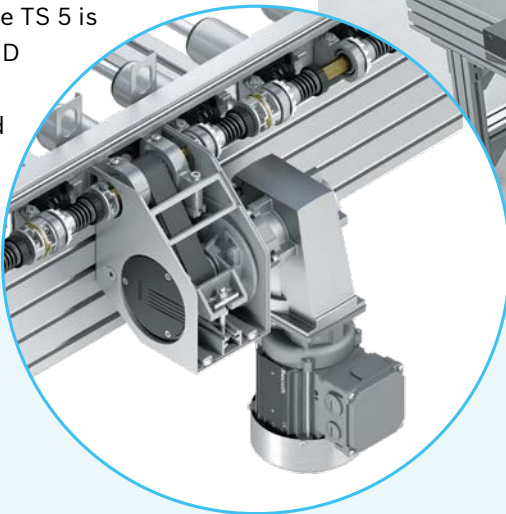
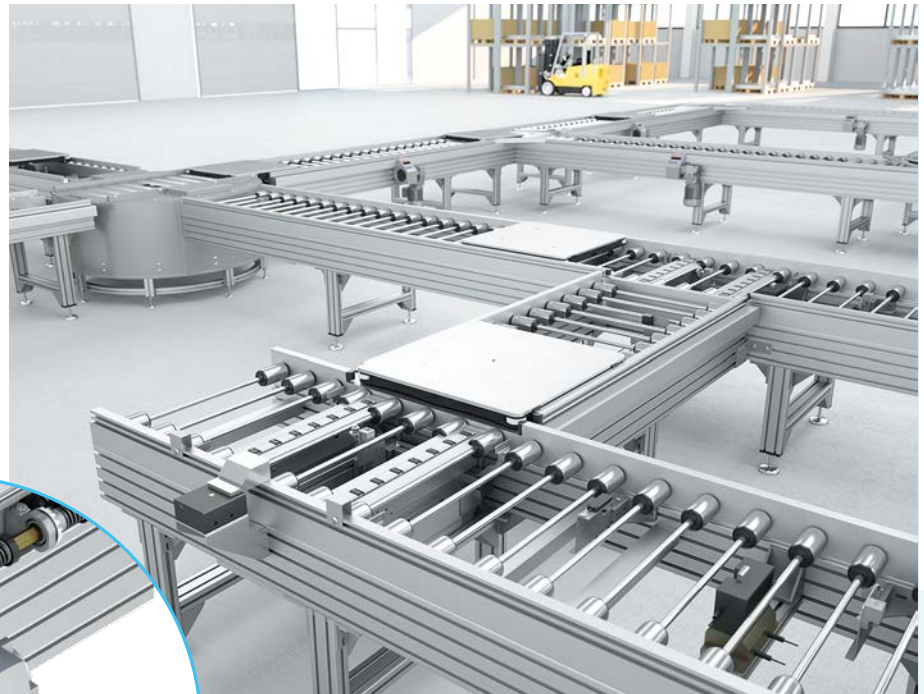

+ Benefits

- Modular: modular system with a wide range of applications
- Reliable: drive concept with minimal maintenance and long service life
- Efficient: easy and fast planning, components with top quality and energy efficiency
- Suitable for EPAs, cleanrooms and dry rooms
- MTpro planning tool with Layout Designer and automatic parts list generation



Special components

- Low-maintenance, energy-efficient drive concept with king shaft
- “Open Center” open conveyor section for easy access to the workpiece from below



Key technical data

- Workpiece pallet weight: max. 50 kg per roller
- Workpiece pallet sizes: 455 mm to 1,040 mm (standard widths)
- Roller diameter: 60 mm
- Roller spacing: 130, 195, 260, 325 mm
- Conveyor speed: 2–18 m/min
- Approved for Class 8 cleanrooms in accordance with DIN EN ISO 14644-1



Customer applications

- Front-end semiconductor industry
- Solar
- Battery production
- Display production
- Assembly and handling
- Computer, communication, consumer electronics

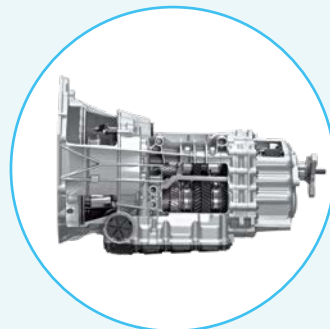

Material and information flow technology: TS 2pv transfer system

GENTLE, CLEAN, ECONOMICAL – IDEAL FOR MODULES

Solar module manufacturing is an extremely sensitive, complex process that is highly demanding on material transport as the glass panels are large, fragile and extremely sensitive to contamination. The TS 2pv meets these strict requirements while also being highly economical.



+ Benefits

- Shock and vibration-free transport
- Gentle module transfer from longitudinal to transverse sections
- Soft braking and accelerating
- Suitable for EPAs, cleanrooms and dry rooms
- Low operating costs thanks to low maintenance costs and coordinated material combinations
- High availability due to consistent monitoring
- MTpro planning tool with Layout Designer and automatic parts list generation



Special components

- All components for sensitive transport of glass panels and modules
- Components for high-friction transport without guide rails
- Transverse lifting unit
- Application-specific toothed belts for various environmental conditions



Key technical data

- Panel weight up to 120 kg
- Panels up to 2,200 mm in length along the edge
- For transporting hot glass modules up to 150 °C
- Completely silicon-free, no exposed grease or oils
- Available in 2, 3, 4 and 5-track versions
- Suitable for Class 7 cleanrooms (EN ISO 14644-1)
- Suitable for dry rooms (up to approx. 1 % relative humidity)



Customer applications

Module production

- Crystalline solar modules
- Thin-film solar modules

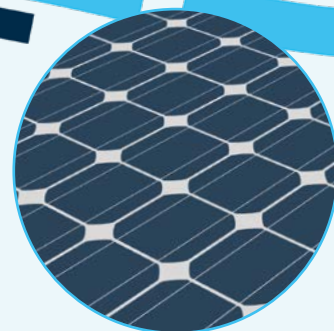
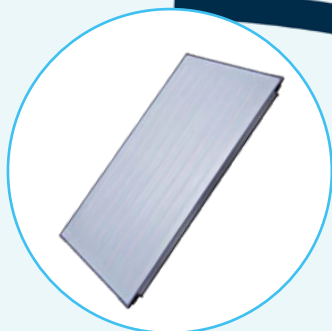
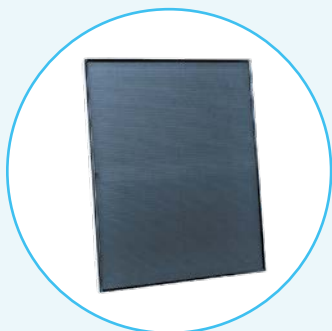

Material and information flow technology: VarioFlow *plus* chain conveyor system

FLEXIBLE TRANSPORT SYSTEM FOR EFFICIENT OPERATION

Today, user requirements for transport solutions are more demanding than ever. With VarioFlow *plus*, Rexroth offers a powerful and versatile conveyor system. Create your custom conveyor solution from our extensive modular system. Even in close quarters and in the most demanding spatial conditions, VarioFlow *plus* can meet any challenge.



+ Benefits

- Simple assembly: fast, fail-safe setup due to smart connection technology and lateral slide rail mounting
- Quiet operation: optimized sliding properties only require a few drives and guarantee energy efficient operation
- High flexibility and planning freedom: sophisticated drive power allows for a large degree of planning freedom



Special components

- Patented chain design for reduced noise
- Unfinished sliding surfaces through lateral mounting
- Bilateral motor interface in drive and return unit
- Optional workpiece pallet system



Key technical data

- Chain tensile force: max. 1,250 N (ESD 600 N)
- Conveyance speed: max. 60 m/min (100 m/min on request)
- Chain width: 65, 90, 120, 160, 240, 320 mm
- Noise level during operation: typically < 70 dbA at 30 m/min
- Versions: aluminum or stainless-steel design



Customer applications

Conveyor system for horizontal and vertical transport in key sectors:

- Food, packaging
- Pharmaceutical and cosmetic industries
- ESD-sensitive electronics
- Automotive
- Interlinking machines



Material and information flow technology: RFID identification systems

SECURE AND RELIABLE DATA COMMUNICATION

RFID systems are cost-effective, reliable solutions for implementing the flow of information with goods in assembly systems. Product and order-related data can be saved directly in the data carrier (data-on-chip) or in a central database (data-on-network).



All Rexroth RFID systems are write/read systems and support common field buses. They are perfectly matched to the transfer system and VarioFlow. ID 200 is the ideal system for Ethernet-based communication using standardized ISO 15693 data carriers. With its compact size, ID 15 is perfect for small systems and central data storage.

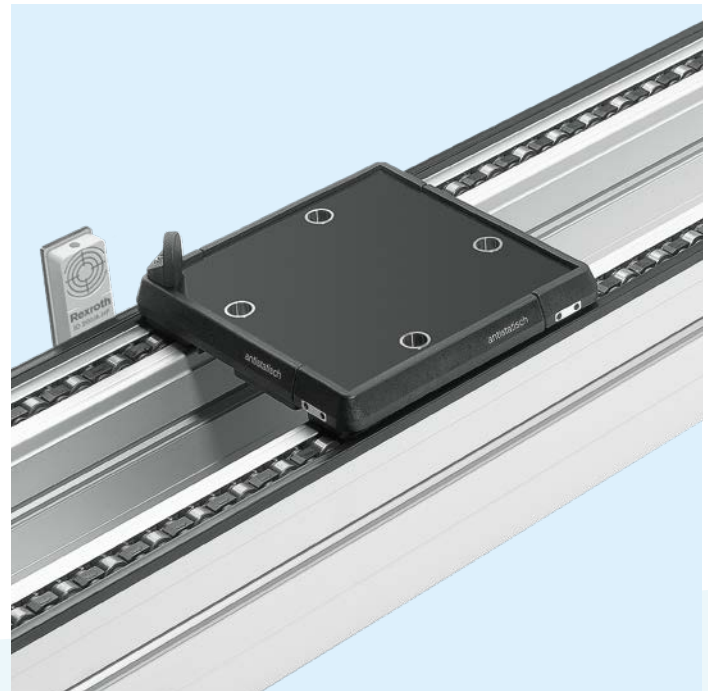

ID 200 – Technical data

- Interfaces PROFIBUS DPV0, RS232, PROFINET, Ethernet/IP, TCP/IP, Modbus/TCP
- Transmission frequency 125 kHz (LF), 13.56 MHz (HF, ISO 15693)
- Transmission distance Max. 35 mm (HF) Max. 15 mm (LF)
- Storage capacity 2 kB FRAM, 5 bytes EEPROM Data carrier

**ID 15 – Technical data**

- Interfaces ASI
 - Transmission frequency 125 kHz
 - Transmission distance Max. 20 mm
 - Storage capacity 15 bits EEPROM
- Data carrier

Conveyor Service: Certified quality with you every step of the way



Count on our expert field technicians to keep the Rexroth conveyors, AMRs, and tightening tools in your factory automation systems running with peak efficiency and accuracy. Only Bosch Rexroth has the factory-authorized repair systems and factory-trained service personnel to ensure that all your assemblies are built and maintained to their original performance specification.

Conveyor Service: Explore More Service – Field service for ACTIVE Mover

OUR SERVICE – YOUR BENEFITS

Get your ACTIVE Mover system up and running quickly and correctly with Rexroth’s expert field service. Once it’s up, our team can also assist with preventative maintenance and field service support to help avoid cost machine downtime.



+ We get you started

Rexroth field service can help you get your machines up and running quickly and correctly from the very beginning. Initial training helps your team to operate and maintain equipment as new.

- Complete on-site assembly or installation supervision
- Recommended spare parts
- Installation and maintenance training

+ We keep you moving

With your equipment up and running, Rexroth experts assist you with preventative maintenance and field service support to keep your machines running.

- Preventative maintenance
- Field service and repair
- Technical consultation and spare parts support

+ We keep you efficient

Rexroth field service technicians are here to keep your machine running optimally with modifications and optimizations to suit your needs.

This includes:

- Pallet inspection, wheel replacement, static brush and felt pad replacement
- Pallet testing, calibration
- Pallet tuning
- Program optimization
- Training on program optimization, tuning and maintenance

Conveyor Service: Explore More Service – Field service for TS Conveyors and VarioFlow plus

KEEP PRODUCTION MOVING WITH TS CONVEYORS AND VARIOFLOW PLUS MAINTENANCE & TUNE-UP SERVICE

Our highly-trained field service technicians are here to help with on-site assembly and installation of TS conveyors and VarioFlow plus systems – so your team can focus on what's important. Or, ask one of expert technicians to support your local team with installation. After installation, keep your conveyors running smoothly with maintenance contracts, spare part recommendations, and tune-up services.

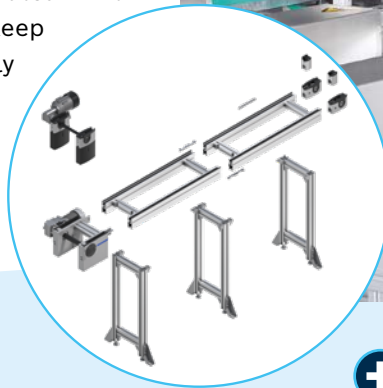

+ We get you started

Rexroth field service can help you get your machines up and running quickly and correctly from the very beginning. Initial training helps your team to operate and maintain equipment as new.

- **Complete on-site assembly or installation supervision**
 - The quickest way to get set up is with our experts on-site
 - Installation support tailored to your needs and team available
- Recommended spare parts
 - With over 40 years of experience, our experts know which spare parts you'll need on hand to keep you running
- **Installation and maintenance training**

+ We keep you moving

With your equipment up and running, Rexroth experts assist you with preventative maintenance and field service support to keep your machines running.

- **Preventative maintenance**
 - Avoid costly machine downtime
 - **We inspect your system on a regular basis and identify necessary adjustments to prevent the hassle of an emergency fix**
- Replacement of belts, chains, guides and bearings
 - Is your chain worn out, your belt lurching, or has your system become noisy? We replace your worn-out parts on-site and ensure a smooth start-up
- **Field service and repair**
 - Whatever happened, we will fix it! But we recommend preventative maintenance to avoid costly downtimes
- Technical consultation and spare parts support

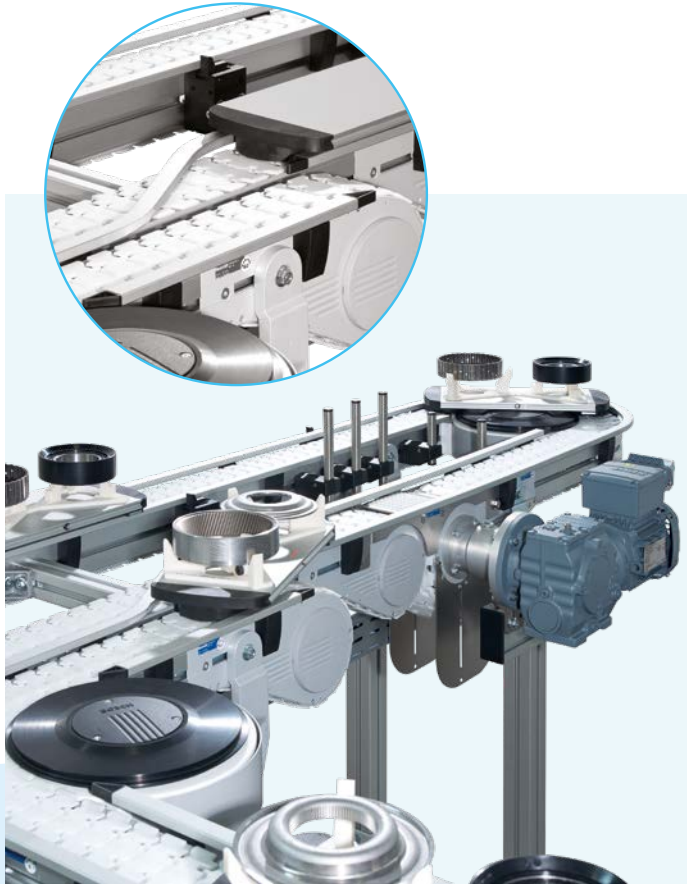

+ We keep you efficient

Rexroth field service technicians are here to keep your machine running optimally with tune-ups and modifications to suit your needs.

- **Conveyor module alignment and adjustment**
- **Conveyor “Tune-Up” evaluation & service**
 - After running your conveyor for multiple years, keep going with a tune-up!
 - Conveyor tune-ups can include replacement of belts, chains, guides, and bearings (wear parts) as well as gearboxes, motors, lift and transfer units
 - Benefit from higher productivity, energy efficiency, and lower noise level
 - Ensures reliability when running more shifts or higher volume products
- **Upgrade your transfer media**
 - Changing from belt to flat top or to roller chain enable you to run heavier products or run your products faster

BENEFITS OF SERVICE

- + Inspect workpiece pallets, including wear pads and end pieces for wear patterns and make recommendations based on inspection**
 - Inspect bushings and other hardware on pallets for missing or damaged parts
 - Remove covers from power drives and idle units to check for any foreign materials or debris; then clean dirt/debris out of housings
 - Inspect and adjust main conveyor runs for proper alignment and leveling
 - Inspect main conveyor flat belts, belt guides, chains, and chain guides for condition and/or wear
 - Lubricate, as needed
 - Clean and Inspect all motors and gear reducers for excessive noise, vibrations, high amperage or leakage
 - Inspect profile rail connectors, leg sets and foundation for brackets missing hardware, or loose and missing bolts, and tighten or replace as applicable
 - Inspect pallet trafficking controls, prox holders and accumulation controls for proper operation and broken/worn parts

- + Additional items for TS conveyors:**
 - Review and inspect lift transfer modules for proper belt tensioning and alignment. Make any alignment or adjustments to ensure optimal performance
 - Inspect transverse conveyor toothed belts (or chain) for excessive wear
 - Inspect vertical pallet transfer units for proper alignment and adjust as application requires
 - Review and inspect cross transfer conveyor modules for proper belt tensioning and alignment of the drive unit for tandem units and adjust drive belts, or synchronization belts, if needed

- Upgrade to latest innovations and state-of-the-art technology
- Modifications and replacements
 - **Looking to use your existing line for a new product?**
We can help you adapt it to your new needs
- **Spare part inventory evaluation**
 - We have a look into your inventory parts and levels
 - You can focus on running your production!

Intralogistics: ACTIVE Shuttle – the autonomous transport system for future intralogistics systems

WITH PLUG & GO START QUICKLY AND MOVE SAFELY

The autonomous transport system ACTIVE Shuttle is already making entry into the factory of the future: it is implemented quickly without adapting your existing factory infrastructure, intuitive to operate, completely connected and safe for people to use!



ACTIVE Shuttle

The ACTIVE Shuttle autonomous transport system is already making the transition to the factory of the future possible today: It is quick to implement without any need to adapt your existing factory infrastructure, intuitive and easy to operate, fully connected and safe for use around people! Create transparent and efficient internal processes using ACTIVE Shuttle.

ACTIVE Shuttle Management System (AMS)

AMS-Live Map

The ACTIVE Shuttle fleet immediately records occurring changes in the production environment and automatically updates the reference map. Therefore, manual re-mapping belongs to the past.

Quick and flexible adaptation

Short-term changes can be made during live operation with a few clicks in the AMS.

Traffic management

If a number of ACTIVE Shuttles are in use, they communicate with each other wirelessly via the AMS and inform each other about changes in the environment in order to be able to react prematurely to bottlenecks.



AMS functions

- Order management: Prioritizing and distributing transport jobs to available

ACTIVE Shuttles

- Job templates: Easy configuration of your transport concepts
- Traffic management: Transport control center ensures coordinated and smooth transport operation
- Obstacle management: Navigate safely around obstacles
- AMS Live Map: Changes in the factory environment are automatically detected by the operating vehicles and communicated to the entire

ACTIVE Shuttle fleet

- Energy management: Fully automated charging process
- Web application: Intuitive and user-friendly user interface



Key AGV technical data

- Load dimensions (L x W x H): 600 x 400 x 1200 mm
- Navigation technology: Laser navigation
- ACTIVE Shuttle dimensions:
(L x W x H): 1,015 x 405 x 900 mm
- Transport weight: Max 260 kg
- Drive speed: Max 1 m/s
- Mobile gradients: Yes
- Laser type: Safety laser scanner, type 3, SIL2, performance level d
- 3D obstacle detection: 2 stereo cameras
- Touchscreen display: 10.1 inch, 1,280 x 800 pixels
- WLAN: IEEE 802.11.ac/a/b/g/n
- ESD (electrostatic discharge)
- Conformity: CE

BENEFITS FOR YOU



Plug & Go – quick and easy to implement without adapting the existing factory infrastructure



Automated materials transport with fully automated loading and unloading



Easy, intuitive operation of the entire system



Navigate safely around obstacles



Easily create and configure logistics scenarios using AMS



Return on Investment (ROI) within two years



Comprehensive safety concept, designed for continuous 24/7 mixed operation with people and machines



Employee relief



Standard interface for connecting to third-party systems



Increase in transparency



Reduction of surfaces and materials

Intralogistics: Rexroth ROKIT Locator – Your easy-to-use laser localization software



This is made possible by a high-performance algorithm that automatically detects and maps the natural environment using a laser sensor on the vehicle. Bosch Rexroth thus provides a key technology and resolves the challenge of localizing your mobile robots with maximum flexibility and usability.

Flexibility for all situations

Benefit from the effortless integration of the ROKIT Locator into a wide range of vehicle types as well as into numerous industries and application areas. Thanks to the modular approach, the localization software is hardware-independent.

Outstanding usability

Due to the fast and easy setup and reliable operation of the localization and mapping software, you do not have to worry about locating your mobile robots. The flexible adaptation to changing environments also enables automatic map updates for your entire fleet.

**ROKIT Locator Features**

- **Express mapping** – guided live mapping Maps the environment with just a few clicks without the need for infrastructure adaptations or expert knowledge.
- **Masking** – Hides vehicle contours in sensor data.
- **Manual map alignment** – Adjust the map with offsets and rotations.
- **Reference alignment** – Align the ROKIT Locator map to an existing coordinate system.
- **Initial localization** – Automatic localization after a change of position.
- **Robust and reliable localization** – Functions smoothly in dynamic industrial environments regardless of vibrations and ramps.
- **Wheel odometry fusion** – The positioning includes information of laser scans and estimated movements of the vehicle based on the wheel rotations.
- **Map update** – Automatically detects changes in the environment, continuously updates the ROKIT Locator map, and shares it with the entire ROKIT Locator fleet.
- **Map expansion** – Allows users to extend existing ROKIT Locator maps and replace map zones.
- **Dual laser** – Supports up to two lasers.

BENEFITS FOR YOU

-  Suitable for a wide range of vehicle types, industries and application areas
-  Available as software-only solution or as Rexroth ROKIT Locator Box – ready to use on an extremely compact industrial computer
-  Supports numerous brands and types of laser scanners and industrial computers
-  Flexible laser positioning
-  Express mapping
-  No need for infrastructure adaptations or expert knowledge
-  No maintenance of infrastructure required
-  Live mapping software: automatic map updates

MTpro planning software – optimal layouts for assembly systems



MTpro is an intuitive piece of software used for planning assembly systems. It assists you from selection and configuration through to ordering components.

With MTpro, you can plan, calculate and document your assembly systems in just a few steps. Whether it's a transfer system, profile frame or Manual Production System – the intuitive operating concept of the Layout Designer lets you create even complex designs and system layouts in no time at all.

Components can be selected from the range of products using drag & drop and assembled quickly and easily using the snap function. You can then conveniently order the components needed for your configuration online. With the automatic parts list pricing feature, you'll always have a handle on costs. Numerous interfaces allow the planning data to be used by other departments, such as Design, Purchasing and Service.

Everything’s well in hand with MTpro

From technical data to ordering information and CAD models through to assembly instructions and spare parts illustrations, the MTpro planning software shows you everything you need to plan and design frames, enclosures, flow racks, workstations or transfer systems at a glance.

Intuitively assemble your system on screen using drag & drop and the snap function – no complicated CAD program required. Optimize the ergonomics of your design with ease using the integrated ManModel. Generate entire parts lists, including accessories and all small parts, at the push of a button and then submit your order online. Versatile interfaces allow layouts, CAD models and order data to be conveniently used elsewhere.

Suitable for the whole range of assembly technology.

MTpro helps you to both design frames and enclosures with basic assembly elements, and to plan and ergonomically design Manual Production Systems. You can also produce layouts for entire chain conveyors and transfer systems in no time at all.

Design frames and enclosures made from Basic Mechanic Elements



Benefits

- Quickly plan complete frames without CAD software
- Easy assembly via drag & drop
- Library for reusing your previous modules and layouts

Design ergonomic Manual Production Systems with ManModel

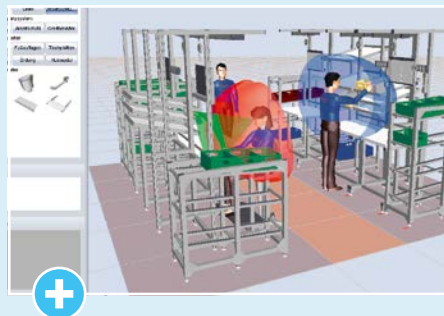

Benefits

- Simulation of grab areas and fields of view using standardized human models for optimal workstation ergonomics
- Female and male models, small, medium and tall in stature

Plan transfer system layouts



Benefits

- Layout Designer for planning complete conveyor systems
- Assembly logic assists in quick and flawless component assembly
- System environment factored in with the option of adding room elements

FRAMEpro – The intelligent CAD plug-in



With the FRAMEpro CAD plug-in, Bosch Rexroth brings its proven modular aluminum profile system for machine frames and housings into the Autodesk® Inventor CAD environments and SolidWorks from Dassault.



With the FRAMEpro CAD plug-in, Bosch Rexroth brings its proven modular aluminum profile system for machine frames and housings into the Autodesk® Inventor CAD environments and SolidWorks from Dassault.

Simple

FRAMEpro also automatically generates a parts list for your model so that you can request a quote or place an order. Once the construction process is complete, FRAMEpro utilizes our Quick & Easy part numbering system to indicate the strut profiles used, including the necessary cutting and drilling.

Fast

FRAMEpro supports design engineers and planners with practical search, sort and filter function. The selected profiles are placed in a 3D line model – centrally or with an offset – and can also be rotated. Accessories such as connectors, cover caps, bases and wheels can then be placed on the profiles.

Reliable

FRAMEpro complements the relevant CAD environment by adding a library which is updated by Bosch Rexroth on an ongoing basis. All models and data it contains are therefore up to date at all times. Because CAD data no longer need to be transferred from external sources, manual imports, transmission errors or duplicate data are now a thing of the past.

BENEFITS FOR YOU

-  Working in a familiar CAD environment saves time during the design process
-  Reliable design planning reduces engineering costs
-  Straightforward data exchange thanks to part lists which are automatically created and the quick transfer of inquiries and quotations
-  Integrated component library with approx. 1500 products
-  Plausibility checks
-  Automatically produced parts and order lists

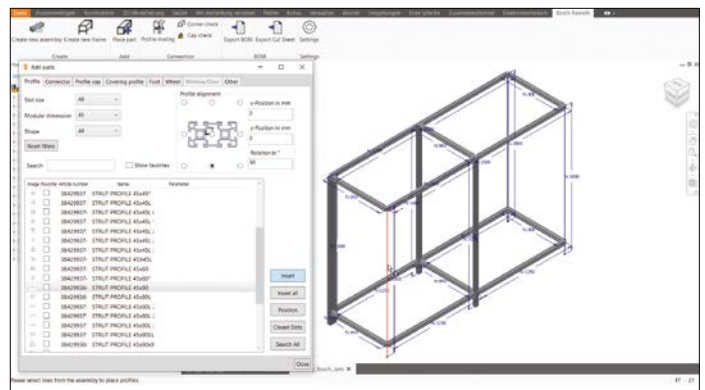
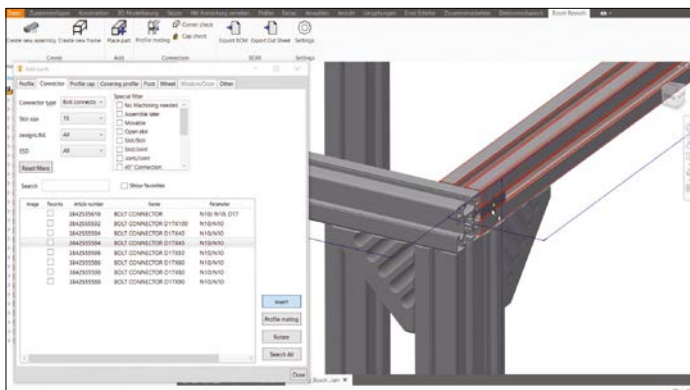

Tightening Technology: Platform 350 tightening systems – reliability for industrial applications



Nexo cordless Wi-Fi nutrunner

- Integrated controller, servo amplifier, Wi-Fi connectivity, and on-board data storage provide a high degree of functionality
- Cordless freedom provides excellent ergonomic and productivity benefits, even in hard to reach areas
- Maximum process reliability due to digital torque and angle sensor

Handheld nutrunner ErgoSpin

- Ergonomic handheld design and exceptional weight balance reduce operator fatigue and boost productivity
- Integrated torque and angle sensors provide a high level of process reliability and industry leading accuracy
- Robust digital maintenance free construction maximizes uptime

OPEXplus digital torque wrench

- Integrated controller provides full functionality + Wi-Fi connectivity to host systems.
- Covers a range of torques from 3 to 800 Nm
- Supports popular protocols such as OpenProtocol, IPM or XML
- Ergonomic design provides excellent feedback via a 360 degree LED ring, color HMI, and vibrating buzzer

Handheld, manual, semi or fully automatic – electric tightening systems by Rexroth are the efficient and secure solution for your production needs.

Process control, accuracy and the highest level of flexibility are critical components to every production and assembly line. The correct fastener must be tightened to both the exact torque and required angle. Only then does an assembly reliably meet the quality standards for the final product.

Requirements concerning tightening systems in the automotive industry as well as in plant and mechanical engineering are clearly defined by VDI/VDE 2862. Thanks to the accuracy of electric tightening systems by Rexroth and the ability to document each and every bolt while compiling statistics for quality assurance, you can rest assured that your process is reliable and in control.



Compact systems

- Available for both handheld tools and mounted spindles
- Display and status LEDs provide clear information for operators
- Easy programming via an intuitive operating system
- Protection class IP54, highest immunity to electromagnetic disturbances (EMC level IV)



Modular systems

- For handheld nutrunners, tightening spindles, or mixed operation
- Supports a wide range of communication protocols for flexible system integration
- Available as system box (IP54) or as control rack for switch cabinet
- Up to 40 tightening channels can be combined by linking multiple systems



BS350 Operating systems

- Icon-based programming and intuitive interface make it easy to learn and easy to use
- Automatic detection of electronic components
- Transparent tightening case analysis thanks to clear graphic display



Tightening spindles

- Meets the highest safety requirements with redundancy measurements conforming to VDI standards
- High performance for the most demanding applications in either hand-guided or automated assembly systems

Bosch EXACT and C-EXACT Tools: Clutch-based solutions for Industrial Applications

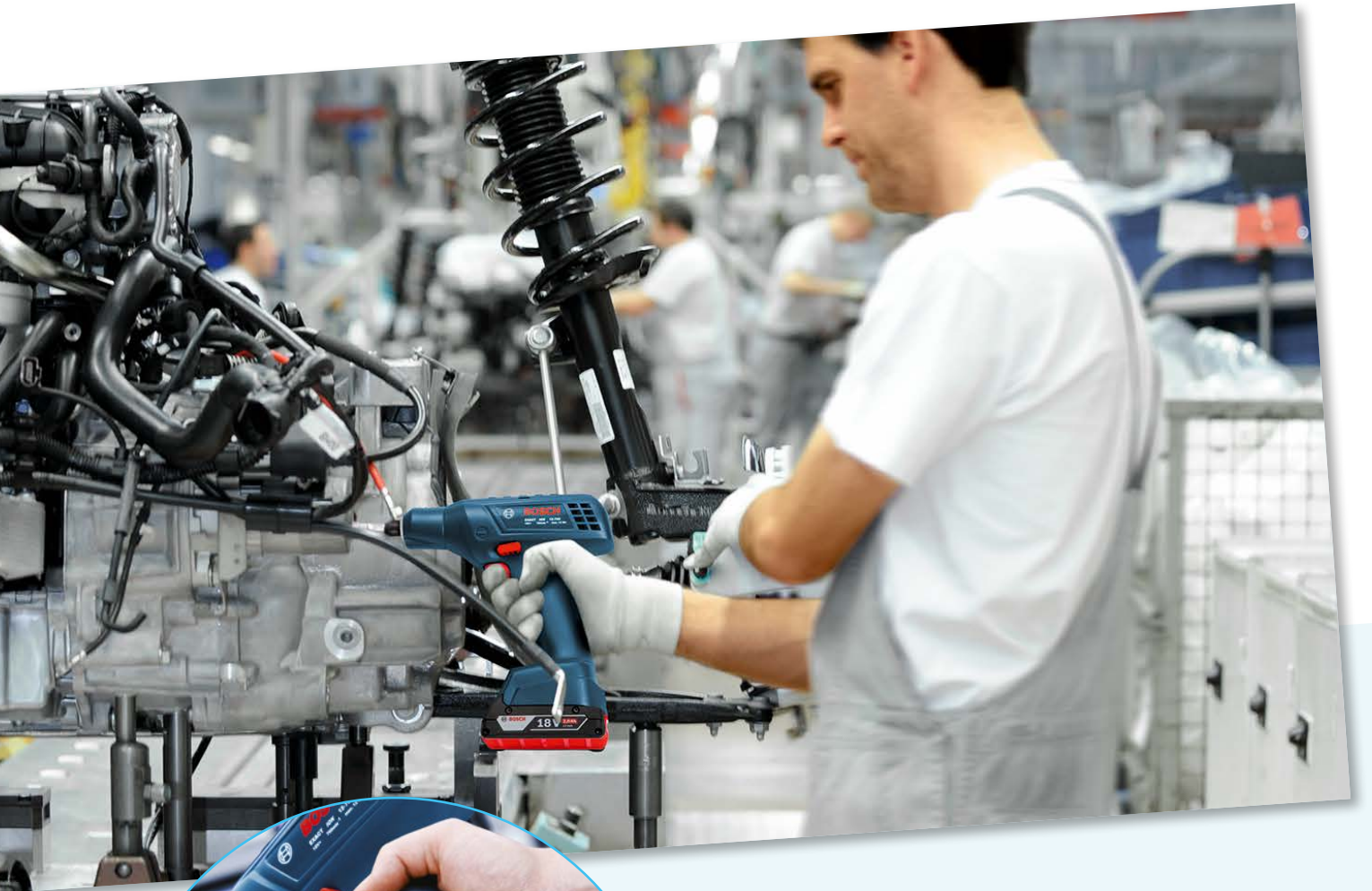

The EXACT tools from Bosch are cordless clutch based solutions developed specifically for industrial applications – offering the highest level of accuracy, durability, and efficiency available. In assembly applications where cables or pneumatic hoses get in the way, the EXACT series enables you to optimize processes, build better products, and reduce your costs. Available in 18V and an all new 12V platform, these tools utilize the powerful Bosch Core battery technology for the ultimate in runtime and performance.



C-EXACT Corded Electric tools: Low-voltage operation, brushless EC motor technology, and critical components from the EXACT series make the C-EXACT electric screwdrivers a cost-effective corded option loaded with innovative performance features. The clutch for example offers a 15% torque boost in reverse to assist in loosening stubborn overtightened screws. The integrated torque mechanism offers class leading accuracy, is extremely robust, and can be adjusted with the use of a special key. This prevents unauthorized or unintentional adjustment during normal operation, maintaining process security.

Whether assembling computer drives, electronics, appliances, or automobiles, the EXACT portfolio is the right choice when precision and durability is what matters most.



EXACT / C-EXACT Features and Benefits:

- **Bright LED light** for illuminating the work area
- **Easy Forward/Reverse operation** allows single handed operation
- **Anti-Repeat protection** minimizes double hit errors
- **Class leading power to weight ratio** provides faster/lighter performance
- **Balanced weight distribution** for better ergonomics
- **Industrial CORE battery** platforms provide the longest lifetime and global availability
- **12V & 18V platforms** new 12V platform includes smaller tools for tight applications
- **Programmable speed** from 10 to 100% in multiple steps
- **Torque adjustment** only with a special tool
- **Highest repeatability** due to Bosch clutch design
- **Easy service** due to plug connectors and common parts
- **Bosch motors:** brushless motor technology
- **Visual and audible signals** provide information about battery status and screwdriving quality
- **Colored marking rings** for easy identification

Tightening Technology Service: Explore More Service – Field service for tightening systems



+ We get you started

Rexroth field service can help you get your tightening systems up and running quickly and correctly from the very beginning. Initial training helps your team to operate and optimize your tightening systems.

- **Technical Training**
 - Find the ideal tool for your application
 - Quality features to support for Industry 4.0
 - Tightening programming; support & optimization
- **Commissioning**
 - On-site set up – our experts on site!
 - Programming and tuning/optimization
 - On-site machine capability test – ISO 17025
- **Consulting & Optimization**
 - Reduce failure rate & speed up cycle time
 - Remote analysis of tightening programs or in-field optimization

+ We keep you moving

Our new **Bosch Rexroth U.S. Repair Center of Competence** for tightening systems was established to support your needs locally with minimum turnaround time.

- **Local repairs of Rexroth tightening products**
 - Tightening spindles
 - Ergospin – Hand-held tools
 - Nexa – Hand-held wireless tools
- **Our repairs include full service of**
 - EC motor repair
 - Transducer repair and calibration
 - Repair of gear boxes and output drives
 - Machine capability test
- **Or choose our remanufacturing option**
 - Troubleshooting and replacement of failed parts
 - Replacement of all wear parts, cleaning and greasing
 - Recalibration and Machine Capability Test
 - Two year warranty for remanufactured tool/spindle



+ We keep you efficient

Rexroth technicians are here to optimize your production quality. Periodical validation of your tools and preventative product maintenance keep you up, running and safe.

Validation (Machine Capability Test)

- Available for Bosch Rexroth, Bosch and third party tightening tools
- Validation of different targets, like torque and angle
- According to your preferences, validation on site or in Bosch Rexroth laboratory possible
- If your tool is found out of tolerance during validation, adjustment and repair (in Rexroth lab) available
- Accredited validation, according to ISO 17025 and VDI/VDE 2645 Standards
- Original manufacturer's data and tolerances are applied

Preventative maintenance

After running your tool 1,000,000 cycles, we recommend a check-up! The check-up includes:

- Replacement of worn parts
- Cleaning and greasing
- Recalibration of transducer
- Machine capability test

Rexroth Service – your key to higher productivity



Maximum system availability and top efficiency throughout the entire life cycle of your machinery and systems: These key factors determine the productivity of your production processes. Rexroth provides comprehensive services that allow you to achieve these goals regardless of location, sector or equipment. All this implemented by our highly qualified personnel in 80 countries.

Put together your custom service package – from simple spare parts supply to technical services. We're here for you.

You can find detailed information on Rexroth services at www.boschrexroth-us.com/assembly-tech-service



If you desire, we will keep your machinery in peak condition over its entire life cycle and increase your efficiency to the latest standard. Together with you, we will analyze your upgrade and retrofitting potential, and also take practical steps to implementing it. Your operating costs will drop dramatically thanks to higher productivity, greater energy efficiency and ideal safety standards. Increase the productivity of your machinery and systems for good with Rexroth as your service partner.

Take the guesswork out of maintenance – our experts will give you peace of mind that your equipment will stay up and running, so you can focus on what's important.

Levels of service contracts available:

- Essential
- Advanced
- Premium
- Customized

Rexroth Service – Get your systems running quickly and correctly

Count on our expert field technicians to keep the Rexroth conveyors, AMRs, and tightening tools in your factory automation systems running with peak efficiency and accuracy. Only Bosch Rexroth has the factory-authorized repair systems and factory-trained service personnel to ensure that all your assemblies are built and maintained to their original performance specification.

SERVICE FOR ASSEMBLY TECHNOLOGY

TS Conveyors

Our highly-trained field service technicians are here to help with on-site assembly and installation of TS conveyor systems—so your team can focus on what’s important. Or ask one of expert technicians to support your local team with installation. After installation, keep your conveyors running smoothly with maintenance contracts, spare part recommendations, and tune-up services.



VarioFlow plus

With Rexroth Service, get on-site installation support from our highly-trained technicians. Then, keep production moving with VarioFlow *plus* conveyor maintenance, tune-up service and spare part recommendations. Let a factory-trained and authorized Bosch Rexroth technician come to your site and perform a detailed function check of each component on your installed system, as well as check for operating conditions that may lead to downtime.



Tightening Systems

Rexroth field service can help you get your tightening systems up and running quickly and correctly from the very beginning. Initial training and on-site machine capability testing help your team to operate and validate your Rexroth tightening systems to ISO 17025 standards.



ACTIVE Mover & FTS

Get your ACTIVE Mover or FTS system up and running quickly and correctly with Rexroth’s expert field service. Once it’s up, our team can also assist with preventative maintenance and field service support to help avoid cost machine downtime.



Connected assembly and logistics: From customer-specific solution to turnkey project



From consulting and total installation acceptance through to personnel training: Rexroth is there for you around the globe in every phase of planning, designing and implementing your factory automation projects focusing on connected assembly and logistics.

CUSTOMIZED AND APPLICATION-ORIENTED

When developing the most cost-effective and productive solutions, we turn to our field-tested digitization/Industry 4.0 technologies and innovations. These include collaborative robotics systems and intelligent software solutions, e.g. for employee guidance and support, performance management and quality assurance. To accomplish this, we also integrate systems into your IT infrastructure and ensure interfaces are designed effectively (e.g. for connecting to MES and ERP systems).

At Bosch Rexroth, Industry 4.0 is already a living reality: We are simultaneously the leading provider of components and systems on the market and the leading user in over 270 Bosch plants worldwide. Benefit from our extensive expertise and the wealth of experience that makes its way into our products and your projects.

Our skilled customer consulting is informed by this understanding and even factors in every aspect of modern, lean and scalable production design. The result of our services are overall solutions that meet all of your needs and will continue to do so into the future. With our global network, we will always be at your side as a reliable, long-term partner.

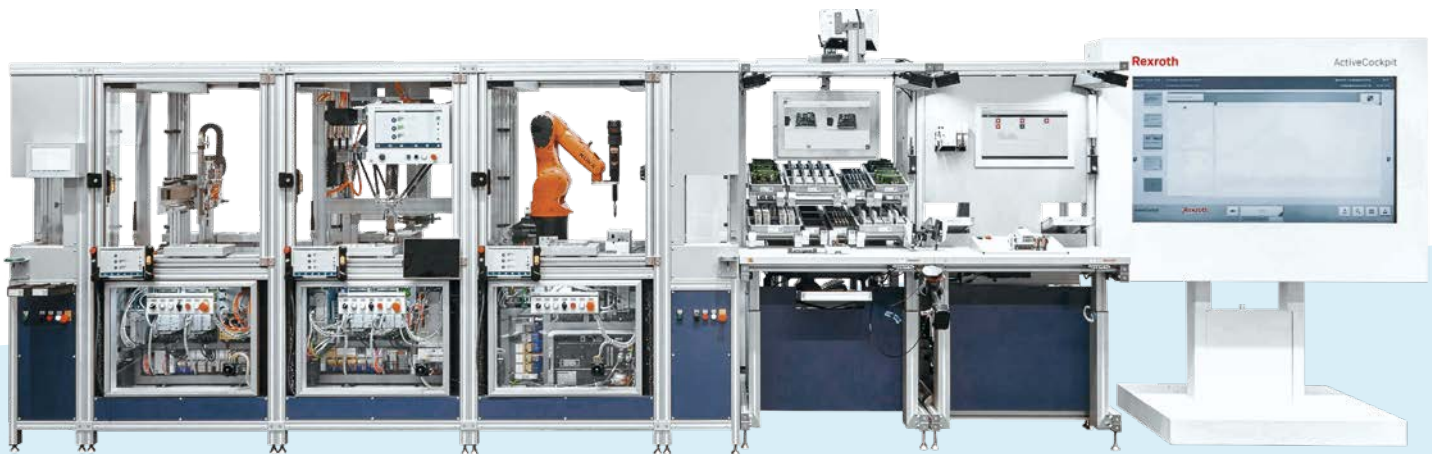

OUR SERVICES – OUR APPROACH

PLANNING



Active collaboration in the planning phase
Value stream analysis

DESIGN



Concept development
Value stream and IT design
Layout and processes

IMPLEMENTATION



Engineering and design
Production, procurement, assembly
Installation, startup and IT integration

SERVICE



Comprehensive services
Production optimization



BENEFITS FOR YOU

- ▶ Everything from a single source; turnkey assemblies
- ▶ Total project planning and management across all assemblies
- ▶ Value stream-optimized layout based on extensive production experience
- ▶ Reliable partner with an international presence
- ▶ Subassembly delivery based on project progress
- ▶ Transparent quality management/documentation, incl. safety assessment of overall system
- ▶ Transfer of risk at destination on request
- ▶ Project-specific warranty and service agreements

Sample projects

Linkage of TS 2plus and TS 1 for plant transport



Industry 4.0 assembly line



Linkage of Vario-Flow 90 for automotive transmission chip removal



Linkage of TS 2pv for solar panel manufacturing



Bosch Rexroth Corporation

Corporate Headquarters
14001 South Lakes Drive
Charlotte, NC 28273
Phone (800) REXROTH
(800) 739-7684
info@boschrexroth-us.com
www.boschrexroth-us.com

Find your local contact person here

www.boschrexroth-us.com/contactus

Further information online:



At the Bosch Rexroth website

www.boschrexroth-us.com/assembly-technology



Rexroth media directory

Commercial media and technical documentation
is available for download 24/7 from:
www.boschrexroth.com/mediadirectory

The data specified above only serves to describe the product. Due to the ongoing development of our products, no statements concerning a certain condition or suitability for a certain application can be derived from our information. The information given does not release the user from the obligation of own judgment and verification. It must be remembered that our products are subject to a natural process of wear and aging.

USA00050/08.2023
Replaces: 04.2023
© Bosch Rexroth Corporation 2023
Subject to revisions!

