

Rexroth

Tightening Systems





| | | | |
|----------|--|------------|--|
| 4 | FACTORY OF THE FUTURE – CONNECTED TIGHTENING TECHNOLOGY | 110 | CONTROL AND POWER ELECTRONICS |
| | | 112 | Compact system |
| | | 118 | Modular system |
| | | 120 | System box |
| | | 122 | Card rack |
| | | 129 | Accessories for control and power electronics |
| | | 130 | Control cabinets |

| | | | |
|----------|---------------------------------------|------------|--------------------------|
| 6 | TIGHTENING SYSTEMS AT A GLANCE | 132 | INTERFACE MODULES |
|----------|---------------------------------------|------------|--------------------------|

| | | | |
|----------|-------------------------------------|------------|---------------|
| 8 | TIGHTENING SPINDLES | 136 | CABLES |
| 12 | Tightening spindles size 2 | | |
| 28 | Tightening spindles size 3 | | |
| 48 | Tightening spindles size 4 | | |
| 68 | Tightening spindles size 5 | | |
| 76 | Accessories for tightening spindles | | |

| | | | |
|-----------|--|------------|--------------------------------------|
| 78 | CUSTOMIZED SOLUTIONS AND PROJECTS | 144 | SOFTWARE AND OPERATING SYSTEM |
|-----------|--|------------|--------------------------------------|

| | | | |
|-----------|--|------------|---------------------------------|
| 82 | ERGOSPIN HAND-HELD NUTRUNNERS | 150 | OPERATOR GUIDANCE SYSTEM |
| 94 | Accessories for hand-held nutrunners ErgoSpin / CC-ErgoSpin | | |
| 99 | Angle compensation function | | |

| | | | |
|------------|---|------------|----------------|
| 100 | NEXO – INTELLIGENT CORDLESS NUTRUNNERS | 152 | SERVICE |
| 104 | Nexo – angle heads | | |
| 105 | Nexo – accessories and extensions | | |
| 109 | NEXO-OS – browser-based operating system | | |

| | | | |
|--|--|------------|--|
| | | 154 | ASSEMBLY TECHNOLOGY AT A GLANCE |
|--|--|------------|--|

| | | | |
|--|--|------------|--|
| | | 158 | RATING OF A TIGHTENING CONNECTION |
|--|--|------------|--|

| | | | |
|--|--|------------|-----------------------------|
| | | 159 | CLAMPING FORCE TABLE |
|--|--|------------|-----------------------------|

| | | | |
|--|--|------------|-----------------|
| | | 160 | GLOSSARY |
|--|--|------------|-----------------|

**WE MOVE.
YOU WIN.**

Factory of the Future – connected tightening technology

The factory of the future. What will it look like? Bosch Rexroth has very clear ideas about it. They are based on experiences with networking more than 270 plants of the Bosch Group and numerous projects with other companies. In the factory of the future, only the floor, the walls and the roof cannot be changed. Machines, automation topologies and assembly lines adapt to new mobile requirements and constantly form new production lines. They communicate wirelessly with each other and with higher-level systems via open protocol that confirm to open standards.



How do you benefit from this? You increase transparency in mass production and continuously reduce costs. In a variety of production processes, you can produce the economically smallest quantities down to batch size 1. The best thing is that Bosch Rexroth's intelligent tightening technology is opening the path to the factory of the future for you today. It can already be integrated quickly, using wireless communication and common standards in networked environments.

Factory of the Future

Now. Next. Beyond.

MAXIMUM FLEXIBILITY

In the factory of the future, machines do not have cabinets and can be combined with minimum effort to form new production units at any time. They exchange wireless information, which can be processed optionally in machines, on production lines or in clouds – all prerequisites which the Nexo cordless nutrunner already fulfills. With Nexo, the controller is directly integrated in the nutrunner. It controls all processes and compares actual values with nominal values. The nutrunners communicate wirelessly via common protocols with higher-level systems and the browser-based operating software can be called up with any end devices. With the use of scanners, Nexo cordless nutrunners accommodate smallest quantities down to batch size 1 with ease.

DIGITIZED VALUE STREAM

Fully link your value stream with process data to the virtual world of information technology! The **Production Performance Manager** is an information and assessment system that systematically improves your production. The integrated **Process Quality Module** records and visualizes all tightening process data. This allows you to monitor your processes continuously, diagnose errors and detect wear before it causes a production stop.

The software supports you with real-time evaluations of all relevant production data to allow you to identify process risks very early and react more quickly to process errors. The result is complete transparency – the prerequisite for continuous improvement through to new business models which no longer require you to invest in operating resources. In fact, in the future you will only pay for value-add – for example correct and documented tightening processes. Let's talk about this!

Our experts actively advise and support you so that you're prepared to rise to the challenges of the factory of the future. Get in touch with us via factoryofthefuture@boschrexroth.com

Clever, flexible, secure: Rexroth tightening technology

Rexroth offers precise tightening technology – tools, control systems and the corresponding accessories – for all key tightening tasks in a wide variety of industries: from the intelligent cordless nutrunner, the ergonomic hand-held nutrunner, to the versatile tightening spindles and even the fully automatable tightening system.

Ethernet-based data/
control protocols

- ▶ FTP protocols
- ▶ Open protocol
- ▶ VW-XML protocol
- ▶ IPM protocol
- ▶ CAQTNG
- ▶ PLUS protocol
- ▶ QDA protocol
- ▶ HTTP

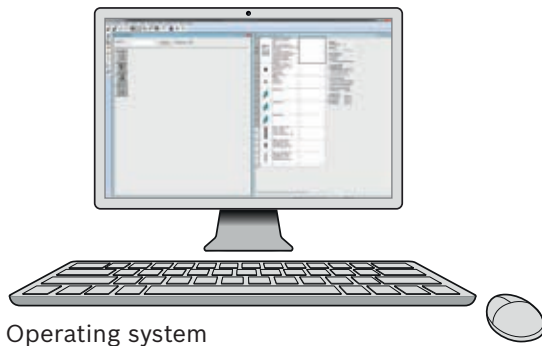

Operating system

ADVANTAGES OF THE SOFTWARE

- ▶ All in one software package includes an extensive and user-friendly statistics package.
- ▶ System installation and programming of individual tightening tasks is done via convenient, icon-supported tools.
- ▶ 180 curves are available for an analysis of the tightening joints.
- ▶ Step by step programming structure allows for a logical breakdown of the tightening rundown and easy identification where an issue occurs in the rundown process.
- ▶ Individual solutions can be found under "Customized solutions" on page 78.

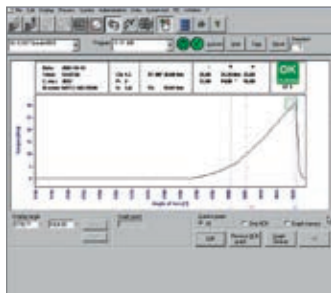

Graph

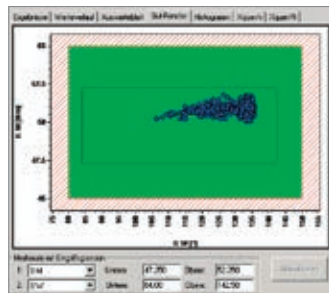

Good range window

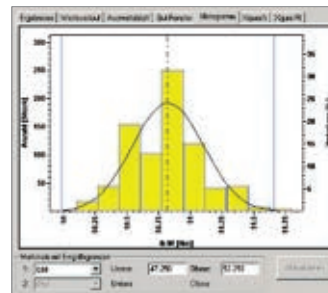

Histogram

| No. | Time | Result | Storage | Storage | Storage | Storage | Storage |
|-----|------|--------|---------|---------|---------|---------|---------|
| 1 | 0.00 | 0.00 | 0.00 | 0.00 | 0.00 | 0.00 | 0.00 |
| 2 | 0.00 | 0.00 | 0.00 | 0.00 | 0.00 | 0.00 | 0.00 |
| 3 | 0.00 | 0.00 | 0.00 | 0.00 | 0.00 | 0.00 | 0.00 |
| 4 | 0.00 | 0.00 | 0.00 | 0.00 | 0.00 | 0.00 | 0.00 |
| 5 | 0.00 | 0.00 | 0.00 | 0.00 | 0.00 | 0.00 | 0.00 |
| 6 | 0.00 | 0.00 | 0.00 | 0.00 | 0.00 | 0.00 | 0.00 |
| 7 | 0.00 | 0.00 | 0.00 | 0.00 | 0.00 | 0.00 | 0.00 |
| 8 | 0.00 | 0.00 | 0.00 | 0.00 | 0.00 | 0.00 | 0.00 |
| 9 | 0.00 | 0.00 | 0.00 | 0.00 | 0.00 | 0.00 | 0.00 |
| 10 | 0.00 | 0.00 | 0.00 | 0.00 | 0.00 | 0.00 | 0.00 |

Result window

Fieldbus connection via
Rexroth interface modules

- ▶ PROFIBUS DP
- ▶ DeviceNet
- ▶ PROFINET IO
- ▶ Modbus TCP
- ▶ Ethernet/IP
- ▶ EtherCat

Production Performance Manager
with Process Quality Module

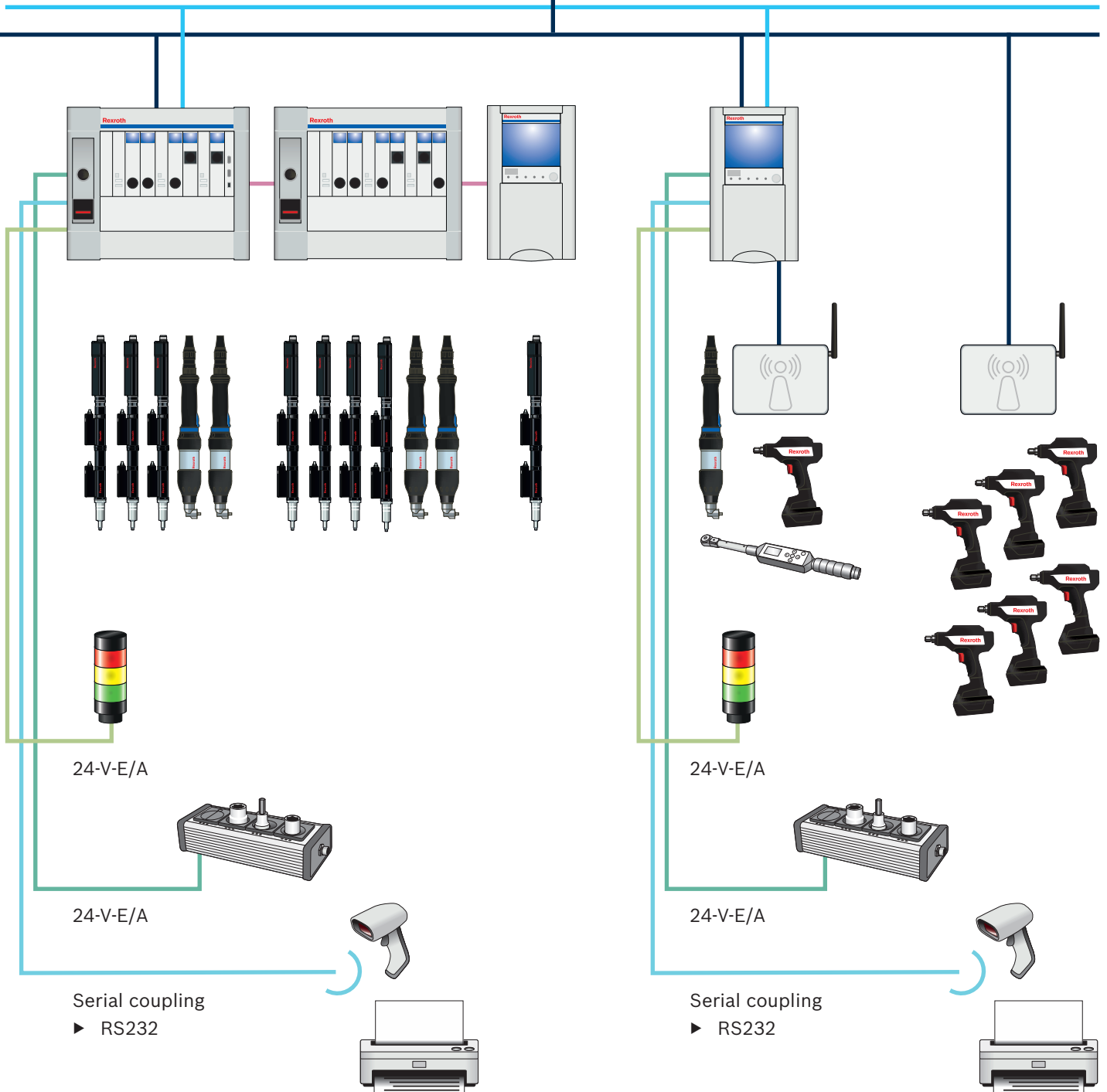

Tightening spindles 0.6–1,000 Nm



The modular construction of Rexroth tightening spindles enables a very precise adjustment to the tightening task at hand. Conformity with the VDI standard ensures that your tightening connections meet the highest safety requirements. The versatility of Rexroth tightening spindles not only guarantees safety but also a perfect design customized to your needs.



- ▶ Modular design, ideal adjustment to tightening case
- ▶ Maintenance-free for 1 million full-load cycles, long service life
- ▶ Process reliability and minimal waste thanks to real redundancy measurement
- ▶ Digital measurement transfer, maximum precision
- ▶ Largest working range
- ▶ Assured accuracy within the working range according to VDI/VDE 2647

Maximum flexibility in tightening spindle configuration – here are just some of the many options:



TIGHTENING SPINDLE WITH ANGLE HEAD

- ▶ For high accessibility
- ▶ Also available with integrated measurement transducer



TIGHTENING SPINDLE WITH OFF SET OUTPUT DRIVE

- ▶ For side-by-side arrangement with small center-to-center distances
- ▶ Also available with integrated measurement transducer



TIGHTENING SPINDLE WITH TRANSVERSE GEARBOX

- ▶ Compact length
- ▶ Available for all sizes



TIGHTENING SPINDLE WITH FEED OUTPUT DRIVE

- ▶ Integrated feed movement
- ▶ For use in connection with automatic bolt supply

Configure your tightening spindle

NUMEROUS OPTIONS

With a working range between 0.6 and 1,000 Nm (higher torques on request) and a choice between straight output drives, offset output drives, feed output drives, and angle heads – with Rexroth components you can configure a tightening spindle that is customized to your individual requirements.

We offer the offset output drive and angle head also with integrated measurement transducer. You can decide between having just one measurement transducer or working with an additional second redundant one. We can provide the optimum spindle components for any task. Why not find the perfect tightening spindle for your tightening connection?

Depending on the size, the actual components may differ from those in the illustration.

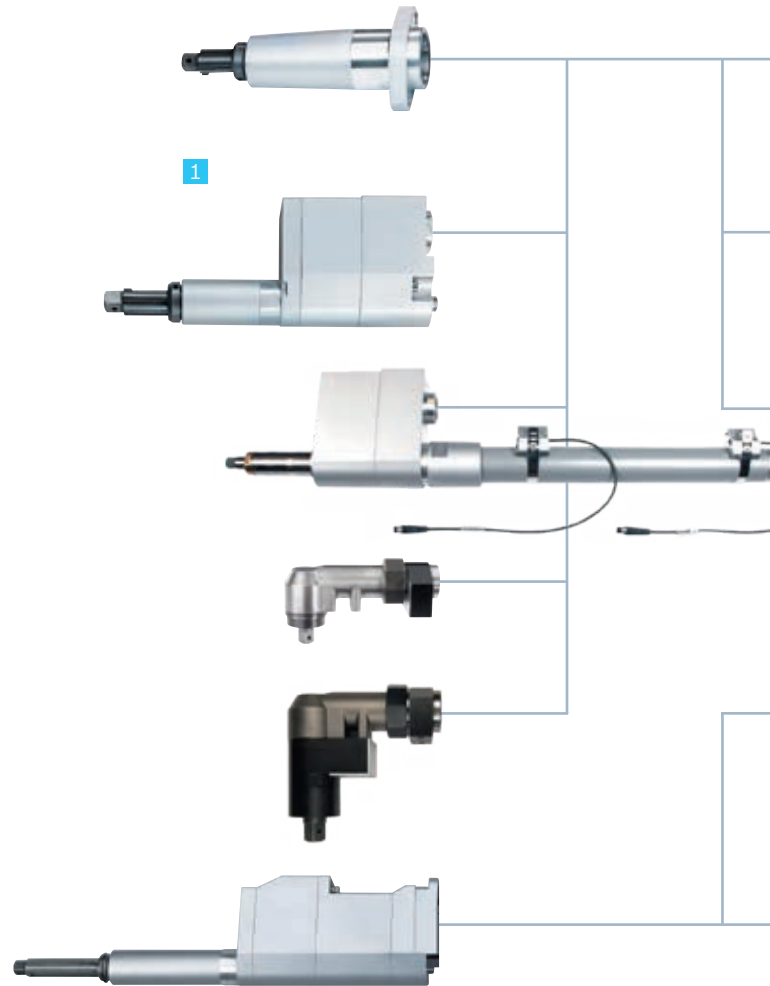

1 OUTPUT DRIVES

- ▶ The suitable output drive for every tightening position
- ▶ Special output drives for increased transverse forces, e.g. for wheel nutrunners, on request

2 ADAPTER A

- ▶ Connects planetary gearbox and output drive when operating without a measurement transducer

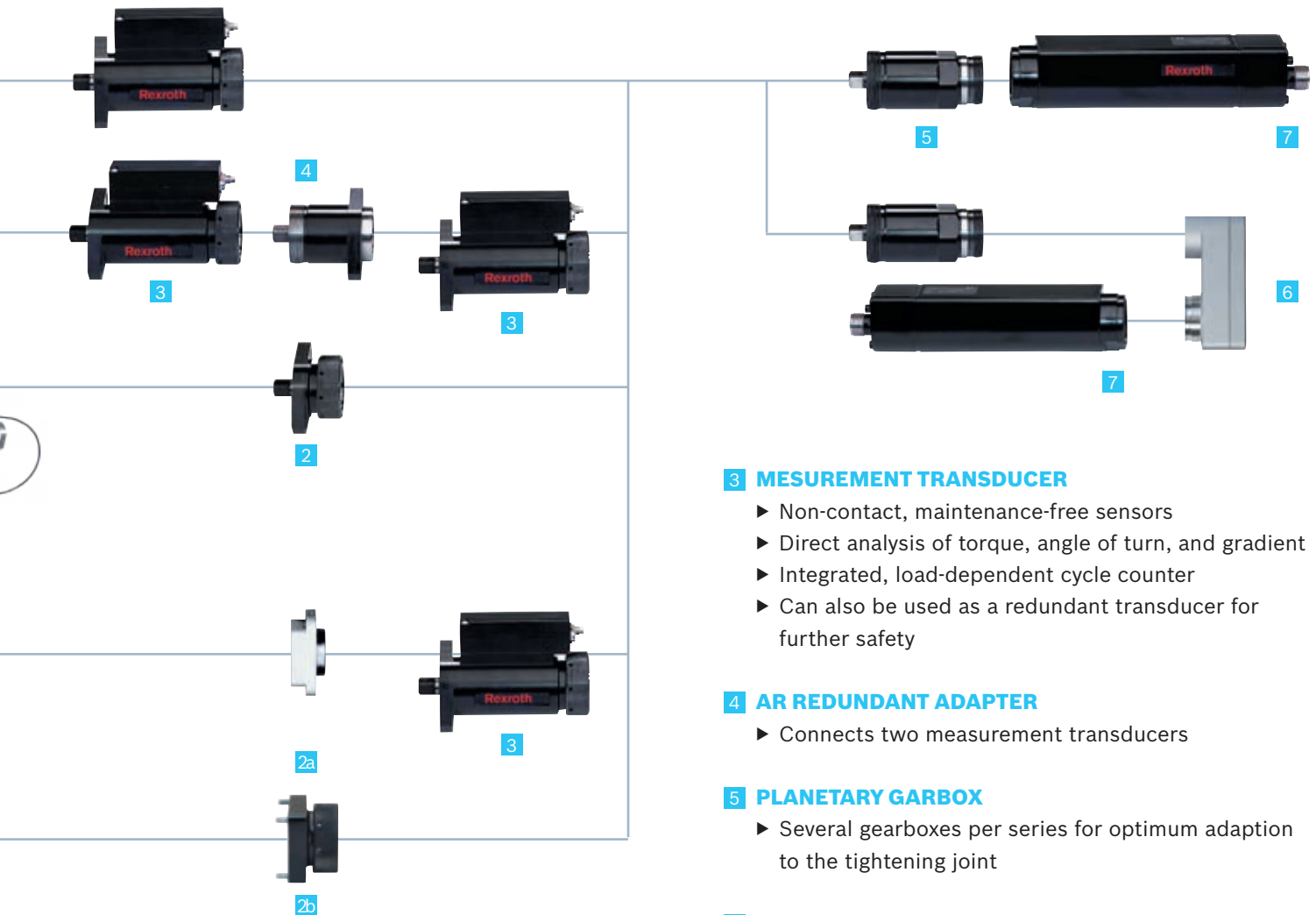
**2a AVR REDUNDANT ADAPTER**

- ▶ Connects an offset output drive with integrated transducer to a measurement transducer

2b AVG ADAPTER

- ▶ Connects an offset output drive with integrated transducer to a planetary gearbox when operating without a redundant measurement transducer

3 MESUREMENT TRANSDUCER

- ▶ Non-contact, maintenance-free sensors
- ▶ Direct analysis of torque, angle of turn, and gradient
- ▶ Integrated, load-dependent cycle counter
- ▶ Can also be used as a redundant transducer for further safety

4 AR REDUNDANT ADAPTER

- ▶ Connects two measurement transducers

5 PLANETARY GEARBOX

- ▶ Several gearboxes per series for optimum adaption to the tightening joint

6 TRANSVERSE GEARBOX

- ▶ Reduction of installation length

7 EC MOTOR

- ▶ Reliable
- ▶ Short tightening times
- ▶ Excellent dynamics
- ▶ High RPM
- ▶ Side-by-side arrangement due to small outer dimensions
- ▶ High density and power efficiency

Tightening spindles size 2

Spindle bearing



- ▶ Working range 0.6 – 10 Nm
- ▶ Max. output drive speed 1,000 rpm

Depending on the size, the actual components may differ from those in the illustration.

FEATURES

- ▶ Various lengths with axial compensator
- ▶ Standard tool mounts
- ▶ Maximum efficiency
- ▶ Maintenance-free for 1 million full-load cycles





| Tightening spindle | | Spindle bearing | | | | Measurement transducer | Planetary gearbox | EC motor |
|--------------------|-------------------------|---------------------------------------|-------------------------|----------|------------|------------------------|---------------------|---------------------|
| Working range* | Max. output drive speed | Range of spring mm/ max. spring force | Tool mount | Code | Order no. | Code / Order no. | Code / Order no. | Code / Order no. |
| Nm | rpm | N | | | | | | |
| 0.6–5.6 | 1,000 | 20/34.1 | 1/4" square drive | 2GA82 | 0608800077 | 2DMC006 0608820110 | 2GE19 0608720043 | EC302 0608701016 |
| | | | 1/4" quick-change chuck | 2GB82 | 0608800078 | | | |
| | | | | 2GB82F73 | 0608800085 | | | |
| | 780 | 20/34.1 | 1/4" square drive | 2GA82 | 0608800077 | | 2GE26 0608720038 | |
| | | | 1/4" quick-change chuck | 2GB82 | 0608800078 | | | |
| | | | | 2GB82F73 | 0608800085 | | | |
| 1.2–10 | 1,000 | 20/34.1 | 1/4" square drive | 2GA82 | 0608800077 | 2DMC012 0608820111 | 2GE19 0608720043 | |
| | | | 1/4" quick-change chuck | 2GB82 | 0608800078 | | | |
| | | | | 2GB82F73 | 0608800085 | | | |
| | 780 | 20/34.1 | 1/4" square drive | 2GA82 | 0608800077 | | 2GE26 0608720038 | |
| | | | 1/4" quick-change chuck | 2GB82 | 0608800078 | | | |
| | | | | 2GB82F73 | 0608800085 | | | |

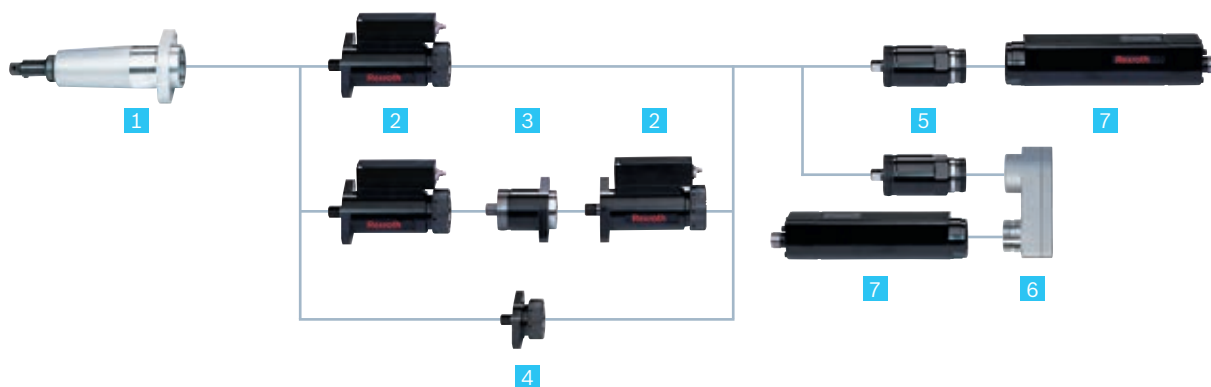

* The accuracy within the working range according to VDI/VDE 2647 is $\pm 2\%$ over 6 s.





Note: You can find component dimensions and 3D/CAD data on the Internet at www.boschrexroth.com/tightening

Spindle bearing size 2 – components



| | | | | | |
|--|---------------------|----------------|----------------|---|-------|
| 1 Spindle bearing  | Code | 2GA82 | 2GB82 | 2GB82F73 | |
| | Order no. | 0 608 800 077 | 0 608 800 078 | 0 608 800 085 | |
| | Max. torque | Nm | 10 | 10 | 10 |
| | Range of spring | mm | 20 | 20 | 20 |
| | Spring force | N | 16–34 | 16–34 | 22–73 |
| | Reduction | | 1 | 1 | 1 |
| | Avg. efficiency | | 1 | 1 | 1 |
| | Length A | mm | 82 | 82 | 82 |
| | Installation length | mm | 90 | 90 | 90 |
| Weight | kg | 0.2 | 0.2 | 0.2 | |
| 2 Measurement transducer  | Code | 2DMC006 | 2DMC012 | | |
| | Order no. | 0 608 820 110 | 0 608 820 111 | You can configure your tightening spindle with a redundant measurement transducer from the same type. Connect both measurement transducers with the redundant adapter. For measurement transducer cables, see page 140. | |
| | Nominal torque | Nm | 6 | 12 | |
| | Reduction | | 1 | 1 | |
| | Avg. efficiency | | 1 | 1 | |
| | Installation length | mm | 118.5 | 118.5 | |
| Weight | kg | 0.55 | 0.55 | | |
| 3 Redundanzadapter  | Code | 2AR | | | |
| | Order no. | 0 608 810 020 | | When configuring with a redundant measurement transducer, the adapter connects both measurement transducers. | |
| | Reduction | | 1 | | |
| | Avg. efficiency | | 1 | | |
| | Installation length | mm | 50 | | |
| Weight | kg | 0.3 | | | |
| 4 Adapter  | Code | 2A | | | |
| | Order no. | 0 608 810 024 | | When configuring without a measurement transducer, the adapter connects the output drive and the planetary gearbox. | |
| | Reduction | | 1 | | |
| | Avg. efficiency | | 1 | | |
| | Installation length | mm | 30 | | |
| Weight | kg | 0.4 | | | |

| | | | | | |
|--|---------------------|--------------|--------------|--|--|
| 5 Planetary gearbox  | Code | 2GE19 | 2GE26 | | |
| | Order no. | 0608720043 | 0608720038 | | |
| | Reduction | 18.9 | 25.5 | | |
| | Avg. efficiency | 0.93 | 0.9 | | |
| | Installation length | mm | 50.9 | 50.9 | |
| | Weight | kg | 0.4 | 0.4 | |
| 6 Transverse gearbox  | Code | 2ULG | | | |
| | Order no. | 0608810054 | | The transverse gearbox shortens the length of your tightening spindle by the installation length of the EC motor plus the installation length of the transverse gearbox. | |
| | Reduction | 1 | | | |
| | Avg. efficiency | 0.95 | | | |
| | Installation length | mm | 28.3 | | |
| | Weight | kg | 0.4 | | |
| | | | | | |
| 7 EC motor  | Code | EC302 | | | |
| | Order no. | 0608701016 | | | |
| | Installation length | mm | 197 | | |
| | Weight | kg | 0.72 | | |

| Side-by-side arrangement of tightening spindles (center-to-center distance) | | | | | | |
|---|-------|---|---|---|---|---|
| Number of tightening spindles | | 2 | 3 | 4 | 5 | 6 |
| | |  |  |  |  |  |
| Min. circle diameter- $\varnothing d_{\min}$ mm | 2G... | 35 | 40 | 55 | 66 | 74 |

Tightening spindles size 2

Offset output drive



- ▶ Working range 0.6 – 10 Nm
- ▶ Max. output drive speed 1,000 rpm

Depending on the size, the actual components may differ from those in the illustration.

FEATURES

- ▶ For tight hole templates, side-by-side arrangement with small center-to-center distances
- ▶ Standard tool mounts
- ▶ Maintenance-free for 1 million full-load cycles





| Tightening spindle | | Offset output drive | | | | Measurement transducer | Planetary gearbox | EC motor |
|--------------------|-------------------------|---------------------|-------------------------|--------|------------|------------------------|---------------------|---------------------|
| Working range | Max. output drive speed | Range of spring | Tool mount | Code | Order no. | Code/Order no. | Code/Order no. | Code/Order no. |
| Nm | rpm | mm | | | | | | |
| 0.6*–5.1 | 1,000 | 20 | 1/4" square drive | 2VNA82 | 0608800607 | 2DMC006 0608820110 | 2GE19 0608720043 | EC302 0608701016 |
| | | | 1/4" quick-change chuck | 2VNB82 | 0608800608 | | | |
| | 780 | 20 | 1/4" square drive | 2VNA82 | 0608800607 | | 2GE26 0608720038 | |
| | | | 1/4" quick-change chuck | 2VNB82 | 0608800608 | | | |
| 1.2*–10 | 1,000 | 20 | 1/4" square drive | 2VNA82 | 0608800607 | 2DMC012 0608820111 | 2GE19 0608720043 | |
| | | | 1/4" quick-change chuck | 2VNB82 | 0608800608 | | | |
| | 780 | 20 | 1/4" square drive | 2VNA82 | 0608800607 | | 2GE26 0608720038 | |
| | | | 1/4" quick-change chuck | 2VNB82 | 0608800608 | | | |

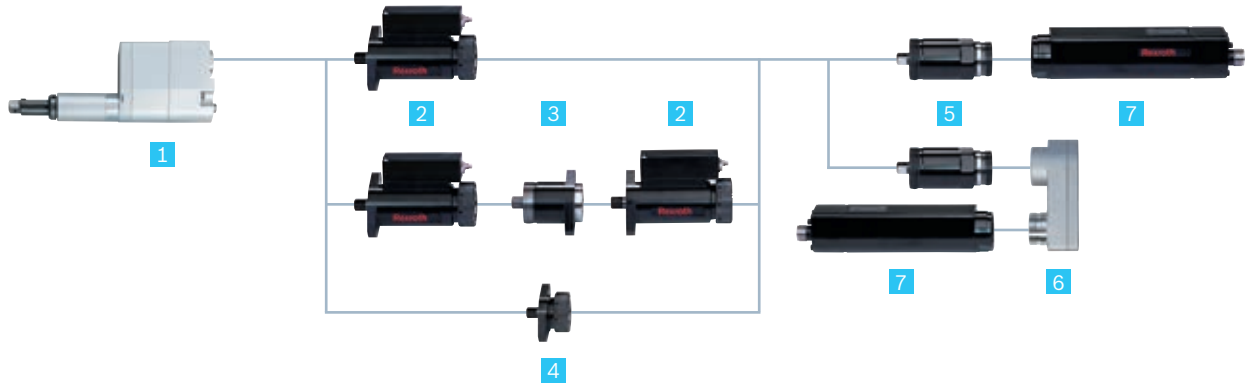

* Depending on the tolerance limits, position-based MCT required





Note: You can find component dimensions and 3D/CAD data on the Internet at www.boschrexroth.com/tightening

Offset output drive size 2 – components



| | | | | | |
|--|---------------------|----------------|----------------|---|-------|
| 1 Offset output drive  | Code | 2VNA82 | 2VNB82 | | |
| | Order no. | 0 608 800 607 | 0 608 800 608 | | |
| | Max. torque | Nm | 10 | 10 | |
| | Range of spring | mm | 20 | 20 | |
| | Spring force | N | 16–34 | 16–34 | |
| | Reduction | | 1 | 1 | |
| | Avg. efficiency | | 0.9 | 0.9 | |
| | Length A | mm | 82 | 82 | |
| | Installation length | mm | 153 | 153 | |
| Weight | kg | 0.6 | 0.6 | | |
| 2 Measurement transducer  | Code | 2DMC006 | 2DMC012 | | |
| | Order no. | 0 608 820 110 | 0 608 820 111 | You can configure your tightening spindle with a redundant measurement transducer from the same type. Connect both measurement transducers with the redundant adapter. For measurement transducer cables, see page 140. | |
| | Nominal torque | Nm | 6 | | 12 |
| | Reduction | | 1 | | 1 |
| | Avg. efficiency | | 1 | | 1 |
| | Installation length | mm | 118.5 | | 118.5 |
| Weight | kg | 0.55 | 0.55 | | |
| 3 Redundant adapter  | Code | 2AR | | When configuring with a redundant measurement transducer, the adapter connects both measurement transducers. | |
| | Order no. | 0 608 810 020 | | | |
| | Reduction | | 1 | | |
| | Avg. efficiency | | 1 | | |
| | Installation length | mm | 50 | | |
| Weight | kg | 0.3 | | | |
| 4 Adapter  | Code | 2A | | When configuring without a measurement transducer, the adapter connects the output drive and the planetary gearbox. | |
| | Order no. | 0 608 810 024 | | | |
| | Reduction | | 1 | | |
| | Avg. efficiency | | 1 | | |
| | Installation length | mm | 30 | | |
| Weight | kg | 0.4 | | | |

| | | | |
|--|---------------------|--------------|--|
| 5 Planetary gearbox  | Code | 2GE19 | 2GE26 |
| | Order no. | 0608720043 | 0608720038 |
| | Reduction | 18.9 | 25.5 |
| | Avg. efficiency | 0.93 | 0.9 |
| | Installation length | mm 50.9 | 50.9 |
| | Weight | kg 0.4 | 0.4 |
| 6 Transverse gearbox  | Code | 2ULG | |
| | Order no. | 0608810054 | The transverse gearbox shortens the length of your tightening spindle by the installation length of the EC motor plus the installation length of the transverse gearbox. |
| | Reduction | 1 | |
| | Avg. efficiency | 0.95 | |
| | Installation length | mm 28.3 | |
| | Weight | kg 0.4 | |
| | | | |
| 7 EC motor  | Code | EC302 | |
| | Order no. | 0608701016 | |
| | Installation length | mm 197 | |
| | Weight | kg 0.72 | |

| Side-by-side arrangement of tightening spindles (center-to-center distance) | | | | | |
|--|---|---|---|---|---|
| Number of tightening spindles | 2 | 3 | 4 | 5 | 6 |
| |  |  |  |  |  |
| Min. circle diameter- $\varnothing d_{\min}$ mm | 2VN...82 23 | 27 | 33 | 41 | 52 |

Tightening spindles size 2 Angle head



- ▶ Working range 2.2 – 11 Nm
- ▶ Max. output drive speed 1,000 rpm

Depending on the size, the actual components may differ from those in the illustration.

MERKMALE

- ▶ For restricted accessibility
- ▶ Precision tothing for high torque accuracy
- ▶ Incremental positioning (45° increments)
- ▶ Integrated fastening flanges

| Tightening spindle | | Angle head | | | Measurement transducer | Planetary gearbox | EC motor |
|--------------------|-----------------------------|-------------------|------|------------|------------------------|---------------------|---------------------|
| Working range Nm | Max. output drive speed rpm | Tool mount | Code | Order no. | Code/Order no. | Code/Order no. | Code/Order no. |
| 2.2–5.6 | 1,000 | 1/4" square drive | 2W11 | 0608810041 | 2DMC006 0608820110 | 2GE19 0608720043 | EC302 0608701016 |
| | 740 | 1/4" square drive | 2W11 | 0608810041 | | 2GE26 0608720038 | |
| 2.2–11 | 1,000 | 1/4" square drive | 2W11 | 0608810041 | 2DMC012 0608820111 | 2GE19 0608720043 | |
| | 740 | 1/4" square drive | 2W11 | 0608810041 | | 2GE26 0608720038 | |

Note: You can find component dimensions and 3D/CAD data on the Internet at www.boschrexroth.com/tightening

ANGLE HEAD WITH SPINDLE BEARING

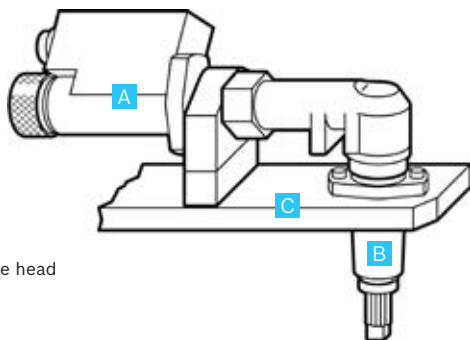

- A** Spindle with angle head
- B** Spindle bearing
- C** Mounting plate

AXIAL COMPENSATOR





To ensure troublefree operation, the angle head must always be operated with an output drive axial compensator, e.g. spindle bearing.

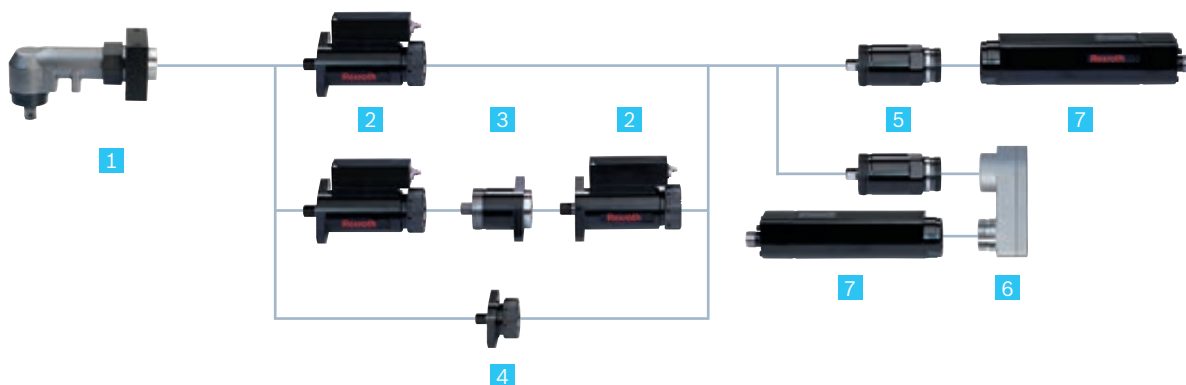

You can find more information in the planning instructions for angle heads in the Rexroth media directory at www.boschrexroth.com/mediadirectory.

For an output drive axial compensator, the following angle head/spindle bearing combination is possible:
2W011 (0608810041) – spindle bearing size 2 (page 14).





Angle head size 2 – components



| | | | | | |
|--|---------------------|----------------|----------------|---|-------|
| 1 Angle head  | Code | 2W011 | | | |
| | Order no. | 0608810041 | | | |
| | Max. torque | Nm | 11 | | |
| | Reduction | | 1.05 | | |
| | Avg. efficiency | | 0.95 | | |
| | Installation length | mm | 81.5 | | |
| | Weight | kg | 0.7 | | |
| 2 Measurement Transducer  | Code | 2DMC006 | 2DMC012 | | |
| | Order no. | 0608820110 | 0608820111 | You can configure your tightening spindle with a redundant measurement transducer from the same type. Connect both measurement transducers with the redundant adapter. For measurement transducer cables, see page 140. | |
| | Nominal torque | Nm | 6 | | 12 |
| | Reduction | | 1 | | 1 |
| | Avg. efficiency | | 1 | | 1 |
| | Installation length | mm | 118.5 | | 118.5 |
| Weight | kg | 0.55 | 0.55 | | |
| 3 Redundant adapter  | Code | 2AR | | | |
| | Order no. | 0608810020 | | When configuring with a redundant measurement transducer, the adapter connects both measurement transducers | |
| | Reduction | 1 | | | |
| | Avg. efficiency | 1 | | | |
| | Installation length | mm | 50 | | |
| Weight | kg | 0.3 | | | |
| 4 Adapter  | Code | 2A | | | |
| | Order no. | 0608810024 | | When configuring without a measurement transducer, the adapter connects the output drive and the planetary gearbox | |
| | Reduction | 1 | | | |
| | Avg. efficiency | 1 | | | |
| | Installation length | mm | 30 | | |
| Weight | kg | 0.4 | | | |

| | | | |
|--|---------------------|--------------|--|
| 5 Planetary gearbox  | Code | 2GE19 | 2GE26 |
| | Order no. | 0608720043 | 0608720038 |
| | Reduction | 18.9 | 25.5 |
| | Avg. efficiency | 0.93 | 0.9 |
| | Installation length | mm 50.9 | 50.9 |
| | Weight | kg 0.4 | 0.4 |
| 6 Transverse gearbox  | Code | 2ULG | |
| | Order no. | 0608810054 | The transverse gearbox shortens the length of your tightening spindle by the installation length of the EC motor plus the installation length of the transverse gearbox. |
| | Reduction | 1 | |
| | Avg. efficiency | 0.95 | |
| | Installation length | mm 28.3 | |
| | Weight | kg 0.4 | |
| | | | |
| 7 EC motor  | Code | EC302 | |
| | Order no. | 0608701016 | |
| | Installation length | mm 197 | |
| | Weight | kg 0.72 | |

Side-by-side arrangement of tightening spindles (center-to-center distance)

| Number of tightening spindles | 2 | 3 | 4 | 5 | 6 |
|--|---|---|---|---|---|
| |  |  |  |  |  |
| Min. circle diameter- $\varnothing d_{\min}$ mm | 2W011 26 | 30 | 36 | 44 | 52 |

Tightening spindles size 2

Feed output drive



- ▶ Working range 0.6 – 10 Nm
- ▶ Max. output drive speed 1,000 rpm

Depending on the size, the actual components may differ from those in the illustration.

FEATURES

- ▶ Integrated feed movement
- ▶ In connection with automatic bolt supply
- ▶ Standard tool mounts and compressed air connections
- ▶ Maintenance-free for 1 million full-load cycles





| Tightening spindle | | Feed output drive | | | | Measurement transducer | Planetary gearbox | EC motor |
|---------------------|--------------------------------|-------------------|-------------------|-------|-------------|------------------------|----------------------|----------------------|
| Working range Nm | Max. output drive speed rpm | Stroke mm | Tool mount | Code | Bestell-Nr. | Code/ Order no. | Code/ Order no. | Code/ Order no. |
| 0.6*–5.1 | 1,000 | 160 | M6 outer thread | 2S2M8 | 0608 800647 | 2DMC006 0608 820110 | 2GE19 0608 720043 | EC302 0608 701016 |
| | 780 | 160 | M6 outer thread | 2S2M8 | 0608 800647 | | 2GE26 0608 720038 | |
| | 1,000 | 160 | 1/4" square drive | 2S1M8 | 0608 800646 | | 2GE19 0608 720043 | |
| | 780 | 160 | 1/4" square drive | 2S1M8 | 0608 800646 | | 2GE26 0608 720038 | |
| 1.2*–7 | 1,000 | 160 | M6 outer thread | 2S2M8 | 0608 800647 | 2DMC012 0608 820111 | 2GE19 0608 720043 | |
| | 780 | 160 | M6 outer thread | 2S2M8 | 0608 800647 | | 2GE26 0608 720038 | |
| 1.2*–10 | 1,000 | 160 | 1/4" square drive | 2S1M8 | 0608 800646 | | 2GE19 0608 720043 | |
| | 780 | 160 | 1/4" square drive | 2S1M8 | 0608 800646 | | 2GE26 0608 720038 | |

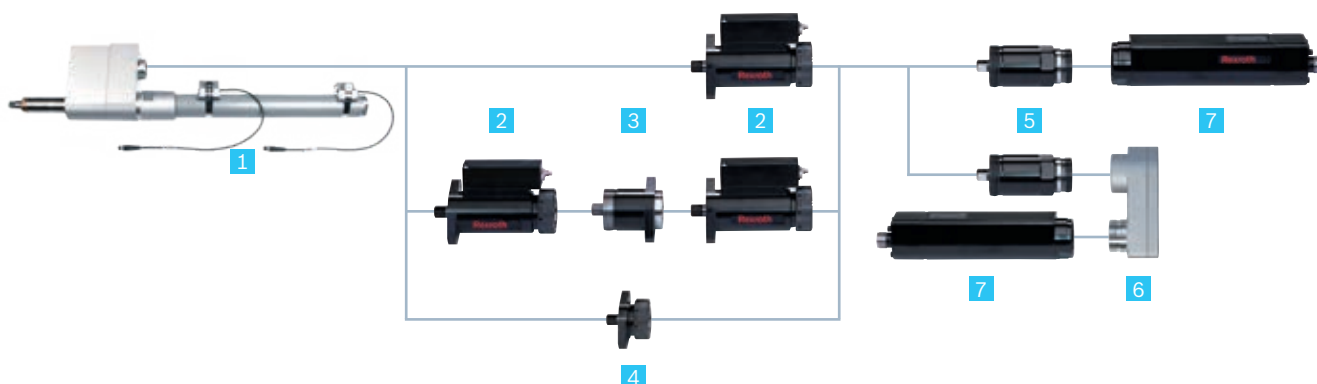

* Depending on the tolerance limits, position-based MCT required

Note: You can find component dimensions and 3D/CAD data on the Internet at www.boschrexroth.com/tightening





Feed output drive size 2 – components



| 1 Feed output drive | Code | 2S1M8 | 2S2M8 | |
|---|---------------------|---------------|---------------|---|
|  | Order no. | 0 608 800 646 | 0 608 800 647 | |
| | Max. torque | Nm 10 | 7 | |
| | Stroke | mm 160 | 160 | |
| | Max. air pressure | bar 4 | 4 | |
| | Reduction | 1 | 1 | |
| | Avg. efficiency | 0.93 | 0.93 | |
| | Length A | mm 80 | 80 | |
| | Installation length | mm 189.5 | 189.5 | |
| | Weight | kg 2 | 2 | |
| 2 Measurement transducer | Code | 2DMC006 | 2DMC012 | |
|  | Order no. | 0 608 820 110 | 0 608 820 111 | You can configure your tightening spindle with a redundant measurement transducer from the same type. Connect both measurement transducers with the redundant adapter. For measurement transducer cables, see page 140. |
| | Nominal torque | Nm 6 | 12 | |
| | Reduction | 1 | 1 | |
| | Avg. efficiency | 1 | 1 | |
| | Installation length | mm 118.5 | 118.5 | |
| | Weight | kg 0.55 | 0.55 | |
| 3 Redundant adapter | Code | 2AR | | |
|  | Order no. | 0 608 810 020 | | When configuring with a redundant measurement transducer, the adapter connects both measurement transducers. |
| | Reduction | 1 | | |
| | Avg. efficiency | 1 | | |
| | Installation length | mm 50 | | |
| | Weight | kg 0.3 | | |
| 4 Adapter | Code | 2A | | |
|  | Order no. | 0 608 810 024 | | When configuring without a measurement transducer, the adapter connects the output drive and the planetary gearbox. |
| | Reduction | 1 | | |
| | Avg. efficiency | 1 | | |
| | Installation length | mm 30 | | |
| | Weight | kg 0.4 | | |

| | | | |
|--|---------------------|--------------|--|
| 5 Planetary gearbox  | Code | 2GE19 | 2GE26 |
| | Order no. | 0608720043 | 0608720038 |
| | Reduction | 18.9 | 25.5 |
| | Avg. efficiency | 0.93 | 0.9 |
| | Installation length | mm 50.9 | 50.9 |
| | Weight | kg 0.4 | 0.4 |
| 6 Transverse gearbox  | Code | 2ULG | |
| | Order no. | 0608810054 | The transverse gearbox shortens the length of your tightening spindle by the installation length of the EC motor plus the installation length of the transverse gearbox. |
| | Reduction | 1 | |
| | Avg. efficiency | 0.95 | |
| | Installation length | mm 28.3 | |
| | Weight | kg 0.4 | |
| | | | |
| 7 EC motor  | Code | EC302 | |
| | Order no. | 0608701016 | |
| | Installation length | mm 197 | |
| | Weight | kg 0.72 | |

Side-by-side arrangement of tightening spindles (center-to-center distance)

| Number of tightening spindle | 2 | 3 | 4 | 5 | 6 |
|--|---|---|---|---|---|
| |  |  |  |  |  |
| Min. circle diameter- \varnothing d _{min} mm | 2S... 33 | 38 | 46 | 55 | 65 |

Tightening spindles size 3

Spindle bearing



- ▶ Working range 1.7 – 56 Nm
- ▶ Max. output drive speed 740 rpm

Depending on the size, the actual components may differ from those in the illustration.

FEATURES

- ▶ Various lengths with axial compensator
- ▶ Standard tool mounts
- ▶ Maximum efficiency
- ▶ Maintenance-free for 1 million full-load cycles





| Tightening spindle | | Spindle bearing | | | | Measurement transducer | Planetary gearbox | EC motor |
|--------------------|-------------------------|--|--------------------------------------|--------|------------|------------------------|---------------------|---------------------|
| Working range* | Max. output drive speed | Range of spring mm/ max. Spring force N | Tool mount | Code | Order no. | Code/ Order no. | Code/ Order no. | Code/ Order no. |
| Nm | rpm | | | | | | | |
| 1.7–16 | 740 | 25/39 | 3/8" square drive | G1A102 | 0608800062 | 3DMC017 0608820112 | 3GE27 0608720053 | EC303 0608701017 |
| | | | 1/4" quick-change chuck | G1B102 | 0608800063 | | | |
| | | | 3/8" square drive with centering pin | G1C102 | 0608800072 | | | |
| | | 50/38 | 3/8" square drive | G2A152 | 0608800064 | | | |
| | | | 1/4" quick-change chuck | G2B152 | 0608800065 | | | |
| | | | 3/8" square drive with centering pin | G2C152 | 0608800073 | | | |
| | 295 | 25/39 | 3/8" square drive | G1A102 | 0608800062 | 3DMC060 0608820113 | 3GE27 0608720053 | 3GE67 0608720039 |
| | | | 1/4" quick-change chuck | G1B102 | 0608800063 | | | |
| | | | 3/8" square drive with centering pin | G1C102 | 0608800072 | | | |
| | | 50/38 | 3/8" square drive | G2A152 | 0608800064 | | | |
| | | | 1/4" quick-change chuck | G2B152 | 0608800065 | | | |
| | | | 3/8" square drive with centering pin | G2C152 | 0608800073 | | | |
| 6–33 | 740 | 25/39 | 3/8" square drive | G1A102 | 0608800062 | 3DMC060 0608820113 | 3GE27 0608720053 | 3GE67 0608720039 |
| | | | 1/4" quick-change chuck | G1B102 | 0608800063 | | | |
| | | | 3/8" square drive with centering pin | G1C102 | 0608800072 | | | |
| | | 50/38 | 3/8" square drive | G2A152 | 0608800064 | | | |
| | | | 1/4" quick-change chuck | G2B152 | 0608800065 | | | |
| | | | 3/8" square drive with centering pin | G2C152 | 0608800073 | | | |
| 6–35 | 295 | 25/39 | 1/4" quick-change chuck | G1B102 | 0608800063 | 3DMC060 0608820113 | 3GE27 0608720053 | 3GE67 0608720039 |
| | | 50/38 | 1/4" quick-change chuck | G2B152 | 0608800065 | | | |
| 6–56 | 295 | 25/39 | 3/8" square drive | G1A102 | 0608800062 | 3DMC060 0608820113 | 3GE27 0608720053 | 3GE67 0608720039 |
| | | | 3/8" square drive with centering pin | G1C102 | 0608800072 | | | |
| | | 50/38 | 3/8" square drive | G2A152 | 0608800064 | | | |
| | | | 3/8" square drive with centering pin | G2C152 | 0608800073 | | | |

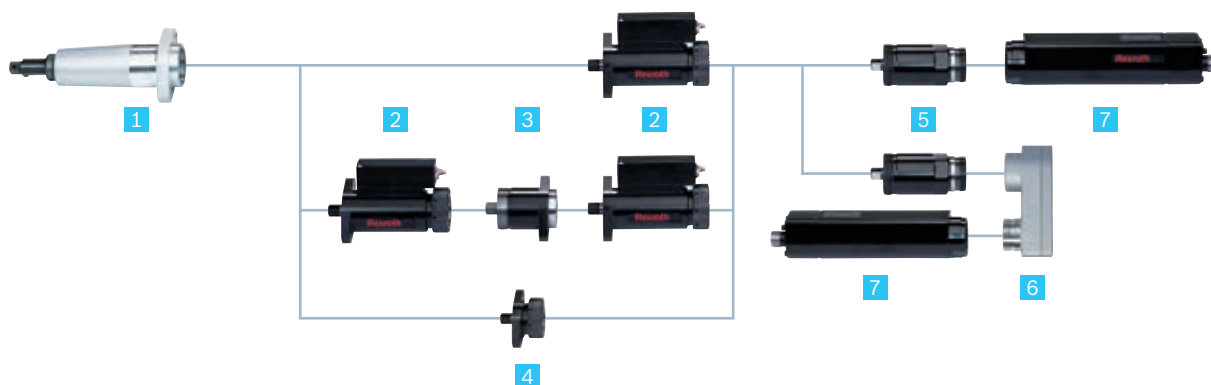

* The accuracy within the working range according to VDI/VDE 2647 is $\pm 2\%$ over 6 s.

Note: You can find component dimensions and 3D/CAD data on the Internet at www.boschrexroth.com/tightening





Spindle bearing size 3 – components



| 1 Spindle bearing | Code | G1B102 | G2B152 | G1A102 | G1C102 | G2A152 | G2C152 |
|---|---------------------|------------|------------|---|------------|------------|------------|
|  | Order no. | 0608800063 | 0608800065 | 0608800062 | 0608800072 | 0608800064 | 0608800073 |
| | Max. torque | Nm 35 | 35 | 55 | 55 | 55 | 55 |
| | Range of spring | mm 25 | 50 | 25 | 25 | 50 | 50 |
| | Spring force | N 16–39 | 14–38 | 16–39 | 16–39 | 14–38 | 14–38 |
| | Reduction | 1 | 1 | 1 | 1 | 1 | 1 |
| | Avg. efficiency | 1 | 1 | 1 | 1 | 1 | 1 |
| | Length A | mm 102 | 152 | 102 | 102 | 152 | 152 |
| | Installation length | mm 112 | 162 | 112 | 112 | 162 | 162 |
| | Weight | kg 0.33 | 0.41 | 0.33 | 0.33 | 0.41 | 0.41 |
| 2 Measurement transducer | Code | 3DMC017 | 3DMC060 | | | | |
|  | Order no. | 0608820112 | 0608820113 | You can configure your tightening spindle with a redundant measurement transducer from the same type. Connect both measurement transducers with the redundant adapter. For measurement transducer cables, see page 140. | | | |
| | Nominal torque | Nm 17 | 60 | | | | |
| | Reduction | 1 | 1 | | | | |
| | Avg. efficiency | 1 | 1 | | | | |
| | Installation length | mm 118.6 | 118.6 | | | | |
| | Weight | kg 1 | 1 | | | | |
| 3 Redundant adapter | Code | 3AR | | | | | |
|  | Order no. | 0608810021 | | When configuring with a redundant measurement transducer, the adapter connects both measurement transducers. | | | |
| | Reduction | 1 | | | | | |
| | Avg. efficiency | 1 | | | | | |
| | Installation length | mm 57 | | | | | |
| | Weight | kg 0.4 | | | | | |
| 4 Adapter | Code | 3A | | | | | |
|  | Order no. | 0608810025 | | When configuring without a measurement transducer, the adapter connects the output drive and the planetary gearbox. | | | |
| | Reduction | 1 | | | | | |
| | Avg. efficiency | 1 | | | | | |
| | Installation length | mm 30.5 | | | | | |
| | Weight | kg 0.3 | | | | | |

| | | | | | |
|--|---------------------|--------------|--------------|--|--|
| 5 Planetary gearbox  | Code | 3GE27 | 3GE67 | | |
| | Order no. | 0608720053 | 0608720039 | | |
| | Reduction | 27 | 67.4 | | |
| | Avg. efficiency | 0.93 | 0.9 | | |
| | Installation length | mm | 65.5 | 81.5 | |
| | Weight | kg | 0.35 | 0.5 | |
| 6 Transverse gearbox  | Code | 3ULG | | | |
| | Order no. | 0608810037 | | The transverse gearbox shortens the length of your tightening spindle by the installation length of the EC motor plus the installation length of the transverse gearbox. | |
| | Reduction | 1 | | | |
| | Avg. efficiency | 0.95 | | | |
| | Installation length | mm | 30.1 | | |
| | Weight | kg | 0.4 | | |
| | | | | | |
| 7 EC motor  | Code | EC303 | | | |
| | Order no. | 0608701017 | | | |
| | Installation length | mm | 219 | | |
| | Weight | kg | 1.3 | | |

Side-by-side arrangement of tightening spindles (center-to-center distance)

| Number of tightening spindles | | 2 | 3 | 4 | 5 | 6 |
|---|------|---|---|---|---|---|
| | |  |  |  |  |  |
| Min. circle diameter- $\varnothing d_{min}$ mm | G... | 45 | 52 | 65 | 80 | 89 |

Tightening spindles size 3

Offset output drive



- ▶ Working range 1.7 – 53 Nm
- ▶ Max. output drive speed 740 rpm

Depending on the size, the actual components may differ from those in the illustration.

FEATURES

- ▶ For tight hole templates
- ▶ Standard tool mounts
- ▶ Maintenance-free for 1 million full-load cycles





| Tightening spindle | | Offset output drive | | | | Measure- ment transducer | Planetary gearbox | EC motor |
|--------------------|----------------------------|-----------------------------|--------------------------------------|----------|------------|--------------------------------|----------------------|---------------------|
| Working range | Max. output drive speed | Range of spring mm | Tool mount | Code | Order no. | Code/ Order no. | Code/ Order no. | Code/ Order no. |
| Nm | rpm | | | | | | | |
| 1.7*-15 | 740 | 50 | 1/4" quick-change chuck | VNS2B152 | 0608800630 | 3DMC017 0608820112 | 3GE27 0608720053 | EC303 0608701017 |
| | 295 | 50 | 1/4" quick-change chuck | VNS2B152 | 0608800630 | | 3GE67 0608720039 | |
| 6*-31 | 740 | 50 | 1/4" quick-change chuck | VNS2B152 | 0608800630 | 3DMC060 0608820113 | 3GE27 0608720053 | |
| 6*-33 | 295 | 50 | 1/4" quick-change chuck | VNS2B152 | 0608800630 | | 3GE67 0608720039 | |
| 1.7*-15 | 740 | 50 | 3/8" square drive | VNS2A152 | 0608800629 | 3DMC017 0608820112 | 3GE27 0608720053 | |
| | | | 3/8" square drive with centering pin | VNS2C152 | 0608800631 | | | |
| | 295 | 50 | 3/8" square drive | VNS2A152 | 0608800629 | | 3GE67 0608720039 | |
| | | | 3/8" square drive with centering pin | VNS2C152 | 0608800631 | | | |
| 6*-31 | 740 | 50 | 3/8" square drive | VNS2A152 | 0608800629 | 3DMC060 0608820113 | 3GE27 0608720053 | |
| | | | 3/8" square drive with centering pin | VNS2C152 | 0608800631 | | | |
| 6*-53 | 295 | 50 | 3/8" square drive | VNS2A152 | 0608800629 | | 3GE67 0608720039 | |
| | | | 3/8" square drive with centering pin | VNS2C152 | 0608800631 | | | |

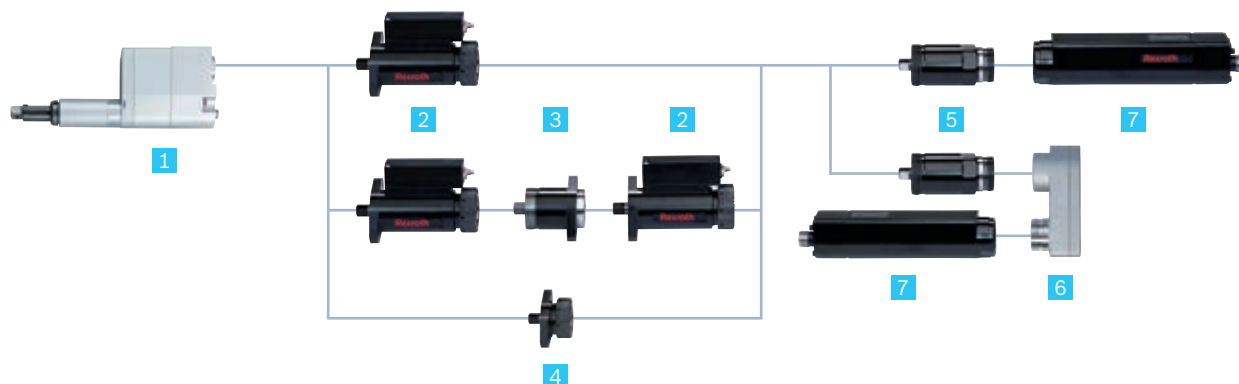

* Depending on the tolerance limits, position-based MCT required

Note: You can find component dimensions and 3D/CAD data on the Internet at www.boschrexroth.com/tightening





Offset output drive size 3 – components



| | | | | | |
|--|---------------------|-----|-----------------|-----------------|---|
| 1 Offset output drive  | Code | | VNS2B152 | VNS2A152 | VNS2C152 |
| | Order no. | | 0 608 800 630 | 0 608 800 629 | 0 608 800 631 |
| | Max. torque | Nm | 35 | 55 | 55 |
| | Range of spring | mm | 50 | 50 | 50 |
| | Spring force | N | 14–38 | 14–38 | 14–38 |
| | Reduction | | 1 | 1 | 1 |
| | Avg. efficiency | | 0.93 | 0.93 | 0.93 |
| | Length A | mm | 152 | 152 | 152 |
| | Installation length | mm | 240 | 240 | 240 |
| Weight | kg | 1.2 | 1.2 | 1.2 | |
| 2 Measurement transducer  | Code | | 3DMC017 | 3DMC060 | |
| | Order no. | | 0 608 820 112 | 0 608 820 113 | You can configure your tightening spindle with a redundant measurement transducer from the same type. Connect both measurement transducers with the redundant adapter. For measurement transducer cables, see page 140. |
| | Nominal torque | Nm | 17 | 60 | |
| | Reduction | | 1 | 1 | |
| | Avg. efficiency | | 1 | 1 | |
| | Installation length | mm | 118.6 | 118.6 | |
| Weight | kg | 1 | 1 | | |
| 3 Redundant adapter  | Code | | 3AR | | |
| | Order no. | | 0 608 810 021 | | When configuring with a redundant measurement transducer, the adapter connects both measurement transducers. |
| | Reduction | | 1 | | |
| | Avg. efficiency | | 1 | | |
| | Installation length | mm | 57 | | |
| Weight | kg | 0.4 | | | |
| 4 Adapter  | Code | | 3A | | |
| | Order no. | | 0 608 810 025 | | When configuring without a measurement transducer, the adapter connects the output drive and the planetary gearbox. |
| | Reduction | | 1 | | |
| | Avg. efficiency | | 1 | | |
| | Installation length | mm | 30.5 | | |
| Weight | kg | 0.3 | | | |

| | | | | |
|--|---------------------|--------------|--------------|--|
| 5 Planetary gearbox  | Code | 3GE27 | 3GE67 | |
| | Order no. | 0608720053 | 0608720039 | |
| | Reduction | 27 | 67.4 | |
| | Avg. efficiency | 0.93 | 0.9 | |
| | Installation length | mm | 65.5 | 81.5 |
| | Weight | kg | 0.35 | 0.5 |
| 6 Transverse gearbox  | Code | 3ULG | | |
| | Order no. | 0608810037 | | |
| | Reduction | 1 | | |
| | Avg. efficiency | 0.95 | | |
| | Installation length | mm | 30.1 | The transverse gearbox shortens the length of your tightening spindle by the installation length of the EC motor plus the installation length of the transverse gearbox. |
| | Weight | kg | 0.4 | |
| 7 EC motor  | Code | EC303 | | |
| | Order no. | 0608701017 | | |
| | Installation length | mm | 219 | |
| | Weight | kg | 1.3 | |

Side-by-side arrangement of tightening spindles (center-to-center distance)

| Number of tightening spindles | 2 | 3 | 4 | 5 | 6 |
|--|---|---|---|---|---|
| |  |  |  |  |  |
| Min. circle diameter- $\varnothing d_{\min}$ mm | VNS2...152 29 | 33.5 | 41 | 49.5 | 58 |

Tightening spindles size 3

Offset output drive with integrated measurement transducer



- ▶ Working range 3.2 – 57 Nm
- ▶ Max. output drive speed 740 rpm

Depending on the size, the actual components may differ from those in the illustration.

FEATURES

- ▶ Reduced center-to-center distances
- ▶ Torque measurement directly at the bolt
- ▶ Proximity switching digital measurement transfer
- ▶ Efficiency fluctuations do not affect measurements



| Tightening spindle | | Offset output drive with integrated measurement transducer | | | | Planetary gearbox | EC motor |
|--------------------|-------------------------------|--|-------------------|---------|--------------|---------------------|---------------------|
| Working range Nm | Max. output drive speed 1/min | Range of spring mm | Tool mount | Code | Order no. | Code/ Order no. | Code/ Order no. |
| 3.2*-16 | 740 | 50 | 3/8" square drive | 3VMC017 | 0 608801 009 | 3GE27 0608720053 | EC303 0608701017 |
| | 295 | 50 | 3/8" square drive | 3VMC017 | 0 608801 009 | 3GE67 0608720039 | |
| 6*-31 | 740 | 50 | 3/8" square drive | 3VMC035 | 0 608801 010 | 3GE27 0608720053 | |
| 6*-33 | 295 | 50 | 3/8" square drive | 3VMC035 | 0 608801 010 | 3GE67 | |
| 10*-57 | 295 | 50 | 3/8" square drive | 3VMC060 | 0 608801 011 | 0608720039 | |

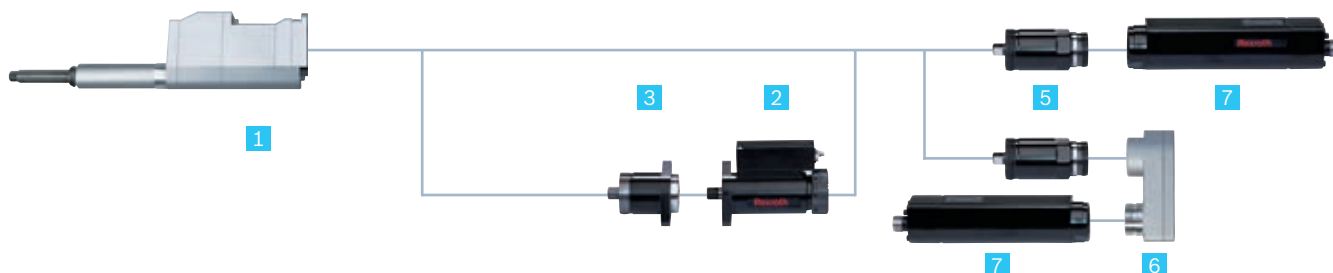

* Depending on the tolerance limits, position-based MCT required

Note: You can find component dimensions and 3D/CAD data on the Internet at www.boschrexroth.com/tightening





Offset output drive with integrated measurement transducer size 3 – components



| | | | | | |
|--|---------------------|----|----------------|----------------|---|
| 1 Offset output drive with integrated measurement transducer  | Code | | 3VMC017 | 3VMC035 | 3VMC060 |
| | Order no. | | 0 608 801 009 | 0 608 801 010 | 0 608 801 011 |
| | Max. torque | Nm | 17 | 35 | 60 |
| | Range of spring | mm | 50 | 50 | 50 |
| | Spring force | N | 14–38 | 14–38 | 14–38 |
| | Reduction | | 1 | 1 | 1 |
| | Avg. efficiency | | 0.93 | 0.93 | 0.93 |
| | Length A | mm | 152 | 152 | 152 |
| | Installation length | mm | 311 | 311 | 311 |
| | Weight | kg | 3.4 | 3.4 | 3.4 |
| 2 Measurement transducer  | Code | | 3DMC017 | 3DMC060 | |
| | Order no. | | 0 608 820 112 | 0 608 820 113 | You can configure your tightening spindle with a redundant measurement transducer from the same type. Connect both measurement transducers with the redundant adapter. For measurement transducer cables, see page 140. |
| | Nominal torque | Nm | 17 | 60 | |
| | Reduction | | 1 | 1 | |
| | Avg. efficiency | | 1 | 1 | |
| | Installation length | mm | 118.6 | 118.6 | |
| Weight | kg | 1 | 1 | | |
| 3 Redundant adapter  | Code | | 3AR | | |
| | Order no. | | 0 608 810 021 | | When configuring with a redundant measurement transducer, the adapter connects both measurement transducers. |
| | Reduction | | 1 | | |
| | Avg. efficiency | | 1 | | |
| | Installation length | mm | 57 | | |
| | Weight | kg | 0.4 | | |

| | | | | |
|--|---------------------|--------------|--------------|--|
| 5 Planetary gearbox  | Code | 3GE27 | 3GE67 | |
| | Order no. | 0608720053 | 0608720039 | |
| | Reduction | 27 | 67.4 | |
| | Avg. efficiency | 0.93 | 0.9 | |
| | Installation length | mm | 65.5 | 81.5 |
| | Weight | kg | 0.35 | 0.5 |
| 6 Transverse gearbox  | Code | 3ULG | | |
| | Order no. | 0608810037 | | |
| | Reduction | 1 | | |
| | Avg. efficiency | 0.95 | | |
| | Installation length | mm | 30.1 | The transverse gearbox shortens the length of your tightening spindle by the installation length of the EC motor plus the installation length of the transverse gearbox. |
| | Weight | kg | 0.4 | |
| 7 EC motor  | Code | EC303 | | |
| | Order no. | 0608701017 | | |
| | Installation length | mm | 219 | |
| | Weight | kg | 1.3 | |

Side-by-side arrangement of tightening spindles (center-to-center distance)

| Number of tightening spindles | 2 | 3 | 4 | 5 | 6 | |
|---|---|---|---|---|---|----|
| |  |  |  |  |  | |
| Min. circle diameter- $\varnothing d_{min}$ mm | 3VMC... | 31 | 36 | 44 | 53 | 62 |

Tightening spindles size 3 Angle head



- ▶ Working range 5.4 – 90 Nm
- ▶ Max. output drive speed 705 rpm

Depending on the size, the actual components may differ from those in the illustration.

FEATURES

- ▶ For restricted accessibility
- ▶ Precision tothing for high torque accuracy
- ▶ Incremental positioning (9° increments)
- ▶ Integrated fastening flanges
- ▶ With integrated measurement transducer on request

| Tightening spindle | | Angle head | | | Measurement transducer | Planetary gearbox | EC motor |
|--------------------|-----------------------------|-------------------|-------|------------|------------------------|---------------------|---------------------|
| Working range Nm | Max. output drive speed rpm | Tool mount | Code | Order no. | Code / Order no. | Code / Order no. | Code / Order no. |
| 5.4–16 | 705 | 3/8" square drive | 3W027 | 0608810042 | 3DMC017 0608820112 | 3GE27 0608720053 | EC303 0608701017 |
| | 280 | 3/8" square drive | 3W027 | 0608810042 | | 3GE67 0608720039 | |
| 5.7–27 | 705 | 3/8" square drive | 3W027 | 0608810042 | 3DMC060 0608820113 | 3GE27 0608720053 | |
| | 280 | 3/8" square drive | 3W027 | 0608810042 | | 3GE67 0608720039 | |
| 10–33 | 705 | 3/8" square drive | 3W050 | 0608810043 | | 3GE27 0608720053 | |
| 10–50 | 280 | 3/8" square drive | 3W050 | 0608810043 | | 3GE67 0608720039 | |
| 18–53 | 440 | 1/2" square drive | 3W090 | 0608810044 | | 3GE27 0608720053 | |
| 18–90 | 175 | 1/2" square drive | 3W090 | 0608810044 | | 3GE67 0608720039 | |

Note: To ensure troublefree operation, the angle head must always be operated with an output drive axial compensator, e.g. spindle bearing. See page 21.

For an output drive axial compensator, the following angle head/spindle bearing combinations are possible:

3W027 (0608810042) – spindle bearing size 3 (page 30)





3W050 (0608810043) – spindle bearing size 3 (page 30)

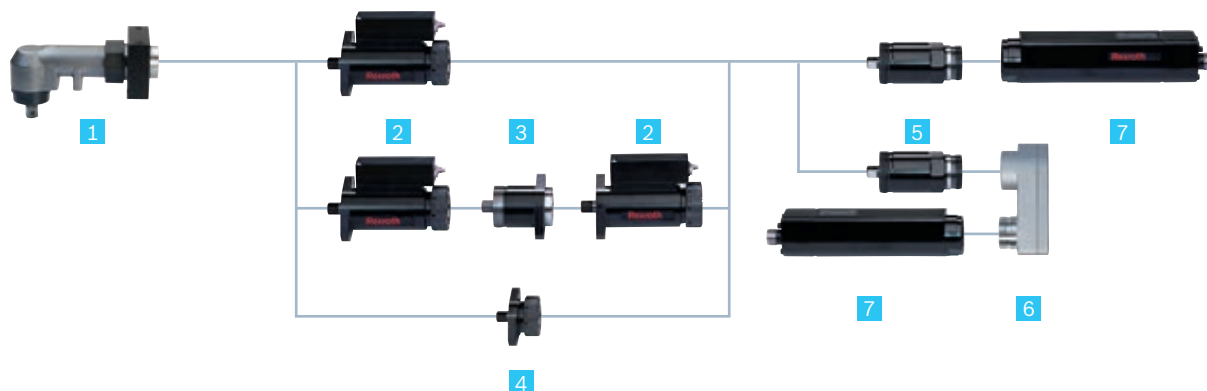

3W090 (0608810044) – spindle bearing size 4 (page 50)





Note: You can find component dimensions and 3D/CAD data on the Internet at www.boschrexroth.com/tightening

Angle head size 3 – components



| | | | | | |
|--|---------------------|-----|----------------|----------------|---|
| 1 Angle head  | Code | | 3W027 | 3W050 | 3W090 |
| | Order no. | | 0 608 810 042 | 0 608 810 043 | 0 608 810 044 |
| | Max. torque | Nm | 27 | 50 | 90 |
| | Reduction | | 1.05 | 1.05 | 1.67 |
| | Avg. efficiency | | 0.95 | 0.95 | 0.95 |
| | Installation length | mm | 85.6 | 125.6 | 125.6 |
| | Weight | kg | 1 | 1.42 | 1.7 |
| 2 Measurement transducer  | Code | | 3DMC017 | 3DMC060 | |
| | Order no. | | 0 608 820 112 | 0 608 820 113 | You can configure your tightening spindle with a redundant measurement transducer from the same type. Connect both measurement transducers with the redundant adapter. For measurement transducer cables, see page 140. |
| | Nominal torque | Nm | 17 | 60 | |
| | Reduction | | 1 | 1 | |
| | Avg. efficiency | | 1 | 1 | |
| | Installation length | mm | 118.6 | 118.6 | |
| Weight | kg | 1 | 1 | | |
| 3 Redundant adapter  | Code | | 3AR | | When configuring with a redundant measurement transducer, the adapter connects both measurement transducers. |
| | Order no. | | 0 608 810 021 | | |
| | Reduction | | 1 | | |
| | Avg. efficiency | | 1 | | |
| | Installation length | mm | 57 | | |
| Weight | kg | 0.4 | | | |
| 4 Adapter  | Code | | 3A | | When configuring without a measurement transducer, the adapter connects the output drive and the planetary gearbox. |
| | Order no. | | 0 608 810 025 | | |
| | Reduction | | 1 | | |
| | Avg. efficiency | | 1 | | |
| | Installation length | mm | 30.5 | | |
| Weight | kg | 0.3 | | | |

| | | | | | |
|--|-----------------------------|---------------------|--------------|--------------|------|
|  | 5 Planetary gearbox | Code | 3GE27 | 3GE67 | |
| | | Order no. | 0608720053 | 0608720039 | |
| | | Reduction | 27 | 67.4 | |
| | | Avg. efficiency | 0.93 | 0.9 | |
| | | Installation length | mm | 65.5 | 81.5 |
| | | Weight | kg | 0.35 | 0.5 |
|  | 6 Transverse gearbox | Code | 3ULG | | |
| | | Order no. | 0608810037 | | |
| | | Reduction | 1 | | |
| | | Avg. efficiency | 0.95 | | |
| | | Installation length | mm | 30.1 | |
| | | Weight | kg | 0.4 | |
| The transverse gearbox shortens the length of your tightening spindle by the installation length of the EC motor plus the installation length of the transverse gearbox. | | | | | |
|  | 7 EC motor | Code | EC303 | | |
| | | Order no. | 0608701017 | | |
| | | Installation length | mm | 219 | |
| | | Weight | kg | 1.3 | |

| Side-by-side arrangement of tightening spindles (center-to-center distance) | | | | | | |
|---|-------|---|---|---|---|---|
| Number of tightening spindles | | 2 | 3 | 4 | 5 | 6 |
| | |  |  |  |  |  |
| Min. circle diameter- \varnothing d _{min} mm | 3W027 | 29 | 34 | 41 | 50 | 58 |
| | 3W050 | 35 | 40 | 50 | 60 | 70 |
| | 3W090 | 45 | 52 | 64 | 78 | 90 |

Tightening spindles size 3

Feed output drive



- ▶ Working range 1.7 – 53 Nm
- ▶ Max. output drive speed 740 rpm

Depending on the size, the actual components may differ from those in the illustration.

FEATURES

- ▶ Integrated feed movement
- ▶ In connection with automatic bolt supply
- ▶ Standard tool mounts and compressed air connections
- ▶ Maintenance-free for 1 million full-load cycles





| Tightening spindle | | Feed output drive | | | | Measurement transducer | Planetary gearbox | EC motor |
|---------------------|--------------------------------|-------------------|-------------------|-------|---------------|------------------------|---------------------|---------------------|
| Working range Nm | Max. output drive speed rpm | Stroke mm | Tool mount | Code | Order no. | Code/ Order no. | Code/ Order no. | Code/ Order no. |
| 1.7*-15 | 740 | 200 | 3/8" square drive | 3S1M8 | 0 608 800 648 | 3DMC017 0608820112 | 3GE27 0608720053 | EC303 0608701017 |
| | 295 | 200 | 3/8" square drive | 3S1M8 | 0 608 800 648 | | 3GE67 0608720039 | |
| 1.7*-15 | 740 | 200 | 1/4" square drive | 3S2M8 | 0 608 800 649 | | 3GE27 0608720053 | |
| | 295 | 200 | 1/4" square drive | 3S2M8 | 0 608 800 649 | | 3GE67 0608720039 | |
| 5.3*-20 | 295 | 200 | 1/4" square drive | 3S2M8 | 0 608 800 649 | 3DMC060 0608820113 | 3GE67 0608720039 | |
| | 740 | 200 | 1/4" square drive | 3S2M8 | 0 608 800 649 | | 3GE27 0608720053 | |
| 7*-31 | 740 | 200 | 3/8" square drive | 3S1M8 | 0 608 800 648 | | 3GE27 0608720053 | |
| 6*-53 | 295 | 200 | 3/8" square drive | 3S1M8 | 0 608 800 648 | | 3GE67 0608720039 | |

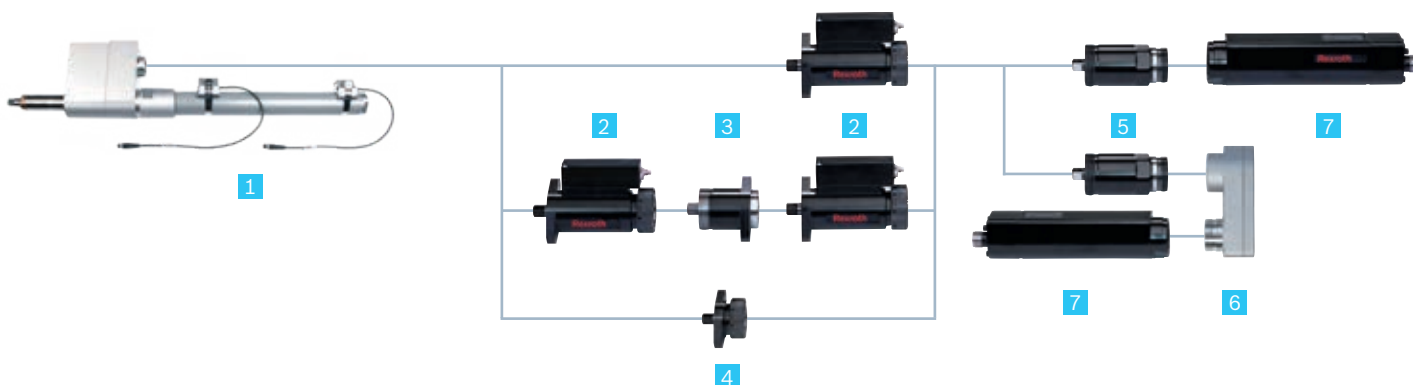

* Depending on the tolerance limits, position-based MCT required





Note: You can find component dimensions and 3D/CAD data on the Internet at www.boschrexroth.com/tightening

Feed output drive size 3 – components



| 1 Feed output drive | Code | 3S2M8 | 3S1M8 | |
|---|---------------------|---------------|---------------|---|
|  | Order no. | 0 608 800 649 | 0 608 800 648 | |
| | Max. torque | Nm 20 | 55 | |
| | Stroke | mm 200 | 200 | |
| | Max. air pressure | bar 4 | 4 | |
| | Reduction | 1 | 1 | |
| | Avg. efficiency | 0.93 | 0.93 | |
| | Length A | mm 97 | 97 | |
| | Installation length | mm 204 | 204 | |
| | Weight | kg 3.5 | 3.5 | |
| 2 Measurement transducer | Code | 3DMC017 | 3DMC060 | |
|  | Order no. | 0608820112 | 0 608 820 113 | You can configure your tightening spindle with a redundant measurement transducer from the same type. Connect both measurement transducers with the redundant adapter. For measurement transducer cables, see page 140. |
| | Nominal torque | Nm 17 | 60 | |
| | Reduction | 1 | 1 | |
| | Avg. efficiency | 1 | 1 | |
| | Installation length | mm 118.6 | 118.6 | |
| | Weight | kg 1 | 1 | |
| 3 Redundant adapter | Code | 3AR | | |
|  | Order no. | 0 608 810 021 | | When configuring with a redundant measurement transducer, the adapter connects both measurement transducers. |
| | Reduction | 1 | | |
| | Avg. efficiency | 1 | | |
| | Installation length | mm 57 | | |
| | Weight | kg 0.4 | | |
| 4 Adapter | Code | 3A | | |
|  | Order no. | 0 608 810 025 | | When configuring without a measurement transducer, the adapter connects the output drive and the planetary gearbox. |
| | Reduction | 1 | | |
| | Avg. efficiency | 1 | | |
| | Installation length | mm 30.5 | | |
| | Weight | kg 0.3 | | |

| | | | | | |
|--|-----------------------------|---------------------|--------------|--------------|------|
|  | 5 Planetary gearbox | Code | 3GE27 | 3GE67 | |
| | | Order no. | 0608720053 | 0608720039 | |
| | | Reduction | 27 | 67.4 | |
| | | Avg. efficiency | 0.93 | 0.9 | |
| | | Installation length | mm | 65.5 | 81.5 |
| | | Weight | kg | 0.35 | 0.5 |
|  | 6 Transverse gearbox | Code | 3ULG | | |
| | | Order no. | 0608810037 | | |
| | | Reduction | 1 | | |
| | | Avg. efficiency | 0.95 | | |
| | | Installation length | mm | 30.1 | |
| | | Weight | kg | 0.4 | |
| The transverse gearbox shortens the length of your tightening spindle by the installation length of the EC motor plus the installation length of the transverse gearbox. | | | | | |
|  | 7 EC motor | Code | EC303 | | |
| | | Order no. | 0608701017 | | |
| | | Installation length | mm | 219 | |
| | | Weight | kg | 1.3 | |

| Side-by-side arrangement of tightening spindles (center-to-center distance) | | | | | | |
|--|-------|---|---|---|---|---|
| Number of tightening spindles | | 2 | 3 | 4 | 5 | 6 |
| | |  |  |  |  |  |
| Min. circle diameter- $\varnothing d_{\min}$ mm | 3S... | 49 | 56.5 | 69.5 | 83.5 | 98 |

Tightening spindles size 4

Spindle bearing



- ▶ Working range 5.7 – 150 Nm
- ▶ Max. output drive speed 1,000 rpm

Depending on the size, the actual components may differ from those in the illustration.

FEATURES

- ▶ Various lengths with axial compensator
- ▶ Standard tool mounts
- ▶ Maximum efficiency
- ▶ Maintenance-free for 1 million full-load cycles





| Tightening spindle | | Spindle bearing | | | | Measurement transducer | Planetary gearbox | EC motor | | | | | |
|--------------------|--------------------------------------|---|--------------------------------------|-------------|--------------------------------------|--------------------------|------------------------|--------------------------|------------------------|---------------|--------------------------|------------------------|--|
| Working range* | Max. output drive speed | Range of spring mm / Max. Spring force N | Tool mount | Code | Order no. | Code / Order no. | Code / Order no. | Code / Order no. | | | | | |
| Nm | rpm | | | | | | | | | | | | |
| 5.7–56 | 340 | 25 / 93.3 | 1/2" square drive | GK1A156 | 0 608 800 031 | 4DMC060 0 608 820 114 | 4GE59 0 608 720 040 | EC304 0 608 701 018 | | | | | |
| | | | 7/16" quick-change chuck | GK1B156 | 0 608 800 020 | | | | | | | | |
| | | | 1/2" square drive with centering pin | GK1C156 | 0 608 800 001 | | | | | | | | |
| | | 50 / 93.3 | 1/2" square drive | GK2A181/251 | 0 608 800 006 / 048 | | | | | | | | |
| | | | 7/16" quick-change chuck | GK2B181/251 | 0 608 800 008 / 049 | | | | | | | | |
| | | | 1/2" square drive with centering pin | GK2C181/251 | 0 608 800 021 / 050 | | | | | | | | |
| | | | 1/2" square drive | GL2A319 | 0 608 800 056 | | | | | | | | |
| | | | 7/16" quick-change chuck | GL2B319 | 0 608 800 057 | | | | | | | | |
| | | | 1/2" square drive with centering pin | GL2C319 | 0 608 800 027 | | | | | | | | |
| | | 5.7–54 | 1,000 | 25 / 90.2 | 1/2" square drive | | | | GK1A156 | 0 608 800 031 | 4DMC060 0 608 820 114 | 4GE19 0 608 720 056 | |
| | | | | | 7/16" quick-change chuck | | | | GK1B156 | 0 608 800 020 | | | |
| | | | | | 1/2" square drive with centering pin | | | | GK1C156 | 0 608 800 001 | | | |
| 50 / 93.3 | 1/2" square drive | | | GK2A181/251 | 0 608 800 006 / 048 | | | | | | | | |
| | 7/16" quick-change chuck | | | GK2B181/251 | 0 608 800 008 / 049 | | | | | | | | |
| | 1/2" square drive with centering pin | | | GK2C181/251 | 0 608 800 021 / 050 | | | | | | | | |
| | 1/2" square drive | | | GL2A319 | 0 608 800 056 | | | | | | | | |
| | 7/16" quick-change chuck | | | GL2B319 | 0 608 800 057 | | | | | | | | |
| | 1/2" square drive with centering pin | | | GL2C319 | 0 608 800 027 | | | | | | | | |
| 15–150 | 340 | | | 25 / 93.3 | 1/2" square drive | GK1A156 | 0 608 800 031 | 4DMC160 0 608 820 115 | 4GE59 0 608 720 040 | | | | |
| | | | | | 7/16" quick-change chuck | GK1B156 | 0 608 800 020 | | | | | | |
| | | | | | 1/2" square drive with centering pin | GK1C156 | 0 608 800 001 | | | | | | |
| | | 50 / 93.3 | 1/2" square drive | GK2A181/251 | 0 608 800 006 / 048 | | | | | | | | |
| | | | 7/16" quick-change chuck | GK2B181/251 | 0 608 800 008 / 049 | | | | | | | | |
| | | | 1/2" square drive with centering pin | GK2C181/251 | 0 608 800 021 / 050 | | | | | | | | |
| | | | 1/2" square drive | GL2A319 | 0 608 800 056 | | | | | | | | |
| | | | 7/16" quick-change chuck | GL2B319 | 0 608 800 057 | | | | | | | | |
| | | | 1/2" square drive with centering pin | GL2C319 | 0 608 800 027 | | | | | | | | |

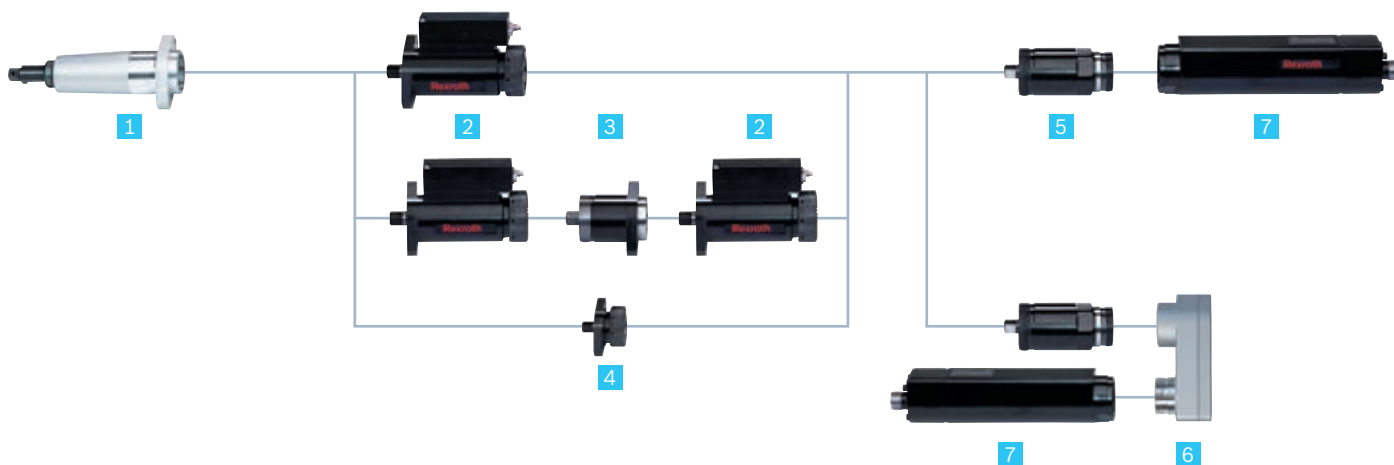

* The accuracy within the working range according to VDI/VDE 2647 is $\pm 2\%$ (6 s).

Note: You can find component dimensions and 3D/CAD data on the Internet at www.boschrexroth.com/tightening





Spindle bearing size 4 – components

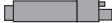

| | | | | | | | | |
|--|-----------------------|----------------|----------------|----------------|----------------|----------------|----------------|-------|
| 1 Spindle bearing  | Code | GK1A156 | GK1B156 | GK1C156 | GK2A181 | GK2B181 | GK2C181 | |
| | Order no. | 0608800031 | 0608800020 | 0608800001 | 0608800006 | 0608800008 | 0608800021 | |
| | Max. torque | Nm | 150 | 150 | 150 | 150 | 150 | 150 |
| | Range of spring | mm | 25 | 25 | 25 | 50 | 50 | 50 |
| | Spring force | N | 39–90 | 39–90 | 39–90 | 30–93 | 30–93 | 30–93 |
| | Reduction | | 1 | 1 | 1 | 1 | 1 | 1 |
| | Avg. efficiency | | 1 | 1 | 1 | 1 | 1 | 1 |
| | Length A | mm | 156 | 156 | 156 | 181 | 181 | 181 |
| Installation length | mm | 170 | 170 | 170 | 195 | 195 | 195 | |
| Weight | kg | 0.9 | 0.9 | 0.9 | 1 | 1 | 1 | |
| 1 Spindle bearing  | Code | GK2A251 | GK2B251 | GK2C251 | GL2A319 | GL2B319 | GL2C319 | |
| | Order no. | 0608800048 | 0608800049 | 0608800050 | 0608800056 | 0608800057 | 0608800027 | |
| | Max. torque | Nm | 150 | 150 | 150 | 150 | 150 | 150 |
| | Range of spring | mm | 50 | 50 | 50 | 50 | 50 | 50 |
| | Spring force | N | 30–93 | 30–93 | 30–93 | 30–93 | 30–93 | 30–93 |
| | Reduction | | 1 | 1 | 1 | 1 | 1 | 1 |
| | Avg. efficiency | | 1 | 1 | 1 | 1 | 1 | 1 |
| | Length A | mm | 251 | 251 | 251 | 319 | 319 | 319 |
| Installation length | mm | 265 | 265 | 265 | 333 | 333 | 333 | |
| Weight | kg | 1 | 1 | 1 | 2.1 | 2.1 | 2.1 | |
| 2 Measurement transducer  | Code | 4DMC060 | 4DMC160 | | | | | |
| | Order no. | 0608820114 | 0608820115 | | | | | |
| | Max. torque | Nm | 60 | 160 | | | | |
| | Reduction | | 1 | 1 | | | | |
| | Avg. efficiency | | 1 | 1 | | | | |
| | Length | mm | 182 | 182 | | | | |
| | Installation length A | mm | 122 | 122 | | | | |
| Weight | kg | 1.6 | 1.6 | | | | | |
| 3 Redundant adapter  | Code | 4AR | | | | | | |
| | Order no. | 0608810022 | | | | | | |
| | Reduction | | 1 | | | | | |
| | Avg. efficiency | | 1 | | | | | |
| | Installation length | mm | 65 | | | | | |
| Weight | kg | 0.8 | | | | | | |

| | | | | |
|--|---------------------|---------------|---------------|--|
| 4 Adapter  | Code | 4A | | When configuring without a measurement transducer, the adapter connects the output drive and the planetary gearbox. |
| | Order no. | 0 608 810 026 | | |
| | Reduction | 1 | | |
| | Avg. efficiency | 1 | | |
| | Installation length | mm | 26.5 | |
| Weight | kg | 0.4 | | |
| 5 Planetary gearbox  | Code | 4GE19 | 4GE59 | |
| | Order no. | 0 608 720 056 | 0 608 720 040 | |
| | Reduction | 19.3 | 58.6 | |
| | Avg. efficiency | 0.93 | 0.9 | |
| | Installation length | mm | 82.9 | 105.5 |
| Weight | kg | 0.7 | 1.1 | |
| 6 Transverse gearbox  | Code | 4ULG | | The transverse gearbox shortens the length of your tightening spindle by the installation length of the EC motor plus the installation length of the transverse gearbox. |
| | Order no. | 0 608 810 038 | | |
| | Reduction | 1 | | |
| | Avg. efficiency | 0.95 | | |
| | Installation length | mm | 41.3 | |
| Weight | kg | 1.3 | | |
| 7 EC motor  | Code | EC304 | | |
| | Order no. | 0 608 701 018 | | |
| | Installation length | mm | 247 | |
| | Weight | kg | 2.7 | |

Side-by-side arrangement of tightening spindles (center-to-center distance)

| Number of tightening spindles | 2 | 3 | 4 | 5 | 6 |
|---|---|---|---|---|---|
| |  |  |  |  |  |
| Min. circle diameter- $\varnothing d_{min}$ mm | G... | 59 | 69 | 89 | 109 |

Tightening spindles size 4

Offset output drive



- ▶ Working range 6 – 340 Nm
- ▶ Max. output drive speed 1,000 rpm

Depending on the size, the actual components may differ from those in the illustration.

FEATURES

- ▶ For tight hole templates, side-by-side arrangement with small center-to-center distances
- ▶ Standard tool mounts
- ▶ Maintenance-free for 1 million full-load cycles





| Tightening spindle | | Offset output drive | | | | Measurement transducer | Planetary gearbox | EC motor |
|--------------------|-----------------------------|---------------------|--------------------------------------|--------------|---------------------|--------------------------|------------------------|------------------------|
| Working range | Max. output drive speed rpm | Range of spring | Tool mount | Code | Order no. | Code/Order no. | Code/Order no. | Code/Order no. |
| Nm | | mm | | | | | | |
| 6*-49 | 1,000 | 50 | 1/2" square drive | VNK2A181/251 | 0 608 800 632 / 633 | 4DMC060 0 608 820 114 | 4GE19 0 608 720 056 | EC304 0 608 701 018 |
| | | | 7/16" change chuck | VNK2B181/251 | 0 608 800 634 / 635 | | | |
| | | | 1/2" square drive with centering pin | VNK2C181/251 | 0 608 800 636 / 637 | | | |
| | | | 1/2" square drive | VNL2A319 | 0 608 800 639 | | | |
| | | | 1/2" square drive with centering pin | VNL2C319 | 0 608 800 643 | | | |
| 8*-73 | 740 | 50 | 3/4" square drive | VUK2D242 | 0 608 PE0 588 | | | |
| 13*-128 | 410 | 50 | 3/4" square drive | VUK2D186 | 0 608 800 644 | | | |
| | | | | VUL2D290 | 0 608 800 645 | | | |
| 15*-138 | 340 | 50 | 1/2" square drive | VNK2A181/251 | 0 608 800 632 / 633 | 4DMC160 0 608 820 115 | 4GE59 0 608 720 040 | |
| | | | 7/16" quick-change chuck | VNK2B181/251 | 0 608 800 634 / 635 | | | |
| | | | 1/2" square drive with centering pin | VNK2C181/251 | 0 608 800 636 / 637 | | | |
| | | | 1/2" square drive | VNL2A319 | 0 608 800 639 | | | |
| | | | 1/2" square drive with centering pin | VNL2C319 | 0 608 800 643 | | | |
| 20*-200 | 240 | 50 | 3/4" square drive | VUK2D242 | 0 608 PE0 588 | | | |
| 35*-340 | 135 | 50 | 3/4" square drive | VUK2D186 | 0 608 800 644 | | | |
| | | | | VUL2D290 | 0 608 800 645 | | | |



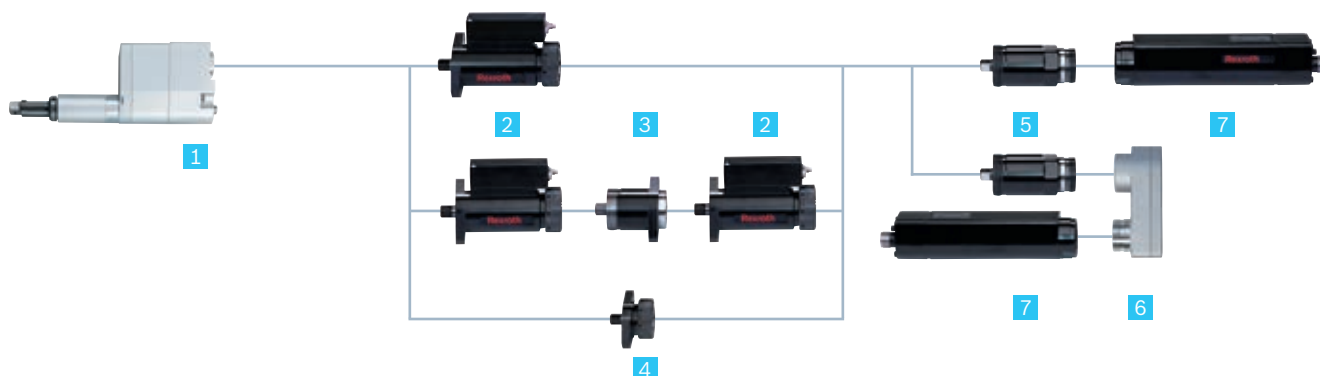

* Depending on the tolerance limits, position-based MCT required

Note: You can find component dimensions and 3D/CAD data on the Internet at www.boschrexroth.com/tightening





Offset output drive size 4 – components



| | | | | | | | | |
|--|-----------------------|-----|-----------------|-----------------|-----------------|-----------------|-----------------|-----------------|
| 1 Offset output drive  | Code | | VNK2A181 | VNK2B181 | VNK2C181 | VNK2A251 | VNK2B251 | VNK2C251 |
| | Order no. | | 0608800632 | 0608800634 | 0608800636 | 0608800633 | 0608800635 | 0608800637 |
| | Max. torque | Nm | 150 | 150 | 150 | 150 | 150 | 150 |
| | Range of spring | mm | 50 | 50 | 50 | 50 | 50 | 50 |
| | Spring force | N | 30–93 | 30–93 | 30–93 | 30–93 | 30–93 | 30–93 |
| | Reduction | | 1 | 1 | 1 | 1 | 1 | 1 |
| | Avg. efficiency | | 0.91 | 0.91 | 0.91 | 0.91 | 0.91 | 0.91 |
| | Length A | mm | 182 | 182 | 182 | 252 | 252 | 252 |
| | Installation length | mm | 309 | 309 | 309 | 379 | 379 | 379 |
| Weight | kg | 3.4 | 3.4 | 3.4 | 4.0 | 4.0 | 4.0 | |
| 1 Offset output drive  | Code | | VNL2A319 | VNL2C319 | VUK2D242 | VUK2D186 | VUL2D290 | |
| | Order no. | | 0608800639 | 0608800643 | 0608PE0588 | 0608800644 | 0608800645 | |
| | Max. torque | Nm | 150 | 150 | 200 | 340 | 340 | |
| | Range of spring | mm | 50 | 50 | 50 | 50 | 50 | |
| | Spring force | N | 30–93 | 30–93 | 30–93 | 30–93 | 30–93 | |
| | Reduction | | 1 | 1 | 1.46 | 2.56 | 2.56 | |
| | Avg. efficiency | | 0.91 | 0.91 | 0.92 | 0.92 | 0.92 | |
| | Length A | mm | 182 | 182 | 242 | 252 | 252 | |
| | Installation length | mm | 448 | 448 | 370 | 354 | 458 | |
| Weight | kg | 4.5 | 4.5 | 5.8 | 7.7 | 8.5 | | |
| 2 Measurement transducer  | Code | | 4DMC060 | 4DMC160 | | | | |
| | Order no. | | 0608820114 | 0608820115 | | | | |
| | Max. torque | Nm | 60 | 160 | | | | |
| | Reduction | | 1 | 1 | | | | |
| | Avg. efficiency | | 1 | 1 | | | | |
| | Length | mm | 182 | 182 | | | | |
| | Installation length A | mm | 122 | 122 | | | | |
| Weight | kg | 1.6 | 1.6 | | | | | |
| 3 Redundant adapter  | Code | | 4AR | | | | | |
| | Order no. | | 0608810022 | | | | | |
| | Reduction | | 1 | | | | | |
| | Avg. efficiency | | 1 | | | | | |
| | Installation length | mm | 65 | | | | | |
| Weight | kg | 0.8 | | | | | | |

| | | | | |
|--|---------------------|---------------|---------------|--|
| 4 Adapter  | Code | 4A | | When configuring without a measurement transducer, the adapter connects the output drive and the planetary gearbox. |
| | Order no. | 0 608 810 026 | | |
| | Reduction | 1 | | |
| | Avg. efficiency | 1 | | |
| | Installation length | mm | 26.5 | |
| Weight | kg | 0.4 | | |
| 5 Planetary gearbox  | Code | 4GE19 | 4GE59 | |
| | Order no. | 0 608 720 056 | 0 608 720 040 | |
| | Reduction | 19.3 | 58.6 | |
| | Avg. efficiency | 0.93 | 0.9 | |
| | Installation length | mm | 82.9 | 105.5 |
| Weight | kg | 0.7 | 1.1 | |
| 6 Transverse gearbox  | Code | 4ULG | | The transverse gearbox shortens the length of your tightening spindle by the installation length of the EC motor plus the installation length of the transverse gearbox. |
| | Order no. | 0 608 810 038 | | |
| | Reduction | 1 | | |
| | Avg. efficiency | 0.95 | | |
| | Installation length | mm | 41.3 | |
| Weight | kg | 1.3 | | |
| 7 EC motor  | Code | EC304 | | |
| | Order no. | 0 608 701 018 | | |
| | Installation length | mm | 247 | |
| | Weight | kg | 2.7 | |

Side-by-side arrangement of tightening spindles (center-to-center distance)

| Number of tightening spindles | | 2 | 3 | 4 | 5 | 6 |
|---|----------|---|---|---|---|---|
| | |  |  |  |  |  |
| Min. circle diameter- \varnothing d_{min} mm | VN... | 44 | 51 | 63 | 75 | 88 |
| | VU... | 57 | 66 | 81 | 97 | 114 |
| | VUK2D242 | 48 | 56 | 68 | 82 | 96 |

Tightening spindles size 4

Offset output drive with integrated measurement transducer



- ▶ Working range 15 – 342 Nm
- ▶ Max. output drive speed 1,000 rpm

Depending on the size, the actual components may differ from those in the illustration.

FEATURES

- ▶ Reduced center-to-center distances
- ▶ Torque measurement directly at the bolt
- ▶ Proximity switching digital measurement transfer
- ▶ Efficiency fluctuations do not affect measurements





| Tightening spindle | | Offset output drive with integrated measurement transducer | | | | Planetary gearbox | EC motor |
|--------------------|-------------------------|--|-------------------|---------|------------|--------------------|--------------------|
| Working range | Max. output drive speed | Range of spring | Tool mount | Code | Order no. | Code/ Order no. | Code/ Order no. |
| Nm | rpm | mm | | | | | |
| 15*-49 | 1,000 | 80 | 1/2" square drive | 4VMC150 | 0608801004 | 4GE19 | EC304 |
| 21*-73 | 700 | 80 | 3/4" square drive | 4VMC210 | 0608801005 | 0608720056 | 0608701018 |
| 36*-128 | 410 | 80 | 3/4" square drive | 4VMC360 | 0608801006 | | |
| 15*-142 | 340 | 80 | 1/2" square drive | 4VMC150 | 0608801004 | 4GE59 | |
| 21*-200 | 240 | 80 | 3/4" square drive | 4VMC210 | 0608801005 | 0608720040 | |
| 36*-342 | 135 | 80 | 3/4" square drive | 4VMC360 | 0608801006 | | |

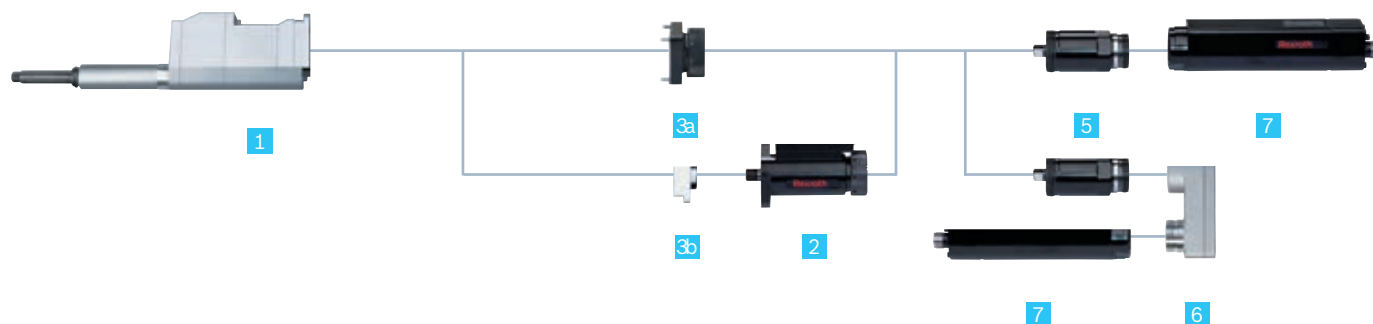

* Depending on the tolerance limits, position-based MCT required

Note: You can find component dimensions and 3D/CAD data on the Internet at www.boschrexroth.com/tightening





Offset output drive with integrated measurement transducer size 4 – components



| | | | | | |
|--|---------------------|----------------|----------------|---|--------|
| 1 Offset output drive with integrated measurement transducer  | Code | 4VMC150 | 4VMC210 | 4VMC360 | |
| | Order no. | 0 608 801 004 | 0 608 801 005 | 0 608 801 006 | |
| | Max. torque | Nm | 150 | 210 | 360 |
| | Range of spring | mm | 80 | 80 | 80 |
| | Spring force | N | 30–100 | 30–100 | 30–100 |
| | Reduction | | 1 | 1.46 | 2.56 |
| | Avg. efficiency | | 0.92 | 0.92 | 0.92 |
| | Length A | mm | 242 | 252 | 246 |
| | Installation length | mm | 438 | 438 | 476 |
| Weight | kg | 4.9 | 7.1 | 11.7 | |
| 2 Measurement transducer  | Code | 4DMC060 | 4DMC160 | | |
| | Order no. | 0 608 820 114 | 0 608 820 115 | You can configure your tightening spindle with a redundant measurement transducer from the same type. Connect both measurement transducers with the redundant adapter. For measurement transducer cables, see page 140. | |
| | Max. torque | Nm | 60 | 160 | |
| | Reduction | | 1 | 1 | |
| | Avg. efficiency | | 1 | 1 | |
| | Installation length | mm | 122 | 122 | |
| Weight | kg | 1.6 | 1.6 | | |
| 3a AVG adapter  | Code | 4AVG | | | |
| | Order no. | 0 608 801 008 | | The adapter connects the output drive and the planetary gearbox. | |
| | Reduction | | 1 | | |
| | Avg. efficiency | | 1 | | |
| | Installation length | mm | 26.5 | | |
| | Weight | kg | 0.4 | | |
| 3b AVR Redundant adapter  | Code | 4AVR | | | |
| | Order no. | 0 608 801 007 | | When configuring an offset output drive with integrated measurement transducer and redundant measurement transducer, the adapter connects both components. | |
| | Reduction | | 1 | | |
| | Avg. efficiency | | 1 | | |
| | Installation length | mm | 30.3 | | |
| | Weight | kg | 0.7 | | |

| 5 Planetary gearbox | Code | 4GE19 | 4GE59 |
|---|--|---------------|---------------|
|  | Order no. | 0 608 720 056 | 0 608 720 040 |
| | Reduction | 19.3 | 58.6 |
| | Avg. efficiency | 0.93 | 0.9 |
| | Installation length | mm 82.9 | 105.5 |
| | Weight | kg 0.7 | 1.1 |
| 6 Transverse gearbox | Code | 4ULG | |
|  | Order no. | 0 608 810 038 | |
| | Reduction | 1 | |
| | Avg. efficiency | 0.95 | |
| | Installation length | mm 41.3 | |
| | Weight | kg 1.3 | |
| | The transverse gearbox shortens the length of your tightening spindle by the installation length of the EC motor plus the installation length of the transverse gearbox. | | |
| 7 EC motor | Code | EC304 | |
|  | Order no. | 0 608 701 018 | |
| | Installation length | mm 247 | |
| | Weight | kg 2.7 | |

Side-by-side arrangement of tightening spindles (center-to-center distance)

| Number of tightening spindles | | 2 | 3 | 4 | 5 | 6 |
|---|---------|---|---|---|---|---|
| | |  |  |  |  |  |
| Min. circle diameter-Ø d _{min} | 4VMC150 | 44 | 51 | 63 | 75 | 88 |
| mm | 4VMC210 | 48 | 56 | 68 | 82 | 96 |
| | 4VMC360 | 57 | 66 | 81 | 97 | 114 |

Tightening spindles size 4

Angle head



- ▶ Working range 26–220 Nm
- ▶ Max. output drive speed 985 rpm

Depending on the size, the actual components may differ from those in the illustration.

FEATURES

- ▶ For restricted accessibility
- ▶ Precision tothing for high torque accuracy
- ▶ Incremental positioning (10° increments)
- ▶ Integrated fastening flanges
- ▶ With integrated measurement transducer on request

| Tightening spindle | | Angle head | | | Measurement transducer | Planetary gearbox | EC motor |
|---------------------|-----------------------------------|-------------------|-------|------------|------------------------|--------------------|--------------------|
| Working range Nm | Max. output drive speed rpm | Tool mount | Code | Order no. | Code/ Order no. | Code/ Order no. | Code/ Order no. |
| 26–54 | 985 | 1/2" square drive | 4W130 | 0608810045 | 4DMC060 | 4GE19 | EC304 |
| 44–86 | 620 | 3/4" square drive | 4W220 | 0608810046 | 0608820114 | 0608720056 | 0608701018 |
| 26–130 | 320 | 1/2" square drive | 4W130 | 0608810045 | 4DMC160 | 4GE59 | |
| 44–220 | 200 | 3/4" square drive | 4W220 | 0608810046 | 0608820115 | 0608720040 | |

Notes: To ensure troublefree operation, the angle head must always be operated with an output drive axial compensator, e.g. spindle bearing. See page 21.

For an output drive axial compensator, the following angle head/spindle bearing combinations are possible:





4W130 (0608810045) – spindle bearing size 4 (page 50)

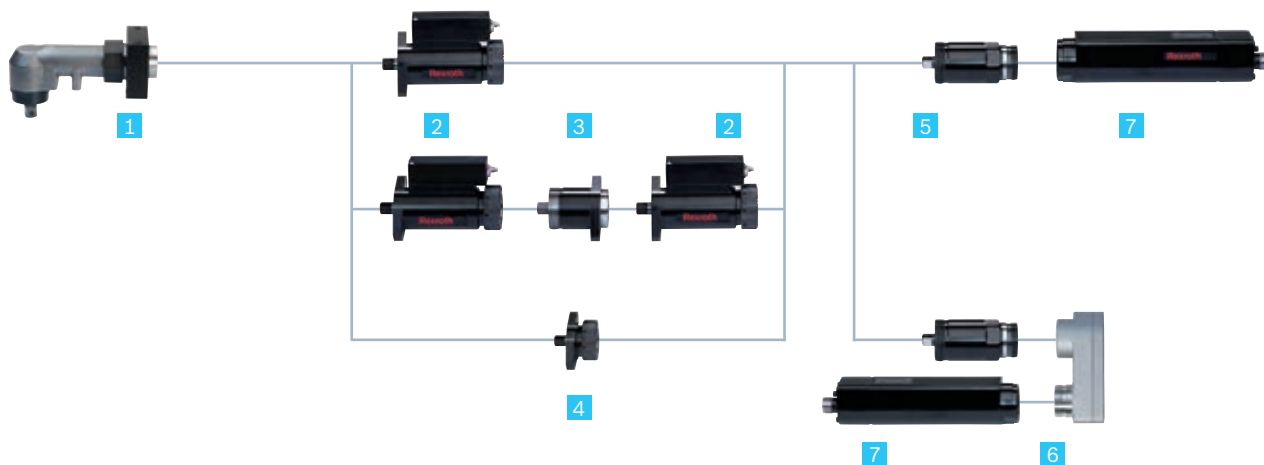

4W220 (0608810046) – on request





You can find component dimensions and 3D/CAD data on the Internet at www.boschrexroth.com/tightening

Angle head size 4 – components



| | | | | | |
|--|---------------------|----|----------------|----------------|---|
| 1 Angle head  | Code | | 4W130 | 4W220 | |
| | Order no. | | 0 608 810 045 | 0 608 810 046 | |
| | Max. torque | Nm | 130 | 220 | |
| | Reduction | | 1.05 | 1.67 | |
| | Avg. efficiency | | 0.95 | 0.95 | |
| | Installation length | mm | 141.5 | 141.5 | |
| | Weight | kg | 2.8 | 3.2 | |
| 2 Measurement transducer  | Code | | 4DMC060 | 4DMC160 | |
| | Order no. | | 0 608 820 114 | 0 608 820 115 | You can configure your tightening spindle with a redundant measurement transducer from the same type. Connect both measurement transducers with the redundant adapter. For measurement transducer cables, see page 140. |
| | Nominal torque | Nm | 60 | 160 | |
| | Reduction | | 1 | 1 | |
| | Avg. efficiency | | 1 | 1 | |
| | Installation length | mm | 122 | 122 | |
| | Weight | kg | 1.6 | 1.6 | |
| | | | | | |
| 3 Redundant adapter  | Code | | 4AR | | When configuring with a redundant measurement transducer, the adapter connects both measurement transducers. |
| | Order no. | | 0 608 810 022 | | |
| | Reduction | | 1 | | |
| | Avg. efficiency | | 1 | | |
| | Installation length | mm | 65 | | |
| | Weight | kg | 0.8 | | |
| 4 Adapter  | Code | | 4A | | When configuring without a measurement transducer, the adapter connects the output drive and the planetary gearbox. |
| | Order no. | | 0 608 810 026 | | |
| | Reduction | | 1 | | |
| | Avg. efficiency | | 1 | | |
| | Installation length | mm | 26.5 | | |
| | Weight | kg | 0.4 | | |

| | | | |
|--|---------------------|---------------|--|
| 5 Planetary gearbox  | Code | 4GE19 | 4GE59 |
| | Order no. | 0 608 720 056 | 0 608 720 040 |
| | Reduction | 19.3 | 58.6 |
| | Avg. efficiency | 0.93 | 0.9 |
| | Installation length | mm 82.9 | 105.5 |
| | Weight | kg 0.7 | 1.1 |
| 6 Transverse gearbox  | Code | 4ULG | |
| | Order no. | 0 608 810 038 | The transverse gearbox shortens the length of your tightening spindle by the installation length of the EC motor plus the installation length of the transverse gearbox. |
| | Reduction | 1 | |
| | Avg. efficiency | 0.95 | |
| | Installation length | mm 41.3 | |
| | Weight | kg 1.3 | |
| | | | |
| 7 EC motor  | Code | EC304 | |
| | Order no. | 0 608 701 018 | |
| | Installation length | mm 247 | |
| | Weight | kg 2.7 | |

| Side-by-side arrangement of tightening spindles (center-to-center distance) | | | | | | |
|--|-------|---|---|---|---|---|
| Number of tightening spindles | | 2 | 3 | 4 | 5 | 6 |
| | |  |  |  |  |  |
| Min. circle diameter-Ø d _{min} | 4W130 | 47 | 55 | 67 | 80 | 94 |
| mm | 4W220 | 62 | 72 | 88 | 106 | 124 |

Tightening spindles size 4

Feed output drive



- ▶ Working range 6 – 138 Nm
- ▶ Max. output drive speed 1,000 rpm

Depending on the size, the actual components may differ from those in the illustration.

FEATURES

- ▶ Integrated feed movement
- ▶ In connection with automatic bolt supply
- ▶ Standard tool mounts and compressed air connections
- ▶ Maintenance-free for 1 million full-load cycles





| Tightening spindle | | | Feed output drive | | | Measurement transducer | Planetary gearbox | EC motor |
|---------------------|--------------------------------|--------------|---|-------|---------------|------------------------|---------------------|---------------------|
| Working range Nm | Max. output drive speed rpm | Stroke mm | Tool mount | Code | Order no. | Code/ Order no. | Code/ Order no. | Code/ Order no. |
| 6*-49 | 1,000 | 200 | 1/2" square drive with centering pin | 4S1M8 | 0 608 800 650 | 4DMC060 0608820114 | 4GE19 0608720056 | EC304 0608701018 |
| 15*-138 | 340 | 200 | 1/2" square drive with centering pin | 4S1M8 | 0 608 800 650 | 4DMC160 0608820115 | 4GE59 0608720040 | |

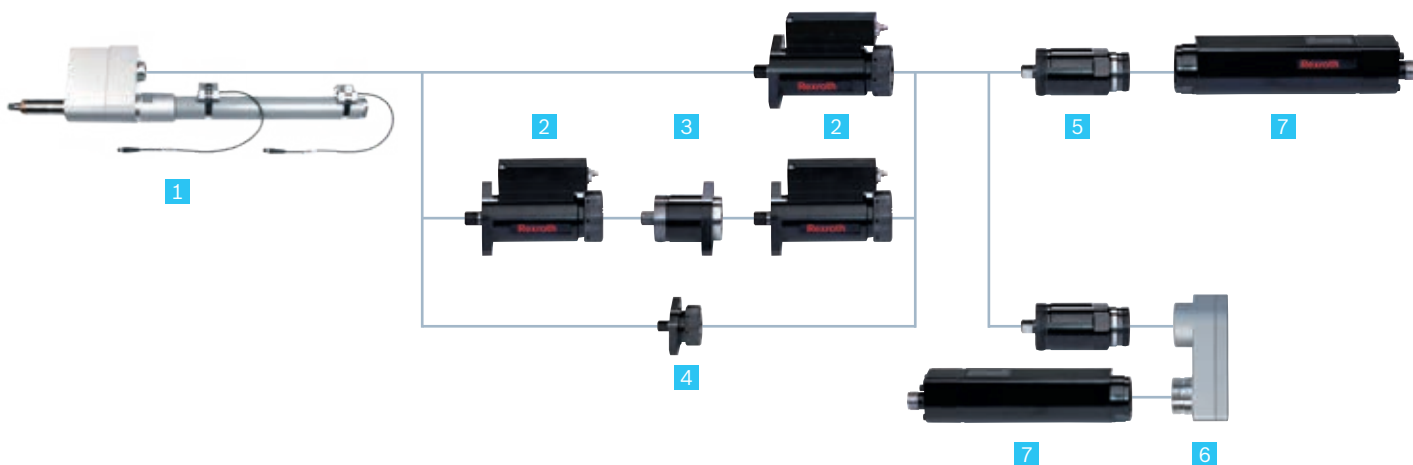

* Depending on the tolerance limits, position-based MCT required

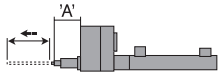



Note: You can find component dimensions and 3D/CAD data on the Internet at www.boschrexroth.com/tightening

Feed output drive size 4 – components



| | | | | | |
|--|---------------------|----------------|----------------|---|-----|
| 1 Feed output drive  | Code | 4S1M8 | | | |
| | Order no. | 0 608 800 650 | | | |
| | Max. torque | Nm | 150 | | |
| | Stroke | mm | 200 | | |
| | Max. air pressure | bar | 4 | | |
| | Reduction | | 1 | | |
| | Avg. efficiency | | 0.93 | | |
| | Length A | mm | 101 | | |
| | Installation length | mm | 219 | | |
| | Weight | kg | 6.6 | | |
| 2 Measurement transducer  | Code | 4DMC060 | 4DMC160 | | |
| | Order no. | 0 608 820 114 | 0 608 820 115 | You can configure your tightening spindle with a redundant measurement transducer from the same type. Connect both measurement transducers with the redundant adapter. For measurement transducer cables, see page 140. | |
| | Nominal torque | Nm | 60 | | 160 |
| | Reduction | | 1 | | 1 |
| | Avg. efficiency | | 1 | | 1 |
| | Installation length | mm | 122 | | 122 |
| Weight | kg | 1.6 | 1.6 | | |
| 3 Redundant adapter  | Code | 4AR | | | |
| | Order no. | 0 608 810 022 | | When configuring with a redundant measurement transducer, the adapter connects both measurement transducers. | |
| | Reduction | 1 | | | |
| | Avg. efficiency | 1 | | | |
| | Installation length | mm | 65 | | |
| Weight | kg | 0.8 | | | |
| 4 Adapter  | Code | 4A | | | |
| | Order no. | 0 608 810 026 | | When configuring without a measurement transducer, the adapter connects the output drive and the planetary gearbox. | |
| | Reduction | 1 | | | |
| | Avg. efficiency | 1 | | | |
| | Installation length | mm | 26.5 | | |
| Weight | kg | 0.4 | | | |

| | | | |
|--|---------------------|---------------|--|
| 5 Planetary gearbox  | Code | 4GE19 | 4GE59 |
| | Order no. | 0 608 720 056 | 0 608 720 040 |
| | Reduction | 19.3 | 58.6 |
| | Avg. efficiency | 0.93 | 0.9 |
| | Installation length | mm 82.9 | 105.5 |
| | Weight | kg 0.7 | 1.1 |
| 6 Transverse gearbox  | Code | 4ULG | |
| | Order no. | 0 608 810 038 | The transverse gearbox shortens the length of your tightening spindle by the installation length of the EC motor plus the installation length of the transverse gearbox. |
| | Reduction | 1 | |
| | Avg. efficiency | 0.95 | |
| | Installation length | mm 41.3 | |
| | Weight | kg 1.3 | |
| | | | |
| 7 EC motor  | Code | EC304 | |
| | Order no. | 0 608 701 018 | |
| | Installation length | mm 247 | |
| | Weight | kg 2.7 | |

| Side-by-side arrangement of tightening spindles (center-to-center distance) | | | | | | |
|--|-------|---|---|---|---|---|
| Number of tightening spindles | | 2 | 3 | 4 | 5 | 6 |
| | |  |  |  |  |  |
| Min. circle diameter- \varnothing d_{min} mm | 4S1M8 | 56 | 65 | 79 | 95 | 112 |

Tightening spindles size 5

Spindle bearing



- ▶ Working range 50–500 Nm
- ▶ Max. output drive speed 515 rpm

Depending on the size, the actual components may differ from those in the illustration.

FEATURES

- ▶ Various lengths with axial compensator
- ▶ Standard tool mounts
- ▶ Maximum efficiency
- ▶ Maintenance-free for 1 million full-load cycles





| Tightening spindle | | | Spindle bearing | | | Measurement transducer | Planetary gearbox | EC motor |
|--------------------|-------------------------|--|--------------------------------------|---------|---------------|--------------------------|------------------------|------------------------|
| Working range* | Max. output drive speed | Range of spring mm / max. spring force N | Tool mount | Code | Order no. | Code / Order no. | Code / Order no. | Code / Order no. |
| Nm | rpm | | | | | | | |
| 50-160 | 515 | 80/155 | 3/4" square drive with centering pin | GK3C281 | 0 608 800 079 | 5DMC530 0 608 820 116 | 5GE19 0 608 720 058 | EC305 0 608 701 019 |
| | | | | GK3C350 | 0 608 800 081 | | | |
| | | | | GL3C418 | 0 608 800 084 | | | |
| 50-500 | 145 | 80/155 | 3/4" square drive with centering pin | GK3C281 | 0 608 800 079 | | 5GE68 0 608 720 041 | |
| | | | | GK3C350 | 0 608 800 081 | | | |
| | | | | GL3C418 | 0 608 800 084 | | | |

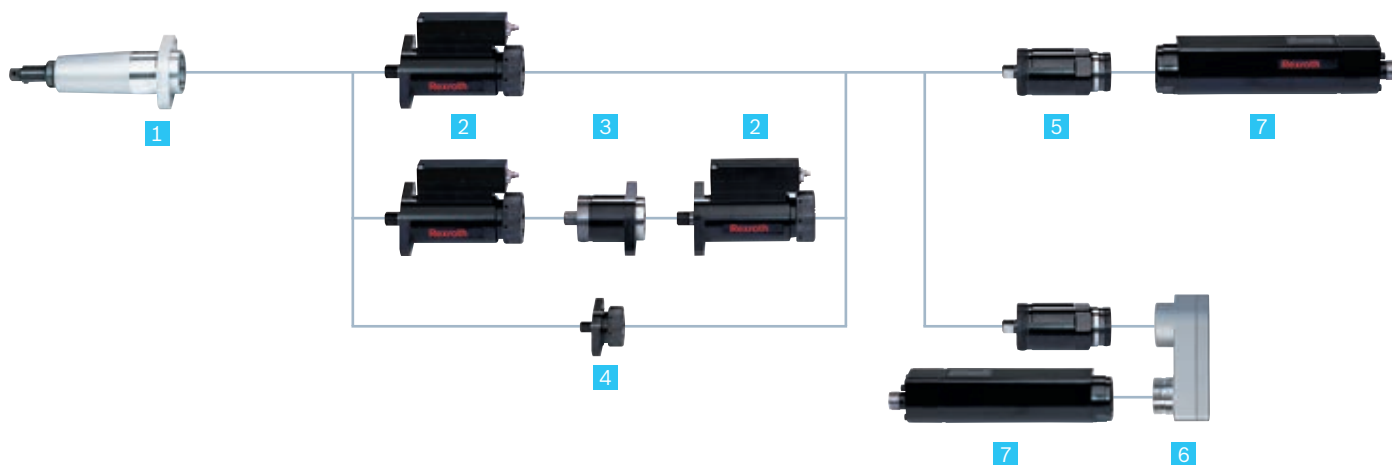

*The accuracy within the working range according to VDI/VDE 2647 is $\pm 2\%$ over 6 s.

Note: You can find component dimensions and 3D/CAD data on the Internet at www.boschrexroth.com/tightening





Spindle bearing size 5 – components



| | | | | | |
|--|---------------------|----------------|---|----------------|--------|
| 1 Spindle bearing  | Code | GK3C281 | GK3C350 | GL3C418 | |
| | Order no. | 0 608 800 079 | 0 608 800 081 | 0 608 800 084 | |
| | Max. torque | Nm | 500 | 500 | 500 |
| | Range of spring | mm | 80 | 80 | 80 |
| | Spring force | N | 40–155 | 40–155 | 40–155 |
| | Reduction | | 1 | 1 | 1 |
| | Avg. efficiency | | 1 | 1 | 1 |
| | Length A | mm | 284 | 353 | 421 |
| | Installation length | mm | 302 | 371 | 439 |
| | Weight | kg | 3 | 3.5 | 4.5 |
| 2 Measurement transducer  | Code | 5DMC530 | | | |
| | Order no. | 0 608 820 116 | | | |
| | Nominal torque | Nm | 530 | | |
| | Reduction | | 1 | | |
| | Avg. efficiency | | 1 | | |
| | Installation length | mm | 125.5 | | |
| | Weight | kg | 3.7 | | |
| 3 Redundant adapter  | Code | 5AR | | | |
| | Order no. | 0 608 810 023 | | | |
| | Reduction | | 1 | | |
| | Avg. efficiency | | 1 | | |
| | Installation length | mm | 108 | | |
| | Weight | kg | 2.4 | | |
| 4 Adapter  | Code | 5A | | | |
| | Order no. | 0 608 810 027 | | | |
| | Reduction | | 1 | | |
| | Avg. efficiency | | 1 | | |
| | Installation length | mm | 48.5 | | |
| | Weight | kg | 2.2 | | |
| | | | When configuring with a redundant measurement transducer, the adapter connects both measurement transducers. | | |
| | | | When configuring without a measurement transducer, the adapter connects the output drive and the planetary gearbox. | | |

| 5 Planetary gearbox | Code | 5GE19 | 5GE68 |
|---|---------------------|--|---------------|
|  | Order no. | 0 608 720 058 | 0 608 720 041 |
| | Reduction | 19.3 | 67.9 |
| | Avg. efficiency | 0.93 | 0.9 |
| | Installation length | mm 154 | 188 |
| | Weight | kg 2.9 | 3.7 |
| 6 Transverse gearbox | Code | 5ULG | |
|  | Order no. | 0 608 810 039 | |
| | Reduction | 1 | |
| | Avg. efficiency | 0.95 | |
| | Installation length | mm 63.8 | |
| | Weight | kg 3.2 | |
| | | The transverse gearbox shortens the length of your tightening spindle by the installation length of the EC motor plus the installation length of the transverse gearbox. | |
| 7 EC motor | Code | EC305 | |
|  | Order no. | 0 608 701 019 | |
| | Installation length | mm 304 | |
| | Weight | kg 6.4 | |

Side-by-side arrangement of tightening spindles (center-to-center distance)

| Number of tightening spindles | 2 | 3 | 4 | 5 | 6 |
|--|---|---|---|---|---|
| |  |  |  |  |  |
| Min. circle diameter- \varnothing d _{min} mm | G... 86 | 100 | 131 | 162 | 172 |

Tightening spindles size 5

Offset output drive



- ▶ Working range 50–1,000 Nm
- ▶ Max. output drive speed 515 rpm

Depending on the size, the actual components may differ from those in the illustration.

FEATURES

- ▶ For tight hole templates
- ▶ Standard tool mounts
- ▶ Maintenance-free for 1 million full-load cycles





| Tightening spindle | | | Offset output drive | | | Measurement transducer | Planetary gearbox | EC motor |
|---------------------|--------------------------------|-----------------------|--------------------------------------|----------|---------------|--------------------------|------------------------|------------------------|
| Working range Nm | Max. output drive speed rpm | Range of spring mm | Tool mount | Code | Order no. | Code/ Order no. | Code/ Order no. | Code/ Order no. |
| 50*-148 | 515 | 80 | 3/4" square drive with centering pin | VNK3C281 | 0 608 800 543 | 5DMC530 0 608 820 116 | 5GE19 0 608 720 058 | EC305 0 608 701 019 |
| | | | | VNK3C350 | 0 608 800 545 | | | |
| | | | | VNL3C418 | 0 608 800 548 | | | |
| 115*-365 | 200 | 80 | 1" square drive with centering pin | VUK3D316 | 0 608 PE0 017 | | | |
| | | | | VUK3D384 | 0 608 PE0 180 | | | |
| 50*-463 | 145 | 80 | 3/4" square drive with centering pin | VNK3C281 | 0 608 800 543 | | 5GE68 0 608 720 041 | |
| | | | | VNK3C350 | 0 608 800 545 | | | |
| | | | | VNL3C418 | 0 608 800 548 | | | |
| 115*-1,000 | 55 | 80 | 1" square drive with centering pin | VUK3D316 | 0 608 PE0 017 | | | |
| | | | | VUK3D384 | 0 608 PE0 180 | | | |

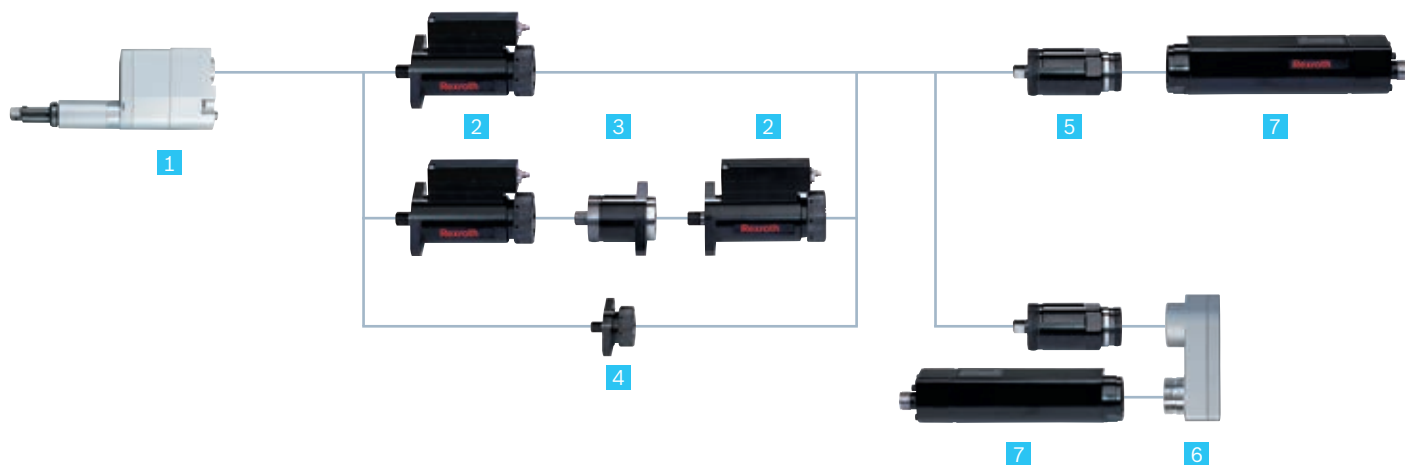

* Depending on the tolerance limits, position-based MCT required





Note: You can find component dimensions and 3D/CAD data on the Internet at www.boschrexroth.com/tightening

Offset output drive size 5 – components



| | | | | | | | |
|--|---------------------|-----------------|-----------------|-----------------|---|-----------------|---------|
| 1 Offset output drive  | Code | VNK3C281 | VNK3C350 | VNL3C418 | VUK3D316 | VUK3D384 | |
| | Order no. | 0 608 800 543 | 0 608 800 545 | 0 608 800 548 | 0 608 PE0 017 | 0 608 PE0 180 | |
| | Max. torque | Nm | 500 | 500 | 500 | 1,000 | 1,000 |
| | Range of spring | mm | 80 | 80 | 80 | 80 | 80 |
| | Spring force | N | 40–155 | 40–155 | 40–155 | 150–293 | 150–293 |
| | Reduction | | 1 | 1 | 1 | 2.51 | 2.51 |
| | Avg. efficiency | | 0.92 | 0.92 | 0.92 | 0.9 | 0.9 |
| | Length A | mm | 284 | 353 | 421 | 320 | 388 |
| | Installation length | mm | 482 | 551 | 619 | 572 | 640 |
| Weight | kg | 11.7 | 11.7 | 12.9 | 30 | 32 | |
| 2 Measurement transducer  | Code | 5DMC530 | | | | | |
| | Order no. | 0 608 820 116 | | | You can configure your tightening spindle with a redundant measurement transducer from the same type. Connect both measurement transducers with the redundant adapter. For measurement transducer cables, see page 140. | | |
| | Nominal torque | Nm | 530 | | | | |
| | Reduction | | 1 | | | | |
| | Avg. efficiency | | 1 | | | | |
| | Installation length | mm | 125.5 | | | | |
| Weight | kg | 3.7 | | | | | |
| 3 Redundant adapter  | Code | 5AR | | | | | |
| | Order no. | 0 608 810 023 | | | When configuring with a redundant measurement transducer, the adapter connects both measurement transducers. | | |
| | Reduction | | 1 | | | | |
| | Avg. efficiency | | 1 | | | | |
| | Installation length | mm | 108 | | | | |
| Weight | kg | 2.4 | | | | | |
| 4 Adapter  | Code | 5A | | | | | |
| | Order no. | 0 608 810 027 | | | When configuring without a measurement transducer, the adapter connects the output drive and the planetary gearbox. | | |
| | Reduction | | 1 | | | | |
| | Avg. efficiency | | 1 | | | | |
| | Installation length | mm | 48.5 | | | | |
| Weight | kg | 2.2 | | | | | |

| | | | |
|---|---------------------|---------------|--|
| 5 Planetary gearbox  | Code | 5GE19 | 5GE68 |
| | Order no. | 0 608 720 058 | 0 608 720 041 |
| | Reduction | 19.3 | 67.9 |
| | Avg. efficiency | 0.93 | 0.9 |
| | Installation length | mm 154 | 188 |
| | Weight | kg 2.9 | 3.7 |
| 6 Umlenkgetriebe  | Code | 5ULG | |
| | Order no. | 0 608 810 039 | The transverse gearbox shortens the length of your tightening spindle by the installation length of the EC motor plus the installation length of the transverse gearbox. |
| | Reduction | 1 | |
| | Avg. efficiency | 0.95 | |
| | Installation length | mm 63.8 | |
| | Weight | kg 3.2 | |
| 7 EC-Motor  | Code | EC305 | |
| | Order no. | 0 608 701 019 | |
| | Installation length | mm 304 | |
| | Weight | kg 6.4 | |

| Side-by-side arrangement of tightening spindles (center-to-center distance) | | | | | | |
|--|-------|---|---|---|---|---|
| Number of tightening spindles | | 2 | 3 | 4 | 5 | 6 |
| | |  |  |  |  |  |
| Min. circle diameter- \varnothing d _{min} mm | VN... | 61 | 71 | 87 | 104 | 122 |
| | VU... | 94 | 108 | 133 | 159 | 187 |

Accessories for tightening spindles



ANGLE HEADS WITH OR WITHOUT STROKE
for size 4 and 5 tightening spindles – on request



**ANGLE HEADS WITH INTEGRATED MEASUREMENT
TRANSDUCER - ON REQUEST**



ANGLE HEADS WITH HOLD AND DRIVE
on request



BLOCK OUTPUT DRIVES
on request



SOCKET TRAYS

on request



PROGRAMM SELECTOR SWITCH

on request



FEED GRIPPERS

on request



TELESCOPIC SUSPENSION

on request

Customized solutions and projects



HANDLING DEVICES

with torque support for tightening spindles and ErgoSpin hand-held nutrunners



TELESCOPIC BALANCER

for fatigue-free work with hand-held tightening spindles thanks to low displacement resistance



WORKER GUIDES AND AUTOMATED SOLUTIONS
for all aspects of the tightening position

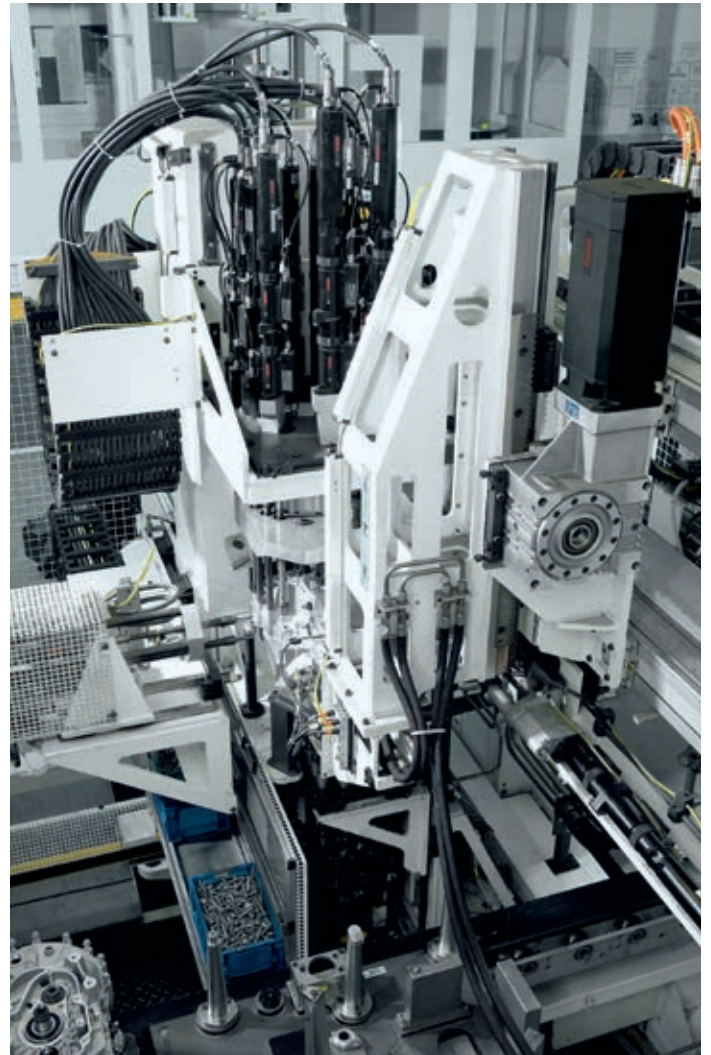

FULLY AUTOMATIC TIGHTENING STATIONS
also with nutrunner supply – that can be completely
integrated into production lines

Customized solutions and projects

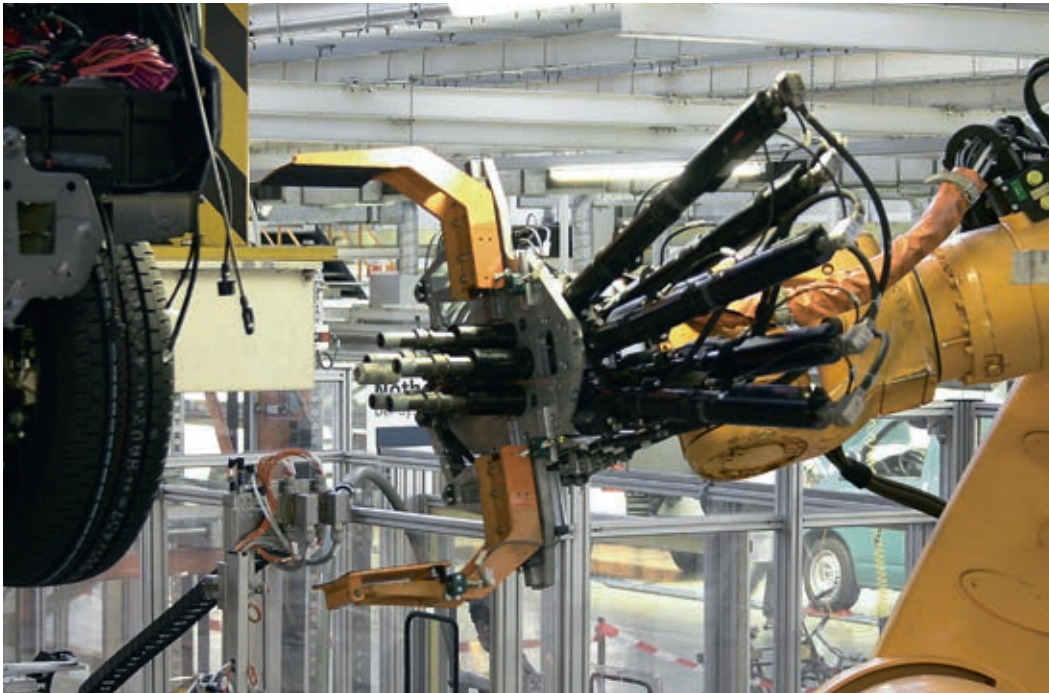

**ROBOT CONTROLLED
WHEEL MULTI**
for the automotive industry

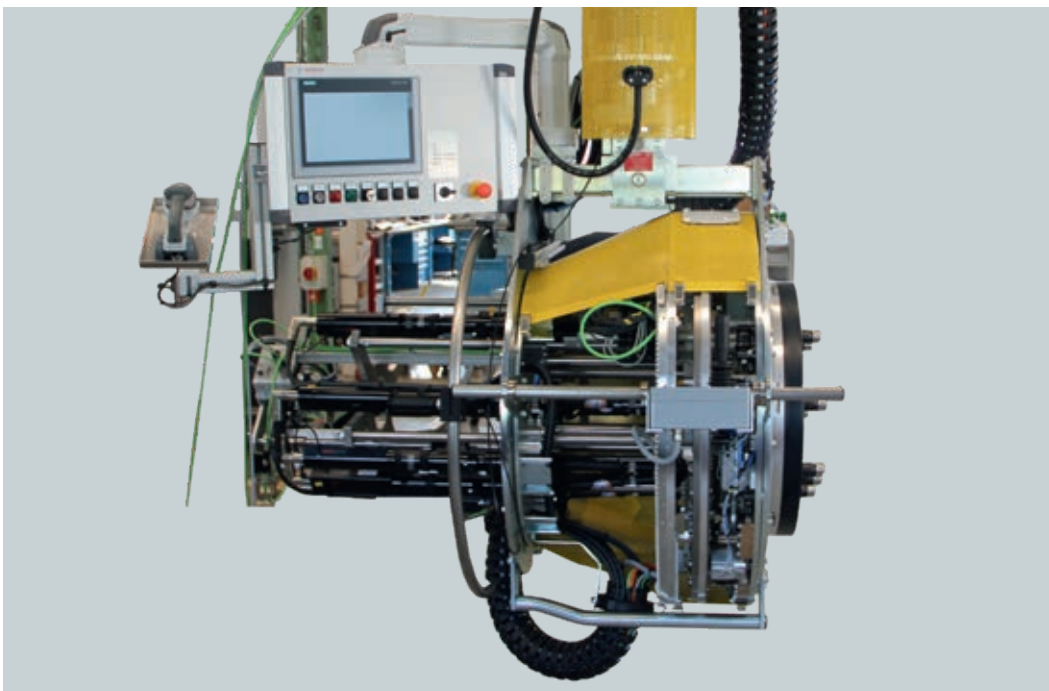

**8-SPINDLE REAR AXLE
MULTI**
with adjustable pitch
circle diameter and
integrated nut changer



AXLE NUT TIGHTENING



PLANETARY GEAR TIGHTENING

ErgoSpin – ergonomic, powerful, handy

The ErgoSpin is designed according to the latest findings in ergonomics and fits the user's hand like a glove. The ergonomics of the handle, its light weight, and the optimum arrangement of operating and display elements increase worker productivity. New: From now on, the angle compensation function can be activated by a license stick for all ErgoSpin hand-held nutrunners with an integrated measurement transducer.



- ▶ Fast commissioning
- ▶ Flexible stock-keeping: only 1 cable type for all variants
- ▶ Maximum precision thanks to digital data transfer
- ▶ Ergonomic handling due to a rubber-coated angle head with a safety flange
- ▶ Process reliability thanks to clearly arranged display elements
- ▶ CC-ErgoSpin variant for function-critical tightening jobs



VARIANT ESM

Pistolgrip nutrunner with integrated powerful LED for tightening position illumination



VARIANT GripLine

Right-angle nutrunner with plastic-covered angle head for protection against scratches and accidental contacts as well as a second grip



VARIANT SlimLine

Right-angle nutrunner with slim angle head for high accessibility



VARIANT VarioLine

Zero-play spur gearing for free connection of crowfoot wrenches and special output drives

Hand-held nutrunner

ESM ErgoSpin pistolgrip nutrunner for safety-critical tightening jobs



- ▶ With square tool mount, quick-change chuck, 1/4" or 3/8" square tool mount
- ▶ Working range 2.4 – 35 Nm
- ▶ Max. output drive speed 1,700 rpm
- ▶ With integrated measurement transducer
- ▶ Suitable for safety-critical tightening jobs in accordance with VDI/VDE 2862

FEATURES

- ▶ Pistolgrip nutrunner, also suitable for hard-to-reach tightening positions
- ▶ With integrated powerful LED
- ▶ Standard tool mounts
- ▶ Tested for one million cycles under full load without maintenance



ESM WITH SQUARE TOOL MOUNT

- ▶ Working range 2.4 – 35 Nm
- ▶ Max. output drive speed 1,700 rpm

| Working range Nm | Max. output drive speed rpm | Tool mount | Weight kg | Installation length mm | Code | Order-no. |
|---------------------|--------------------------------|-------------------|--------------|---------------------------|------------|------------|
| 2.4–12 | 1,090 | 1/4" square drive | 1 | 190 | ESM012SD-G | 0608841254 |
| 5–25 | 1,700 | 3/8" square drive | 1.4 | 223 | ESM025SD-G | 0608841256 |
| 7–35 | 1,025 | 3/8" square drive | 1.4 | 223 | ESM035SD-G | 0608841258 |



ESM WITH QUICK-CHANGE CHUCK TOOL MOUNT

- ▶ Working range 2.4 – 12 Nm
- ▶ Max. output drive speed 1,090 rpm

| Working range Nm | Max. output drive speed rpm | Tool mount | Weight kg | Installation length mm | Code | Order-no. |
|---------------------|--------------------------------|-------------------------|--------------|---------------------------|------------|------------|
| 2.4–12 | 1,090 | 1/4" quick-change chuck | 1 | 201 | ESM012QD-G | 0608841255 |



ESM WITH 3/8" SQUARE TOOL MOUNT

- ▶ Working range 5 – 25 Nm
- ▶ Max. output drive speed 1,700 rpm

| Working range Nm | Max. output drive speed rpm | Tool mount | Weight kg | Installation length mm | Code | Order-no. |
|---------------------|--------------------------------|---|--------------|---------------------------|------------|------------|
| 5–25 | 1,700 | 3/8" square drive and zero play spur gearing for free connection of special output drives | 1.4 | 223 | ESM025HT-G | 0608841257 |

Note: For special output drives and planetary gearboxes suitable for the ErgoSpin, see "Accessories for ErgoSpin / CC-ErgoSpin hand-held nutrunners" on page 94.

Hand-held nutrunner ErgoSpin GripLine for safety-critical tightening jobs



- ▶ Working range 1 – 75 Nm
- ▶ Max. output drive speed 1,000 rpm
- ▶ With integrated measurement transducer
- ▶ Suitable for safety-critical tightening jobs in accordance with VDI/VDE 2862

FEATURES

- ▶ Standard tool mounts
- ▶ Integrated LEDs visible all around
- ▶ Tested for one million cycles under full load without maintenance

| Working range | Max. output drive speed | Tool mount | Weight | Installation length | Code | Order no. |
|---------------|-------------------------|-------------------|--------|---------------------|-----------|------------|
| Nm | rpm | | kg | mm | | |
| 1–5 | 1,000 | 1/4" square drive | 1.3 | 385 | ESA005G-G | 0608841224 |
| 2.6–13 | 1,000 | 1/4" square drive | 1.3 | 385 | ESA013G-G | 0608841225 |
| 6–30 | 800 | 3/8" square drive | 1.6 | 423.5 | ESA030G-G | 0608841226 |
| 8–40 | 1,000 | 3/8" square drive | 1.8 | 437 | ESA040G-G | 0608841227 |
| 11–56 | 710 | 3/8" square drive | 1.9 | 453 | ESA056G-G | 0608841228 |
| 13–65 | 610 | 1/2" square drive | 1.9 | 453 | ESA065G-G | 0608841229 |
| 15–75 | 530 | 1/2" square drive | 2.1 | 454 | ESA075G-G | 0608841230 |

Hand-held nutrunner ErgoSpin SlimLine for safety-critical tightening jobs



- ▶ Working range 1 – 220 Nm
- ▶ Max. output drive speed 1,000 rpm
- ▶ With integrated measurement transducer
- ▶ Suitable for safety-critical tightening jobs in accordance with VDI/VDE 2862

FEATURES

- ▶ Angle head has a non-interchangeable code and can be turned and locked in 15-degree steps
- ▶ Integrated LEDs visible all around
- ▶ Tested for one million cycles under full load without maintenance

| Working range | Max. output drive speed | Tool mount | Weight | Installation length | Code | Order no. |
|---------------|-------------------------|-------------------|--------|---------------------|-----------|------------|
| Nm | rpm | | kg | mm | | |
| 1–5 | 1,000 | 1/4" square drive | 1.3 | 382 | ESA005S-G | 0608841204 |
| 2.6–13 | 1,000 | 1/4" square drive | 1.3 | 382 | ESA013S-G | 0608841205 |
| 6–30 | 800 | 3/8" square drive | 1.6 | 416 | ESA030S-G | 0608841206 |
| 8–40 | 1,000 | 3/8" square drive | 1.7 | 434 | ESA040S-G | 0608841207 |
| 11–56 | 710 | 3/8" square drive | 1.9 | 446 | ESA056S-G | 0608841208 |
| 13–65 | 610 | 1/2" square drive | 1.9 | 448 | ESA065S-G | 0608841209 |
| 15–75 | 530 | 1/2" square drive | 2 | 450 | ESA075S-G | 0608841210 |
| 20–100 | 630 | 1/2" square drive | 3.1 | 492 | ESA100S-G | 0608841211 |
| 30–150 | 380 | 1/2" square drive | 3.8 | 531 | ESA150S-G | 0608841212 |
| 44–220 | 260 | 3/4" square drive | 4 | 541 | ESA220S-G | 0608841213 |

Hand-held nutrunner ErgoSpin VarioLine for safety-critical tightening jobs



- ▶ Working range 1 – 146 Nm
- ▶ Max. output drive speed 1,700 rpm
- ▶ With integrated measurement transducer
- ▶ Suitable for safety-critical tightening jobs in accordance with VDI/VDE 2862

FEATURES

- ▶ Extended application options in combination with handling devices and special output drives (e.g. crowfoot wrenches)
- ▶ Can be used as a tightening spindle with output drive adapters
- ▶ Fully suitable for robot use
- ▶ Tested for one million cycles under full load without maintenance

| Working range Nm | Max. output speed drive rpm | Tool mount | Weight kg | Installation length mm | Code | Order no. |
|---------------------|-----------------------------------|---|--------------|------------------------------|----------|------------|
| 1–5 | 1,090 | Standard machine with an output with zero-play spur gearing for the attachment of special output drives | 1.1 | 333 | ESV005-G | 0608841243 |
| 2.4–12 | 1,090 | | 1.1 | 333 | ESV012-G | 0608841244 |
| 5–25 | 1,700 | | 1.4 | 365 | ESV025-G | 0608841245 |
| 10–50 | 830 | | 1.5 | 375 | ESV050-G | 0608841246 |
| 14–73 | 900 | | 2.4 | 406 | ESV073-G | 0608841247 |
| 29–146 | 420 | | 2.8 | 430 | ESV146-G | 0608841248 |

Hand-held nutrunner ESM CC-ErgoSpin pistolgrip nutrunner for function-critical tightening jobs



- ▶ Working range 2.4 – 25 Nm
- ▶ Max. output drive speed 1,700 rpm
- ▶ Current-controlled nutrunner
- ▶ Suitable for function-critical tightening jobs in accordance with VDI/VDE 2862

FEATURES

- ▶ With integrated powerful LED
- ▶ Standard tool mounts
- ▶ Tested for one million cycles under full load without maintenance

| Working range | Max. output speed drive | Tool mount | Weight | Installation length | Code | Order no. |
|---------------|-------------------------|---|--------|---------------------|-------------|------------|
| Nm | 1/min | | kg | mm | | |
| 2.4 – 12 | 1,090 | 1/4" quick-change chuck | 1 | 201 | CC-ESM012QD | 0608841089 |
| 5 – 25 | 1,700 | 3/8" square drive and zero-play spur gearing for free connection of special output drives | 1.4 | 223 | CC-ESM025HT | 0608841094 |

Note: For special output drives and planetary gearboxes suitable for the ErgoSpin, see "Accessories for ErgoSpin / CC-ErgoSpin hand-held nutrunners" on page 94.

Hand-held nutrunner CC-ErgoSpin SlimLine for function-critical tightening jobs



- ▶ Working range 6–100 Nm
- ▶ Max. output drive speed 1,000 rpm
- ▶ Current-controlled nutrunner
- ▶ Suitable for function-critical tightening jobs in accordance with VDI/VDE 2862

FEATURES

- ▶ Angle head has a non-interchangeable code and can be turned and locked in 15-degree steps
- ▶ Integrated LEDs visible all around
- ▶ Tested for one million cycles under full load without maintenance

| Working range | Max. output drive speed | Tool mount | Weight | Installation length | Code | Order no. |
|---------------|-------------------------|-------------------|--------|---------------------|------------|------------|
| Nm | 1/min | | kg | mm | | |
| 6–30 | 800 | 3/8" square drive | 1.6 | 416 | CC-ESA030S | 0608841087 |
| 8–40 | 1,000 | 3/8" square drive | 1.7 | 434 | CC-ESA040S | 0608841088 |
| 20–100 | 630 | 1/2" square drive | 3.1 | 492 | CC-ESA100S | 0608841092 |

Hand-held nutrunner CC-ErgoSpin VarioLine for function-critical tightening jobs



- ▶ Working range 2.4 – 146 Nm
- ▶ Max. output drive speed 1,090 rpm
- ▶ Current-controlled nutrunner
- ▶ Suitable for function-critical tightening jobs in accordance with VDI/VDE 2862

FEATURES

- ▶ Extended application options in combination with handling devices and special output drives
- ▶ Can be used as a tightening spindle with output drive adapters
- ▶ Fully suitable for robot use
- ▶ Integrated LEDs visible all around
- ▶ Tested for one million cycles under full load without maintenance

| Working range | Max. output drive speed | Tool mount | Weight | Installation length | Code | Order no. |
|---------------|-------------------------|---|--------|---------------------|-----------|------------|
| Nm | 1/min | | kg | mm | | |
| 2.4 – 12 | 1,090 | Standard machine with an output with zero-play spur gearing for the attachment of special output drives | 1.1 | 333 | CC-ESV012 | 0608841090 |
| 10 – 50 | 830 | | 1.5 | 376 | CC-ESV050 | 0608841093 |
| 29 – 146 | 420 | | 2.8 | 430 | CC-ESV146 | 0608841091 |

Output drives for ErgoSpin/CC-ErgoSpin VarioLine

In combination with handling devices and output adapters the hand-held nutrunner VarioLine becomes a tightening spindle. This offers extended application options and makes it fully suitable for robot use.

ANGLE HEADS

You can mount different angle heads on the ErgoSpin VarioLine. This makes your ErgoSpin hand-held nutrunner suitable for a variety of applications.

With an angle head for special output drives, you can e.g. mount a crowfoot wrench to the VarioLine.

VarioLine COMBINATION OPTIONS WITH ANGLE HEADS



| ErgoSpin VarioLine Code | Code | Tool mount | Weight kg | Max. torque** Nm | Reduction | Avg. efficiency | Order no. |
|-------------------------|---------|-------------------|-----------|------------------|-----------|-----------------|------------|
| ESV005/ CC-ESV005 | WH013S | 1/4" square drive | 0.2 | 13 | 1.1 | 0.95 | 3608876051 |
| | WH013G* | 1/4" square drive | 0.2 | 13 | 1.1 | 0.95 | 3608876052 |
| ESV012/ CC-ESV012 | WH013S | 1/4" square drive | 0.2 | 13 | 1.1 | 0.95 | 3608876051 |
| | WH013G* | 1/4" square drive | 0.2 | 13 | 1.1 | 0.95 | 3608876052 |
| ESV025 | WH040S | 3/8" square drive | 0.4 | 40 | 1.73 | 0.95 | 3608876055 |
| | WH040G* | 3/8" square drive | 0.4 | 40 | 1.73 | 0.95 | 3608876056 |
| ESV050/ CC-ESV050 | WH056S | 3/8" square drive | 0.5 | 56 | 1.16 | 0.95 | 3608876057 |
| | WH056G* | 3/8" square drive | 0.6 | 56 | 1.16 | 0.95 | 3608876058 |
| | WH065S | 1/2" square drive | 0.5 | 65 | 1.35 | 0.95 | 3608876059 |
| | WH065G* | 1/2" square drive | 0.7 | 65 | 1.35 | 0.95 | 3608876060 |
| | WH075S | 1/2" square drive | 0.5 | 75 | 1.56 | 0.95 | 3608876061 |
| | WH075G* | 1/2" square drive | 0.7 | 75 | 1.56 | 0.95 | 3608876062 |
| ESV073 | WH100S | 1/2" square drive | 0.7 | 100 | 1.42 | 0.95 | 3608876063 |
| ESV0146/ CC-ESV146 | WH150S | 1/2" square drive | 1.0 | 150 | 1.1 | 0.95 | 3608876064 |
| | WH220S | 3/4" square drive | 1.3 | 220 | 1.59 | 0.95 | 3608876065 |



| ErgoSpin VarioLine Code | Code | Tool mount | Weight kg | Max. torque** Nm | Reduction | Avg. efficiency | Order no. |
|-------------------------|--------|-------------------|-----------|------------------|-----------|-----------------|------------|
| ESV025 | WHS040 | 3/8" square drive | 0.5 | 40 | 1.73 | 0.95 | 3608876081 |
| ESV050/ CC-ESV050 | WHS075 | 1/2" square drive | 0.7 | 75 | 1.56 | 0.95 | 3608876082 |
| ESV073 | WHS100 | 1/2" square drive | 0.9 | 100 | 1.42 | 0.95 | 3608876083 |

* Plastic-covered titanium angle head as a second grip

** Value refers to angle head

STRAIGHT OUTPUT DRIVES

Straight output drives combined with the ErgoSpin VarioLine produce a straight nutrunner. The combination of VarioLine and straight output drives supplies an ergonomic

solution for tightening cases of up to 12 Nm: whether vertically suspended, as a hand-held straight nutrunner, a hand-held application, or in connection with handling devices.

VarioLine COMBINATION OPTIONS WITH STRAIGHT OUTPUT DRIVES*



| ErgoSpin VarioLine Code | Working range Nm | Tool mount | Reduction | Avg. efficiency | Installation length mm | Weight kg | Code | Order no. |
|--------------------------|------------------|-------------------------|-----------|-----------------|------------------------|-----------|----------|------------|
| ESV005 | 1–5 | 1/4" square drive | 1 | 1 | 31.5 | 0.1 | ESISA012 | 0608810047 |
| | 1–5 | 1/4" quick-change chuck | 1 | 1 | 31.5 | 0.1 | ESIQA012 | 0608810048 |
| ESV012/ CC- ESV012 | 2.4–12 | 1/4" square drive | 1 | 1 | 31.5 | 0.1 | ESISA012 | 0608810047 |
| | 2.4–12 | 1/4" quick-change chuck | 1 | 1 | 31.5 | 0.1 | ESIQA012 | 0608810048 |

OUTPUT DRIVE ADAPTERS

With the output drive adapters, you can combine the ErgoSpin VarioLine with output drives in sizes 2, 3, and 4 for tightening spindles and e.g. use it as a tightening spindle.

VarioLine COMBINATION OPTIONS WITH OUTPUT DRIVE ADAPTERS*



| ErgoSpin VarioLine Code | Working range Nm | Tool mount | Reduction | Avg. efficiency | Installation length mm | Weight kg | Code | Order no. |
|-------------------------|------------------|------------|-----------|-----------------|------------------------|-----------|---------|------------|
| ESV005 | 1–5 | Size 2 | 1 | 1 | 41.4 | 0.1 | ESOA012 | 0608810049 |
| ESV012/ CC-ESV012 | 2.4–12 | Size 2 | 1 | 1 | 41.4 | 0.1 | ESOA012 | 0608810049 |
| ESV025 | 5–25 | Size 3 | 1 | 1 | 40.3 | 0.1 | ESOA025 | 0608810050 |
| ESV050/ CC-ESV050 | 10–50 | Size 3 | 1 | 1 | 41.2 | 0.2 | ESOA050 | 0608810051 |
| ESV073 | 14–73 | Size 4 | 1 | 1 | 44.5 | 0.3 | ESOA073 | 0608810052 |
| ESV146/ CC-ESV146 | 29–146 | Size 4 | 1 | 1 | 44 | 0.3 | ESOA146 | 0608810053 |

* Special output drives on request

Accessories for ErgoSpin / CC-ErgoSpin hand-held nutrunners



HOLDER FOR RIGHT-ANGLE NUTRUNNER AND STRAIGHT NUTRUNNER

| Code | Order no. |
|------|------------|
| ESAT | 3608876626 |

PRESENCE DETECTION SENSORS

| |
|------------|
| On request |
|------------|



HOLDER FOR ESM PISTOLGRIP NUTRUNNER

| Code | Order no. |
|------|------------|
| ESMT | 3608877433 |

PRESENCE DETECTION SENSORS

| |
|------------|
| On request |
|------------|



TURNING SUSPENSION

| Code | Ø mm | ErgoSpin | Order no. | Weight g |
|-------|------|------------|------------|----------|
| ESMH1 | 50 | ESA005-075 | 3608875426 | 100 |
| | | ESV005-050 | | |
| ESMH2 | 63 | ESA100-220 | 3608875921 | 145 |
| | | ESV073-146 | | |

TURNING SUSPENSION WITH EXTENSION

| |
|------------|
| On request |
|------------|



SUSPENSION FOR ERGOSPIN PISTOLGRIP NUTRUNNER

| Code | Order no. |
|------|------------|
| ESMB | 3608876767 |



EXTENSION

| Code | Installation length mm | ErgoSpin | Order no. |
|---------|------------------------|-----------------|------------|
| ESET040 | 200 | ESA040 / ESV025 | On request |
| ESET056 | 250 | ESA056 / ESV050 | |
| ESET065 | 250 | ESA065 / ESV050 | |
| ESET075 | 250 | ESA075 / ESV050 | |
| ESET100 | 250 | ESA100 / ESV073 | |



EXTRA GRIP

| Code | ErgoSpin | Order no. |
|--------|------------------------------|---------------|
| ESMH12 | ESM012SD, ESM012QD | 3 608 877 111 |
| ESMH25 | ESM025SD, ESM025HT, ESM035SD | 3 608 877 112 |



VERTICAL SUSPENSION

| Code | ErgoSpin | Order no. | Weight g |
|------|-----------|---------------|----------|
| ESMV | ESA / ESV | 3 608 875 435 | 180 |

START LEVER EXTENSION FOR STRAIGHT NUTRUNNERS INCL. VERTICAL SUSPENSION

| Code | ErgoSpin | Order no. | Weight g |
|------|--------------------------|---------------|----------|
| ESTE | ESA005-075 ESV005-050 | 3 608 876 175 | 235 |

Accessories for ErgoSpin / CC-ErgoSpin hand-held nutrunners



STROKE EXTENSION

| Code | Order no. |
|------|------------|
| ESSE | 3608876746 |



ADAPTER WITH HOLES FOR HANDLING DEVICES

| Code | ErgoSpin | Order no. |
|--------|------------------------|------------|
| ESCU1B | ESA005-075, ESV005-050 | 3608876459 |
| ESCU2B | ESA100-220, ESV073-146 | 3608876409 |



ADAPTER WITHOUT HOLES FOR HANDLING DEVICES

| Code | ErgoSpin | Order no. |
|--------|------------------------|------------|
| ESCU1F | ESA005-075, ESV005-050 | 3608876751 |
| ESCU2F | ESA100-220, ESV073-146 | 3608876749 |



TORQUE SUPPORT WITH OR WITHOUT TOOL BALANCER

On request

You can choose from a large number of variants. The torque supports differ in drive direction (vertical/horizontal), extension length and torque range.



SOCKET TRAY

On request

You can choose from a large number of variants. The socket trays are available with four or eight slots and can be expanded to up to 32 slots with additional modules. The following connection variants are available: fieldbus connections (PROFIBUS, PROFINET, Ethernet/Open Modbus UDP/TCP), 24V I/O, Open Protocol and WiFi.



ERGOSPIN WITH INTEGRATED SCANNER

On request



PLANETARY GEARBOXES FOR HIGH TORQUES UP TO 1,000 NM

On request



CROWFOOT WRENCH FOR ERGOSPIN NUTRUNNERS

On request

Accessories for ErgoSpin / CC-ErgoSpin hand-held nutrunners



PROGRAM SELECTOR SWITCH

On request

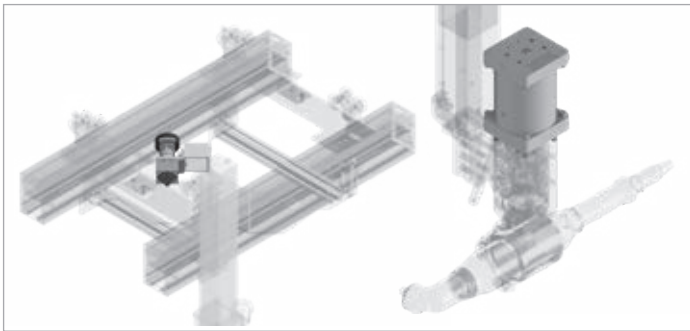

BRAKES

On request



HANDLING DEVICES

On request

Angle compensation function

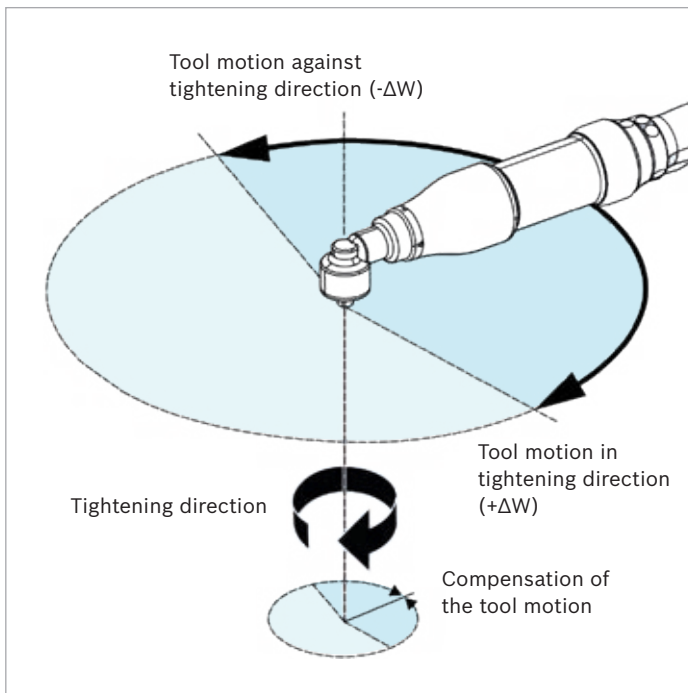

FUNCTIONALITY

- ▶ Functionality available for all new ErgoSpin hand-held nutrunners
- ▶ Compensation of worker movement with triaxial sensors in real-time
- ▶ Measurement and output of the programmed actual angle of turn values
- ▶ Improvement of the joint quality especially in connection with angle-controlled target functions
- ▶ No alignment of the Bosch gyro sensor required thanks to triaxial sensor system



LICENSE STICK

The angle compensation function is available for the Rexroth Tightening System 350 from software version V2.500 upwards. Activating the angle compensation function requires a license, which is available on a license stick. Each license stick contains exactly one license for a tightening channel. The license stick must be plugged into the corresponding control unit (interface X3U1, X3U2) for the function to be executed.

FREE DEMO PERIOD

The angle compensation function can be tested for a maximum period of 30 days without licensing. Activation is only possible once for each channel on each controller.

NOTE

It is possible to make changes to the angle head setting. Information on this can be found in the configuration description.

LICENSE STICK

| Code | | Order no. |
|--------|-------------|---------------|
| LS-ESG | 1 x License | 0 608 830 307 |

Nexo – intelligent cordless nutrunners

Rexroth intelligent cordless nutrunners join wireless technology with all the advantages of the proven ErgoSpin hand-held nutrunner for all category A safety-critical tightening jobs in accordance with VDI 2862: Direct measurement of control and monitoring values and the storing of the fastening results for record keeping purposes.



- ▶ Fits easily into the existing infrastructure of any production environment
- ▶ Integrated controller
- ▶ Direct communication between the line PLC and the data collection server
- ▶ Protection class: IP40

Nexo cordless nutrunner

NXP pistolgrip nutrunner



- ▶ Working range 1.8–12 Nm
- ▶ Max. output drive speed 880 rpm
- ▶ Suitable for safety-critical tightening jobs in accordance with VDI/VDE 2862

FEATURES

- ▶ For troublefree working at hard-to-reach tightening positions
- ▶ Ergonomic design and maximum freedom of movement
- ▶ Graphic display: direct values of the tightening results, program selection, and process information
- ▶ Process reliability even without a connection to the WiFi network

| Working range | Max. output drive speed | Tool mount | Weight without battery ¹ | Installation length without battery ¹ | Code | Order no. |
|---------------|-------------------------|-------------------------|-------------------------------------|--|-----------------------------|------------|
| Nm | rpm | | kg | mm | | |
| 1.8–12 | 880 | 1/4" quick-change chuck | 1.34 | 237 | NXP012QD-36V | 0608842005 |
| 1.8–12 | 880 | 1/4" quick-change chuck | 1.34 | 237 | NXP012QD-36V-B ² | 0608842010 |

NOTE

Supply of Nexo cordless nutrunner without battery pack.
For slide-in battery pack see page 106.

¹ Weight of battery: 0.7 kg
Length of battery: 86 mm

² With integrated barcode scanner

Nexo cordless nutrunner

NXA right-angle nutrunner



- ▶ Working range 3–65 Nm
- ▶ Max. output drive 850 rpm
- ▶ Suitable for safety-critical tightening jobs in accordance with VDI/VDE 2862

FEATURES

- ▶ With slim angle head for high accessibility
- ▶ Graphic display: direct values of the tightening results, program selection, and process information
- ▶ Process reliability even without a connection to the WiFi network

| Working range Nm | Max. output drive speed rpm | Tool mount | Weight without battery ¹ kg | Installation length without battery ¹ mm | Code | Order no. |
|---------------------|-----------------------------------|-------------------|--|---|----------------------------|------------|
| 3–11 | 850 | 3/8" square drive | 1.56 | 442 | NXA011S-36V | 0608842011 |
| 3–11 | 850 | 3/8" square drive | 1.56 | 442 | NXA011S-36V-B ² | 0608842012 |
| 3–15 | 600 | 3/8" square drive | 1.56 | 442 | NXA015S-36V | 0608842001 |
| 3–15 | 600 | 3/8" square drive | 1.56 | 442 | NXA015S-36V-B ² | 0608842006 |
| 6–30 | 310 | 3/8" square drive | 1.99 | 534 | NXA030S-36V | 0608842002 |
| 6–30 | 310 | 3/8" square drive | 1.99 | 534 | NXA030S-36V-B ² | 0608842007 |
| 10–50 | 185 | 3/8" square drive | 2.03 | 534 | NXA050S-36V | 0608842003 |
| 10–50 | 185 | 3/8" square drive | 2.03 | 534 | NXA050S-36V-B ² | 0608842008 |
| 13–65 | 135 | 3/8" square drive | 2.03 | 534 | NXA065S-36V | 0608842013 |
| 13–65 | 135 | 3/8" square drive | 2.03 | 534 | NXA065S-36V-B ² | 0608842014 |

¹ Weight of battery: 0.7 kg; length of battery: 86 mm

² With integrated barcode scanner

NOTE

Supply of Nexo cordless nutrunner without battery pack.
For slide-in battery pack see page 106.

Nexo cordless nutrunner

NXV VarioLine nutrunner



- ▶ Working range basic machine 1.8–12 Nm
- ▶ Working range with angle head 3–15 Nm
- ▶ Max. output drive of basic machine 880 rpm
- ▶ Max. output drive with angle head 600 rpm
- ▶ Suitable for safety-critical tightening jobs in accordance with VDI/VDE 2862

FEATURES

- ▶ With slim angle head for high accessibility
- ▶ Graphic display: direct values of the tightening results, program selection, and process information
- ▶ Process reliability even without a connection to the WiFi network

| Working range Nm | Max. output drive speed rpm | Tool mount | Weight without battery ¹ kg | Installation length without battery ¹ mm | Code | Order no. |
|--------------------------|-----------------------------------|--|--|---|----------------------------|------------|
| 3–15/1.8–12 ² | 600/880 ² | Basic machine with an output with thread and pin for the attachment of special output drives | 1.56/1.35 ² | 442 | NXV012T-36V | 0608842015 |
| 3–15/1.8–12 ² | 600/880 ² | | 1.56/1.35 ² | 442 | NXV012T-36V-B ³ | 0608842016 |

¹ Weight of battery: 0.7 kg; length of battery: 86 mm

² Values without output drive

³ With integrated barcode scanner

NOTES

Supply of basic machine with angle head.
Supply of Nexo cordless nutrunner without battery pack.
For slide-in battery pack see page 106.

Nexo Angle heads



| Code | Suitable for | Tool mount | Weight kg | Max. torque* Nm | Gear ratio | Avg. efficiency | Order no. |
|-----------|----------------|--------------|--------------|-----------------------|---------------|--------------------|---------------|
| NXAH11-15 | NXA011S-36V/-B | 3/8" | 1.56 | 15 | 1.4 | 0.94 | 0 608 843 022 |
| | NXA015S-36V/-B | square drive | | | | | |
| NXAH30 | NXA030S-36V/-B | 3/8" | 1.56 | 30 | 5.25 | 0.94 | 0 608 843 023 |
| | | square drive | | | | | |
| NXAH50-65 | NXA050S-36V/-B | 3/8" | 1.56 | 65 | 6.363636 | 0.94 | 0 608 843 024 |
| | NXA065S-36V/-B | square drive | | | | | |

* Value refers to angle head

Nexo Accessories and extensions



MOUNTING AID FOR ANGLE HEADS

| Code | Suitable for | Order no. |
|------|--------------|---------------|
| ESWM | NXA030S-36V | 3 608 876 473 |
| | NXA050S-36V | |
| | NXA065S-36V | |

**PROTECTIVE CAP FOR ANGLE HEADS**

| Code | Suitable for | Quantity | Order no. |
|---------|--------------|----------|---------------|
| NXAPAH2 | NXA030S-36V | 5 | 0 608 843 015 |
| | NXA050S-36V | | |
| | NXA065S-36V | | |

**PROTECTIVE CAP FOR ANGLE HEADS**

| Code | Suitable for | Quantity | Order no. |
|---------|--------------|----------|---------------|
| NXAPAH1 | NXA011S-36V | 5 | 0 608 843 016 |
| | NXA015S-36V | | |

**PROTECTIVE INSULATION FOR BATTERY ASSEMBLY**

| Code | Suitable for | Tool mount | Max. torque | Order no. |
|---------|--------------|-------------------------|-------------|---------------|
| NXPP012 | NXP12QD-36V | 1/4" quick-change chuck | 12 Nm | 0 608 843 012 |

**PROTECTIVE INSULATION FOR BATTERY ASSEMBLY**

| Code | Suitable for | Tool mount | Max. torque | Order no. |
|---------|--------------|-------------------|-------------|---------------|
| NXAP030 | NXA030S-36V | 3/8" square drive | 30 Nm | 0 608 843 011 |
| | NXA050S-36V | | | |
| | NXA065S-36V | | | |

Nexo – accessories and extensions



SLIDE-IN BATTERY PACK

| Code | Quantity | Order no. |
|------------|----------|------------|
| NX-BP2-36V | 1 | 0608843019 |



SIMPLE CHARGER

| Code | Voltage | Order no. |
|----------|----------------------|------------|
| NX-BC36V | 100V-240V (~50-60Hz) | 0608843002 |

Battery charging cabinets for Rexroth slide-in battery packs on request



PROGRAMMING ADAPTER*

| Code | Order no. |
|-------|------------|
| NX-A3 | 0608843021 |

* Adapter supplied without Ethernet cable



MICRO SD CARD

| Code | Order no. |
|-------|------------|
| NX-SD | 0608843005 |



HOLDER FOR RIGHT-ANGLE NUTRUNNERS

| Code | Order no. |
|------|------------|
| ESAT | 3608876626 |

On request with sensors for tool detection



HOLDER FOR PISTOLGRIP NUTRUNNERS

| Code | Order no. |
|------|------------|
| NXPT | 0608843008 |

Note: Cannot be used for pistolgrip nutrunners with protective insulation for battery assembly



TURNING SUSPENSION FOR RIGHT-ANGLE NUTRUNNERS

| Code | Order no. |
|-------|------------|
| NXAMT | 0608843003 |

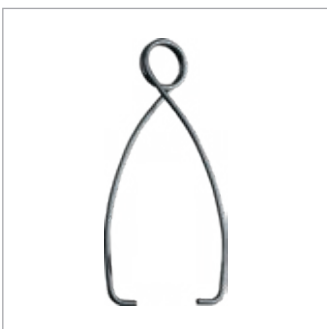

SUSPENSION FOR PISTOLGRIP NUTRUNNERS

| Code | Order no. |
|------|------------|
| NXPB | 0608843004 |

Nexo – accessories and extensions



EXTRA GRIP FOR PISTOLGRIP NUTRUNNERS

| Code | Order no. |
|------|------------|
| NXPH | 0608843009 |

Note: Cannot be used for pistolgrip nutrunners with protective insulation for battery assembly.



ASSORTED COLORED RINGS

| Code | Quantity | Order no. |
|------|-----------------------------|------------|
| NX-R | 21 (3 pieces of each color) | 0608843010 |



NEXO BRACKET FOR SUPPORT SYSTEMS (E. G. POSITIONING SENSORS)

| Code | Quantity | Order no. |
|-------|----------|------------|
| NX-HD | 2 | 0608843018 |



ACCESS POINT*

| Code | Order no. |
|-----------|------------|
| NX-ACCESS | 0608843007 |

* Without power supply unit.

Nexo

Browser-based operating software NEXO-OS

- ▶ Easy set-up as additional software installation is not necessary. Operating software can be used without local installation.
- ▶ Independence from end devices provides complete flexibility. Access to the browser-based software is not dependent on operating system nor end device.
- ▶ You can access the Nexo software by using any web-browser enabled device.
- ▶ Easy to learn, easy to use: Programming of individual tightening tasks is simple via the intuitive graphic user interface.
- ▶ Scalable user rights



Control and power electronics

The hardware platform is based on cutting-edge technology and thus ensures investment security. It has been specially developed for industrial applications. The system box and compact system fully comply with the IP54 protection class.



- ▶ Compact and powerful
- ▶ Secure and fast commissioning
- ▶ Sturdy: IP54
- ▶ Combination of tightening spindles/ErgoSpin
- ▶ Well arranged control and display elements
- ▶ Flexible connection to control and archive systems
- ▶ High process reliability due to internal self-diagnostics



Maximum flexibility in controller configuration – here are just some of the many options:

1

One nutrunner – multiple nutrunners?

COMPACT SYSTEM OR MODULAR SYSTEM

- ▶ 1 tightening channel = CS351 Compact System page 112
- ▶ 2 to 40 tightening channels = 350 Modular System page 118

2

350 Modular System – where to store the system components?

BT CARD RACK OR SB SYSTEM BOX

- ▶ The card rack is designed for installation in a control cabinet.
- ▶ Tightening systems without control cabinets are possible with the system box.

3

Universal communication – the KE communication unit

CONFIGURATION OF THE FIRST BT CARD RACK/FIRST SB SYSTEM BOX

- ▶ VM power supply module
- ▶ KE communication unit
- ▶ SE control units Max. 3 SE per BT/SB
- ▶ LTS/LTE servo amplifiers (tightening spindle/ErgoSpin respectively) Max. 5 LTS/LTE per BT/SB

4

1, 2, 3... and many more

CONNECTING MULTIPLE BT CARD RACKS/SB SYSTEM BOXES

- ▶ Multiple BT/SB are connected to NK network couplers. Configuration from 2nd BT/SB:
- ▶ No KE is required from the 2nd BT/SB upwards. Max. 3 SE pro BT/SB
- ▶ Another LTS/LTE can be inserted in its position. Max. 6 LTS/LTE per BT/SB

CS351 Compact System

The operating and display units, as well as the connections, are arranged in a userfriendly, modern, and convincing design. The clear structure of the CS351 allows intuitive operation without any complicated configuration.

The housing, which is not larger than a minitower, fully complies with protection class IP54. Its compact interior combines power electronics and Ethernet-based bus systems with the new highperformance 350 control generation.

FEATURES

- ▶ Compact and powerful
- ▶ Clear system design
- ▶ Secure and fast commissioning
- ▶ Tightening results at a glance, including curves
- ▶ Clearly arranged control and display elements
- ▶ Sturdy: IP54, EMC severity level IV
- ▶ USB and Ethernet-based bus systems
- ▶ Flexible adaptation to new tasks





Hinged, removable interface cover

Easy-to-access USB programming interface

Future-proof expansion through interface modules

GFCI

Cable duct

Connection cable

High-quality aluminum housing

Suspension strip top and bottom for easy assembly

On/off switch

Mains connection for 120 V/230 V

Cable duct

CS351 Compact System – model variants



COMPACT SYSTEM CS351...-G... HIGH-QUALITY TFT WITH TOUCH SCREEN AND LARGE VIEWING ANGLE

- ▶ Resolution: 640x480
- ▶ Display size: 6.5 inches
- ▶ Actual value display
- ▶ Tightening graph display
- ▶ Parameter changes
- ▶ Ethernet on board
- ▶ Tightening program selection

COMPACT SYSTEM CS351...-D... DISPLAY VERSION WITH DVI INTERFACE

- ▶ Actual value display
- ▶ Connection to external DVI monitor and input unit
- ▶ Ethernet on board

| Compact System for | Code | Weight kg | Order no. |
|--------------------|-------------|--------------|---------------|
| ErgoSpin | CS351E-G | 9.7 | 0 608 830 258 |
| | CS351E-D | 9.5 | 0 608 830 257 |
| | CS351E-G IL | 9.7 | 0 608 830 275 |
| | CS351E-D IL | 9.5 | 0 608 830 274 |
| | CS351E-D NK | 9.9 | 0 608 830 281 |
| Tightening spindle | CS351S-G | 9.7 | 0 608 830 255 |
| | CS351S-D | 9.5 | 0 608 830 254 |
| | CS351S-G IL | 9.7 | 0 608 830 277 |
| | CS351S-D IL | 9.5 | 0 608 830 276 |
| | CS351S-D NK | 9.9 | 0 608 830 282 |

Note: For cable selection, see "Rexroth cables" from page 136.

CS351

- ▶ Dimensions (H x W x D): 358 x 210 x 253 mm
- ▶ Very easy suspension, even in tight areas
- ▶ Hinged, removable interface cover
- ▶ Highly flexible and future-proof due to interface modules
- ▶ IP54 protection class
- ▶ 120 V* and 230 V power supply
- ▶ Mains connection cable for 230 V included in the scope of delivery
- ▶ Motor stop interface
- ▶ RCD with CS351E-...
- ▶ Exchange connection cable – without tools

* The speed of size 5 motors is 15% lower with an operating voltage of 120 V than with an operating voltage of 230 V. The torque of the size 5 motors is 30% lower with an operating voltage of 120 V than with an operating voltage of 230 V.

CS351...IL

- ▶ Integrated logic
- ▶ Flexible programming according to IEC 61131-3
- ▶ Easy automation for the entire tightening process

CS351...NK

- ▶ Can be connected as an additional tightening channel to the KE350/KE350G IL via the network coupler cable
- ▶ Complete system bus diagnosis
- ▶ Central data output via the KE350/KE350G IL

NOTE

You can find the technical data for the Rexroth control electronics in the assembly instruction:

www.boschrexroth.com/tightening.

CC-CS351 Compact System for CC-ErgoSpin



- ▶ For CC-ErgoSpin hand-held nutrunner control
- ▶ Use in function and un-critical tightening applications according to classes B and C of VDI/VDE 2862

FEATURES

- ▶ Secure and fast commissioning
- ▶ Tightening results at a glance
- ▶ Sturdy: IP54, EMC severity level IV
- ▶ USB and Ethernet interface
- ▶ Clear system design
- ▶ Flexible adaptation to new tasks
- ▶ Clearly arranged control and display elements
- ▶ System not fieldbus capable; 24V I/O

NOTE

You can find the technical data for the Rexroth control electronics in the assembly instruction:

www.boschrexroth.com/tightening.

| Compact System for | Code | Weight kg | Order no. |
|--------------------|-------------|--------------|---------------|
| CC-ErgoSpin | CC-CS351E-D | 9.5 | 0 608 830 289 |

Slots and connections

To ensure that the tightening system optimally matches your control environment today and in the future, it features three slots for interface modules, which are covered with dummy panels at the factory.

The CS351E-D... and CS351S-D... Compact Systems have an additional DVI interface to connect an external monitor and a corresponding USB feedback channel.

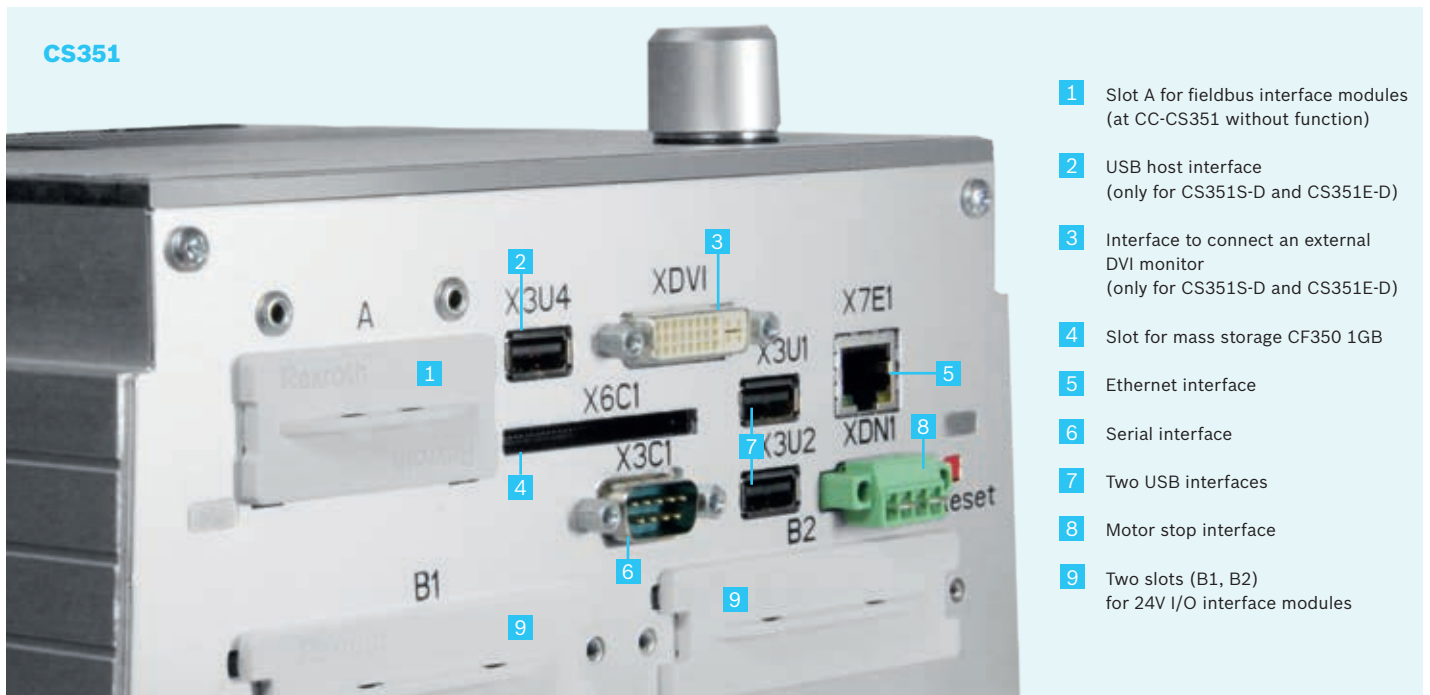

| Slot | Fieldbus / description | Code | Order no. | Page |
|---------------|------------------------|-----------|--------------------|---------|
| A | PROFIBUS DP | IMpdp | 0 608 830 266 | 134 |
| | DeviceNet | IMdev | 0 608 830 267 | 134 |
| | PROFINET IO | IMpnio | 0 608 830 272 | 134 |
| | PROFINET IO | IMpnio2 | 0 608 830 312 | 134 |
| | EtherCat | IMecat | 0 608 830 302 | 135 |
| | Ethernet/IP | IMenip | 0 608 830 271 | 135 |
| | Ethernet/IP | IMenip2 | 0 608 830 313 | 135 |
| | Modbus TCP | IMmtcp | 0 608 830 273 | 135 |
| B | 24V I/O interface | IM24V | 0 608 830 259 | 135 |
| X6C1 | Mass storage | CF350 1GB | 0 608 830 318 | 129 |
| XDAC1 / XDAC2 | Network coupler cable | NKL0.6 | 3 608 877 369 | 139/143 |
| | | NKL002 | 3 608 877 370 | |
| | | NKL005 | 3 608 877 371 | |
| | | NKL010 | 3 608 877 372 | |
| | | NKLF* | 3 608 877 373 /... | |

Note: For cable selection, see "Rexroth cables" from page 136.

Modular System



- ▶ Multi-channel tightening system
- ▶ Can be upgraded to up to 40 tightening channels
- ▶ Combination of tightening spindles/ErgoSpin
- ▶ Uncomplicated programming
- ▶ Either in card rack or system box
- ▶ Convenient installation thanks to modularity



The splash-proof SB356 system box is intended for operation without a control cabinet in an industrial environment.



The BT356 card rack is intended for installation in control cabinets.

The SB356 system box and the BT356 card rack, made from durable stainless steel, are required in the modular system to support the control and power electronics.

Besides the VM350 power supply module, the BT/SB can also be equipped with up to six tightening channels. The tightening channels comprise an SE352 or SE352M control unit that controls up to two LTS350D servo amplifiers for tightening spindles or LTE350D servo amplifiers for ErgoSpin hand-held nutrunners. Mixed operation of tightening spindles and ErgoSpin on a SE352 or SE352M is possible at any time.

The KE350 or KE350G IL communication unit is responsible for internal and external system communication. It is inserted in the outermost BT/SB slot, instead of the sixth servo amplifier.

When the KE350 or KE350G IL is inserted in the first SB or the first BT, up to 16 BT/SB can be connected via the NK350 or NK350S network coupler and NKL network coupler cables.

The flexibly programmable logic integrated in the KE350G IL is in compliance with IEC 61131-3 and gives the user countless automation options for the entire tightening process.

Unused slots must be closed off with dummy panels for safety reasons and for reasons of electromagnetic compatibility.

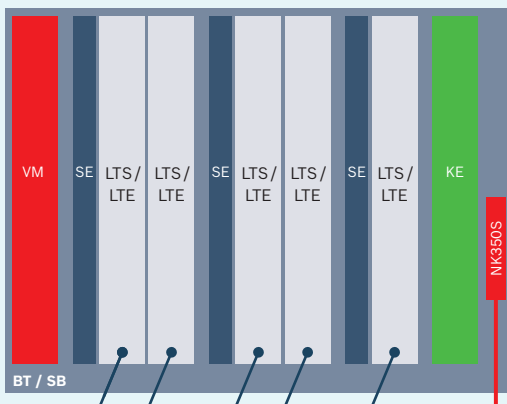

1 CARD RACK/SYSTEM BOX FOR UP TO 5 TIGHTENING CHANNELS AND COMMUNICATION UNIT

| | |
|------------|---|
| BT | Card rack |
| SB | System box |
| VM | Power supply module |
| KE | Communication unit |
| SE | Control unit |
| LTS | Servo amplifier for tightening spindles |
| LTE | Servo amplifier for ErgoSpin hand-held nutrunners |
| NK | Network coupler |

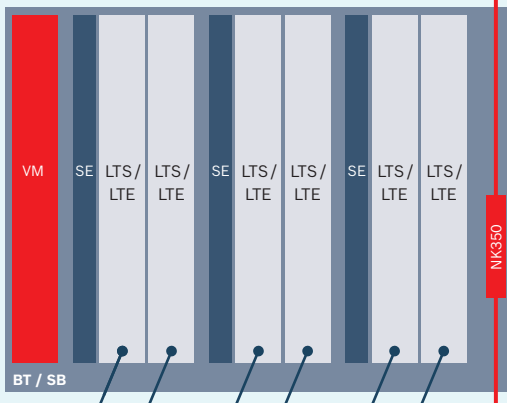

COMBINATION OF MULTIPLE CARD RACKS/SYSTEM BOXES FOR UP TO 40 TIGHTENING CHANNELS

- ▶ Max. 6 tightening channels per BT/SB
- ▶ Max. total length of all network coupling cables: 150 m
- ▶ Max. length of one network coupling cable: 50 m
- ▶ Control of max. 40 tightening channels with one KE350 (up to 16 network couplers)
- ▶ Reliable system bus with diagnostics capabilities
- ▶ Multi-colored LED on network coupler for network status display
- ▶ Type and timing of the incoming signals are processed and supplied to the nearest NK350.

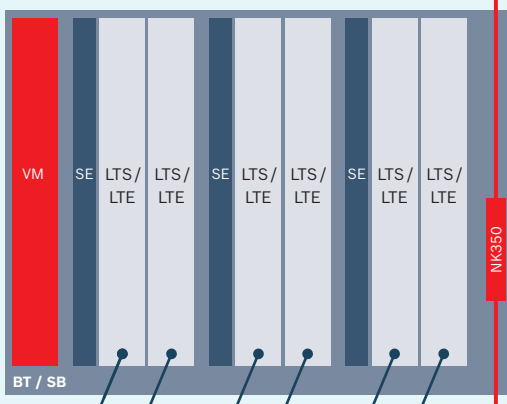

SB356 System Box



- ▶ To accommodate the control and power electronics for up to six tightening channels
- ▶ IP54 protection class

FEATURES

- ▶ Designed for operation without control cabinet
- ▶ For networking of up to 16 BT/SB (with NK350 or NK350S network coupler and NKL network coupler cables)
- ▶ Compact dimensions
- ▶ High packing density
- ▶ Combination of hand-held nutrunner and stationary spindle possible (except CC-ErgoSpin)
- ▶ Fast replacement of control and power components

| Code | Dimensions W x H x D mm | Weight (empty) kg | Order no. |
|-------|----------------------------|----------------------|------------|
| SB356 | 510x600x470 | 55 | 0608830251 |

| SB356 system box configuration | Up to 5 channels, 1 x SB356 | Up to 40 channels, multiple SB356 | | Info on page |
|---------------------------------|--------------------------------|--------------------------------------|----------------------------------|--------------|
| | SB356 system box | First SB356 system box | Additional SB356 system boxes | |
| | Number of slots | Number of slots | Number of slots per SB356 | |
| VM 350 power supply module | 1 | 1 | 1 | 125 |
| KE350 communication unit | 1 | 1 | – | 128 |
| SE352/SE352M control unit | 3 | 3 | 3 | 126 |
| LTS350D/LTE350D servo amplifier | 5 | 5 | 6 | 127 |
| Tightening channels | 5 | 5 | 6 | 123/132 |
| NK350S / NK350 network coupler | – | 1 x NK350S | 1 x NK350 | 129 |





DUMMY PANELS

Empty slots are closed off with dummy panels.

Two versions are available: BP351 closes off a KE or LT slot; BP352 simultaneously closes off an SE and an LT slot.



NON-STANDARD LOCKS FOR SB356

| Code | Order no. |
|---|------------|
| E1 | 3608874026 |
| E16 | 3608874109 |
|  3 mm* | 3608874027 |
|  Fiat | 3608874028 |
|  Daimler | 3608874029 |
|  7 mm | 3608874030 |

* Standard design

Note: You can find the technical data for the Rexroth control electronics in the assembly instruction: www.boschrexroth.com/tightening.

REQUIRED NUMBER OF DUMMY PANELS FOR THE BT356 CARD RACK WITH KE350

| Number of channels | BP351 3608878058 | BP352 3608878060 |
|--------------------|---------------------|---------------------|
| 1 | 2 | 2 |
| 2 | 1 | 2 |
| 3 | 1 | 1 |
| 4 | 0 | 1 |
| 5 | 0 | 0 |

BT356 card rack



- ▶ To accommodate the control and power electronics for up to six tightening channels
- ▶ For assembly in the control cabinet or to the mounting plate using mounting brackets

FEATURES

- ▶ For networking of up to 16 BT/SB (with NK350 or NK350S network coupler and NKL network coupler cables)
- ▶ Compact dimensions

| Code | Dimensions W x H x D mm | Weight (empty) kg | Order no. |
|-------|----------------------------|----------------------|------------|
| BT356 | 310x483x381 | 7 | 0608830253 |

| BT356 system box configuration | Up to 5 channels 1 x BT356 | Up to 40 channels Multiple BT356 | | Info on page |
|---------------------------------|-------------------------------|-------------------------------------|--------------------------------|--------------|
| | BT356 card rack | First BT356 card rack | Additional BT356 card racks | |
| | Number of slots | Number of slots | Number of slots per BT356 | |
| VM 350 power supply module | 1 | 1 | 1 | 122 |
| KE350 communication unit | 1 | 1 | – | 122 |
| SE352/SE352M control unit | 3 | 3 | 3 | 122 |
| LTS350D/LTE350D servo amplifier | 5 | 5 | 6 | 122 |
| Tightening channels | 5 | 5 | 6 | 122/132 |
| NK350S / NK350 network coupler | – | 1 x NK350S | 1 x NK350 | 122 |

Note: You can find the technical data for the Rexroth control electronics in the assembly instruction: www.boschrexroth.com/tightening.

Permissible configuration with BT356/SB356 Servo amplifiers

PLANNING ASSISTANCE: SYSTEM BOX AND CARD RACK CONFIGURATION

One tightening channel consists of the following components:

- ▶ ErgoSpin hand-held nutrunner or tightening spindle
- ▶ Connection cable
- ▶ Control unit
- ▶ Servo amplifier

The KE350 or KE350G IL communication unit is responsible for internal and external system communication. If the appropriate control and power electronics are installed, both stationary tightening spindles and ErgoSpin hand-held nutrunners can be connected to and operated on the SB356 system box and the BT356 card rack. Mixed operation of stationary tightening spindles and ErgoSpin hand-held nutrunners on a system box or a card rack is possible at any time.

Not every configuration is permitted due to the fact that the power consumption of the servo amplifier depends on the type of tightening spindle or ErgoSpin hand-held nutrunner that is connected. The maximum permissible peak current for up to six tightening channels in the card rack or system box is 140 A. This is why you may only install components with a power consumption that does not exceed a total of 140 A.

TOTAL POWER CONSUMPTION ≤ 140 A (TIGHTENING SPINDLES + ERGOSPIN)

- ▶ Up to 40 tightening channels by combining multiple card racks/system boxes
- ▶ Maximum system reliability thanks to 100% digital data transfer
- ▶ Integrated system for hand-held nutrunners and stationary technology
- ▶ Scalable and open for extensions

| Max. power consumption Ampere | Stationary tightening spindles | | | | ErgoSpin hand-held nutrunners | | | |
|---|---|---|---|---|---|--|---|---|
| | 45 A | 28 A | 14 A | 7 A | 50 A | 33 A | 18 A | 11 A |
| Tightening spindle or ErgoSpin hand-held nutrunner | LTS350D servo amplifier + Tightening spindle size 5 | LTS350D servo amplifier + Tightening spindle size 4 | LTS350D servo amplifier + Tightening spindle size 3 | LTS350D servo amplifier + Tightening spindle size 2 | LTE 350D servo amplifier + ErgoSpin hand-held nutrunners ESA100S ESA150S ESA220S ESV073 ESV146 | LTE 350D servo amplifier + ErgoSpin hand-held nutrunners ESA040... ESA056... ESA065... ESA075... ESM025... ESM035... ESV025 ESV050 | LTE 350D servo amplifier + ErgoSpin hand-held nutrunners ESA030... | LTE 350D servo amplifier + ErgoSpin hand-held nutrunners ESA013... ESM012QD ESV005 ESV012 |

EXAMPLE: WHEEL BOLTS



In this example, five wheel bolts on each side of the vehicle are tightened to 130 Nm using size 4 tightening spindles.

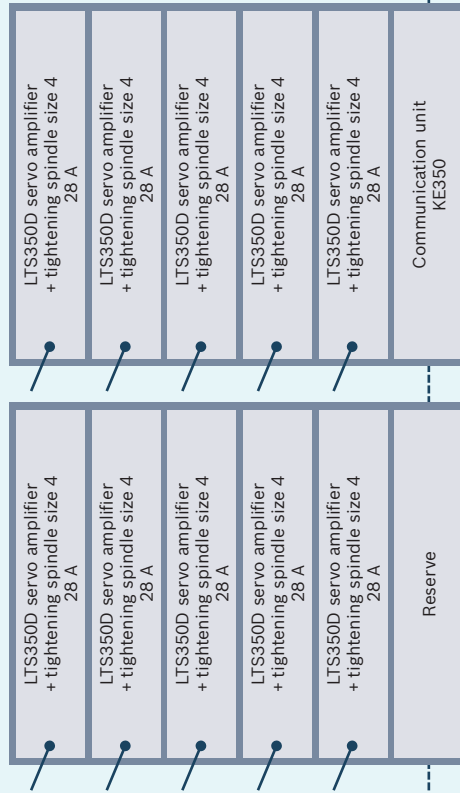

Ethernet connection

BT/SB power consumption
 $5 \times 28 \text{ A} = 140 \text{ A} (\leq 140 \text{ A})$

Up to 5 tightening spindles can be operated on the first system box/first card rack.

Networking with network coupler

System boxes and card racks can be connected using network couplers.

EXAMPLE: MOTOR CONNECTION



In this example, the camshaft bearing cap and the cylinder head are each tightened to the motor with double nutrunners (size 3 and 4 tightening spindles) with 15 Nm and 130 Nm respectively. In addition, small parts are tightened with rightangle and pistolgrip nutrunners.

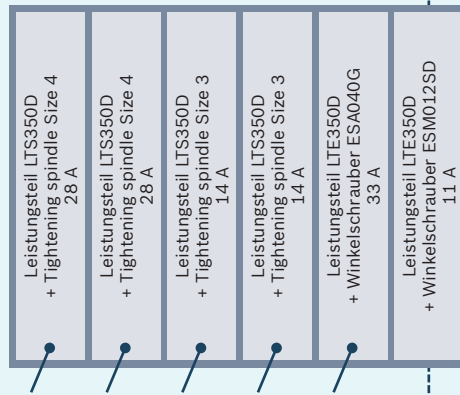

Networking with network coupler

BT/SB power consumption
 $2 \times 28 \text{ A} + 2 \times 14 \text{ A} + 33 \text{ A} + 11 \text{ A} = 128 \text{ A} (\leq 140 \text{ A})$

Mixed operation with up to six tightening channels is possible on an SB356 system box or a BT356 card rack.

VM350 power supply module



- ▶ Used to supply power to all the slots in the BT356 card rack or in the SB356 system box.

| Code | Order no. |
|-------|---------------|
| VM350 | 0 608 750 110 |

FEATURES

- ▶ One VM350 is required for each card rack or system box.
- ▶ 24 V interface (X1S1) on the front to ensure external power supply of the KE, SE, and LT in event of power failure or if the supply is switched off
- ▶ Integrated E-stop functionality (performance level d)
- ▶ 24 V power supply for external consumers

SE352 and SE352M control units



- ▶ To control and monitor the tightening process of up to two independent tightening channels per control unit
- ▶ For hand-held nutrunners and stationary spindles

| Code | Order no. |
|--------|---------------|
| SE352 | 0 608 830 262 |
| SE352M | 0 608 830 263 |



Example layout
SE352M with IM24V

FEATURES

- ▶ Carries out system diagnosis and monitors all individual components of a tightening channel
- ▶ Tightening processes and rework strategies are simply and flexibly programmed via the BS350 operating system.
- ▶ Automatic recognition of individual components enables fast and secure start-up.
- ▶ The SE352M control unit is equipped with one free slot (on delivery, the SE352M control unit slot is sealed with a cover). An IM24V interface module can be inserted in this slot for communication with superior controllers.
- ▶ USB port interface used for the insertion of the license stick for the angle compensation functionality.

Servo amplifiers for tightening spindles and ErgoSpin hand-held nutrunners



- ▶ For EC motor control
- ▶ Integrated motor contactor

| Code | | Order no. |
|---------|---------------------------------------|---------------|
| LTS350D | For all tightening spindles | 0 608 750 125 |
| LTE350D | For all ErgoSpin hand-held nutrunners | 0 608 750 126 |

FEATURES

- ▶ The control parameters are transmitted digitally from the SE control unit to the LT servo amplifier
- ▶ LC display for tightening results and system information
- ▶ Integrated E-stop functionality (performance level d)

KE350 and KE350G IL communication units



- ▶ To coordinate individual control units and organize the interfaces with external systems (e.g. PLC or central computer)

| Code | Order no. |
|-----------|---------------|
| KE350 | 0 608 830 264 |
| KE350G IL | 0 608 830 265 |

FEATURES

- ▶ System-internal communication with the control units occurs via a standard bus system
- ▶ One serial interface and three free slots for connecting to external systems
- ▶ Various interface modules are available for controlling and data communication
- ▶ On delivery, the slots in the KE350 and KE350G IL communication units are closed off with covers
- ▶ Integrated logics in KE350G IL: flexible programming in compliance with IEC 61131 3, enables countless automation options for the entire tightening process

Accessories for control and power electronics



NETWORK COUPLER

| Code | Order no. |
|---------|---------------|
| NK350 | 3 608 877 367 |
| NK350S* | 3 608 877 368 |

*with integrated 24V power supply for the system bus



DUMMY PANELS

| Code | Order no. |
|-------|---------------|
| BP351 | 3 608 878 058 |
| BP352 | 3 608 878 060 |



MOUNTING BRACKET SET FOR BT356

| Code | Order no. |
|--------|------------|
| BTW356 | 3608878116 |



MASS STORAGE

| Code | Memory size | Order no. |
|----------|-------------|------------|
| CS350 1G | 1 GB | 0608830318 |

Control cabinets



Ask us – we would be happy to advise you! With the BT356 card rack, the Rexroth modular system is ideally equipped for use in control cabinets. Benefit from our experience: we can offer you advice on which control cabinet is best suited to your production environment and how control and power electronics can be integrated easily.

We provide control cabinets manufactured to your requirements as well as control cabinets in the following standard dimensions:

- ▶ 1,800x600x500 mm (H x W x D) for up to 18 tightening channels or 17 tightening channels plus KE350 / KE350G IL for tightening spindles in sizes 2, 3, and 4 (size 5 and mixed configurations available on request)
- ▶ 2,000x600x500 mm (H x W x D) for up to 24 tightening channels or 23 tightening channels plus KE350 / KE350G IL for tightening spindles in sizes 2 and 3 (sizes 4 and 5 and mixed configurations available on request)

The standard delivery color is RAL 7032. Other options, e.g. other colors, are available on request.

CONTROL CABINETS

On request



RACK FOR 2 SYSTEM BOXES

On request



Open and flexible: Interface modules

The interface modules are the connection between the tightening systems and the process controls. Today, Rexroth offers customers all common standards of fieldbuses such as PROFIBUS and DeviceNet as well as Ethernet-based fieldbus systems.



- ▶ Perfect network connection
- ▶ Connection between the tightening system, and the company's IT
- ▶ All standard fieldbuses
- ▶ Open, modular system concept for future standards

CS351**1**

X6C1 slot for CF350
1GB mass storage

2

Two slots (B1, B2)
for 24V I/O interface
modules

3

Slot A for fieldbus
modules

4

Ethernet on board





**KE350 / KE350G IL****1****2****3****4**





To ensure that the tightening system optimally matches your control environment today and in the future, free slots for interface modules are included on the CS351 Compact System, the KE350, and the KE350G IL.

On delivery, the slots are closed off with covers.

CS351...-D and KE350G IL have an additional DVI interface to connect an external monitor and a corresponding USB feedback channel.

Interface modules

| | Slot | Fieldbus / designation | Code | Order no. | Description |
|---|------|------------------------|---------|---------------|--|
|  | A | PROFIBUS DP | IMpdp | 0 608 830 266 | <ul style="list-style-type: none"> ▶ Data transfer via I/O level, e.g. for PLC functionality ▶ Insertion in the A slot of the KE350... or the CS351... ▶ Occupies a 400 byte address space on the fieldbus, which can be adjusted from 16I/16O points (2 bytes) to 512 I/512O points (128 bytes), as well as 0-64 bytes ID code and 0-242 bytes data ▶ The logical assignment of the control signals is set using the BS350 operating system |
|  | A | DeviceNet | IMdev | 0 608 830 267 | <ul style="list-style-type: none"> ▶ Data transfer via I/O level, e.g. for PLC functionality ▶ Insertion in the A slot of the KE350... or the CS351... ▶ Occupies a 512 byte address space on the fieldbus, which can be adjusted from 16 I/16O points (4 bytes) to 512 I/512O points (128 bytes), as well as a 0-64 bytes ID code ▶ The logical assignment of the control signals is set using the BS350 operating system |
|  | A | PROFINET IO | IMpnio | 0 608 830 272 | <ul style="list-style-type: none"> ▶ Complete PROFINET IO interface with IO device function (slave) ▶ Simple data transfer via I/O level ▶ Complies with the real-time classification (RT) of the PROFIBUS user organization |
|  | A | PROFINET IO | IMpnio2 | 0 608 830 312 | <ul style="list-style-type: none"> ▶ Complete PROFINET IO interface with IO device function (slave) ▶ Simple data transfer via I/O level ▶ Complies with the real-time classification (RT) of the PROFIBUS user organization ▶ KE: from 2 to 64 byte I/O, to 254 byte E-data, to 254 byte output data ▶ CS: from 2 to 8 byte I/O, to 64 Byte E-data, to 254 Byte output data ▶ Configurable into byte and multiple byte blocks ▶ Integrated switch for building networks in star, line or ring topology |

| | Slot | Fieldbus/ designation | Code | Order no. | Description |
|---|------|--------------------------|---------|---------------|---|
|  | A | EtherCat | IMecat | 0 608 830 302 | <ul style="list-style-type: none"> ▶ Enables coupling of the tightening system (slave) to EtherCat networks ▶ Data transfer possible via I/O level ▶ integrated switch for building networks in star, line or ring topology |
|  | A | Ethernet/IP | IMenip | 0 608 830 271 | <ul style="list-style-type: none"> ▶ Complete Ethernet/IP interface with adapter function (slave), includes all analog and digital components of a powerful Ethernet / IP connection ▶ Simple data transfer via I/O level ▶ Certified module tested for interoperability with leading Ethernet/IP scanner modules |
|  | A | Ethernet/IP | IMenip2 | 0 608 830 313 | <ul style="list-style-type: none"> ▶ Simple data transfer via I/O level ▶ Support for transfer rates of 10 Mbps or 100 Mbps ▶ The interface is designed as an 8-pin RJ45 socket ▶ Use of connector according to IEC 61158 ▶ Integrated switch for building networks in star, line or ring topology ▶ the LED NS shows status of the Ethernet ▶ Power is supplied directly through components of System 350 |
|  | A | Modbus TCP | IMmtcp | 0 608 830 273 | <ul style="list-style-type: none"> ▶ Complete ModbusTCP interface with server function (slave) ▶ Includes all analog and digital components of a powerful ModbusTCP interface connection ▶ Simple data transfer via I/O level |
|  | B | 24V I/O interface | IM24V | 0 608 830 259 | <ul style="list-style-type: none"> ▶ Enables control over the tightening system and output of 24 V status signals via a 24 V interface ▶ Insertion in a corresponding slot on the KE350 or KE350G IL or the SE352M control unit ▶ Provides 10 inputs and 13 outputs. The outputs are short circuit-proof and protected against reverse polarity ▶ Complies with DIN 19240 |

Rexroth cables: consistent, digital data transfer

Precise control and consistently reliable measurements for checking tightening results are the outstanding features of tightening systems from Rexroth. This level of precision requires data transport that is always error-free. This is why the tightening systems from Rexroth are equipped with fully digital data communication.

- ▶ Secure and reliable data transfer thanks to digital technology
- ▶ Maximum cable length of up to 100 meters enables flexible hall design
- ▶ Connection cables for tightening spindles are suitable for robot use
- ▶ Customer-specific cable lengths available





- ▶ Connection cables for joining tightening spindles with compact or modular systems
- ▶ Connection cables for joining hand-held nutrunners with compact or modular systems
- ▶ Extension cables for extending connection cables of tightening spindles with compact and modular systems
- ▶ Network coupler cables for connecting multiple modular systems
- ▶ Measurement transducer cables for connecting individual components of a tightening spindle
- ▶ USB programming cable for connecting a PC with compact or modular systems
- ▶ Mains connection cables for joining compact systems with a power socket (included in the scope of delivery in Europe)



Cables for tightening spindles with molded connectors

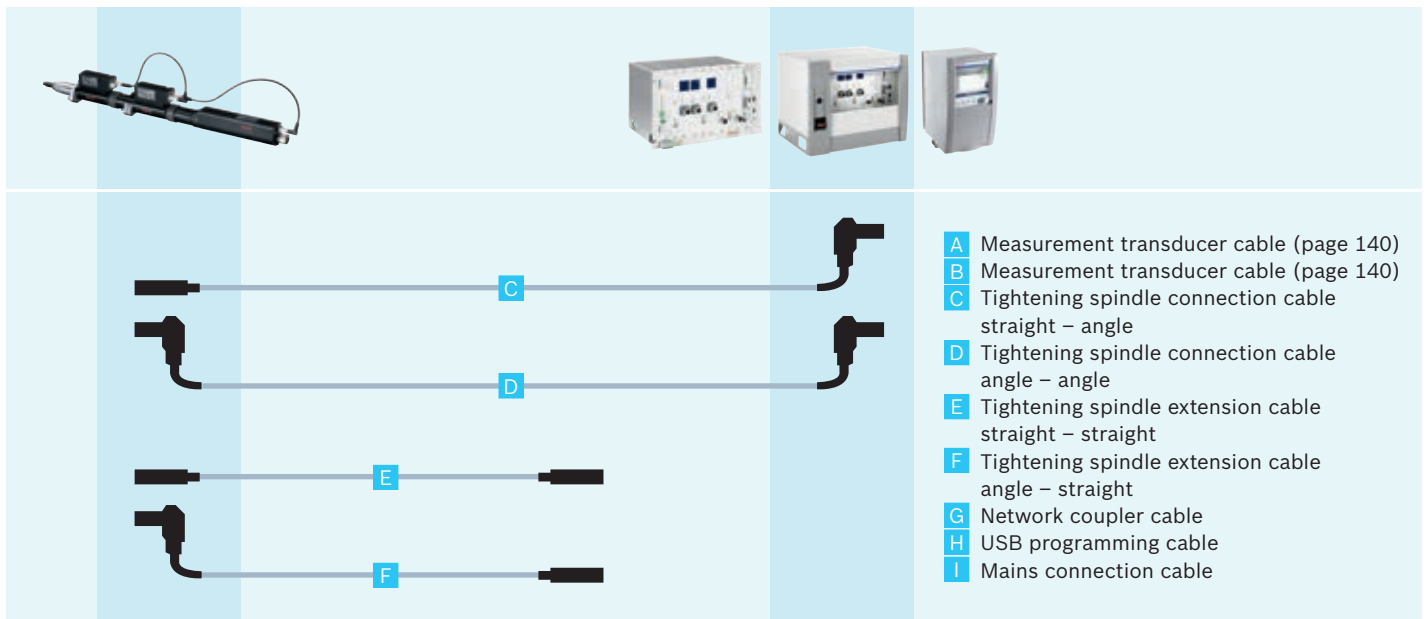

TIGHTENING SPINDLE CONNECTION CABLE

The tightening spindle is connected to the CS351S... Compact System or the LTS350D servo amplifier via a connection cable. Up to 5 extension cables may be connected to the connection cable one after the other in any order. For applications where the tightening spindle is in constant motion, we recommend constructing the connection from several individual parts.

Max. length of the connection cable:

- ▶ When connecting to a system box or card rack: 100 m
- ▶ When connecting to a Compact System: 50 m



CONNECTING CARD RACKS AND SYSTEM BOXES

The network coupler cables connect individual BT356 card racks and SB356 system boxes. A combination of card racks and system boxes is also possible. The length of the network coupler cable between the individual card racks / system boxes can be as much as 50 m. The total length of all network coupler cables may not exceed 150 m. Network coupler cables are not extendable.

NOTE

To ensure function and system reliability at all times, only use the cables listed here. The connection cables for tightening spindles are suitable for robot use.

| | Code | Order no. | Length m | Weight kg |
|----------|-----------------|--------------|-------------|--------------|
| C | S-003-S-A | 0608 740 100 | 3 | 1.015 |
| | S-005-S-A | 0608 740 101 | 5 | 1.495 |
| | S-007-S-A | 0608 740 102 | 7 | 1.975 |
| | S-010-S-A | 0608 740 103 | 10 | 2.695 |
| | S-015-S-A | 0608 740 104 | 15 | 3.895 |
| | S-020-S-A | 0608 740 105 | 20 | 5.095 |
| | S-FREE-S-A* | 0608 741 100 | >0.5 | - |
| D | S-003-A-A | 0608 740 110 | 3 | 1.060 |
| | S-005-A-A | 0608 740 111 | 5 | 1.540 |
| | S-007-A-A | 0608 740 112 | 7 | 2.020 |
| | S-010-A-A | 0608 740 113 | 10 | 2.740 |
| | S-015-A-A | 0608 740 114 | 15 | 3.940 |
| | S-FREE-A-A* | 0608 741 110 | >0.5 | - |
| E | S-EXT-003-S-S | 0608 740 120 | 3 | 0.970 |
| | S-EXT-005-S-S | 0608 740 121 | 5 | 1.450 |
| | S-EXT-007-S-S | 0608 740 122 | 7 | 1.930 |
| | S-EXT-010-S-S | 0608 740 123 | 10 | 2.650 |
| | S-EXT-015-S-S | 0608 740 124 | 15 | 3.850 |
| | S-EXT-020-S-S | 0608 740 125 | 20 | 5.050 |
| | S-EXT-FREE-S-S* | 0608 741 120 | >0.5 | - |
| F | S-EXT-003-A-S | 0608 740 130 | 3 | 1.015 |
| | S-EXT-005-A-S | 0608 740 131 | 5 | 1.495 |
| | S-EXT-007-A-S | 0608 740 132 | 7 | 1.975 |
| | S-EXT-010-A-S | 0608 740 133 | 10 | 2.695 |
| | S-EXT-FREE-A-S* | 0608 741 130 | >0.5 | - |

| | Code | Order no. | Length m | Weight kg |
|----------|-------------------|---------------------|-------------|--------------|
| G | NKL0.6 | 3 608 877 369 | 0.6 | - |
| | NKL002 | 3 608 877 370 | 2 | - |
| | NKL003 | 3 608 879 240 | 3 | - |
| | NKL005 | 3 608 877 371 | 5 | - |
| | NKL010 | 3 608 877 372 | 10 | - |
| | NKLF* | 3 608 877 373 / ... | >0.5 | - |
| H | USB350 | 3 608 877 427 | 3 | - |
| I | CS351USC (110V)** | 3 608 877 033 | 1.8 | - |

* The connection cables S-FREE-S-A **C**, S-FREE-A-A **D** as well as extension cables S-EXT-FREE-S-S **E**, S-EXT-FREE-A-S **F** and the network coupler cable NKLF **G** require a length specification in addition to the part number. The "FREE" in the code stands for flexible cable lengths in 0.25-m increments. The length and order number must both be indicated on your order.

Ordering example: Connection cable **C** 17.75 m long is S-FREE-S-A 0 608 741 100 /17.75

Calculation of the weight for free lengths:

Weight of cable: 240 g/m
Weight angle plug: 170 g
Weight straight plug: 125 g

** Mains connection cable USA (The mains connection cable is included in the standard scope of delivery for Europe.)

Measurement transducer cables



TIGHTENING SPINDLE WITH SPINDLE BEARING, OFFSET OUTPUT DRIVE, OR ANGLE HEAD

| Size | A | Code | Order no. |
|------|-----------------------|-------|---------------|
| 2 | | MC038 | 0 608 730 100 |
| 3 | | MC038 | 0 608 730 100 |
| 4 | | MC046 | 0 608 730 101 |
| 5 | | MC061 | 0 608 730 103 |
| 5 | With blocking adapter | MC072 | 0 608 730 104 |

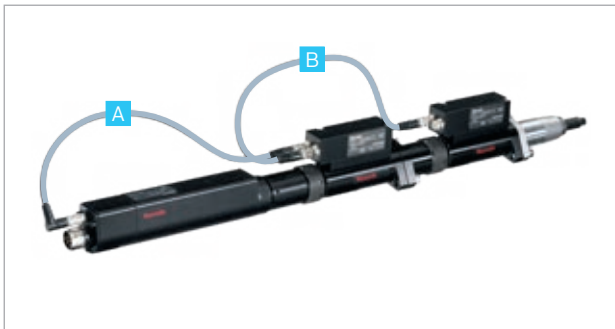

TIGHTENING SPINDLE WITH SPINDLE BEARING, OFFSET OUTPUT DRIVE OR ANGLE HEAD AND REDUNDANT MEASUREMENT TRANSDUCER

| Size | A | Code | Order no. | B | Code | Order no. |
|------|---|-------|---------------|---|--------|---------------|
| 2 | | MC038 | 0 608 730 100 | | MCR033 | 0 608 730 200 |
| 3 | | MC038 | 0 608 730 100 | | MCR033 | 0 608 730 200 |
| 4 | | MC046 | 0 608 730 101 | | MCR033 | 0 608 730 200 |
| 5 | | MC061 | 0 608 730 103 | | MCR040 | 0 608 730 201 |



TIGHTENING SPINDLE WITH OFFSET OUTPUT DRIVE WITH INTEGRATED MEASUREMENT TRANSDUCER

| Size | VMC | A | Code | Order no. |
|------|---------|---|-------|---------------|
| 3 | 3VMC0.. | | MC046 | 0 608 730 101 |
| 4 | 4VMC150 | | MC055 | 0 608 730 102 |
| 4 | 4VMC210 | | MC055 | 0 608 730 102 |
| 4 | 4VMC360 | | MC061 | 0 608 730 103 |

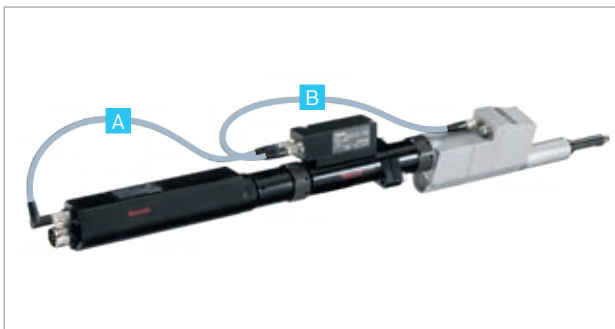

TIGHTENING SPINDLE WITH OFFSET OUTPUT DRIVE WITH INTEGRATED MEASUREMENT TRANSDUCER AND REDUNDANT MEASUREMENT TRANSDUCER

| Size | VMC | A | Code | Order no. | B | Code | Order no. |
|------|---------|---|-------|---------------|---|--------|---------------|
| 3 | 3VMC0.. | | MC038 | 0 608 730 100 | | MCR045 | 0 608 730 202 |
| 4 | 4VMC150 | | MC046 | 0 608 730 101 | | MCR040 | 0 608 730 201 |
| 4 | 4VMC210 | | MC046 | 0 608 730 101 | | MCR040 | 0 608 730 201 |
| 4 | 4VMC360 | | MC046 | 0 608 730 101 | | MCR045 | 0 608 730 202 |



TIGHTENING SPINDLE WITH TRANSVERSE GEARBOX

| Size | A | Code | Order no. |
|------|---|-------|---------------|
| 2 | | MC046 | 0 608 730 101 |
| 3 | | MC046 | 0 608 730 101 |
| 4 | | MC046 | 0 608 730 101 |
| 5 | | MC061 | 0 608 730 103 |

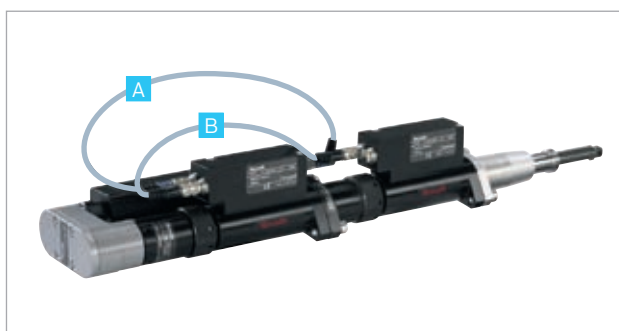

TIGHTENING SPINDLE WITH TRANSVERSE GEARBOX AND REDUNDANT MEASUREMENT TRANSDUCER

| Size | A | Code | Order no. | B | Code | Order no. |
|------|---|-------|---------------|---|--------|---------------|
| 2 | | MC046 | 0 608 730 101 | | MCR033 | 0 608 730 200 |
| 3 | | MC046 | 0 608 730 101 | | MCR033 | 0 608 730 200 |
| 4 | | MC046 | 0 608 730 101 | | MCR033 | 0 608 730 200 |
| 5 | | MC061 | 0 608 730 103 | | MCR040 | 0 608 730 201 |

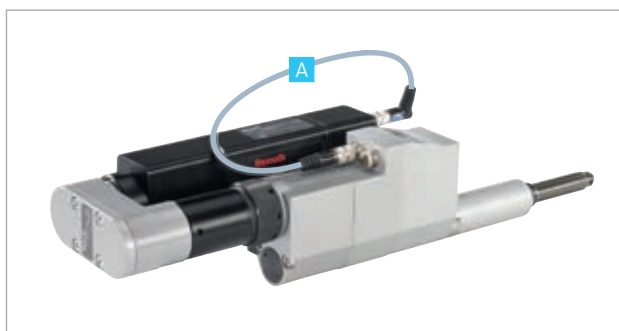

TIGHTENING SPINDLE WITH OFFSET OUTPUT DRIVE WITH INTEGRATED MEASUREMENT TRANSDUCER AND TRANSVERSE GEARBOX

| Size | VMC | A | Code | Order no. |
|------|---------|---|-------|---------------|
| 3 | 3VMC0.. | | MC038 | 0 608 730 100 |
| 4 | 4VMC150 | | MC038 | 0 608 730 100 |
| 4 | 4VMC210 | | MC038 | 0 608 730 100 |
| 4 | 4VMC360 | | MC038 | 0 608 730 100 |

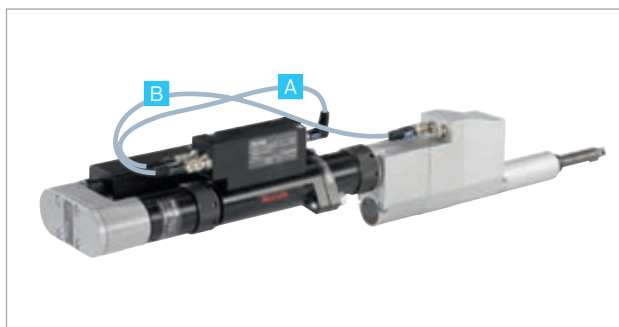

TIGHTENING SPINDLE WITH OFFSET OUTPUT DRIVE WITH INTEGRATED MEASUREMENT TRANSDUCER AND TRANSVERSE GEARBOX AND REDUNDANT MEASUREMENT TRANSDUCER

| Size | VMC | A | Code | Order no. | B | Code | Order no. |
|------|---------|---|-------|---------------|---|--------|---------------|
| 3 | 3VMC0.. | | MC038 | 0 608 730 100 | | MCR045 | 0 608 730 202 |
| 4 | 4VMC150 | | MC038 | 0 608 730 100 | | MCR040 | 0 608 730 201 |
| 4 | 4VMC210 | | MC038 | 0 608 730 100 | | MCR040 | 0 608 730 201 |
| 4 | 4VMC360 | | MC038 | 0 608 730 100 | | MCR045 | 0 608 730 202 |

Cables for ErgoSpin hand-held nutrunners with molded connectors

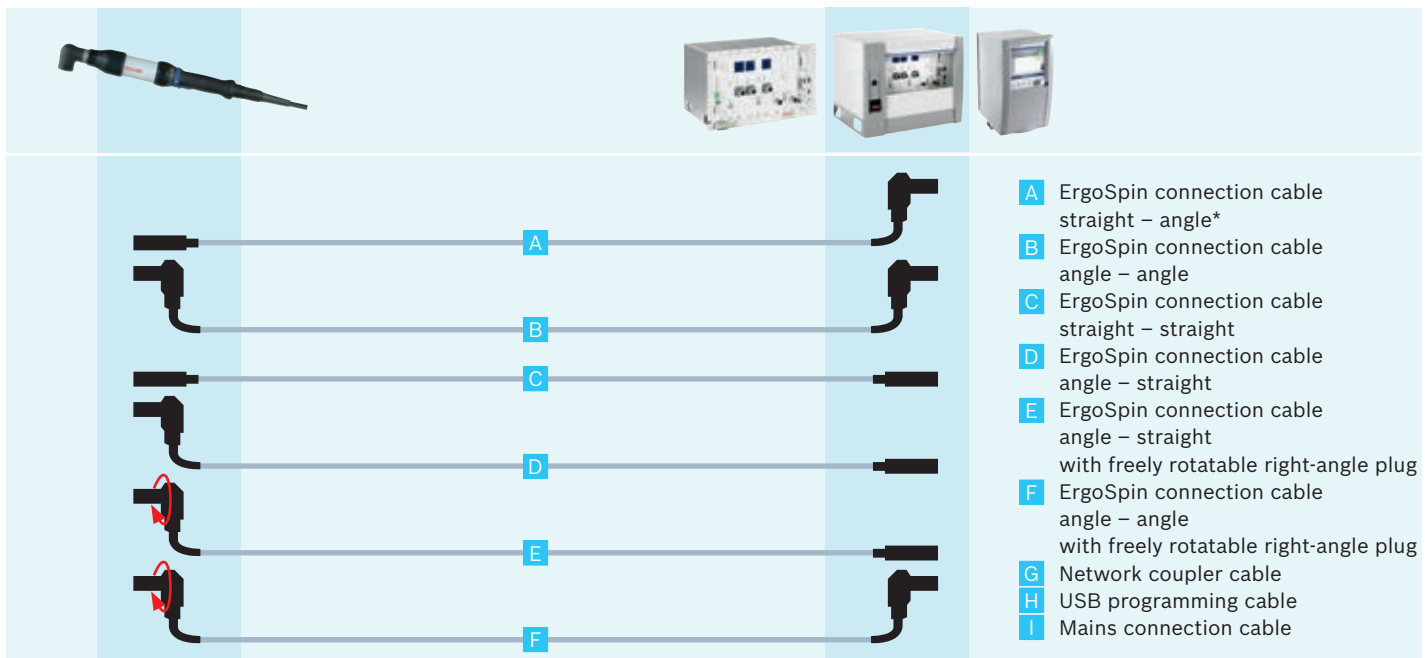
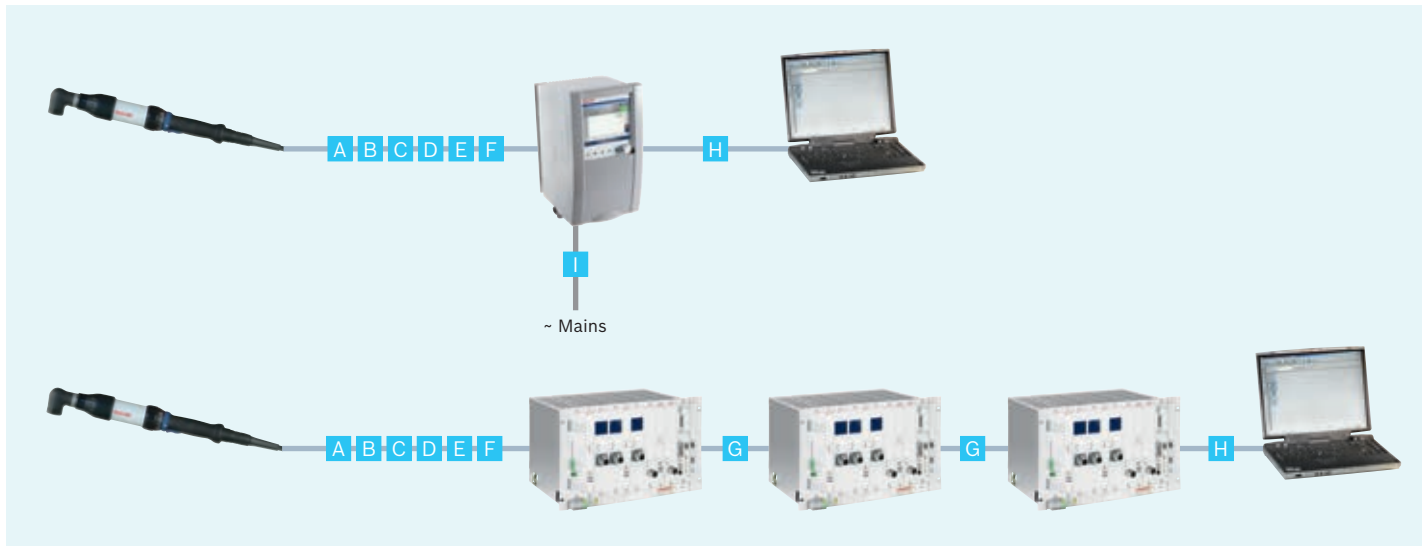

- A** ErgoSpin connection cable straight – angle*
- B** ErgoSpin connection cable angle – angle
- C** ErgoSpin connection cable straight – straight
- D** ErgoSpin connection cable angle – straight
- E** ErgoSpin connection cable angle – straight with freely rotatable right-angle plug
- F** ErgoSpin connection cable angle – angle with freely rotatable right-angle plug
- G** Network coupler cable
- H** USB programming cable
- I** Mains connection cable

* Connection cable S-A with extra-long bend relief on request

ERGOSPIN CONNECTION CABLE

The ErgoSpin hand-held nutrunner is connected to the CS351E... Compact System or the LTE350D servo amplifier via a connection cable. Up to 5 of the connection cables listed at the side may be connected one after the other in any order. For applications where the hand-held nutrunner is in constant motion, we recommend constructing the connection from several individual parts.

Max. length of the connection cable:

- ▶ When connecting to a system box or card rack: 100 m
- ▶ When connecting to a Compact System: 50 m



CONNECTING CARD RACKS AND SYSTEM BOXES

The network coupler cables connect individual BT356 card racks and SB356 system boxes. A combination of card racks and system boxes is also possible. The length of the network coupler cable between the individual card racks / system boxes can be as much as 50 m. The total length of all network coupler cables may not exceed 150 m. Network coupler cables are not extendable.

NOTE

To ensure function and system reliability at all times, only use the cables listed here. The ErgoSpin connection cables are suitable for robot use.

| | Code | Order no. | Length m | Weight kg |
|-------------|-----------------|--------------|-------------|--------------|
| A | E-003-S-A | 0608 740 200 | 3 | 1.015 |
| | E-005-S-A | 0608 740 201 | 5 | 1.495 |
| | E-007-S-A | 0608 740 202 | 7 | 1.975 |
| | E-010-S-A | 0608 740 203 | 10 | 2.695 |
| | E-015-S-A | 0608 740 204 | 15 | 3.895 |
| | E-020-S-A | 0608 740 205 | 20 | 5.095 |
| | E-FREE-S-A* | 0608 741 200 | >0.5 | - |
| B | E-003-A-A | 0608 740 210 | 3 | 1.06 |
| | E-005-A-A | 0608 740 211 | 5 | 1.54 |
| | E-007-A-A | 0608 740 212 | 7 | 2.02 |
| | E-010-A-A | 0608 740 213 | 10 | 2.74 |
| | E-FREE-A-A* | 0608 741 210 | >0.5 | - |
| C | E-003-S-S | 0608 740 220 | 3 | 0.97 |
| | E-005-S-S | 0608 740 221 | 5 | 1.45 |
| | E-007-S-S | 0608 740 222 | 7 | 1.93 |
| | E-010-S-S | 0608 740 223 | 10 | 2.65 |
| | E-FREE-S-S* | 0608 741 220 | >0.5 | - |
| D | E-003-A-S | 0608 740 230 | 3 | 1.015 |
| | E-005-A-S | 0608 740 231 | 5 | 1.495 |
| | E-007-A-S | 0608 740 232 | 7 | 1.975 |
| | E-010-A-S | 0608 740 233 | 10 | 2.695 |
| E-FREE-A-S* | 0608 741 230 | >0.5 | - | |
| E | E-003-ROT-A-S | 0608 740 240 | 3 | 1.07 |
| | E-005-ROT-A-S | 0608 740 241 | 5 | 1.55 |
| | E-007-ROT-A-S | 0608 740 242 | 7 | 2.03 |
| | E-010-ROT-A-S | 0608 740 243 | 10 | 2.75 |
| | E-FREE-ROT-A-S* | 0608 741 240 | >0.5 | - |

| | Code | Order no. | Length m | Weight kg |
|-------|--------------------|--------------|-------------|--------------|
| F | E-003-ROT-A-A | 0608 740 250 | 3 | 1.115 |
| | E-005-ROT-A-A | 0608 740 251 | 5 | 1.595 |
| | E-007-ROT-A-A | 0608 740 252 | 7 | 2.075 |
| | E-010-ROT-A-A | 0608 740 253 | 10 | 2.795 |
| | E-FREE-ROT-A-A* | 0608 741 250 | >0.5 | - |
| G | NKL0.6 | 3608 877 369 | 0.6 | - |
| | NKL002 | 3608 877 370 | 2 | - |
| | NKL003 | 3608 879 240 | 3 | - |
| | NKL005 | 3608 877 371 | 5 | - |
| | NKL010 | 3608 877 372 | 10 | - |
| NKLF* | 3608 877 373 / ... | >0.5 | - | |
| H | USB350 | 3608 877 427 | 3 | - |
| I | CS351USC (110V)** | 3608 877 033 | 1.8 | - |

* The connection cables E-FREE-S-A [A], E-FREE-A-A [B], E-FREE-S-S [C], E-FREE-A-S [D], E-FREE-ROT-A-S [E], E-FREE-ROT-A-A [F] and NKLF [G] require a length specification in addition to the part number. The "FREE" in the code stands for flexible cable lengths in 0.25-m increments. The length and order number must both be indicated on your order.

Ordering example: Connection cable [A] 17.75 m long is
E-FREE-S-A 0 608 741 200 / 17.75

Calculation of the weight for free lengths:

Weight of cable: 240 g/m
Weight angle plug: 170 g
Weight freely rotatable angle plug: 225 g
Weight straight plug: 125 g

** Mains connection cable USA (The mains connection cable is included in the standard scope of delivery for Europe.)

The complete package: software and operating system

Easy configuration, parameterization and analysis: with the PC via the network or with the laptop on-site. This provides a flexible working environment and allows you to generate tightening programs as well as analyze tightening cases and conduct system tests. The user interface enables intuitive operation.



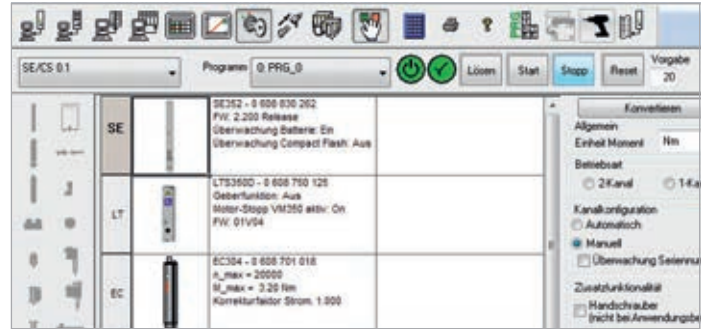

- ▶ Fast commissioning thanks to intuitive menu design
- ▶ Time-saving and mix-up-proof thanks to automatic detection of electronic components
- ▶ Simple entry of tightening process parameters
- ▶ Comprehensive selection of target and monitoring functions for adaptation to the individual tightening case
- ▶ Evaluation options using graphs and statistics for process optimization

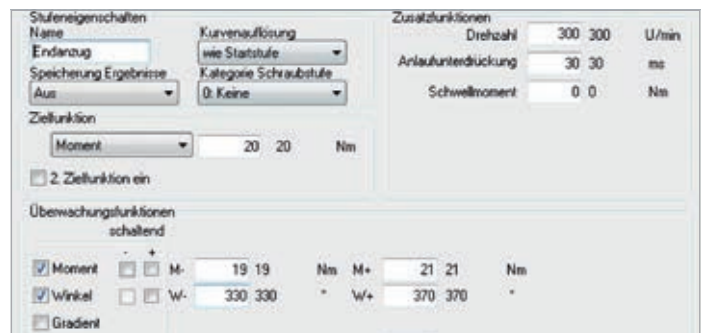

CONFIGURATION AND PROGRAMMING

- ▶ Programming via convenient, icon-supported tools
- ▶ Configuration of tightening processes on the graphic interface
- ▶ Target and monitoring parameters are easily entered in the preset windows

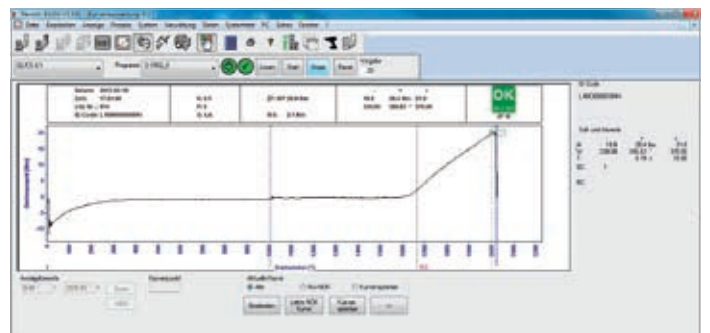

ANALYSIS

- ▶ Tightening graph for performing a quick tightening case analysis
- ▶ Good range with clear display of the state of the tightening results in the target window
- ▶ Histogram provides a quick overview of the statistical distribution of the tightening results

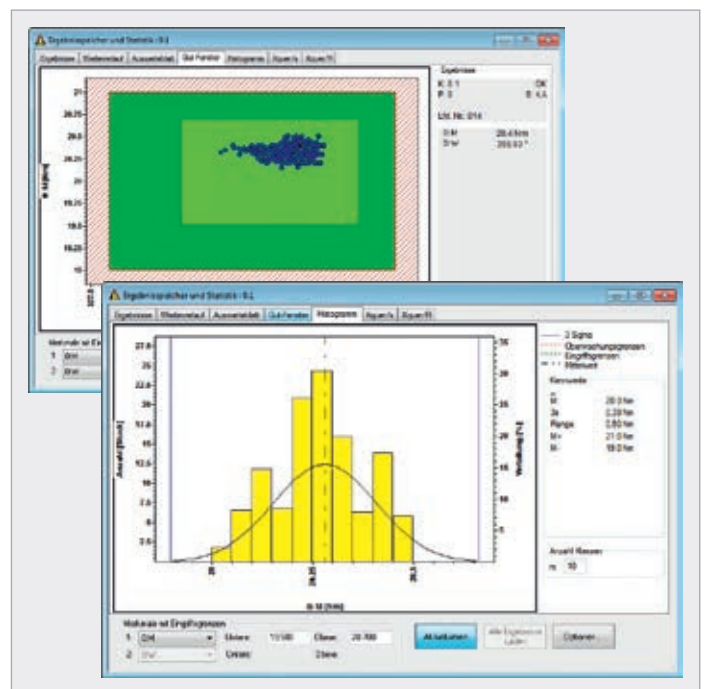

BS350 operating system

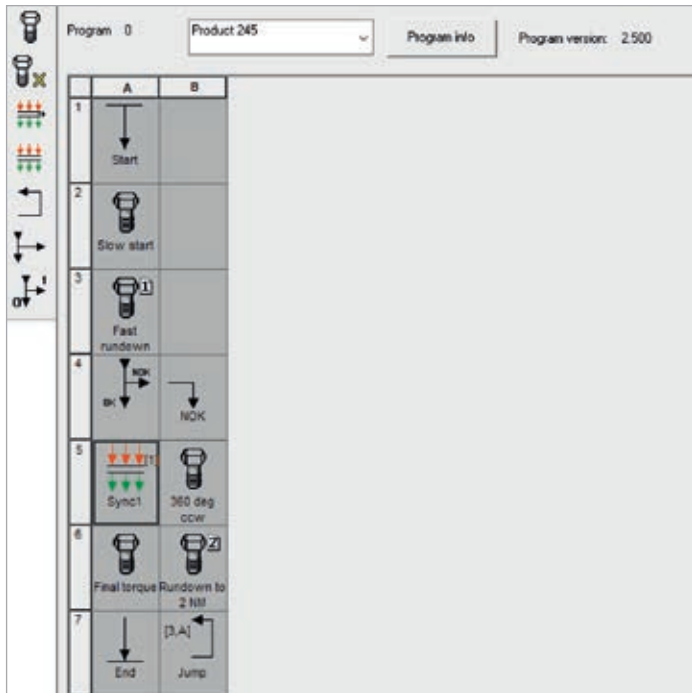

- Software for actuation, programming and monitoring of tightening processes



INTUITIVE, RELIABLE TIGHTENING PROCESSES

System installation and programming of individual tightening tasks is done via convenient, icon-supported tools. Tightening processes are configured on the graphic interface.

SYSTEM REQUIREMENTS

- BS350 V2.600: Windows 7 and Windows 10
- Connection to tightening system: via USB or Ethernet.

NOTE

Rexroth is constantly adapting its products to meet the latest technological standards and thus retains the right to change its software and firmware. Find out about the latest software as well as software and firmware updates on the Internet at www.boschrexroth.com/tightening.



You can easily enter target and monitoring parameters in the preset windows.

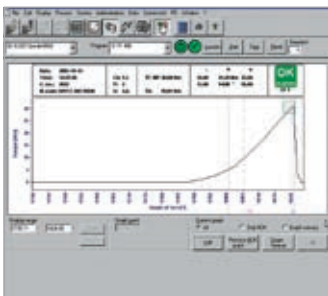

Graph

The tightening graph helps you quickly analyze tightening cases.

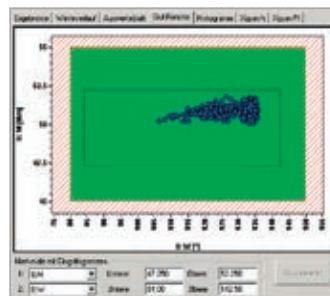

Good range window

The good range window clearly shows you the location of tightening results in the target window.

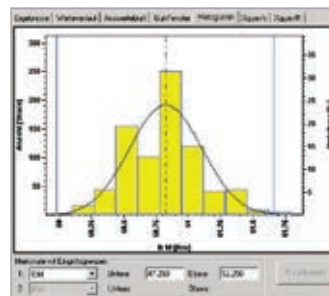

Histogram

The histogram gives you a quick overview of the statistical distribution of the tightening results.

The results window displays a table with multiple columns, including 'Result', 'Date', 'Program', and 'Time'. The table contains numerous rows of data, with some rows highlighted in green and others in red, likely representing different status or quality levels.

Results window

Internal results memory of up to 40,000 tightening results and filter search functionality.

| Code | License | Order no. | Language versions* |
|----------------|---------------|---------------|--------------------|
| BS350 V2.600 1 | 1 x license | 0 608 830 315 | de/fr/it/en/es/pt/ |
| BS350 V2.600 2 | 10 x license | 0 608 830 316 | cs/hu/sk/pl/ru/zh |
| BS350 V2.600 3 | Plant license | 0 608 830 317 | |

* Language versions

de = German
fr = French
it = Italian

en = (US-)English
es = Spanish
pt = Portuguese

cs = Czech
hu = Hungarian
sk = Slovakian

pl = Polish
ru = Russian
zh = Simplified Chinese

IndraWorks – the tool for all engineering tasks

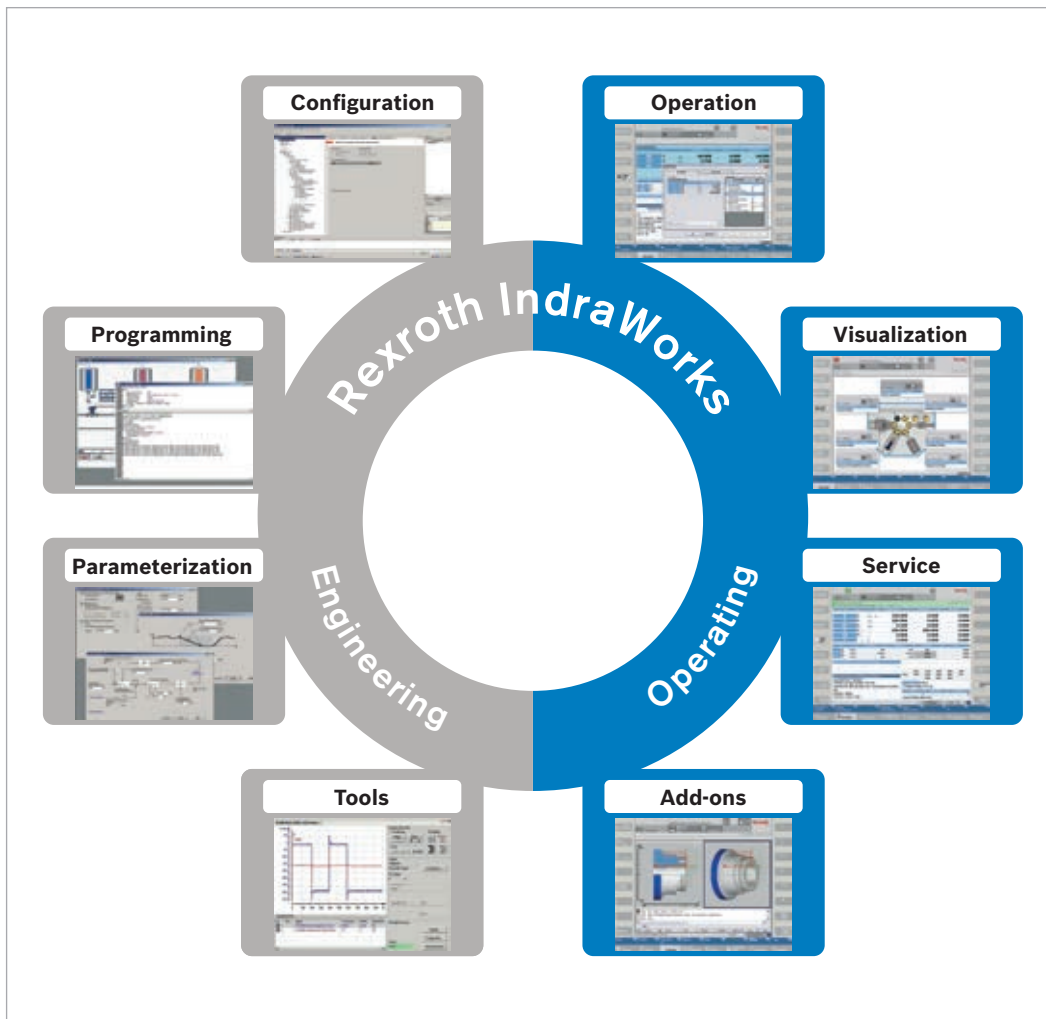

- ▶ Engineering framework for all Rexroth automation systems
- ▶ The tool for all engineering tasks

FEATURES

- ▶ Available for all systems and solutions from Rexroth
- ▶ Integrated framework for all engineering tasks
- ▶ Consistent operating environment for project planning, programming, visualization, and diagnostics
- ▶ Central project management with intuitive system navigation
- ▶ Intelligent operation with wizard support
- ▶ Comprehensive online help
- ▶ Uniform programming according to the PLC standard IEC 61131-3
- ▶ PLCopen-conform function block and technology libraries
- ▶ Standardized interfaces for communication
- ▶ Transparent access to all system components
- ▶ Integrated FDT/DTM interface for integration of the DTM of third-party manufacturers

Rexroth IndraWorks allows you to solve all tasks in a uniform and intuitive software environment – from project planning and programming to visualization and diagnostics.

The standardized tools and interfaces help you to solve all engineering tasks centrally with a single software.

The uniform engineering framework IndraWorks is consistently available for all systems from Rexroth. You, as user, profit from fast and transparent access to all functions and system data of the automation components.

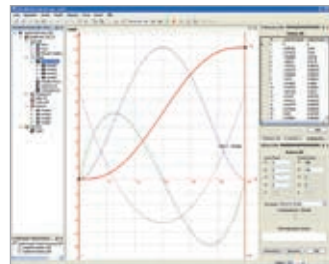
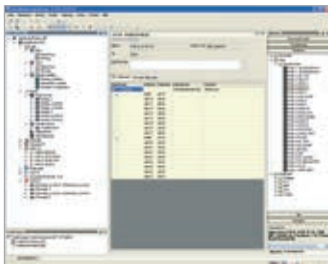

Project development

The overall system is uniformly and consistently projected for all solutions. User and multi-project management are available in all instances. The project and device explorers provide access to all system components. With its clearly organized dialog boxes, IndraWorks guides you intuitively through the configuration of your system.

Programming

The IndraLogic runtime system that is integrated in all solutions is consistently programmed in IndraWorks. The complete language scope specified in IEC 61131-3 is available. System-specific additional functions, such as motion blocks according to PLCopen or technology blocks, can be quickly and transparently implemented in your logic programs.

Tools

The tools for all engineering tasks are integrated in IndraWorks. Additional solution-specific tools are consistently available in the software framework.

You can find information on IndraWorks for the 350 Tightening System in the Internet at www.boschrexroth.com/tightening

| Description | Type key | Order no. |
|--------------------------------------|-------------------------------|---------------|
| IndraWorks for 350 Tightening System | SWA-IWORKS-ML*-12VRS-D0-DVD** | R 911 334 632 |

Operator Guidance System

For complex manual tightening tasks in the automotive industry, special attention needs to be paid to process reliability. The Operator Guidance System allows you to support your employees as best as possible in the assembly of products with many variants.



The virtual guidance system supports the employee through the individual work steps with step-by-step instructions on a screen. It ensures that the correct components and tools are used for each process and the parts are assembled correctly. Production errors are avoided in this way and the quality is improved significantly. Manufacturers can increase the process reliability and productivity of their productions using the Operator Guidance System.

The Operator Guidance System runs on standard computers and can be integrated easily in higher-level ERP systems. In addition to hand-held nutrunners, you can also flexibly integrate other peripheral devices, such as torque wrenches, scanners, socket trays or pick-to-light systems. The assistance system supports automotive-specific protocols and data output in conventional formats. The system detects errors immediately and gives direct instructions on how to correct them. It visualizes every process step, including all manual processes. This allows you to achieve maximum process reliability and transparency in your assembly.



SUPPORTED FUNCTIONS

- ▶ One active tool per station at a time
- ▶ Component hierarchy: component, operation, job
- ▶ Pre-tightening, final tightening, manual clicking
- ▶ Preset or freely selectable tightening sequence
- ▶ Selection of component, operation and job by means of bar code or PLC
- ▶ Tool selection by means of socket trays
- ▶ Pick-to-light via Modbus-TCP/UDP
- ▶ Interruption and resumption of processing sequences
- ▶ Flexible interfaces for ID codes and result data output

HARDWARE REQUIREMENTS

- ▶ Standard PC (i3 CPU, 4 GB RAM, 128 GB SSD, full HD (1080P) Monitor, Windows 10)
- ▶ Touch operation possible

SCOPE OF FUNCTIONS –

INTERFACES AND EXPANSION OPTIONS

- ▶ 4.0 interfaces (SignalR and MQTT)
- ▶ Driver interface for tightening systems
- ▶ CS/KE (PROFIBUS) and open protocol (Nexo cordless nutrunner)
- ▶ Torque wrench (e.g. SCS)
- ▶ Socket tray (USB/Lan/Wifi/PROFIBUS/PROFINET)
- ▶ Worker identification
- ▶ Position visualization and determination of the order of the tightening positions
- ▶ Modbus-TCP, e.g. pick-to-light
- ▶ Lua-Scripting for flexible adaptations
- ▶ Data output interfaces
- ▶ XML file (“Motis”), text file (“Csv”)
- ▶ Export/archiving from local database

Rexroth Service – the Original!

Your experts for controlled tightening technology



Get in contact with us per
phone or per e-mail:
+49 9352 405060
repair.jt@boschrexroth.de

As a full provider of electrical tightening systems, Bosch Rexroth not only offers an extensive product portfolio and individual customer solutions, but also a varied range of worldwide services.

Rexroth's tightening technology service supports you with tailor-made services in accordance with individual specifications and specific quality standards. It does so in a fast, professional, and reliable manner. Rexroth supports end users and machine manufacturers over the entire life cycle of their machines and systems. In order to ensure the long-term availability and efficiency of tightening systems used in the field, the Rexroth repair service repairs and maintains them in an OEM quality level. Optionally they can happen as a standard, urgent, or rush job.

You need support with optimizing your tightening processes? You have questions about retrofit and upgrade options? No problem. Our experienced service experts look forward to offering you a consultation.

The qualification of your employees is a key and an indispensable element to gain crucial advantages in the global competition. As one of the world's leading specialists, Rexroth has a deep technological know-how. The Rexroth Service conveys this expertise as part of basic and hands-on product training sessions. In addition, training courses tailored to your individual needs and requirements ensure effective and sustainable learning and further knowledge for your employees. This can happen at Rexroth training sites or directly in your factory.

WORLDWIDE SERVICE

Our global service network can be reached at any time in over 40 countries. You can find detailed information on service locations on the Internet at:

www.boschrexroth.com/service.

SERVICE PORTFOLIO

- ▶ Consulting
- ▶ Training
- ▶ Fieldservice
- ▶ Spare parts management
- ▶ Repair service
- ▶ Product overhaul
- ▶ Maintenance
- ▶ Machine capability analysis
- ▶ Measuring transducer test
- ▶ Re-use
- ▶ Modernization

Additional information on Rexroth's tightening technology service can be found at **www.boschrexroth.com/tightening**



Customized, future-proof production with Rexroth Assembly Technology

Working environments are all the more efficient when they are individually tailored to meet the respective production requirements. From flow racks and frames made of aluminum profiles, enclosures, ergonomic assembly work stations through to fully automated manufacturing lines with transfer systems: Based on decades of practical experience, the sophisticated and uniquely versatile assembly technology from Bosch Rexroth is continuously being further developed. With modular, finely coordinated components, Bosch Rexroth facilitates the realization of customized, future-proof solutions for your production.



Further information on Assembly Technology products can be found in the corresponding catalogs at the Rexroth Media Directory:
www.boschrexroth.com/mediadirectory

Assembly Technology

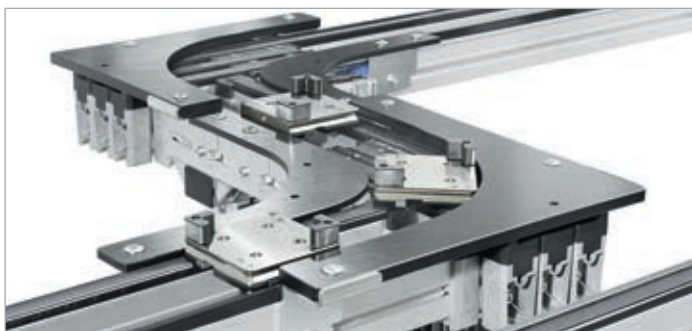

TRANSFER SYSTEM TS 1

Weight class: 0–3 kg

Workpiece pallet sizes: 80 x 80 up to 160 x 160 mm

The TS 1 transfer system is specifically tailored to small, lightweight products and assemblies, which require high positioning accuracy and repeatability.

| | |
|---------|------------|
| Catalog | 3842528596 |
|---------|------------|

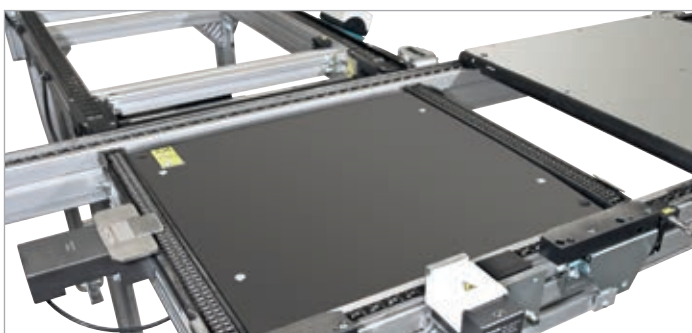

TRANSFER SYSTEM TS 2plus

Weight class: 0–240 kg

Workpiece pallet sizes: 160 x 160 up to 1,200 x 1,200 mm

From the automotive industry and the electronics industry to household appliances and electronics manufacturing: With their diverse system components, TS 2plus assembly lines are suitable for use in a wide range of industries.

| | |
|---------|------------|
| Catalog | R999000395 |
|---------|------------|

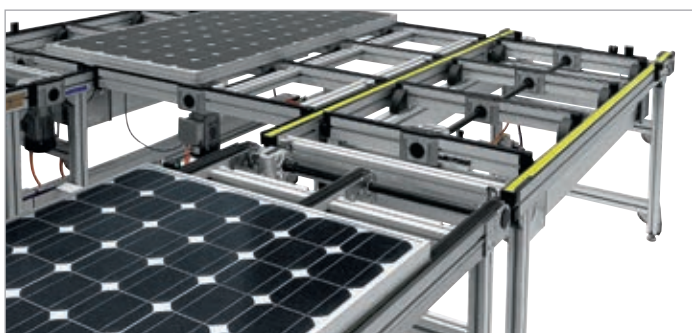

TRANSFER SYSTEM TS 2pv

Panel weight: 0–120 kg

Panel sizes: 0–2,200 mm edge length

The transport system TS 2pv was developed as a tailor-made solution for the solar industry. Photovoltaic modules in both thin-film and silicon cell technology can be transported directly.

| | |
|---------|------------|
| Catalog | 3842540431 |
|---------|------------|



TRANSFER SYSTEM TS 5

Weight class: 0–< 400 kg

Workpiece pallet sizes: 455 x 455 up to 1,040 x 845 mm

The roller conveyor TS 5 conveys loads of up to 400 kg or more even over long distances and its robust construction make it especially suitable for harsh and oily environments.

| | |
|---------|------------|
| Catalog | 3842540379 |
|---------|------------|

Assembly Technology

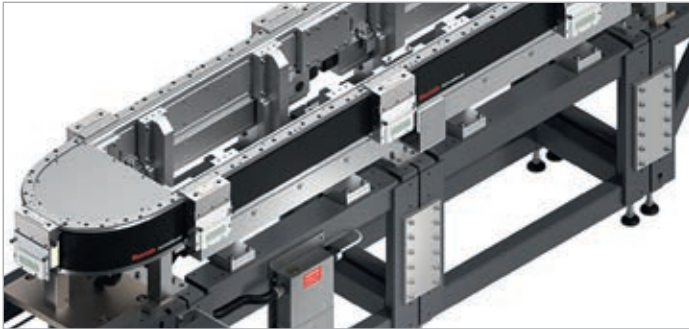

LINEAR MOTOR-DRIVEN TRANSFER SYSTEM

ActiveMover

Weight class: 0–10 kg (depending on number of magnets)
If products have to be transported particularly quickly and precisely. The workpiece pallets accelerate with up to 4 g and achieve an extremely high dynamic. ActiveMover covers is used e.g. in electronics production, the automotive supply industry, medical technology and life sciences.

Catalog

R999001426



RFID SYSTEMS

RFID systems ensure the flow of information accompanying goods in the assembly lines. Object-related data enable the targeted control of process and processing steps, as well as the type- or variant-dependent inward and outward transfer of workpiece pallets during the production of product variants on branched, flexible assembly systems. By documenting all process steps and production data, traceability when errors occur is also possible.

All RFID systems from Rexroth are read/write systems and support common fieldbuses. They are perfectly matched to the transfer systems and the VarioFlow chain conveyor system.

Catalog

3 842 541 003



CHAIN CONVEYOR SYSTEM VarioFlow plus

Chain tension: up to 1,250 N (ESD 600 N)

Track width: 65/90/120/160/240/320 mm

With VarioFlow *plus*, Rexroth offers you a versatile, high-performance and standardized conveyor system for use in the fields of food and packaging, health care, automotive and electronics assembly lines and machine interlinking.

Catalog

R999000401



BASIC MECHANIC ELEMENTS

Bosch Rexroth offers you decades of experience and unbeatable flexibility when designing your assembly line – with the world’s largest aluminum profile building system. The robust and corrosion-resistant Rexroth profiles allow you to realize components such as ergonomic work tables, flow racks, or protective fences within a short time and without having to spend great effort on planning.

Catalog **3842540391**



MANUAL PRODUCTION SYSTEMS

Based on the three pillars of the Manual Production Systems covering workstations, material supply and linking, you can create, for example workstations, as well as entire production lines, that can be quickly adapted to your work content and executed in an extremely efficient manner and avoiding waste in line with „lean“ principles.

Catalog **3842538280**

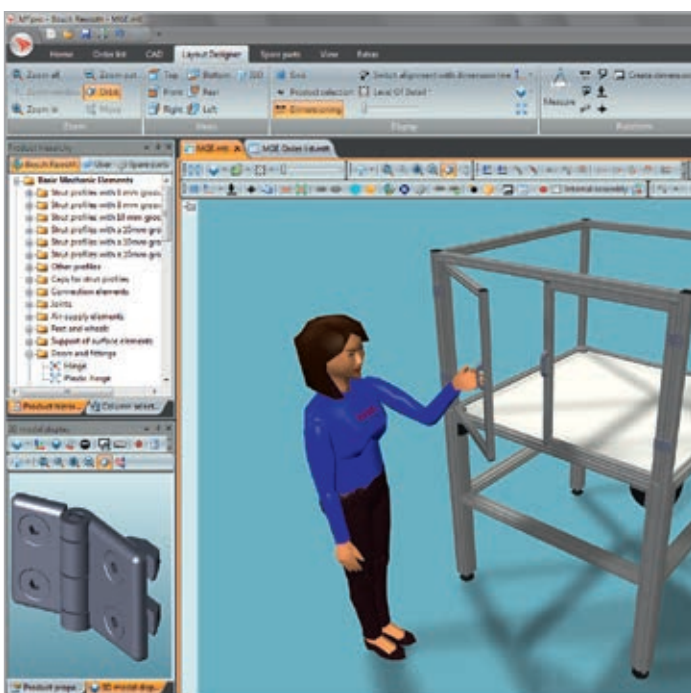

MTpro - PLANNING SOFTWARE

This especially user-friendly software speeds up and simplifies the planning of application-specific frames, enclosures and workstations. Unlimited combination options together with simple planning and ordering as well as excellent adherence to deadlines allow you to achieve perfect results. The entire ordering process can also be done in next to no time. The data can be transferred to your CAD or VR (Virtual Reality) environment via a CAD interface.

The program offers the following functions and full content in seven languages (en/de/fr/es/it/ja/zh):

- ▶ Complete product information
- ▶ CAD library
- ▶ Quick & Easy configurator
- ▶ Profile deflection calculation
- ▶ Conversion of profile drawings
- ▶ Quick and simple planning in the layout designer

Catalog **3 842 539 057**

Rating of a tightening connection

The basic value for the rating of a tightening connection is the clamp force required to ensure the functioning of the tightening connection. Clamp force F_k must always be greater than the acting force F_A to be expected in operation ($F_k > F_A$).

The maximum number of bolts and their maximum thread value result from the design conditions, i.e. the space available for the bolts. A maximum permissible force of F_{max} can be calculated taking into consideration the stress cross-section of the bolt and the number of bolts. With currently available technology it is not possible to directly measure the clamp force (pretensioned force) during the tightening process. Therefore, it is necessary to rely on torque and angle of turn instead.

Especially in the case of torque-controlled tightening processes the clamp force is strongly influenced by the friction under the bolt head and in the threads. A tightening connection should be designed so that the minimal attainable pretensioned force F_{Mmin} guarantees the functioning of the tightening connection, but the maximum pretensioned force F_{Mmax} does not destroy the tightening connection or bolt. In order to be able to make a statement as to how the cited values will affect the mounting clamp force, the tightening factor $\alpha A = \frac{F_{Mmax}}{F_{Mmin}}$ was established in VDI 2230.

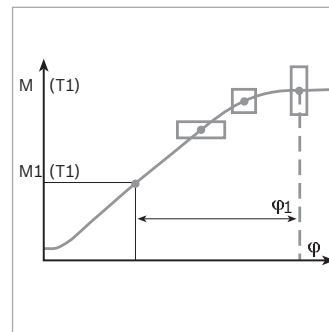
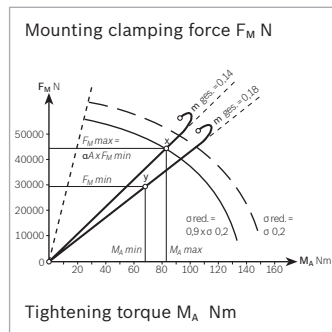
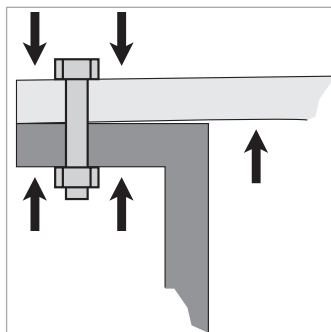

Example:
M10 DIN 912-12 μ total = 0.14 – 0.18

Clamping force table according to VDI 2230

| Abm. | Prop. class | Mounting clamp forces $F_{M Tab}$ in kN for $\mu_G =$ | | | | | | | Tightening torques M_A in Nm for $\mu_K = \mu_G =$ | | | | | | |
|------|-------------|---|-------|-------|-------|-------|-------|-------|--|-------|-------|-------|-------|-------|-------|
| | | 0.08 | 0.10 | 0.12 | 0.14 | 0.16 | 0.20 | 0.24 | 0.08 | 0.10 | 0.12 | 0.14 | 0.16 | 0.20 | 0.24 |
| M4 | 8.8 | 4.6 | 4.5 | 4.4 | 4.3 | 4.2 | 3.9 | 3.7 | 2.3 | 2.6 | 3.0 | 3.3 | 3.6 | 4.1 | 4.5 |
| | 10.9 | 6.8 | 6.7 | 6.5 | 6.3 | 6.1 | 5.7 | 5.4 | 3.3 | 3.9 | 4.6 | 4.8 | 5.3 | 6.0 | 6.6 |
| | 12.9 | 8.0 | 7.8 | 7.6 | 7.4 | 7.1 | 6.7 | 6.3 | 3.9 | 4.5 | 5.1 | 5.6 | 6.2 | 7.0 | 7.8 |
| M5 | 8.8 | 7.6 | 7.4 | 7.2 | 7.0 | 6.8 | 6.4 | 6.0 | 4.4 | 5.2 | 5.9 | 6.5 | 7.1 | 8.1 | 9.0 |
| | 10.9 | 11.1 | 10.8 | 10.6 | 10.3 | 10.0 | 9.4 | 8.8 | 6.5 | 7.6 | 8.6 | 9.5 | 10.4 | 11.9 | 13.2 |
| | 12.9 | 13.0 | 12.7 | 12.4 | 12.0 | 11.7 | 11.0 | 10.3 | 7.6 | 8.9 | 10.0 | 11.2 | 12.2 | 14.0 | 15.5 |
| M6 | 8.8 | 10.7 | 10.4 | 10.2 | 9.9 | 9.6 | 9.0 | 8.4 | 7.7 | 9.0 | 10.1 | 11.3 | 12.3 | 14.1 | 15.6 |
| | 10.9 | 15.7 | 15.3 | 14.9 | 14.5 | 14.1 | 13.2 | 12.4 | 11.3 | 13.2 | 14.9 | 16.5 | 18.0 | 20.7 | 22.9 |
| | 12.9 | 18.4 | 17.9 | 17.5 | 17.0 | 16.5 | 15.5 | 14.5 | 13.2 | 15.4 | 17.4 | 19.3 | 21.1 | 24.2 | 26.8 |
| M7 | 8.8 | 15.5 | 15.1 | 14.8 | 14.4 | 14.0 | 13.1 | 12.3 | 12.6 | 14.8 | 16.8 | 18.7 | 20.5 | 23.6 | 26.2 |
| | 10.9 | 22.7 | 22.5 | 21.7 | 21.1 | 20.5 | 19.3 | 18.1 | 18.5 | 21.7 | 24.7 | 27.5 | 30.1 | 34.7 | 38.5 |
| | 12.9 | 26.6 | 26.0 | 25.4 | 24.7 | 24.0 | 22.6 | 21.2 | 21.6 | 25.4 | 28.9 | 32.2 | 35.2 | 40.6 | 45.1 |
| M8 | 8.8 | 19.5 | 19.1 | 18.6 | 18.1 | 17.6 | 16.5 | 15.5 | 18.5 | 21.6 | 24.6 | 27.3 | 29.8 | 34.3 | 38.0 |
| | 10.9 | 28.7 | 28.0 | 27.3 | 26.6 | 25.8 | 24.3 | 22.7 | 27.2 | 31.8 | 36.1 | 40.1 | 43.8 | 50.3 | 55.8 |
| | 12.9 | 33.6 | 32.8 | 32.0 | 31.1 | 30.2 | 28.4 | 26.6 | 31.8 | 37.2 | 42.2 | 46.9 | 51.2 | 58.9 | 65.3 |
| M10 | 8.8 | 31.0 | 30.3 | 29.6 | 28.8 | 27.9 | 26.3 | 24.7 | 36 | 43 | 48 | 54 | 59 | 68 | 75 |
| | 10.9 | 45.6 | 44.5 | 43.4 | 42.2 | 41.0 | 38.6 | 36.2 | 53 | 63 | 71 | 79 | 87 | 100 | 110 |
| | 12.9 | 53.3 | 52.1 | 50.8 | 49.4 | 48.0 | 45.2 | 42.4 | 62 | 73 | 83 | 93 | 101 | 116 | 129 |
| M12 | 8.8 | 45.2 | 44.1 | 43.0 | 41.9 | 40.7 | 38.3 | 35.9 | 63 | 73 | 84 | 93 | 102 | 117 | 130 |
| | 10.9 | 66.3 | 64.8 | 63.2 | 61.5 | 59.8 | 56.3 | 52.8 | 92 | 108 | 123 | 137 | 149 | 172 | 191 |
| | 12.9 | 77.6 | 75.9 | 74.0 | 72.0 | 70.0 | 65.8 | 61.8 | 108 | 126 | 144 | 160 | 175 | 201 | 223 |
| M14 | 8.8 | 62.0 | 60.6 | 59.1 | 57.5 | 55.9 | 52.6 | 49.3 | 100 | 117 | 133 | 148 | 162 | 187 | 207 |
| | 10.9 | 91.0 | 88.9 | 86.7 | 84.4 | 82.1 | 77.2 | 72.5 | 146 | 172 | 195 | 218 | 238 | 274 | 304 |
| | 12.9 | 106.5 | 104.1 | 101.5 | 98.8 | 96.0 | 90.4 | 84.8 | 171 | 201 | 229 | 255 | 279 | 321 | 356 |
| M16 | 8.8 | 84.7 | 82.9 | 80.9 | 78.8 | 76.6 | 72.2 | 67.8 | 153 | 180 | 206 | 230 | 252 | 291 | 325 |
| | 10.9 | 124.4 | 121.7 | 118.8 | 115.7 | 112.6 | 106.1 | 99.6 | 224 | 264 | 302 | 338 | 370 | 428 | 477 |
| | 12.9 | 145.5 | 142.4 | 139.0 | 135.4 | 131.7 | 124.1 | 116.6 | 262 | 309 | 354 | 395 | 433 | 501 | 558 |
| M18 | 8.8 | 107 | 104 | 102 | 99 | 96 | 91 | 85 | 220 | 259 | 295 | 329 | 360 | 415 | 462 |
| | 10.9 | 152 | 149 | 145 | 141 | 137 | 129 | 121 | 314 | 369 | 421 | 469 | 513 | 592 | 657 |
| | 12.9 | 178 | 174 | 170 | 165 | 160 | 151 | 142 | 367 | 432 | 492 | 549 | 601 | 692 | 769 |
| M20 | 8.8 | 136 | 134 | 130 | 127 | 123 | 116 | 109 | 308 | 363 | 415 | 464 | 509 | 588 | 655 |
| | 10.9 | 194 | 190 | 186 | 181 | 176 | 166 | 156 | 438 | 517 | 592 | 661 | 725 | 838 | 933 |
| | 12.9 | 227 | 223 | 217 | 212 | 206 | 194 | 182 | 513 | 605 | 692 | 773 | 848 | 980 | 1092 |
| M22 | 8.8 | 170 | 166 | 162 | 158 | 154 | 145 | 137 | 417 | 495 | 567 | 634 | 697 | 808 | 901 |
| | 10.9 | 242 | 237 | 231 | 225 | 219 | 207 | 194 | 595 | 704 | 807 | 904 | 993 | 1,151 | 1,284 |
| | 12.9 | 283 | 277 | 271 | 264 | 257 | 242 | 228 | 696 | 824 | 945 | 1057 | 1162 | 1,347 | 1,502 |
| M24 | 8.8 | 196 | 192 | 188 | 183 | 178 | 168 | 157 | 529 | 625 | 714 | 798 | 875 | 1,011 | 1,126 |
| | 10.9 | 280 | 274 | 267 | 260 | 253 | 239 | 224 | 754 | 890 | 1,017 | 1,136 | 1,246 | 1,440 | 1,604 |
| | 12.9 | 327 | 320 | 313 | 305 | 296 | 279 | 262 | 882 | 1,041 | 1,190 | 1,329 | 1,458 | 1,685 | 1,877 |
| M27 | 8.8 | 257 | 252 | 246 | 240 | 234 | 220 | 207 | 772 | 915 | 1,050 | 1,176 | 1,292 | 1,498 | 1,672 |
| | 10.9 | 367 | 359 | 351 | 342 | 333 | 314 | 295 | 1,100 | 1,304 | 1,496 | 1,674 | 1,840 | 2,134 | 2,381 |
| | 12.9 | 429 | 420 | 410 | 400 | 389 | 367 | 345 | 1,287 | 1,526 | 1,750 | 1,959 | 2,153 | 2,497 | 2,787 |

Guide values for clamp forces (FM) and tightening torques (MA) for headless bolts with metric coarse-pitch threads according to DIN ISO 262 and head dimensions

for hexagon bolts according to DIN EN ISO 4014 to 4018 or fillister head bolts according to DIN EN ISO 4762, and "central" hole according to DIN EN 20 273.

Glossary

| | | | |
|-----------------------------|--|---|---|
| Output drive | Spindle components that include the tightening tool (e.g. tightening nut). | Gradient | Inclination of a tangent in the torque/ angle of turn graph. |
| Multiple connections | Minimum permissible distance between the tightening positions. | Handling device | Manually-operated, hand-held tightening modules which the worker uses to approach the tightening position and carry out the tightening operation without exerting any force. Depending on the design, the handling device can also support the reverse torque (reaction torques). |
| Working range | Permissible torque range of tightening spindle/ErgoSpin/Nexo. | IEC 61131-3 | Internationally recognized standard for programming languages of programmable logic controllers. |
| Size (BG) | Tightening spindles are available in sizes 2 – 5, the sizes cover different working ranges. | Max. output drive speed | Defined by the interaction of EC motor, planetary gearbox and output drive. |
| Block output drive | Single housing combines multiple output drive spindles for tight bolt patterns. | Measurement transducer | Spindle component that analyzes the torque, angle, and gradient and is equipped with an integrated cycle counter. |
| DVI | Digital Visual Interface – interface for the digital transfer of video data. | Redundant Measurement transducer | At least two independent measurement transducers that continually record the same parameters. |
| I/O | Input/output – I/O are discrete interfaces for sending and receiving digital signals. | Center-to-center distance | See multiple connections. |
| EC motor | Electronic Commutated motor – a brushless, and thus maintenance-free, motor. | Tightening case analysis | Analysis of torque and angle-of-turn measurements taken during tightening, on the basis of which conclusions about the tightening process and the quality of the tightening connection can be made. |
| ErgoSpin | Hand-held nutrunner from Rexroth with tool cable. | Tightening channel | Includes all components required for a tightening job: tightening spindle or ErgoSpin hand-held nutrunner, connection cable, as well as control and power electronics. |
| Spring force | The spring force of an output drive describes the force required to completely compress (F_{max}) the pre-tensioned spline shaft (F_{min}) of an output drive. | Tightening program | Controls the tightening process and is divided into various tightening steps, where tightening parameters are set. |
| Range of spring | Travel output which results from engaging the tightening module and tightening until the screw-in depth is reached. | | |
| Crowfoot wrench | Special components designed for very tight and hard-to-reach tightening positions. | | |
| Spindle bearing | Output drive component with straight spline shaft which supports the tightening tool (e.g. tightening nut). | | |

| | | | |
|------------------------------|--|----------------------------|--|
| Tightening spindle | Comprises an output drive unit, measurement transducer and a gearboxmotor combination for the drive and is used with hand-held and automatic tightening tasks. | Offset output drive | Output drive component for tight center to center distances where the spline shaft and drive unit are offset. |
| Tightening station | Hand-held, manually-operated, or automatic tightenings are carried out on a tightening station. It can be a part of an assembly line. | Feed output drive | Output drive component for deep-seated tightening positions (e.g. motor plugs). |
| Tightening position | Refers to the defined location where the tightening job is performed using a tightening channel and a tightening program. | Tool mount | Interface between the tightening spindle and tool. For example, a square is a typical tool mount for a tightening nut as a tool. |
| Tightening system | A complete system with all of the tightening channels that are needed to carry out the defined tightening case. It communicates with a superior controller. | Angle head | Output drive components which are used from above, usually on the hand-held nut-runner, if there is limited space available (e.g. inner housing tightening). |
| IP54 protection class | Suitability of components for certain ambient conditions, e.g. for industrial systems. IP54 refers to the protection against splash water and dust. | Feed gripper | Component used to store and supply bolts to the tightening tool. |
| Socket tray | Container for various tool inserts. Corresponding tightening programs are activated when the tools are removed | | |
| Controllers | Controls and monitors the tightening process or exchanges data with superior controllers. | | |
| System Stick | A USB stick included in the scope of delivery that contains, among other things, the installation program for the BS350 Operating System and the system documentation. | | |
| Avg. efficiency | Quotient calculated from output drive performance and drive performance. The output drive performance and drive performance depend on the speed and torque, which is why efficiency is not constant. | | |

Bosch Rexroth AG

Fornsbacher Straße 92
71540 Murrhardt, Germany
www.boschrexroth.com/tightening

Questions?

Contact our tightening experts:

rfq.jt@boschrexroth.de

Further information online:



Online Product Catalog

Besides of the CAD data, here you can find the firmware service packs for downloading:
www.boschrexroth.com/tightening



Rexroth Media Directory

Here is your 24/7 source for promotional media and technical documentation. Search and download information:
www.boschrexroth.com/mediadirectory

© This document and the data, specifications and other information contained therein are the exclusive property of Bosch Rexroth AG. Reproduction or transfer to third parties is not permitted without their consent.

The data specified above only serve to describe the product. As our products are constantly being further developed, no statements concerning a certain condition or suitability for a certain application can be derived from our information. The information given does not release the user from the obligation of own judgment and verification. It must be remembered that our products are subject to a natural process of wear and aging.

Document no.: 72804
Material no.: R999000049 (2018-11)
© Bosch Rexroth AG 2018
Subject to revisions!
Printed in Germany





Tightening Systems