

Plastic plain bearings

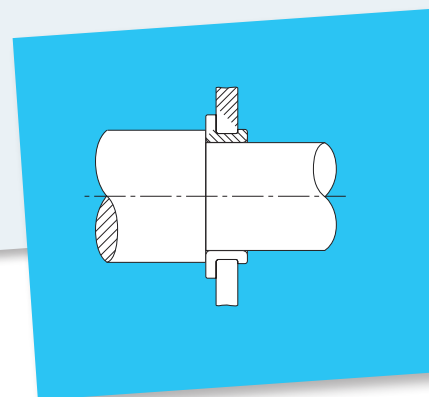
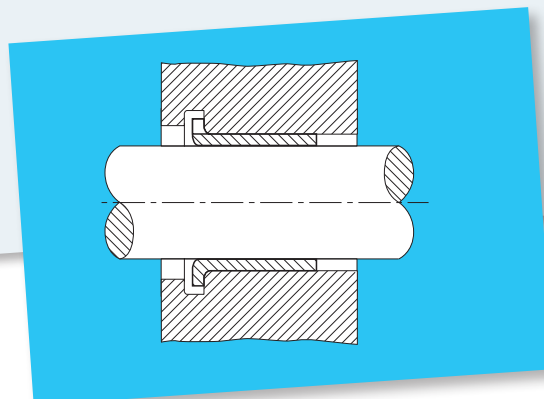
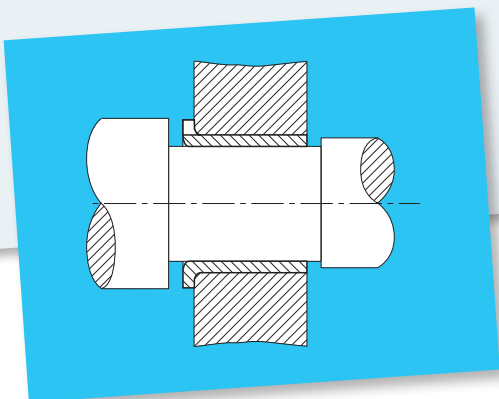

Content	3
Introduction	4
Properties	5
Friction and wear	6
Design options and dimensions	9
Calculating the bearing load capacity, nominal life and clearance	11
Mounting instructions	17
Lubrication	19
Notes	19

Plastic plain bearings with compensation gap

Introduction

Plain bearing materials have to meet very stringent demands in terms of sliding capacity, toughness, resistance to wear, compression and heat as well as to lubricants and chemicals. Polyamides, the materials used to manufacture Plastic Plain Bearings, satisfy these requirements to a high degree.

If sufficient quantities are ordered, Rexroth can also supply other thermoplasts on special request.

Properties of polyamide 6.6 as a bearing material

Since the majority of plastic plain bearings are manufactured from polyamide 6.6 and very good test results have been obtained with this material, it seems appropriate to give a brief description of its properties at the outset.

Mechanical properties

The compression strength of polyamide 6.6 lies at around 6 000 N/cm². Experience has shown that average contact pressures of up to 2 500 N/cm² are permissible when the sliding velocity is not too high. The elongation after fracture is about 120- 220%. This is the measure of toughness. Tough plastics stand out for their high wear resistance.

Compared to metallic materials, polyamide 6.6 has a very high deformation capacity. This property is a favorable one in plastic plain bearings, which cannot be sealed absolutely dust-free.

Any dirt particles penetrating the bearing will become embedded in the plastic and rendered virtually harmless. Polyamide 6.6 also has a very high internal mechanical damping capacity and can thus effectively absorb shaft vibrations. The damping properties of polyamide 6.6 peak at temperatures between 50 and 80° C, the range in which bearings are most commonly used. This is the reason for the smooth and quiet running characteristics of plastic plain bearings.

Compared to metallic materials, polyamides have a low modulus of elasticity. This is an advantage in terms of the maximum load capacity of the bearing material.

Since shafts under load tend to press into the bearings, better conformity is achieved along with a reduction in maximum contact pressure and edge pressure.

Thermal properties

Polyamide 6.6 is a thermoplast, i.e. the material softens on heating and eventually melts. The melting point lies around 250-255°C. Wherever possible, the continuous thermal load of polyamide plain bearings should not be allowed to rise above 80°C.

Sustained exposure to higher temperatures renders the material brittle, and the bearings wear out very quickly as a consequence.

Polyamide 6.6 has a linear thermal expansion coefficient six times higher than that of metallic plain bearing materials. Special note should be taken of this fact when designing machinery. By contrast, the thermal conductivity of polyamide 6.6 is substantially lower than that of metals. This is of crucial importance in plastic plain bearings as their bearing capacity is in part determined by the amount of frictional heat that can be dissipated through the given wall thickness.

Absorption of moisture

The rate of absorption and release of atmospheric moisture is so low that the moisture content of saturated parts will not change significantly in the event of rapid changes in the normal climate. Any swelling is, however, easily compensated for by the special design of plastic plain bearings.

Properties of polyamide 6.6		Unit	
Density	DIN 53 479	g/cm ³	1.12-1.15
Tensile strength ¹⁾	DIN 53 455	N/cm ²	5 500-6 000
Elongation after fracture ¹⁾	DIN 53 455	%	120-220
Modulus of elasticity ¹⁾		N/cm ²	170 000
Notch impact toughness ¹⁾	DIN 53 453	Ncm/cm ²	150-200
Cone thrust hardness ^{1), 4)}		Ncm/cm ²	9 000-10 000
Elongation due to static tensile loading ²⁾			
	at 20 °C and		
	500 N/cm ² after 100h	%	0.3
	500 N/cm ² after 1000h	%	0.4
	1000 N/cm ² after 100h	%	0.7
	100 N/cm ² after 1000h	%	0.9
	2000 N/cm ² after 100h	%	1.8
	2000 N/cm ² after 1000h	%	2.3
Maximum logarithmic damping decrement	(DIN 53 445) ³		
	im Bereich 20-50	°C	0.14
	50-80	°C	0.44
Permissible continuous service temperature	Wärme	°C	80-100
	Kälte	°C	-20
Melting point		°C	250-255
Coefficient of linear thermal expansion		1/K	7 · 10 ⁻⁵
Thermal conductivity		W/K · m	0.23
Specific electrical resistance ¹⁾		Ω cm	1012
Maximum absorption of moisture at 20 °C and 65% relative humidity		%	3.4-3.8

Table 1

- 1) After 4 months storage in a normal climate 20/65 DIN 50014
- 2) After saturation with moisture at 20°C and 65% relative humidity
- 3) Dry
- 4) After 10 impressions at 250 N load

Values as supplied by manufacturer.

Chemical resistance of polyamide 6.6

Polyamide 6.6 is resistant to a great number of chemicals. Plastic plain bearings are insoluble in common organic solutions and are not attacked by the majority of weak organic and inorganic acids.

Plastic plain bearings are resistant to most of the lubricating oils and greases in use today.

Medium	Concentration %	Resistance
Aluminum chloride, aqueous	10	((1)) bis +
Formic acid, aqueous	85	O
Formic acid, aqueous	10	-
Ammonia, aqueous	10	+8
Gasoline		+
Butyric acid		+
Calcium chloride, aqueous	10	+9
Chlorine gas	100	-
Chlorine water		-
Diesel oil		+
Acetic acid, conc.		-
Acetic acid, aqueous	5	+7
Milk		+
Lactic acid, aqueous	10	+
Mineral oil		+0

Medium	Concentration %	Resistance
Sodium chloride	10	+
Sod. hydroxide sol., aqueous	10	+
Petroleum		+2
Hydrochloric acid, aqueous		-
Sulfur	2	+
Sulfuric acid, aqueous		-
Soap solution, aqueous	2	+
Silicone oil		+
Edible fat		+
Edible oil		+
Tallow		+
Water (sea, river, drinking and condensate)		+7.5
Water, hot		((1)) to ((2))
Wine		+

Table 2

- + = Resistant, no or only slight changes in weight and dimensions
- ((1)) = Limited resistance; after prolonged exposure, major changes in weight and dimensions, possible discoloration, weakening, possible slight embrittlement
- ((2)) = Not resistant; may still be usable under certain conditions (e.g. temporary exposure)
- = Not resistant; strong attack within a very short period
- O = Soluble

The figures alongside the symbols indicate the maximum increase in weight and length in %.

Example: + 11/3 = resistant; 11% max. increase in weight, 3% elongation.

Friction and Wear

When mated with steel or other polyamides, polyamide 6.6 exhibits very good sliding properties and wear resistance. This is especially true in the case of dry or mixed friction. These two types of friction are defined in the usual way, i.e.

Dry friction

Lubricants are, if at all, applied once on installation to improve running in conditions.

Mixed friction

Oil lubrication, but with insufficient dynamic lubrication pressure, resulting in tearing of the lubricant film.

Coefficient of friction

This is influenced by many different factors. The average contact pressure, sliding velocity, temperature, bearing clearance, and running time, as well as the properties of the mating material, the finish of the surfaces sliding relative to each other, the quality and amount of lubricant applied, and the wall thickness of the plastic plain bearings – all of these contribute to the coefficient of friction.

Contact pressure and sliding velocity and their effect on friction

Figure 1 shows that the coefficient of friction declines rapidly with increasing bearing load. It is less dependent on the sliding velocity and decreases at a much slower rate as the sliding velocity rises.

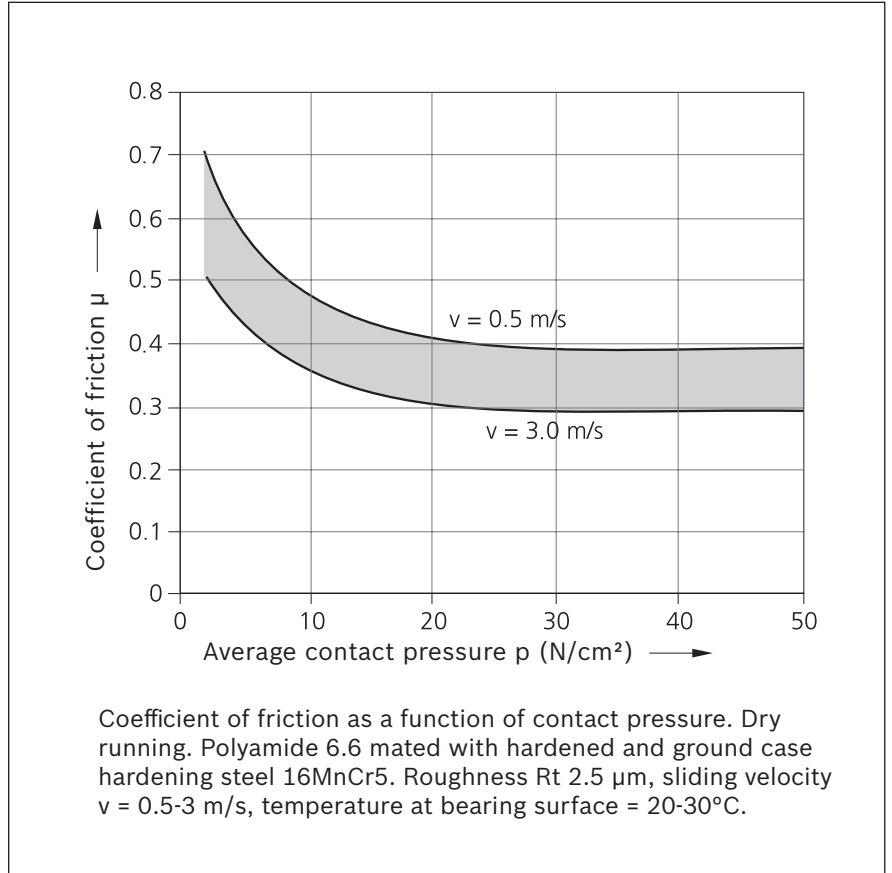

Figure 1

Roughness of the mating material and its effect on friction

Figure 2 shows that the roughness of the shaft surface has a pronounced effect on the coefficient of friction. The curve clearly illustrates that both very smooth and very rough surfaces produce high sliding friction, while the friction reaches a definite low at between 2 and 3 μm roughness.

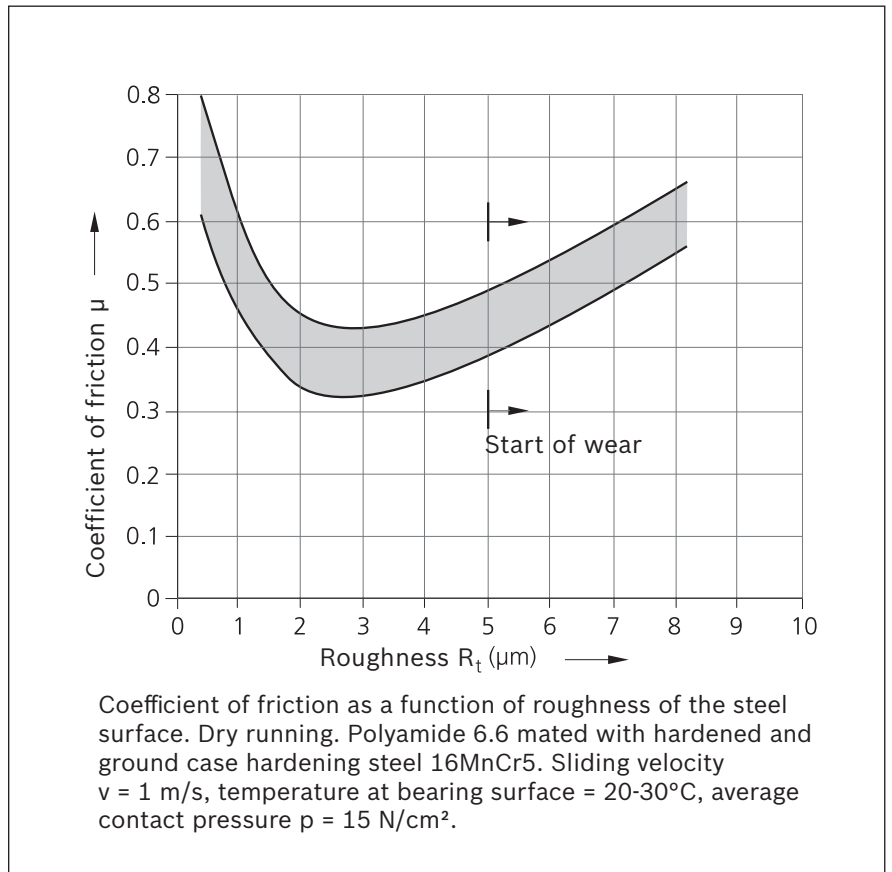

Figure 2

Time and its effect on friction

Figure 3 shows that, for dry running, the steady state value is reached after a running in period of about 5 hours. No running in period is required when the bearing is grease lubricated.

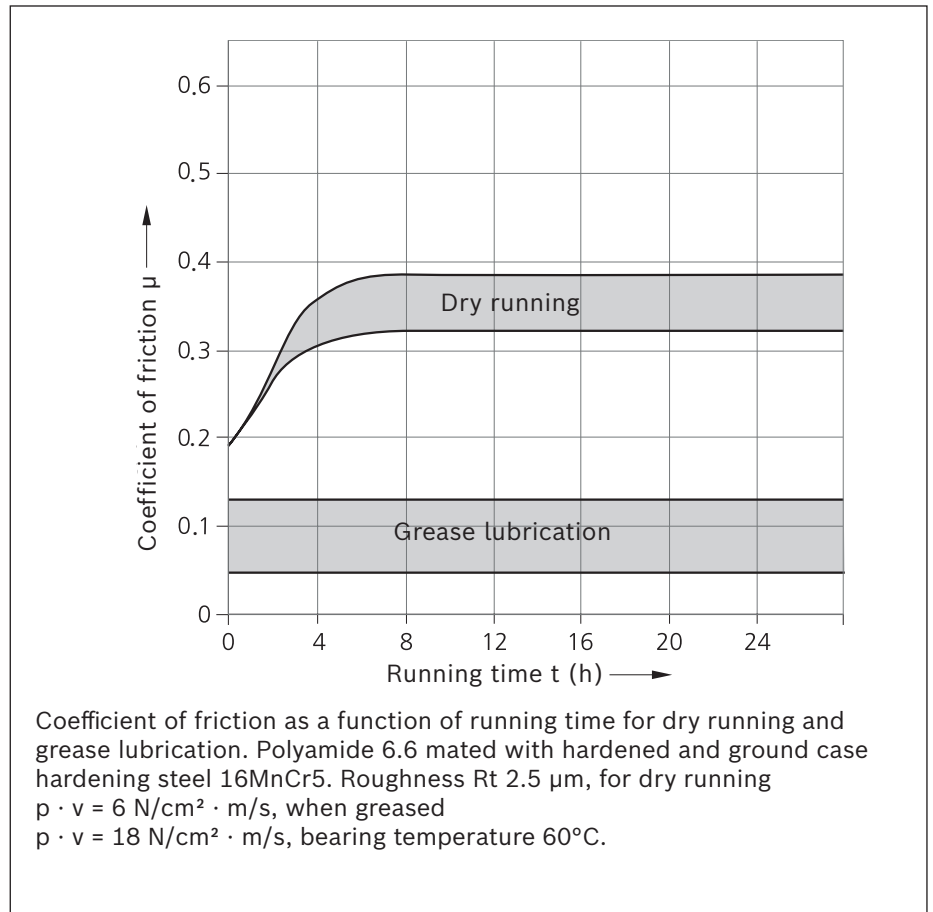

Figure 3

Coefficient of friction values

The load capacity calculations (see page 11) are based on average conditions. The following values are recommended:

Type of lubrication	Coefficient of friction μ
Dry running	0.35
Non-recurring grease lubrication	0.12
Sustained release grease lubrication	0.09
Oil mist	0.09
Water lubrication (mixed friction)	0.04
Oil lubrication (mixed friction)	0.04

Table 3

Wear

Provided the wall thickness has been properly dimensioned, the bearing temperature does not exceed 80°C, and the shaft surface has a roughness of 2 to 4 μm with a surface hardness of 45 Rockwell C, the wear on plastic plain bearings will be virtually undetectable.

Softer shafts, smoother or rougher surfaces (Figure 2) or bearing temperatures above 80°C will cause a higher wear rate. If plastic plain bearings are to run under corrosive conditions, corrosion-resistant steel is a more appropriate choice for the shaft material than brass or bronze, as the latter materials tend to wear too rapidly.

Temperature and its effect on wear

Figure 4 shows that the rate of bearing wear is minimal up to a temperature of 80°C. At temperatures above 80°C, plastic plain bearings wear very quickly as the bearing surface embrittles at these high temperatures and is rapidly abraded.

Wall thickness and its effect on wear

As polyamide 6.6 is a poor thermal conductor, increasing wall thickness would cause heat to build up, with a consequent sharp rise in the bearing surface temperature. This would result in premature wearing of the bearings.

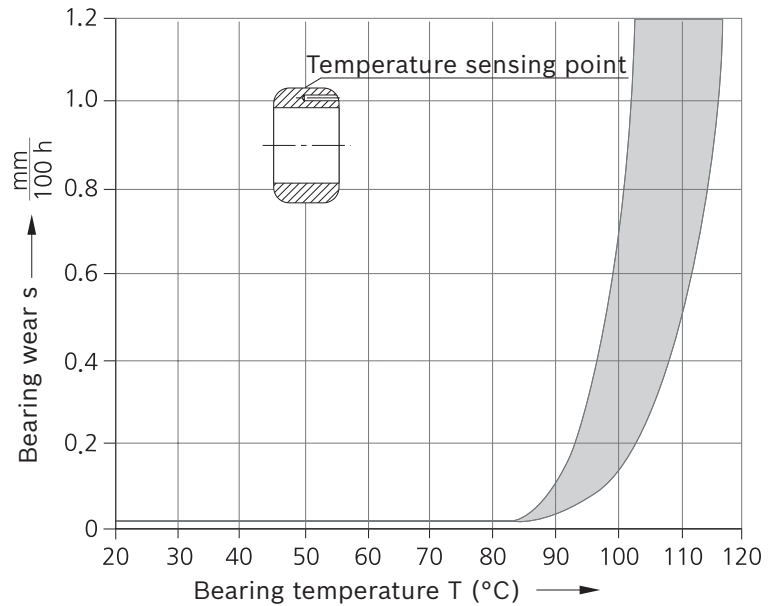

Bearing wear as a function of bearing temperature.
Polyamide 6.6 mated with hardened and ground steel.

Figure 4

Design options and dimensions

Plastic plain bearings are manufactured in two designs.
Type R1320-5 .. and Type R1320-7..

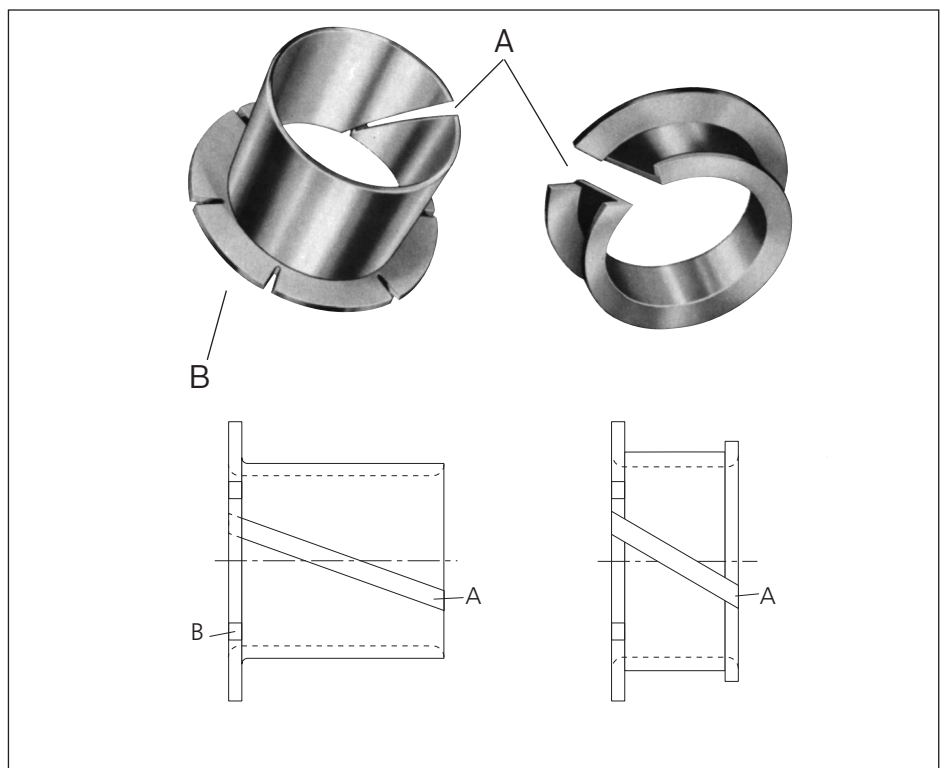

Figure 5

Both types have been provided with a so-called compensating gap "A" in the longitudinal axis (see Figure 5). This compensating gap balances out almost all dimensional deviations due to absorption of moisture or changes in temperature. It also accumulates lubricant in greased bearings and helps to distribute the grease throughout the bearing.

Type R1320-5.. is a plastic plain bearing with one collar. The collar is intended as a simple holding device to guard against axial shifting, but it can also take up any arising axial forces. The radial slits "B" (Figure 5) in the collar have the same function as the compensating gap "A".

Type R1320-7.. is equipped with two collars of different size. This type was specifically designed for installation in metal bearing plates up to a maximum thickness of 2 mm. The two collars ensure that the plastic plain bearing remains securely lodged within the bearing plates. When installing this type, care must be taken to fit the bearing with the large collar on the side subjected to axial forces.

The compensating gap "A" allows plastic plain bearings to be compressed until the smaller collar can be easily twisted into the mounting bore of the metal bearing plate. When installing the bearing, make sure the gap is uppermost and insert the bearing into the mounting bore beginning with the left-hand end. When the bearing is twisted to the right it will automatically draw itself the bore.

If they have been installed correctly, plastic plain bearings will recover their shape and sit snugly within the plate.

Dimensions

Type R1320-5..-00

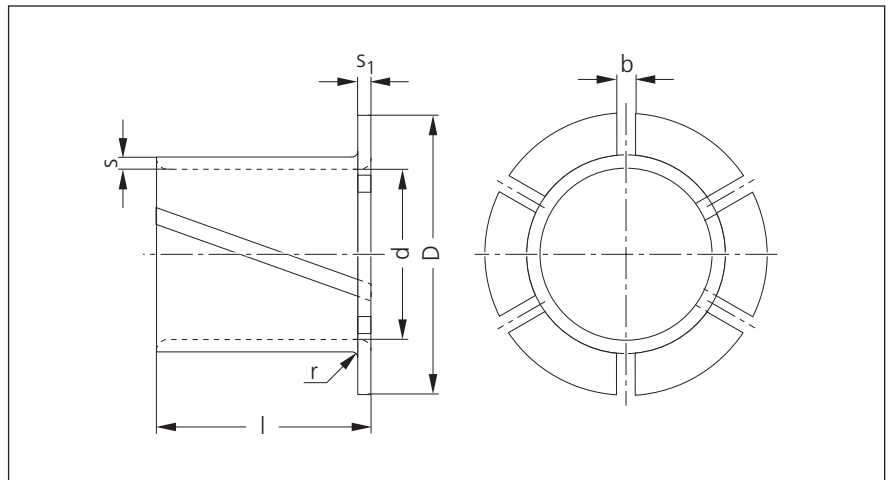

Part number	Dimensions (mm)									
	d	D	l 1)	s	Permissible deviation	s ₁	Permissible deviation	b	r	
R132050400	4	7	4.6	0.6	-0.06	0.6	-0.06	0.9	0.25	
R132050500	5	8	5.6	0.6	-0.06	0.6	-0.06	0.9	0.25	
R132050600	6	9.5	6.6	0.6	-0.06	0.6	-0.06	0.9	0.25	
R132050800	8	12	8.8	0.8	-0.06	0.8	-0.06	1.3	0.4	
R132051000	10	15	10.8	0.8	-0.06	0.8	-0.06	1.3	0.4	
R132051200	12	18	12.8	0.8	-0.07	0.8	-0.06	1.3	0.4	
R132051400	14	21	14.8	0.8	-0.07	0.8	-0.06	1.3	0.4	
R132051600	16	24	16.8	0.8	-0.07	0.8	-0.06	1.3	0.4	
R132052000	20	30	20.8	0.8	-0.08	0.8	-0.06	1.3	0.4	
R132052500	25	37.5	26.2	1.2	-0.08	1.2	-0.06	1.8	0.5	

Table 4

1) Use length $l-s_1$ for calculations

Type R1320-7...-00

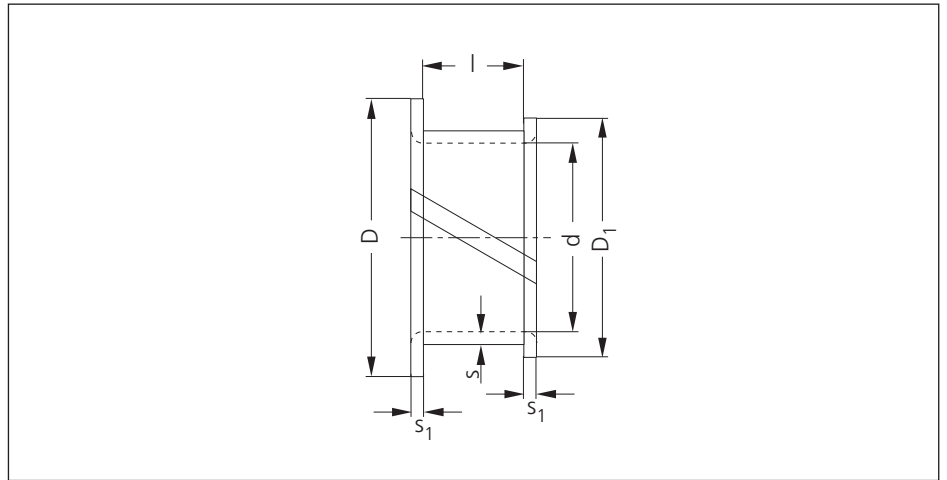

Part number	Dimensions (mm)								
	d	D	D ₁	l	s	Deviation	s ₁	Deviation	
R132070300	3	6	4.8	2	0.6	-0.06	0.6	-0.06	
R132070400	4	7	5.9	2	0.6	-0.06	0.6	-0.06	
R132070500	5	8	6.8	2	0.6	-0.06	0.6	-0.06	
R132070600	6	11	7.8	2	0.6	-0.06	0.6	-0.06	
R132070800	8	13	10.4	2	0.8	-0.06	0.8	-0.06	
R132071000	10	15	12.4	2	0.8	-0.06	0.8	-0.06	
R132071200	12	17	14.4	2	0.8	-0.07	0.8	-0.06	

Table 5

Calculating the bearing load capacity, nominal life and clearance

When calculating the load capacity and the nominal life of plastic plain bearings, the following factors, among others, have to be taken into account:

- Sliding velocity
- Average contact pressure
- Frictional heat
- Wear
- Bearing clearance

The average contact pressure is calculated using the equation

$$p = \frac{F}{l \cdot d} \quad [\text{N/cm}^2] \quad (1)$$

F = bearing load (N)

l = width of the plastic plain bearing (cm). For type R1320-5.. the value l should be substituted by $(l-s_1)$.

d = bearing diameter (cm)

At low sliding velocities, the average contact pressure is 2 500 N/cm². This value is used as p_{perm} in the load capacity calculations.

$$P_{perm} = 2\,500 \text{ N/cm}^2 \quad (2)$$

For bearings with higher sliding velocities, P_{perm} has to be limited according to equation (5) or (6).

The heat developing in the bearing is calculated as follows from the work consumed by friction:

$$Q_1 = p \cdot l \cdot d \cdot v \cdot \mu \quad (3)$$

v = sliding velocity (m/s)

μ = coefficient of friction

The values for the coefficient of friction can be taken from Table 3.

The heat that can be dissipated from the bearing due to the temperature differential is partly dissipated through the plastic plain bearing and partly through the steel shaft.

$$Q_2 = K_1 \cdot \frac{\pi \cdot l \cdot d}{4 \cdot d} \cdot \lambda \cdot \Delta\vartheta + K_2 \cdot \frac{2\pi \cdot d^2}{4 \cdot d} \cdot \lambda_s \cdot \Delta\vartheta \quad (4)$$

K_1 and K_2 are dimensionless factors indicating the way in which the bearing heat components dissipated through the plastic plain bearing and the shaft are affected by the bearing construction. Generally the following values can be expected:

$$K_1 = 1/2$$

$$K_2 = 1/24$$

λ = thermal conductivity of polyamide = 0.23 W/K · m

λ_s = thermal conductivity of steel = 46 W/K · m

s = wall thickness of plastic plain bearings

$\Delta\vartheta$ = temperature differential (K or °C).

Equations (3) and (4) are used to derive the conditions under which the frictional heat can be dissipated from the bearing at a temperature differential of $\Delta\vartheta$:

$$(p \cdot v)_{perm} = \frac{K_1 \cdot \pi \cdot \lambda \cdot \Delta\vartheta}{\mu \cdot s} + \frac{K_2 \cdot \pi \cdot \lambda_2 \cdot \Delta\vartheta}{\mu \cdot 2 \cdot l} \quad (5)$$

This calculation cannot be applied to bearings with continuous water or oil lubrication.

Equation (5) is a quantity equation.

This results in the following numerical value equation:

$$(p \cdot v)_{perm} \leq 37.3 \cdot 10^{-3} \frac{\Delta\vartheta}{\mu} \cdot \left(\frac{1}{s} + \frac{8.33}{l} \right) \quad [\text{N/cm}^2 \cdot \text{m/s}] \quad (6)$$

μ = coefficient of friction (as per table 3)

s = wall thickness of plastic plain bearings in mm (tables 4 and 5)

l = width of plastic plain bearings in mm. (For type R1320-5.. the value l should be substituted by $(l-s_1)$).

The $p \cdot v$ values thus obtained for plastic plain bearings at an ambient temperature of 20°C or $\Delta\vartheta$ of 60°C can be read off from table 6.

At higher ambient temperatures, the $\Delta\vartheta$ value reduces, as does the $p \cdot v$ value in accordance with equation (6).

Permissible $p \cdot v$ values for an ambient temperature of 20°C

Part number	$(p \cdot v)_{\text{perm.}} \left[\frac{\text{N}}{\text{cm}^2} \cdot \frac{\text{m}}{\text{s}} \right]$		
	Dry running	Non-recurring grease lubrication	Continuous grease lubrication
R132050400	24	70	93
R132050500	21	62	83
R132050600	20	57	76
R132050800	15	43	57
R132051000	13	39	52
R132051200	12	36	48
R132051400	12	34	46
R132051600	11	33	44
R132052000	11	31	42
R132052500	7	21	29
R132070300	37	110	150
R132070400	37	110	150
R132070500	37	110	150
R132070600	37	110	150
R132070800	35	100	135
R132071000	35	100	135
R132071200	35	100	135

Table 6

The specific bearing pressure p in N/cm^2 can be read off from the chart (Figure 6) for the circumferential velocity relating to the permissible $p \cdot v$ value.

A specific bearing pressure of $p = 1\,400 \text{ N}/\text{cm}^2$ was selected for the static load capacity.

Bearing wear

If the bearing temperature does exceed 80°C, hardened and ground steel shafts are used, and the bearing wear is virtually undetectable. As the wear "S" increases when the temperature climbs above 80°C and presumably rises proportionately with the length of running time, it can be calculated as follows:

$$S = k \cdot \left(\frac{\vartheta \cdot \vartheta_0}{\vartheta_0} \right)^\chi \cdot t \quad [\text{mm}] \quad (7)$$

$k = 1/6$ (constant)

$\chi = 3$ (constant)

$\vartheta_0 = 80 \text{ °C}$

$t =$ time in hours

The maximum permissible wear rate to be expected with plastic plain bearings is

$$S = 0.2 \text{ mm} \quad (8)$$

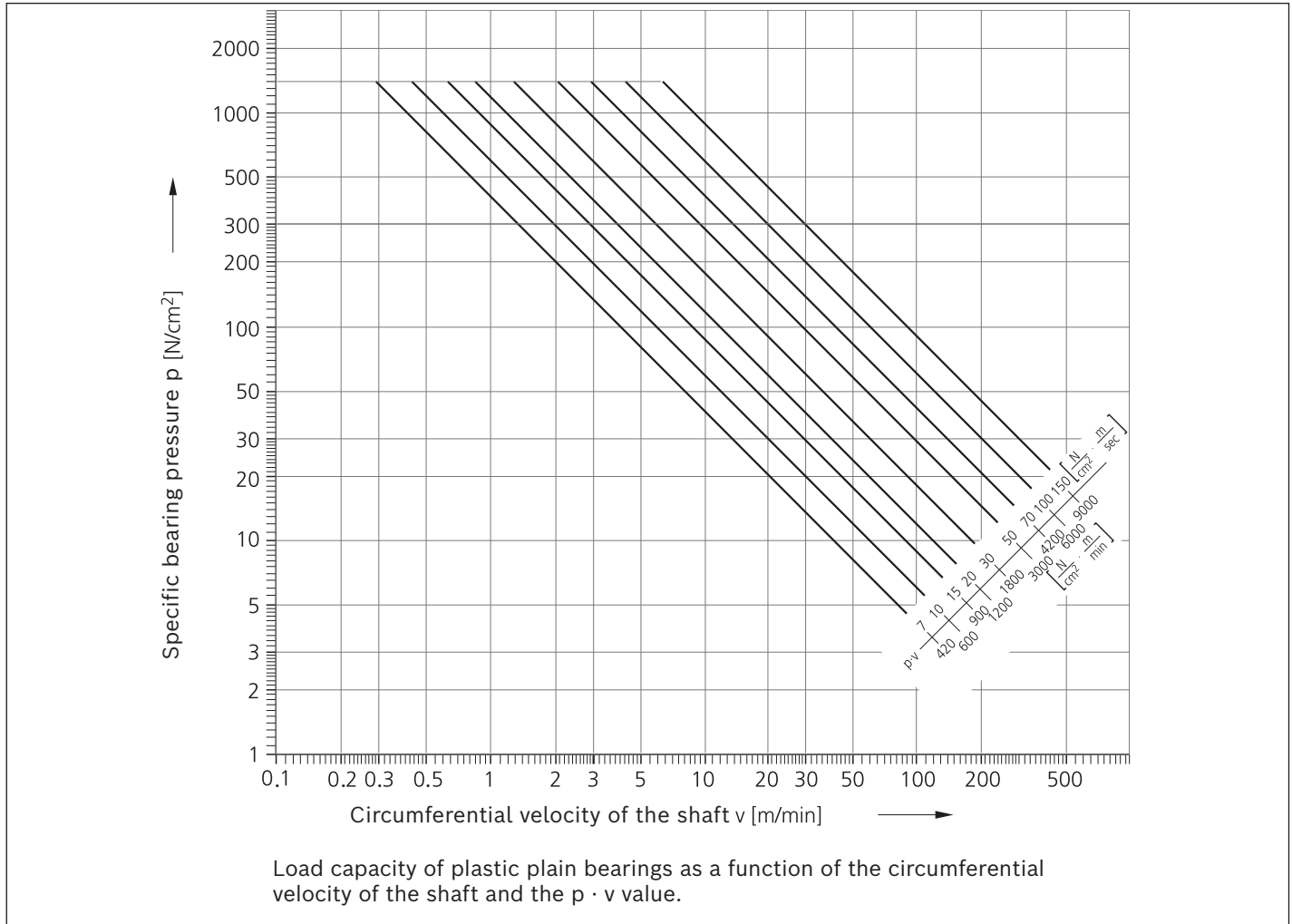

Figure 6

Nominal life

The nominal life of plastic plain bearings can be calculated from equation (7) as follows:

$$t = \frac{S_{perm}}{k \cdot \left(\frac{\vartheta - \vartheta_0}{\vartheta_0}\right)^z} \quad \text{[hours]} \quad (9)$$

This equation is valid for $\vartheta > 80^\circ\text{C}$.

Calculating the nominal life for $\vartheta < 80^\circ\text{C}$ would serve no useful purpose as the bearing wear is hardly detectable and thus not reproducible.

Bearing clearance

The bearing clearance must be dimensioned such that the bearing will not jam in the event of excessive enlargement of plastic plain bearings as a result of temperature rises or changes in the moisture content. Conversely, the clearance must not be unnecessarily wide, as this would cause irregular running characteristics. Experience has shown that, even in the worst case, there should still be a minimum clearance of

$$h_0 = 0.004 \cdot d \quad \text{[mm]} \quad (10)$$

For an increase in temperature of $\Delta \vartheta_1$ and a relative change in the linear dimensions due to a rise of ϵ_f in the moisture content, the volume of plastic plain bearings will increase by

$$\Delta V = 3 (\epsilon_f + \alpha \cdot \Delta \vartheta_1) \cdot V \quad (11)$$

ϵ_f = linear expansion factor for the moisture content:

0.003 for non water lubricated bearings

0.020 for water lubricated bearings

α = Coefficient of linear expansion according to table1 = $7 \cdot 10^{-5} \frac{1}{K}$

$$\Delta \vartheta_1 = \vartheta_{\max} - 20 \text{ } ^\circ\text{C}$$

ϑ_{\max} is the maximum temperature arising at the bearing point. This is arrived at by adding $\Delta \vartheta$ according to equation (6) to the ambient temperature. ϑ_{\max} should not exceed 80°C.

If the ambient temperature is 20°C, then, then $\Delta \vartheta_1 = \Delta \vartheta$.

Equation (11) applies when expansion is not restricted in any direction. However, even assuming that the full volume change will occur and that the material will expand exclusively to the detriment of the bearing clearance, the calculation still provides an additional safety margin. The clearance would in this case narrow by

$$3 \cdot s \cdot (\epsilon_f + \alpha \cdot \Delta \vartheta_1)$$

Taking the minimum permissible clearance into consideration and remembering that a great proportion of the change in volume is taken up by the compensating gap in plastic plain bearings, the minimum permissible clearance can be calculated as follows:

$$h = 0.004 \cdot d + 3s (\epsilon_f + \alpha \cdot \Delta \vartheta_1) \text{ [mm]} \quad (12)$$

Load capacity

Type R1320-5..-00 Radial load capacity [N]

Part number	Static load capacity	50 min ⁻¹			100 min ⁻¹			250 min ⁻¹		
		Dry running	Grease lubrication		Dry running	Grease lubrication		Dry running	Grease lubrication	
			once	cont.		once	cont.		once	cont.
	(N)									
R132050400	220	220	220	220	180	220	220	70	210	220
R132059599	359	350	350	350	200	350	350	80	235	315
R132050600	500	450	500	500	225	500	500	90	260	350
R132050800	900	450	900	900	225	655	870	90	260	350
R132051000	1 400	520	1 400	1 400	255	745	990	100	300	395
R132051200	2 000	565	1 650	2 000	285	825	1 100	115	330	440
R132051400	2 750	630	1 820	2 470	315	910	1 230	125	365	495
R132051600	3 600	690	2 020	2 690	345	1 010	1 340	140	405	540
R132052000	5 600	815	2 370	3 210	410	1 180	1 600	160	475	640
R132052500	8 750	705	2 060	2 770	350	1 030	1 380	140	410	550

Table 7

The axial load that can be taken up by the bearing collar must never exceed 25% of the radial load capacity. The shaft collar diameter must also correspond to dimension "D" in Table 4.

The values given are valid for a bearing temperature of $\leq 80^\circ\text{C}$ and an ambient temperature of 20°C.

Type R1320-7..-00 Radial load capacity [N]

Part number	static load capacity	50 rpm				100 rpm			250 rpm		
		Dry running	Grease lubrication		Dry running	Grease lubrication		Dry running	Grease lubrication		
			once	cont.		once	cont.		once	cont.	
	(N)										
R132070300	85	85	85	85	85	85	85	57	85	85	
R132070499	112	112	112	112	112	112	112	57	112	112	
R132070500	140	140	140	140	140	140	140	57	140	140	
R132070600	168	168	168	168	143	168	168	57	166	168	
R132070800	225	225	225	225	133	225	225	53	154	205	
R132071000	280	265	280	280	133	280	280	53	154	205	
R132071200	335	265	335	335	133	335	335	53	154	205	

Table 8

The axial load that can be taken up by the bearing collar must never exceed 25% of the radial load capacity. The shaft collar diameter must also correspond to dimension "D" in Table 5. The values given are valid for a bearing temperature of $\leq 80^\circ\text{C}$ and an ambient temperature of 20°C .

Calculation example

A gear drive shaft is to run in plastic plain bearings. The shaft diameter is 20 mm and the drive speed is 100 min^{-1} . Two plastic plain bearings R132052000 have been selected. The load per bearing is 1 000 N.

The bearings are to be greased once on installation. The permissible bearing wear is assumed to be 0.2 mm.

In order to achieve long service life the bearing temperature should not exceed 80°C (at 20°C ambient temperature).

The task is to check whether the chosen bearing type is adequate, what service life can be expected and what bearing clearance is required.

Average contact pressure

According to equation (1), the average contact pressure is:

$$p = \frac{F}{l \cdot d} = \frac{1\,000}{2.0 \cdot 2.0} = 250 \text{ N/cm}^2$$

Permissible $p \cdot v$ value

According to Table 6, the perm. $p \cdot v$ value for non-recurring greasing of the plastic plain bearing R132052000 is $31 \text{ [N/cm}^2 \cdot \text{m/s]}$.

$$31 \left[\frac{\text{N}}{\text{cm}^2} \cdot \frac{\text{m}}{\text{s}} \right]$$

For $p = 250 \text{ N/cm}^2$ and the permissible $p \cdot v$ value $31 \text{ [N/cm}^2 \cdot \text{m/s]}$ a circumferential velocity of 7.5 [m/min] can be read off from the chart (Figure 6).

$$p \cdot v \text{ value } 31 \left[\frac{\text{N}}{\text{cm}^2} \cdot \frac{\text{m}}{\text{s}} \right]$$

The circumferential velocity of the drive shaft is:

$$v = d \cdot \pi \cdot n = 0.02 \cdot 3.14 \cdot 100 = 6.28 \text{ m/min}$$

The calculated value is less than the value of 7.5 m/min read off from the chart, i.e. the proposed lubrication method is adequate. The actual $p \cdot v$ value is:

$$p \cdot v = 250 \cdot \frac{6.28}{60} = 26.2 \left[\frac{\text{N}}{\text{cm}^2} \cdot \frac{\text{m}}{\text{s}} \right]$$

Calculation of the actual bearing temperature $\Delta\vartheta$.

After entering the appropriate values in equation (6), the arising bearing temperature can be calculated as follows:

$$\Delta\vartheta = \frac{p \cdot v \cdot \mu}{37.3 \cdot 10^{-3} \cdot \left(\frac{1}{s} + \frac{8.33}{l}\right)}$$

According to Table 3, a value of 0.12 is to be substituted for μ

$$\Delta\vartheta = \frac{26.2 \cdot 0.12}{37.3 \cdot 10^{-3} \cdot \left(\frac{1}{0.8} + \frac{8.33}{20}\right)} = 51\text{K or } \text{C}^\circ$$

Calculating the nominal life

In this case, calculating the nominal life would not serve any useful purpose since the arising bearing temperature does not exceed 80°C.

The actual $p \cdot v$ value of

$$26.2 \left[\frac{\text{N}}{\text{cm}^2} \cdot \frac{\text{m}}{\text{s}} \right]$$

lies below the perm. $p \cdot v$ value of

$$31 \left[\frac{\text{N}}{\text{cm}^2} \cdot \frac{\text{m}}{\text{s}} \right]$$

Calculation of the required bearing clearance

According to equation (12), the required bearing clearance can be calculated as follows:

$$h = 0.004 \cdot d + 3 \cdot s \cdot (\epsilon_f + \alpha \cdot \Delta\vartheta)$$

ϵ_f is replaced by 0.003

$\alpha = 7 \cdot 10^{-5}$

$$h = 0.004 \cdot 20 + 3 \cdot 0.8 \cdot (0.003 + 7 \cdot 10^{-5} \cdot 51^\circ) = 0.096 \text{ mm}$$

The bearing clearance after mounting should be 0.096 mm. Alternatively, the housing bore should be dimensioned as follows:

$$\text{Housing bore} = (d + 2 \cdot s + h)^{H7} = (20 + 2 \cdot 0.8 + 0.096)^{H7} = 21.7^{H7}$$

Mounting instructions for plastic plain bearings

When mounting plastic plain bearings, the nominal dimension of the shaft should ideally be equal to the bearing bore "d". We recommend a tolerance of "h7".

The housing bore is then calculated using $d + 2s$ and the required bearing clearance the recommended tolerance being H7.

Alternatively, one can start with the housing bore, i.e. $d + 2s$, and go on to calculate the shaft diameter in accordance with the required bearing clearance. When installing the bearings care should be taken not to stress them, as this will prevent full compensation of any changes in volume. Plastic plain bearings should never be bonded to shafts or in the housing.

Mounting examples

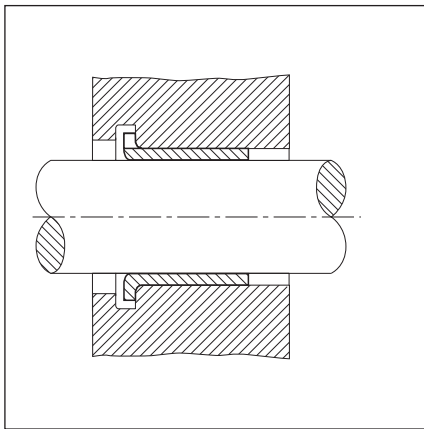

Figure 7: Cylindrical shaft. The collar of the plastic plain bearing snap-fits into a groove milled into the housing. The groove must be wider than dimension s_1 as per Table 4.

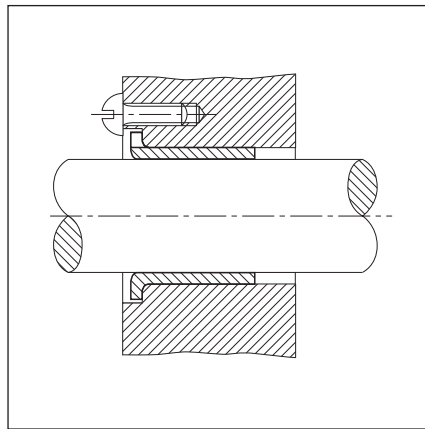

Figure 9: Cylindrical shaft. Axial retention by means of a screw. The recess in the housing must be deeper than dimension s_1 as per Table 4.

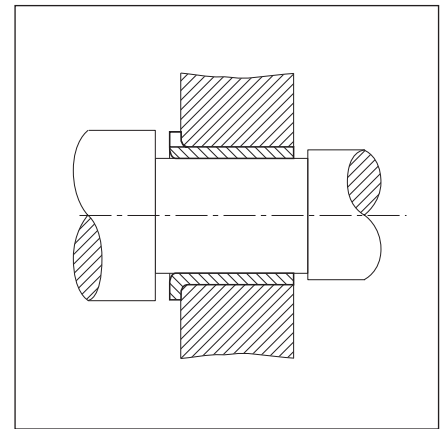

Figure 11: Cylindrical housing bore. Axial retention by means of a recessed shaft with large collar on one side. Absorption of axial forces possible.

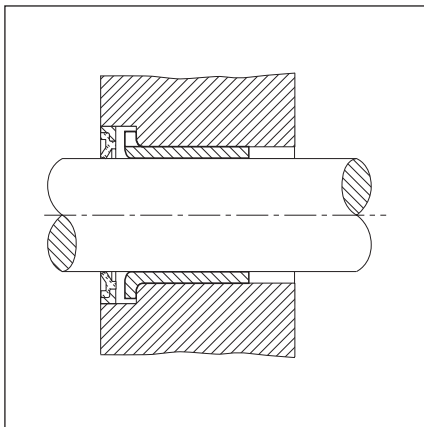

Figure 8: Cylindrical shaft. Axial retention by means of end seal. The recess in the housing must be deep enough to ensure that the collar of the plastic plain bearing will not be pinched.

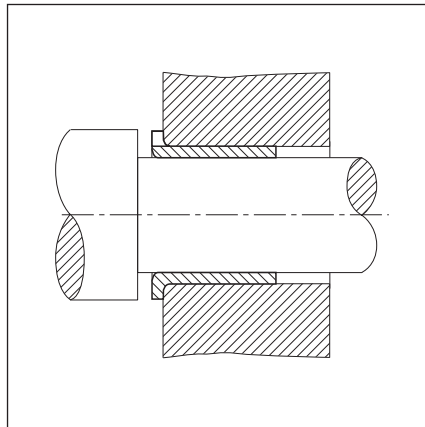

Figure 10: Cylindrical housing bore. Axial retention by means of the collar in the stepped shaft. Absorption of axial forces possible.

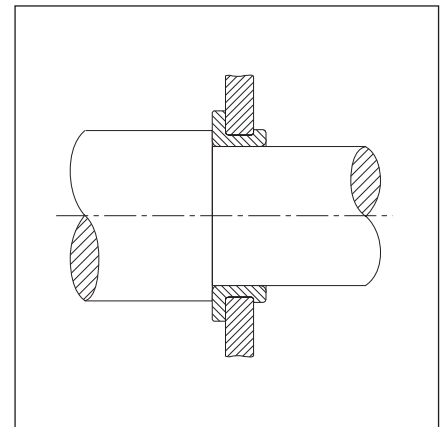

Figure 12: Type R1320-7.. with stepped shaft. The larger shaft diameter is on the side of the larger-diameter collar of the plastic plain bearing. Absorption of axial forces possible.

Mounting examples

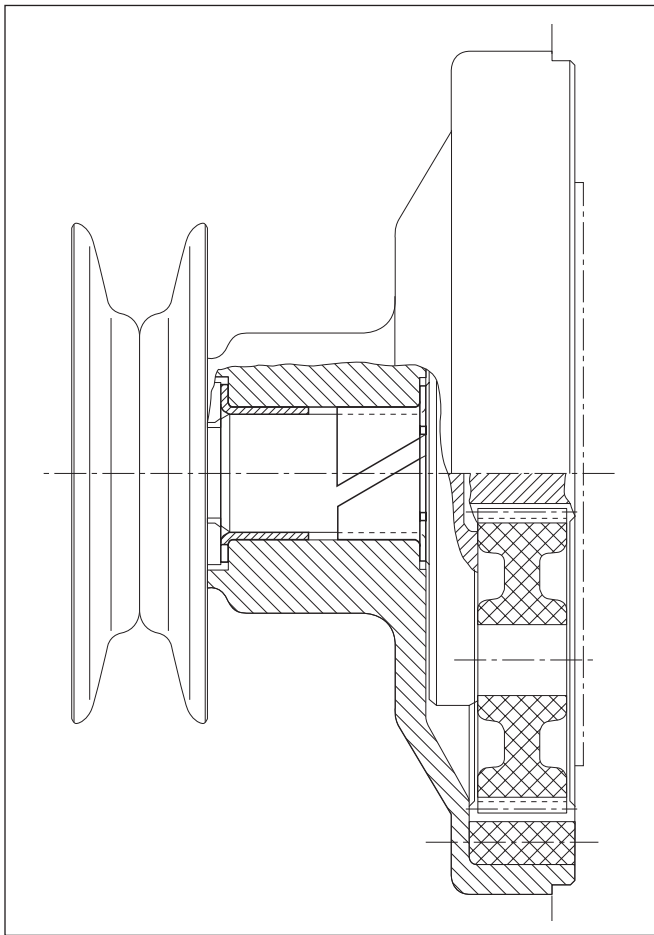

Figure 13: Gear for washing machine with plastic plain bearing type R1320-5..
 Input speed 1 330 min⁻¹
 Output speed 130 min⁻¹
 Drive torque 520 Ncm
 Belt tension on belt pulley 400 N
 $p \cdot v_{\max} = 64 \text{ N/cm}^2 \cdot \text{m/s}$

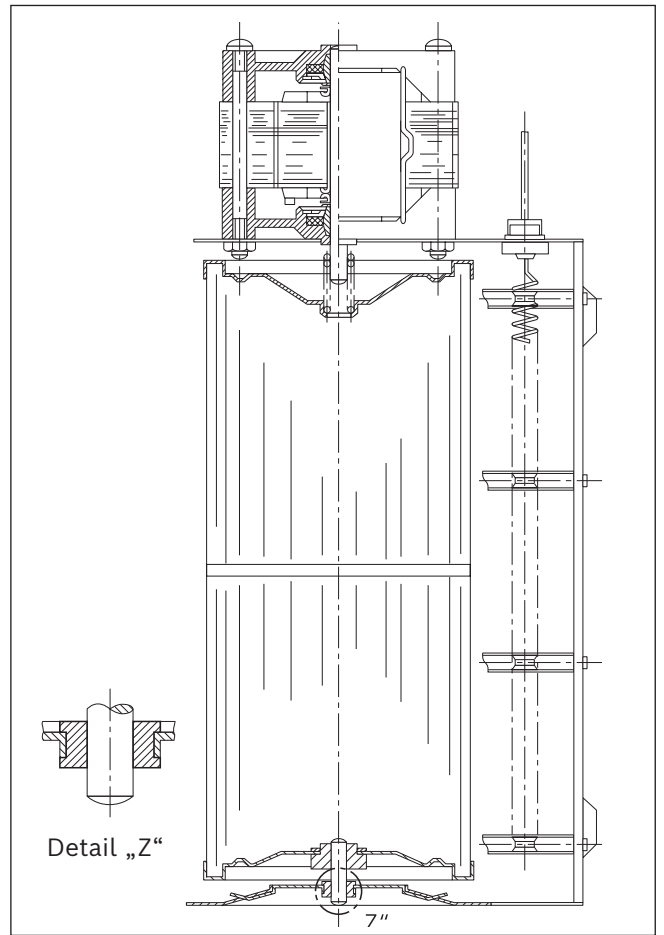

Figure 15: Cross flow fan with plastic plain bearing type R1320-7..
 Speed ca. 1 600 min⁻¹
 Load very low
 Temperature max. 85 °C

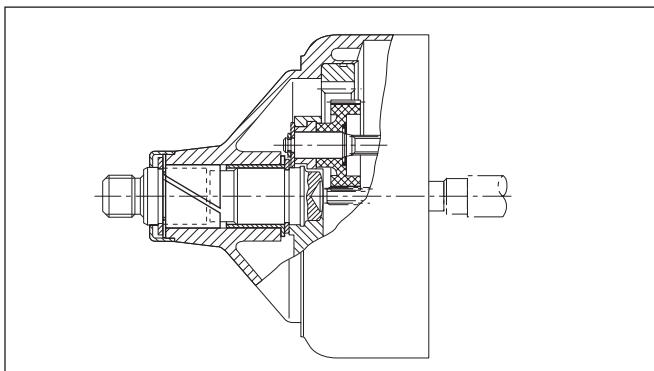

Figure 14: Gear for ironing machine with plastic plain bearing Type R1320-5..
 Input speed 1 400 min⁻¹
 Output speed 5.83 min⁻¹
 Drive torque 20 Nm
 $p \cdot v_{\max} = 2.8 \text{ N/cm}^2 \cdot \text{m/s}$

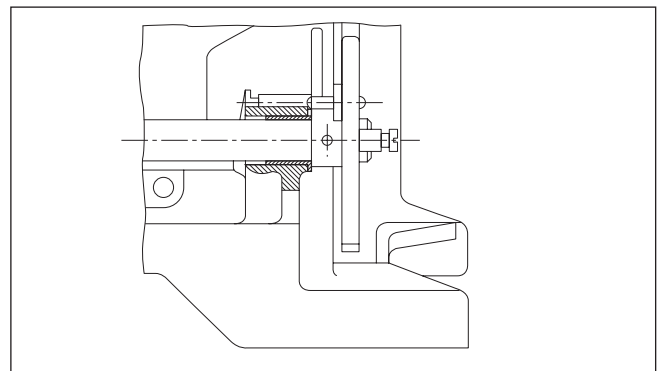

Figure 16: Typewriter shift shaft fitted with a plastic plain bearing Type R1320-5..

Lubrication of plastic plain bearings

Plastic plain bearings are ideally suited for bearing points where the bearings have to be installed either without or with only a minimal quantity of lubricant, or which cannot subsequently be relubricated.

Wherever possible, plastic plain bearings should be greased or oiled on installation as this will considerably prolong their service life..

The recommended lubricants are:

Grease: saponified lithium, drop point approx. 185°C, worked penetration approx. 265-295 mm · 10-1, with anti-corrosion and anti-aging additives

Oil: lube oil SAE 10 or SAE 30

For dry running bearings, very good results have been obtained by treating the metal parts with molybdenum sulfide.

Notes

This catalog offers an opportunity to all interested machine designers to check whether low-cost plastic plain bearings can be substituted for expensive metal plain bearings, which often also call for more sophisticated structural designs.

Our technical services staff will be happy to advise you on this subject.

The calculations for load capacity, nominal life and bearing clearance were based on the publication "Polyamide als Gleitlagerwerkstoffe" (Polyamides as plain bearing materials) by Dr.-Ing. H. Hachmann and Ing. E. Strickle of the BASF company. We used the equations given in this paper to perform the calculations for our tests.

Bosch Rexroth AG

Ernst-Sachs-Straße 100
97424 Schweinfurt, Deutschland
Tel. +49 9721 937-0
Fax +49 9721 937-275
www.boschrexroth.com

Ihre lokalen Ansprechpartner finden Sie unter:

www.boschrexroth.com/contact

