

Ball rail systems BSCl

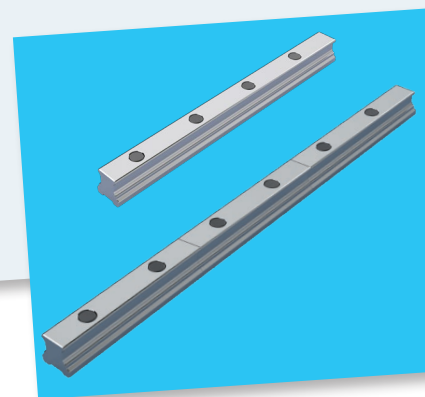
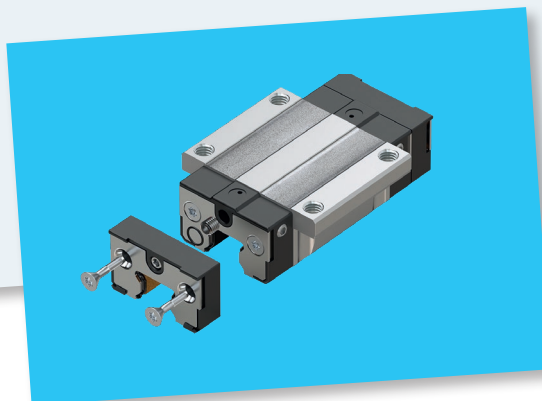
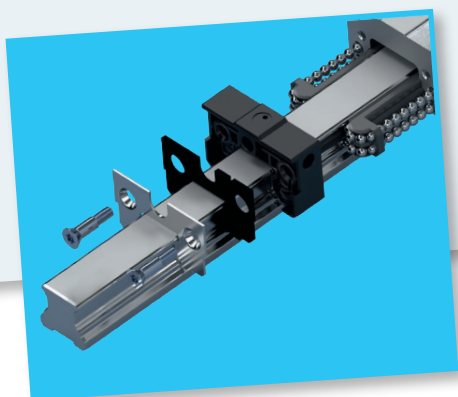
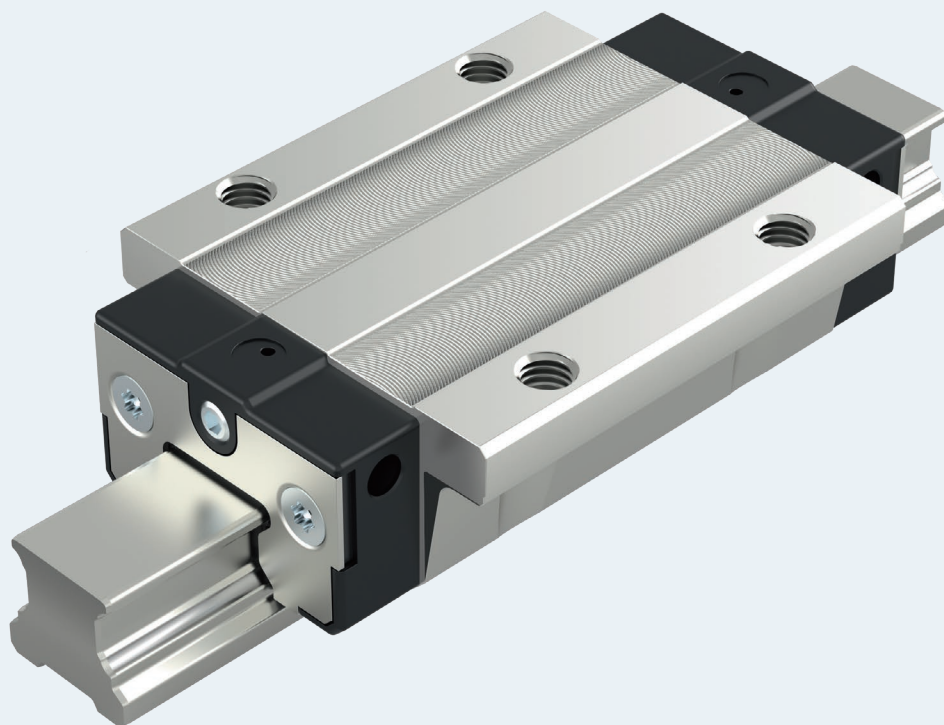

The Ball Rail System Compact Line BSCL

The new ball rail system BSCL (Ball Rail Systems Compact Line) complements the existing range of linear guides and provides application-specific performance for the middle performance and price segment. Its performance data fulfills the requirements of standard tasks and complements the high-precision BSHP series.

BSCL ball guide rails are available in six formats, six runner block types, three preload classes and three accuracy classes (N, H, P).

In the case of this series too, rails and runner blocks of the respective sizes can be combined as required, with super-fast delivery from stock to anywhere in the world. A peculiarity of the BSCL linear guides: Guide rails can be shortened to the desired length by using simple tools without the need for costly end machining.

With a new structural design and significantly reduced use of materials, Rexroth has achieved an outstanding, application-oriented price-performance ratio.

Connection elements are available for special ambient conditions.

With the expanded product portfolio, Bosch Rexroth can cater for all requirements economically.

Contents

The Ball Rail System Compact Line BSCL	2	Instructions for mounting, ball runner block and ball guide rail	54
Contents	3	General instructions for mounting	54
At a glance	4	Installation tolerances	55
<hr/>		Composite ball guide rails	57
General product information	5	Fastening	58
Product description	5	<hr/>	
Ball runner block formats	6	Lubrication	64
Ball runner blocks with load capacities and load moments	6	Notes on lubrication	64
Ball runner block accessories	7	Lube fittings	65
Ball guide rails	7	Starting up lube fittings	66
Notes	8	Lubricants	67
Selection of a linear guide according to DIN 637	10	Initial lubrication and relubrication	68
General technical data and calculations	12	Relubrication intervals	69
System preload	20	Minimum amount, minimum piston distributor size	70
Accuracy classes	22	Lubrication with central lubrication systems	71
<hr/>		<hr/>	
Ball runner block made of steel	24	Maintenance	72
Ball runner block ordering example	24	<hr/>	
FNS – flanged, normal, standard height – R205A	26	Further information	74
FLS – flanged, long, standard height – R205B	28	<hr/>	
SNS – slimline, normal, standard height – R205C	30		
SLS – slimline, long, standard height – R205D	32		
SNH – slimline, normal, high – R205E	34		
SLH – slimline, long, high – R205F	36		
<hr/>			
Ball guide rails made of steel	38		
Ball guide rail ordering example	38		
SNS – with plastic caps – R2055	40		
<hr/>			
Accessories for ball runner blocks and ball guide rails	42		
Overview – accessories	42		
Cover plate wiper	43		
Front seal	44		
Seal kit	45		
Front lube units	46		
Lubrication adapter	49		
Lube nipple, lube fittings	50		
Lube fittings, O-rings	52		
Plastic caps	53		
Cardboard box opener	53		

At a glance

Six runner block formats made of steel in accordance with ISO 12090-1

FNS

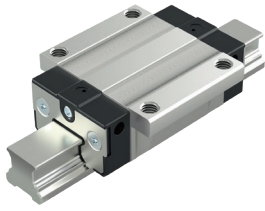

SNS

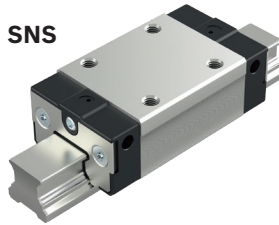

SNH

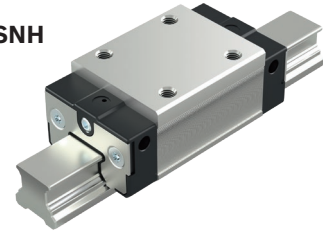

FLS



SLS

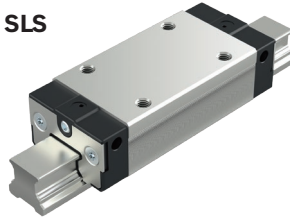

SLH

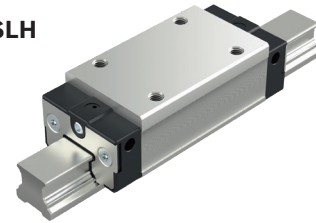

FNS = Flanged, normal, standard height
 FLS = Flanged, long, standard height
 SNS = Slimline, normal, standard height

SLS = Slimline, long, standard height
 SNH = Slimline, normal, high
 SLH = Slimline, long, high

Six sizes from 15 to 45



Size 15



Size 20



Size 25

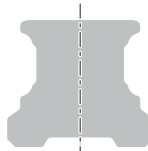

Size 30

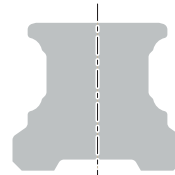

Size 35

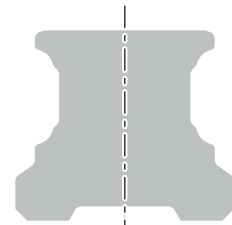

Size 45

Three accuracy classes:

N (normal)

H (high)

P (precision)

Three preload classes:

C0 (without preload)

C1 (moderate preload)

C2 (medium preload)

Guide rails for bolting from above with plastic caps:

Ball guide rails BSCL can be supplied as factory lengths or cut-to-size either in one or more parts (detailed descriptions can be found in the chapter "Ball guide rails").

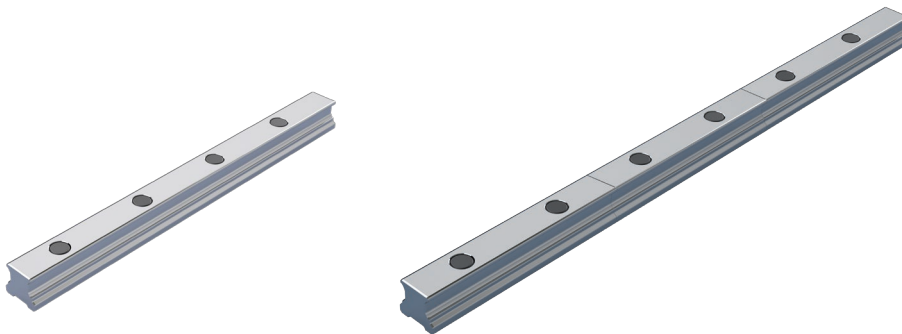

Product description

TOP logistics thanks to interchangeability and ball guide rails in factory lengths

- ▶ Ball guide rails and ball runner blocks are precisely manufactured in the ball raceway sector to allow runner blocks and ball guide rails of the same size to be combined not only within but also beyond the respective accuracy class
- ▶ Ball guide rails can be ordered in factory lengths and shortened to the desired length without costly end machining, also at the customer's location
- ▶ A market-oriented product portfolio and the interchangeability of ball guide rails and ball runner blocks allow deliveries to be made on time from stock

O-arrangement of the raceways

- ▶ Four-row profiled rail system in O-arrangement. Low amount of friction due to 2-point rolling contact
- ▶ The same high load capacities in all four main directions of loading
- ▶ High torque capacity and torsional moment compared to an X-array
- ▶ High degree of system rigidity and accuracy, optionally available with zero-clearance preload

Patented entry-zone geometry and optimized deflection

- ▶ Lowest frictional oscillation in connection with low friction force
- ▶ Improved travel accuracy

Integrated lubrication and sealing

- ▶ Relubricatable on all sides at 8 fittings
- ▶ Ball runner blocks are pre-lubricated at the factory
- ▶ Lubrication with grease, liquid grease and oil possible
- ▶ Integrated all-round sealing by means of end seals and longitudinal seals

Range of accessories

- ▶ Front seal, front lube unit and cover plate wiper



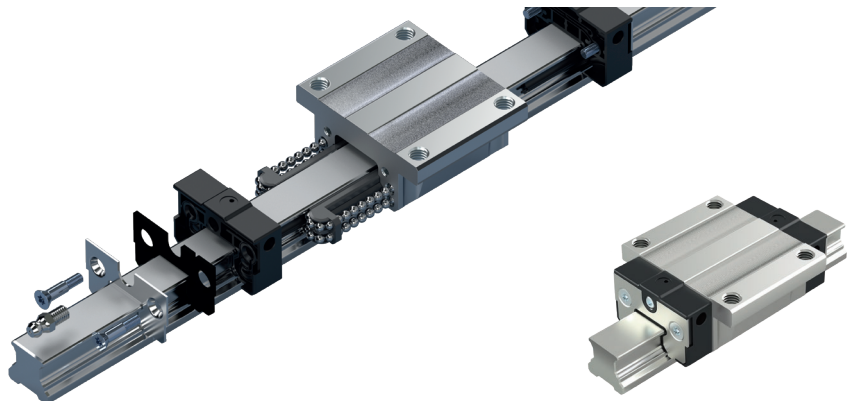

Technical data

- ▶ Load capacities:
 - C_{50} from 11,500 N to 99,800 N
 - C_{100} from 9,100 N to 79,200 N
 - C_0 from 11,700 N to 120,000 N
- ▶ Speeds up to 5 m/s
- ▶ Acceleration up to 500 m/s²

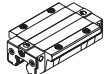

Ball rail system BSCL with steel ball runner block FNS (components and assembly)

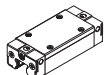

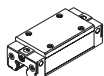
Ball runner block formats

		Application area	Load-bearing capacity	Special feature
FNS R205A		For normal rigidity requirements	High	For bolting from above and below
FLS R205B		For high rigidity requirements	Very high	For bolting from above and below
SNS R205C		For restricted space in the transverse direction	High	For mounting from above
SLS R205D		For restricted space in the transverse direction and high rigidity requirements	Very high	For mounting from above
SNH R205E		For restricted space in the transverse direction and high rigidity requirements	High	Higher rigidity than SNS
SLH R205F		For restricted space in the transverse direction and high rigidity requirements	Very high	Higher rigidity than SLS

Ball runner blocks with load capacities and load moments

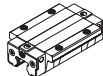
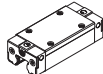
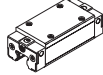
	Size	15	20	25	30	35	45	
FNS R205A		$C_{50}^{2)}$	11,500	18,400	27,500	39,300	54,100	78,100
		$C_{100}^{1)}$	9,100	14,600	21,800	31,200	42,900	62,000
		C_0	11,700	19,600	30,600	42,200	56,600	83,000
SNS R205C		$M_{t50}^{2)}$	98	190	340	590	970	1,790
		$M_{t100}^{1)}$	78	150	270	470	770	1,420
		M_{t0}	100	210	380	640	1,030	1,930
SNH R205E		$M_{L50}^{2)}$	79	160	280	450	720	1,320
		$M_{L100}^{1)}$	63	130	220	360	570	1,050
		M_{L0}	82	170	310	490	760	1,420
FLS R205B		$C_{50}^{2)}$	14,500	22,800	35,300	49,100	69,300	99,800
		$C_{100}^{1)}$	11,500	18,100	28,000	39,000	55,000	79,200
		C_0	16,800	27,100	44,200	58,800	81,600	120,000
SLS R205D		$M_{t50}^{2)}$	130	240	440	740	1,260	2,320
		$M_{t100}^{1)}$	100	190	350	590	1,000	1,840
		M_{t0}	150	290	550	890	1,480	2,780
SLH R205F		$M_{L50}^{2)}$	140	260	490	770	1,300	2,380
		$M_{L100}^{1)}$	110	210	390	610	1,030	1,890
		M_{L0}	160	320	620	920	1,530	2,860





1) Determination of the dynamic load capacities and load moments is based on a stroke travel of 100,000 m according to DIN ISO 14728-1.

2) Determination of the dynamic load capacities and load moments is based on a stroke travel of 50,000 m according to DIN ISO 14728-1.

See the chapter "General technical data and calculations" for the definition of the formula symbols

Ball runner block accessories

Connection elements are additionally available as options for the ball runner blocks.

	Application area
Cover plate wiper 	The cover plate wiper is an additional element for wiping off coarse grime or splinters or dealing with contamination that has been deposited on the ball guide rail.
Front seal 	Front seals provide effective protection for the ball runner block, preventing fine dirt or metal particles, as well as coolant or cutting fluid from working their way in. This means that the sealing effect is improved even more.
Seal kit 	When using cover plate wiper and front seal simultaneously, the seal kit is recommended.
Front lube unit 	When very frequent relubrication is required, front lube units allow travel distances of up to 10,000 km without relubrication under normal loads. The function is only assured where there is no exposure to liquids and little contamination. The maximum permissible operating temperature is 60°C.
Lubrication adapter 	For oil and grease lubrication from above for SNH and SLH ball runner blocks (high versions).

Ball guide rails

Ball guide rails BSCL can be supplied as factory lengths or ball guide rails cut-to-size (desired customer length).

	Description
Ball guide rail KSE-...-SNS; R2055 Standard ball guide rail made of steel, for bolting from above, with plastic caps	
Factory lengths	<p>Factory lengths are guide rails without end machining which are only available in four-meter sections. A factory length has an overall length of approx. 4,150 mm with a usable length (good length) of at least 3,600 mm in one piece of the respective accuracy class. The maximum good length is 4,150 mm. The good length is specified on the packaging and charged upon delivery. The plastic caps used to seal the fastening bores must be ordered separately.</p> <p>The factory lengths can be cut to the desired length by the user. You can obtain information in this respect from your sales partner and your local Bosch Rexroth sales companies.</p> <p>See also the „HowTo“ video on YouTube: https://www.youtube.com/watch?v=VbpsfKXSpG8</p>
Desired customer length	<p>Ball guide rails BSCL can be cut to length before delivery.</p> <p>The maximum lengths for a one-piece rail section can be found in the chapter "Ball guide rails".</p> <p>If longer rails are required, Bosch Rexroth will supply them as multi-piece ball guide rails.</p> <p>The plastic caps used to seal the fastening bores are part of the scope of delivery.</p>

Notes

General notes

- ▶ Combinations of different accuracy classes
Combining ball guide rails and ball runner blocks of different accuracy classes results in different tolerances for the dimensions H and A3. See "Accuracy classes and their tolerances."

Intended use

- ▶ The ball rail systems are linear guideways capable of absorbing forces from all transverse directions and moments about all axes. The ball rail system is intended exclusively for guiding and positioning tasks when installed in a machine.
- ▶ The product is intended exclusively for professional use and not for private use.
- ▶ Use for the intended purpose also includes the requirement that users must have read and understood the related documentation completely, in particular the "Safety instructions".

Misuse

Use of the product in any other way than as described under "Intended use" is considered to be misuse and is therefore not permitted. If unsuitable products are installed or used in safety-critical applications, this may lead to uncontrolled operating statuses in the application which can cause personal injury and/or damage to property.

The product may only be used in safety-critical applications if this use has been expressly specified and permitted in the product documentation.

Bosch Rexroth AG will not accept any liability for injury or damage caused by misuse of the product. The risks associated with any misuse of the product shall be borne by the user alone.

Misuse of the product includes:

- ▶ The transport of persons

General safety instructions

- ▶ The safety rules and regulations of the country in which the product is used must be observed.
- ▶ All current and applicable accident prevention and environmental regulations must be adhered to.
- ▶ The product may only be used when it is in technically perfect condition.
- ▶ The technical data and environmental conditions stated in the product documentation must be complied with.
- ▶ The product must not be put into service until it has been verified that the final product (for example a machine or system) into which the product has been installed complies with the country-specific requirements, safety regulations and standards for the application.
- ▶ Rexroth ball rail systems may not be used in zones with potentially explosive atmospheres as defined in ATEX directive 94/9/EC.
- ▶ Rexroth ball rail systems must never be altered or modified. The user may only perform the work described in the "Quick User Guide" or the "Instructions for profiled rail systems".
- ▶ The product is never allowed to be disassembled.
- ▶ At high travel speeds a certain amount of noise is caused by the product. If necessary, appropriate measures should be taken to protect hearing.
- ▶ The special safety requirements for specific sectors (e.g. crane construction, theaters, food technology) set forth in laws, directives and standards must be complied with.
- ▶ In all cases, the provisions of the following standard should be noted and followed. DIN 637, Safety regulations for dimensioning and operation of Profiled Rail Systems with recirculating rolling elements.

Directives and standards

Rexroth ball rail systems BHSP are suitable for dynamic linear applications requiring reliability and precision. The machine tool industry and other sectors must observe a series of standards and directives. These requirements can vary significantly worldwide. It is therefore essential to understand the legislation and standards that apply in each particular region.

DIN EN ISO 12100

This standard describes the safety of machinery – general principles for design, risk assessment and risk reduction. It gives a general overview and contains a guide to the major developments governing machines and their intended use.

Directive 2006/42/EC

The European Machinery Directive describes the basic safety and health requirements for the design and manufacture of machinery. The manufacturer of a machine or his authorized representative has a duty to ensure that a risk assessment has been performed in order to determine the health and safety requirements which have to be fulfilled for that machine. The machine must be designed and built taking into account the results of the risk assessment.

Directive 2001/95/EC

This directive covers general safety requirements for any product placed on the market and intended for consumers, or likely to be used by consumers under reasonably foreseeable conditions, including products that are made available to consumers in the context of service provision for use by them

Directive 1999/34/EC

This directive concerns the liability for defective products and applies to industrially manufactured movable objects, irrespective of whether or not they have been incorporated into another movable or immovable object.

REGULATION (EC) No. 1907/2006 (REACH)

This regulation relates to restrictions on the marketing and use of certain dangerous substances and preparations. "Substances" means chemical elements and their compounds as they occur in the natural state or as produced by industry. "Preparations" means mixtures or solutions composed of two or more substances.

Selection of a linear guide according to DIN 637

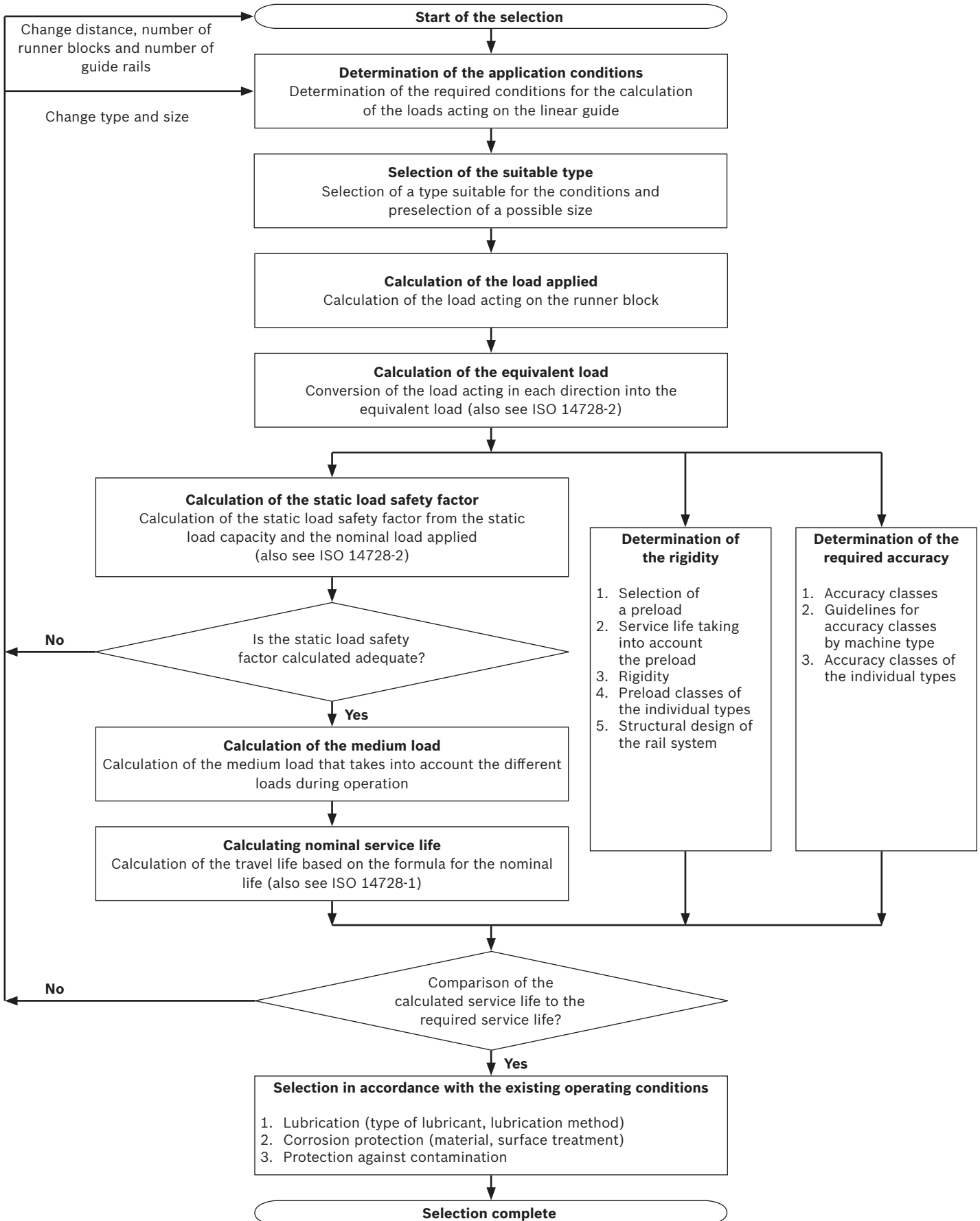

General technical data and calculations

General notes

The general technical data and calculations apply to all ball rail systems BSCL. This means to all ball runner blocks and ball guide rails. Specific technical data relating to the individual ball runner blocks and ball guide rails is given separately.

Load capacity definition based on 50 and 100 km

The definition of the load capacity is based on a nominal service life of 10^5 m = 100 km in the European region, whereas a load carrier definition based on a service life of 50 km has become prevalent in the Asian region. The conversion factor between both values is $C_{50} = 1.26 \times C_{100}$. Both values for the dynamic load capacities and load moments (which can be told by the index) are specified in this catalog. The following calculation chapter is based on the carrier load definition C_{100} .

Travel speed

$$v_{\max} : 5 \text{ m/s}$$

Acceleration

$$a_{\max} : 500 \text{ m/s}^2$$

If preload force F_{pr} is canceled, $a_{\max} = 50 \text{ m/s}^2$ applies
(If $F_{\text{comb}} > 2.8 \cdot F_{pr}$: $a_{\max} = 50 \text{ m/s}^2$)

Operating temperature range

$$t : -10 \text{ to } 80 \text{ } ^\circ\text{C}$$

Up to 100°C is permissible for a short time.

Friction

$$\mu : 0.002 - 0.003$$

Friction coefficient μ without seal friction

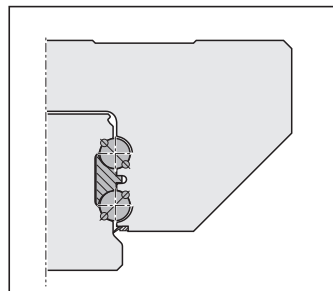

2-point contact

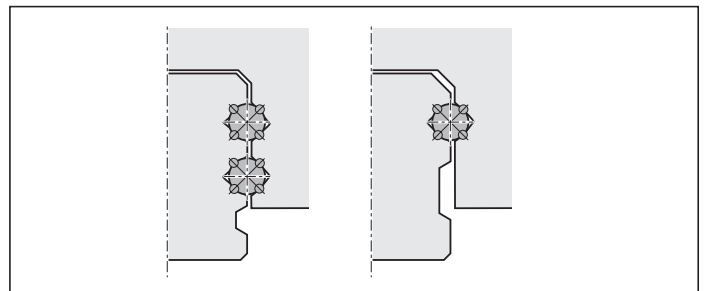

4-point contact

Due to the Rexroth design with four rows of balls, there are always **two points of contact** in all the directions of loading. This reduces the friction to a minimum.

Other ball rail systems with two or four rows of balls with **four points of contact** have multiple friction: the Gothic raceway profile causes higher friction due to the differential slip with lateral loading with a comparable preload without load (up to five times the friction coefficient depending on the raceway curvature and the load). This high friction leads correspondingly to greater heat.

Material specifications

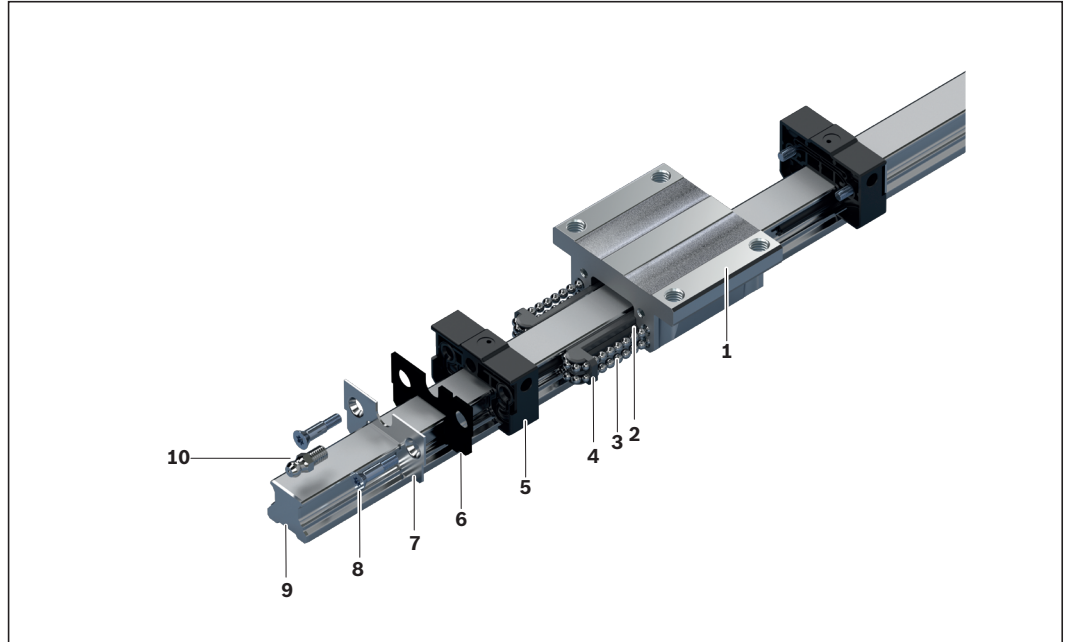

Item	Component	Material
1	Ball runner block body	Steel
2	Steel bearing plate	Anti-friction bearing steel
3	Balls	Anti-friction bearing steel
4	Frame	Plastic TEE-E
5	Ball guide	Plastic POM
6	Sealing plate	Elastomer NBR
7	Front panel	Corrosion resistant steel 1.4306
8	Countersunk screws	Galvanized carbon steel
9	Ball guide rail	Heat-treated steel
10	Lube nipple	Galvanized carbon steel *

* Not included in the delivery

General technical data and calculations

How to select a linear guide according to DIN 637 is described on page 10. The necessary calculations are explained in the following chapter. They are integrated in the "Linear Motion Designer" calculation program. You will find the link to the download in the chapter "Further information".

Forces and moments

In Rexroth ball rail systems the raceways are arranged at a pressure angle of 45°. This results in the same high load capacity of the entire system in all four main directions of loading.

The ball runner blocks may be subjected to both forces and load moments.

Forces in the four main directions of loading

- ▶ Tension F_z (positive z-direction)
- ▶ Pressure $-F_z$ (negative z-direction)
- ▶ Side load F_y (positive y-direction)
- ▶ Side load $-F_y$ (negative y-direction)

Moments

- ▶ Torsional moment M_x (around the y-axis)
- ▶ Longitudinal moment M_y (around the y-axis)
- ▶ Longitudinal moment M_z (around the z-axis)

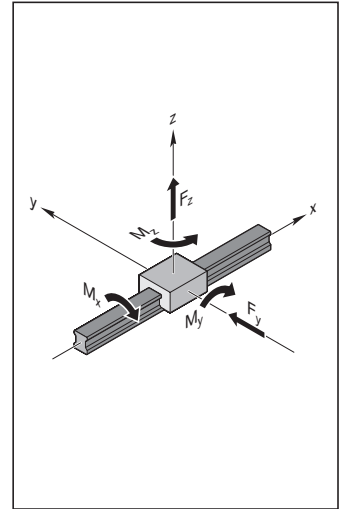

Definition of load capacities

Dynamic load capacity C_{100}

The radial load (whose extent and direction does not change) that a linear anti-friction bearing can theoretically absorb for a nominal life covering 10^5 m (according to DIN ISO 14728-1).

Note: The dynamic load capacities in the tables are above the DIN or ISO values. These values have been confirmed in tests.

Static load capacity C_0

Static load in the direction of loading that corresponds to a calculated load in the center of the contact point with the greatest load between the ball and raceway of 4200 MPa.

Note: With this stress at the contact point, permanent overall deformation of the ball and the track zone occurs that corresponds to about 0.0001 times the ball diameter (according to DIN ISO 14 728-1).

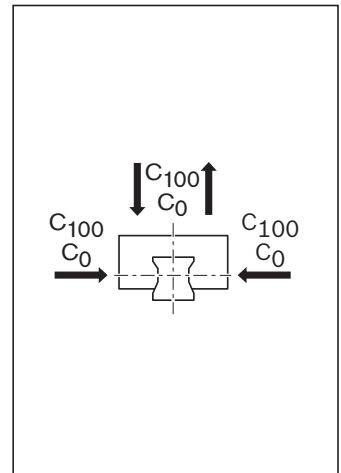

Definition of load moment capacities

Dynamic torsional moment load capacity M_{t100}

Comparative dynamic moment about the x-axis which causes a load equivalent to the dynamic load capacity C_{100} .

Static torsional moment load capacity M_{t0}

The comparable static moment around the x-axis that induces a load corresponding to the static load capacity C_0 .

Dynamic longitudinal moment load capacity M_{L100}

The dynamic comparable dynamic moment around the transverse axis y or the vertical axis z that induces a load corresponding to the dynamic load capacity C_{100} .

Static longitudinal moment load capacity M_{L0}

The static comparable dynamic moment around the transverse axis y or the vertical axis z that induces a load corresponding to the static load capacity C_0 .

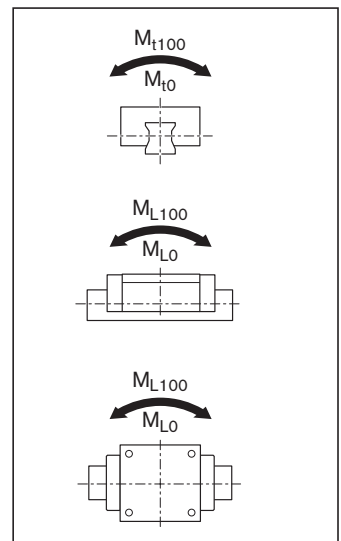

Definition and calculation of the nominal life

The calculated service life which an individual linear rolling bearing, or a group of apparently identical rolling element bearings operating under the same conditions, can attain with a 90% probability, with contemporary, commonly used materials and manufacturing quality under conventional operating conditions (as per ISO 14728-1).

Nominal life in meters

$$(1) \quad L = \left(\frac{C_{100}}{f_w \cdot F_m} \right)^3 \cdot 10^5 \text{ m}$$

Impact loads and vibrations cause additional loads on the contact point between ball and running track. It is difficult to accurately determine these conditions of use. However, these increase with increasing travel speed. The load factor f_w (see table) takes into account the effects of shock and vibration on the service life of the BSCL.

Conditions of use	Travel speed	Load factor f_w
No impact loads and vibrations	$v < 15 \text{ m/min}$	1.0 ... 1.2
Low impact loads and vibrations	$15 \text{ m/min} \leq v < 60 \text{ m/min}$	1.2 ... 1.5
Moderate impact loads and vibrations	$60 \text{ m/min} \leq v < 120 \text{ m/min}$	1.5 ... 2.0
High impact loads and vibrations	$v \geq 120 \text{ m/min}$	2.0 ... 3.5

Service life in operating hours with constant stroke and constant stroke repetition rate

$$(2) \quad L_h = \frac{L}{2 \cdot s \cdot n \cdot 60}$$

If the stroke length s and the stroke repetition rate n are constant over the total service life, you can use formula (2) to determine the service life in operating hours.

Nominal service life at variable travel speed

$$(3) \quad L_h = \frac{L}{60 \cdot v_m}$$

As an alternative, it is possible to use formula (3) to calculate the service life in operating hours using the average speed v_m . This average speed v_m is calculated with speeds that can be changed on a stepwise basis using discrete time steps q_{tn} of the individual load stages (4).

$$(4) \quad v_m = \frac{|v_1| \cdot q_{t1} + |v_2| \cdot q_{t2} + \dots + |v_n| \cdot q_{tn}}{100\%}$$

Modified life expectancy

$$L_{na} = a_1 \cdot \left(\frac{C_{100}}{f_w \cdot F_m} \right)^3 \cdot 10^5 \text{ m}$$

If a 90 percent requisite reliability is not enough, you must reduce the service life values by a factor of a_1 in accordance with the table below.

$$L_{ha} = \frac{L_{na}}{2 \cdot s \cdot n \cdot 60}$$

Requisite reliability (%)	L_{na}	Factor a_1
90	L_{10a}	1.00
95	L_{5a}	0.64
96	L_{4a}	0.55
97	L_{3a}	0.47
98	L_{2a}	0.37
99	L_{1a}	0.25

Notes

DIN ISO 14728-1 limits the validity of the formula (1) to dynamically equivalent loads $F_m < 0.5 C_{100}$. However, in our tests we verified that under ideal operating conditions this service life formula can be applied up to loads of $F_m = C_{100}$. Under some circumstances, with stroke lengths below $2 \cdot$ ball runner block length B_1 (see the dimension tables) a load capacity reduction may be required. Please consult us.

General technical data and calculations

Load on bearing for calculating the service life

Note

In general, both the static and dynamic load ratios should not be below the minimum value of 4.0. In the case of applications that place high demands on rigidity and/or the service life, a higher load ratio is required. The maximum admissible lateral forces, tensile forces and torques must be verified. The static load bearing safety S_0 in chapter "General technical data and calculations" must be observed. See the chapter "Instructions for mounting".

Dynamic load ratio

$$\frac{C_{100}}{F_{m \max}}$$

Static load ratio

$$\frac{C_0}{F_{0 \max}}$$

Combined equivalent bearing load

In the case of a combined vertical and horizontal external load, calculate the dynamically equivalent load F_{comb} according to formula (5).

Note

The structure of the ball rail system permits this simplified calculation.

Note

Reduce an external load that affects the ball runner block at any angle with the correct sign to F_y and F_z and insert the amounts into formula (5) or (6).

$$(5) \quad F_{\text{comb}} = |F_y| + |F_z|$$

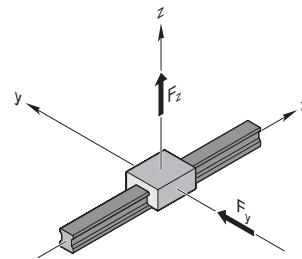

Combined equivalent load on bearing in conjunction with moments

Using formula (6), you can combine all the partial loads that occur in a load case into one single comparison load, i.e. the combined equivalent load on bearing.

Notes

Including moments as stated in formula (6) only applies to an individual ball guide rail with just one ball runner block. The formula is simpler for other combinations.

The forces and moments plotted in the coordinate system can also have an effect in the opposite direction. Reduce an external load that affects the ball runner block at any angle to F_y and F_z and insert the amounts into formula (6). The structural design of the ball runner blocks allows this simplified calculation.

$$(6) \quad F_{\text{comb}} = |F_y| + |F_z| + C_{100} \cdot \frac{|M_x|}{M_{t100}} + C_{100} \cdot \frac{|M_y|}{M_{L100}} + C_{100} \cdot \frac{|M_z|}{M_{L100}}$$

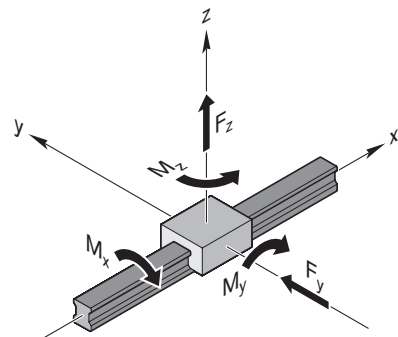

Considering the internal

Preload force F_{pr}

To increase the rigidity and precision of the guide system, it is advisable to use preloaded ball runner blocks (cf. "System preload selection criterion").

When using ball runner blocks of preload classes C2, it may be necessary to consider the internal preload force; this is because both rows of balls a and b are pre-tensioned against one another by a specific oversize at an internal preload force F_{pr} and deform by the amount δ_{pr} (see the diagram).

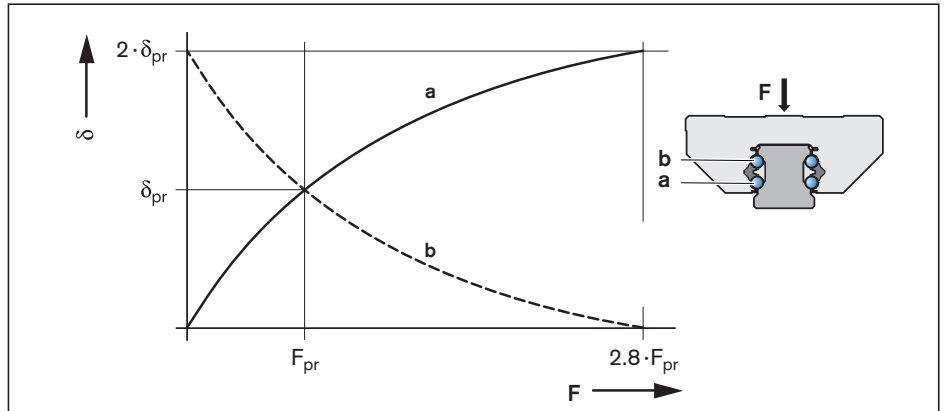

- a = Loaded (lower) row of balls
- b = Non-loaded (upper) row of balls
- δ = Deformation of rolling contact at F
- δ_{pr} = Deformation of rolling contact at F_{pr}
- F = Load on the ball runner block (N)
- F_{pr} = Internal preload force (N)

Effective equivalent load on bearing

From an external load amounting to 2.8 times the internal preload force F_{pr} onward, a row of balls becomes preload-free.

Note

Under highly dynamic load conditions, the combined equivalent bearing load should be $F_{comb} < 2.8 \cdot F_{pr}$ to prevent damage to anti-friction bearings due to slippage.

$$(7) \quad F_{eff} = F_{comb}$$

Case 1

$F_{comb} > 2.8 \cdot F_{pr}$
In this case, the internal preload force F_{pr} does not affect the service life.

$$(8) \quad F_{eff} = \left(\frac{F_{comb}}{2.8 \cdot F_{pr}} + 1 \right)^{3/2} \cdot F_{pr}$$

Case 2

$F_{comb} \leq 2.8 \cdot F_{pr}$
The preload force F_{pr} is included in the calculation of the effective equivalent load on bearing.

General technical data and calculations

Dynamically equivalent load on bearing

With different load stages, calculate the dynamically equivalent load on bearing according to formula (9).

$$(9) F_m = \sqrt[3]{(F_{\text{eff } 1})^3 \cdot \frac{q_{s1}}{100 \%} + (F_{\text{eff } 2})^3 \cdot \frac{q_{s2}}{100 \%} + \dots + (F_{\text{eff } n})^3 \cdot \frac{q_{sn}}{100 \%}}$$

Equivalent static load on bearing

With a combined vertical and horizontal external static load in conjunction with a static torsional or longitudinal moment, calculate the static equivalent load on bearing $F_{0 \text{ comb}}$ according to formula (10).

$$(10) F_{0 \text{ comb}} = |F_{0y}| + |F_{0z}| + C_0 \cdot \frac{|M_{0x}|}{M_{t0}} + C_0 \cdot \frac{|M_{0y}|}{M_{L0}} + C_0 \cdot \frac{|M_{0z}|}{M_{L0}}$$

Notes

The static equivalent load on bearing $F_{0 \text{ comb}}$ must not exceed the static load capacity C_0 . Formula (10) only applies when using a single ball guide rail.

Reduce an external load that affects the ball runner block at any angle to F_{0y} and F_{0z} and insert the amounts into formula (10).

Definitions and calculation for dynamic and static load ratios

Using the ratio of load capacity to load of the ball runner blocks, you can make a preselection of the guideway.

The dynamic loading ratio C_{100}/F_{max} and the static loading ratio $C_0/F_{0 \text{ max}}$ should be selected according to the application. The necessary load capacities are calculated from this. The load capacity overview yields the corresponding dimensions and format.

Recommended values for load ratios

The table below contains guideline values for the load ratios.

The values are offered merely as a rough guide reflecting typical customer requirements (e.g. service life, accuracy, rigidity) by sector and application.

$$\text{Dynamic ratio} = \frac{C_{100}}{F_{\text{max}}}$$

Machine type/sector	Application example	C_{100}/F_{max}
Machine tools	General	6 ... 9
	Turning	6 ... 7
	Milling	6 ... 7
	Grinding	9 ... 10
	Engraving	5
Rubber and plastics processing machinery	Injection molding	8
Woodworking and wood processing machines	Sawing, milling	5
Area of mounting/handling technology and industrial robots	Handling	5
Oil hydraulics and pneumatics	Lifting/lowering	6

Static load safety factor S_0

You must verify mathematically any structural design involving rolling contact with regard to the static load safety factor. The static load safety factor for a linear guide results from the following equation:

$$S_0 = \frac{C_0}{F_{0 \max}}$$

In this connection, $F_{0 \max}$ represents the maximum load amplitude that can occur, which can affect the linear guide. It does not matter whether this load is exerted only for a short period. It may represent the peak amplitude of an overall dynamic loading. For sizing, the data shown in the table applies.

Conditions of use	Static load safety factor S_0
Overhead hanging arrangements or applications with serious potential risks	≥ 12
High dynamic load when at standstill, contamination.	8 - 12
Normal sizing of machinery and plant without full knowledge of the load parameters or connection details.	5 - 8
Full knowledge of all the load data. Vibration-free operation is ensured.	3 - 5

Key to formulas

Formula	Unit	Designation
a	–	Loaded (lower) row of balls
a_1	–	Life expectancy factor
b	–	Non-loaded (upper) row of balls
C	N	Dynamic load capacity
C_0	N	Static load capacity
F_{\max}	N	Maximum dynamic load
$F_{0 \max}$	N	Maximum static load
F_{comb}	N	Combined equivalent bearing load
$F_{0 \text{comb}}$	N	Equivalent static load on bearing
F_{eff}	N	Effective equivalent load on bearing
$F_{\text{eff } 1-n}$	N	Uniform effective individual loads
F_m	N	Dynamically equivalent load on bearing
F_{pr}	N	Preload force
F_y	N	External load due to a resulting force in the y-direction
F_{0y}	N	External load due to a static force in the y-direction
F_z	N	External load due to a resulting force in the z-direction
F_{0z}	N	External load due to a static force in the z-direction
f_w	–	Load factor
M_t	Nm	Dynamic torsional moment load capacity ¹⁾
M_{t0}	Nm	Static torsional moment load capacity ¹⁾
M_L	Nm	Dynamic longitudinal moment load capacity ¹⁾
M_{L0}	Nm	Static longitudinal moment load capacity ¹⁾

Formula	Unit	Designation
M_x	Nm	Load due to the resultant moment around the x-axis
M_{0x}	Nm	Load due to the static moment around the x-axis
M_y	Nm	Load due to the resultant moment around the y-axis
M_{0y}	Nm	Load due to the static moment around the y-axis
M_z	Nm	Load due to the resultant moment around the z-axis
M_{0z}	Nm	Load due to the static moment around the z-axis
L	m	Nominal life (travel range)
L_h	h	Nominal life (time)
L_{na}	m	Modified life expectancy (travel range)
L_{ha}	h	Modified life expectancy (time)
n	min ⁻¹	Stroke repetition rate (full cycles)
$q_{t1} \dots q_{tn}$	%	Discrete time steps for $v_1 \dots v_n$ of phases 1 ... n
s	m	Stroke length
S_0	–	Static load safety factor
v_m	m/min	Average linear speed
$v_1 \dots v_n$	m/min	Travel speeds of phases 1 ... n
v	m/min	Travel speed
δ	–	Deformation of rolling contact at F
δ_{pr}	–	Deformation of rolling contact at F_{pr}

Refer to the table for the values

System preload

Definition of preload

Ball runner blocks can be preloaded to increase rigidity. The internal preload forces that occur in this connection must be considered in the life expectancy calculation. You can choose the preload class to match the area of application. Refer to the table for preload force F_{pr} . Rigidity diagrams are available on request.

To prevent reductions to the service life, the preload should not exceed 1/3 of the load on bearing F.

In general, the rigidity of the ball runner block rises with increasing preload. If vibrations occur, choose the correspondingly high preload (preload class C2).

Code	Preload	Application area
C0	Without preload (clearance)	For particularly smooth-running guide systems with the lowest possible friction for applications with large installation tolerances. Clearance versions are available only in accuracy classes N and H.
C1	Moderate preload	For precise guide systems with low external loads and high demands on overall rigidity.
C2	Medium preload	For precise guide systems with both high external loading and high demands on overall rigidity; also recommended for single-rail systems and high accelerations. Above average moment loads can be absorbed without significant elastic deflection. Further improved overall rigidity with only medium moment loads.

Preload force F_{pr} (N) of the ball runner blocks

Material numbers	Format	Preload class	Size					
			15	20	25	30	35	45
R205A R205C R205E	FNS SNS SNH	C1	150	230	350	500	690	990
		C2	590	950	1,420	2,030	2,790	4,030
R205B R205D R205F	FLS SLS SLH	C1	180	290	450	620	880	1,270
		C2	750	1,180	1,820	2,540	3,580	5,150

Example

- ▶ Area of application: Precise guide systems with low external load and high overall rigidity requirements. This results in preload class C1.
- ▶ Selected ball runner block: FNS R205A 314 20
- ▶ The selected ball runner block yields a preload force of $F_{pr} = 690$ N according to the table.

Accuracy classes

Accuracy classes and their tolerances

BSCL ball rail systems are available in three accuracy classes.

For details of the available ball runner blocks and ball guide rails, see the "Material numbers" tables.

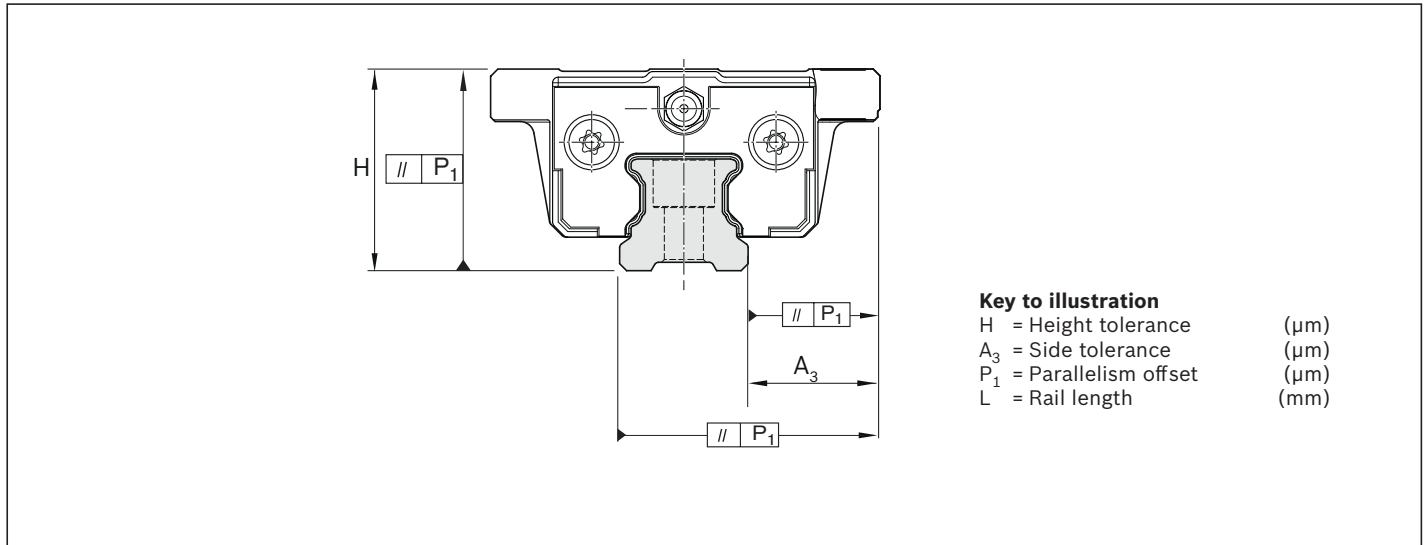

Precision manufacturing process makes interchangeability easy

Rexroth manufactures its ball guide rails and ball runner blocks with such high precision, especially in the ball raceway zone, that each individual component element is fully interchangeable. For example, a ball runner block can be used without problems on various ball guide rails of the same size. Similarly, different ball runner blocks can also be used on one and the same ball guide rail.

Steel ball rail systems

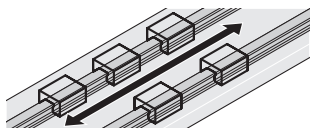
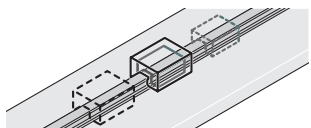
<p>Measured in middle of runner block</p>	 <p>For any ball runner block/rail combination at any position along the entire rail length</p>	 <p>For different ball runner blocks at same position on rail</p>
--	--	--

Accuracy classes	Tolerances of the dimensions (µm)		Max. differences of dimensions H and A ₃ on one rail (µm)	
	H	A ₃	ΔH, ΔA ₃	
N	±100	±40		30
H	±40	±20		15
P	±20	±10		7

Guide systems with parallel rails

When choosing the preload class, also pay attention to the permissible parallelism offset of the rails ("Accuracy class selection criterion").

When specifying ball rail systems of accuracy class N, we recommend preload class C0 or C1 to avoid distortive stress due to the tolerances.

Parallelism offset P_1 of the ball rail system in operation
Measured at middle of runner block

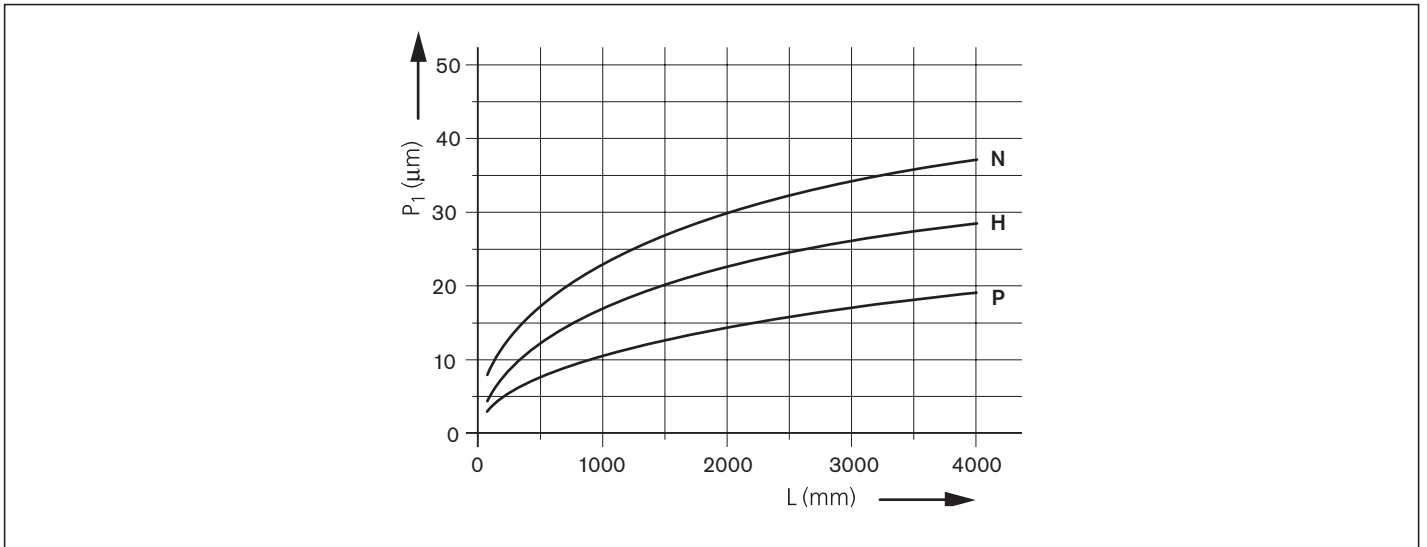

Tolerances for combination of accuracy classes

Ball runner blocks		Ball guide rails		
		N (µm)	H (µm)	P (µm)
N	Tolerance of dimension H (µm)	±100	±48	±32
	Tolerance of dimension A_3 (µm)	±40	±28	±22
	Max. diff. dimensions H and A_3 on one rail (µm)	30	30	30
H	Tolerance of dimension H (µm)	±92	±40	±24
	Tolerance of dimension A_3 (µm)	±32	±20	±14
	Max. diff. dimensions H and A_3 on one rail (µm)	15	15	15
P	Tolerance of dimension H (µm)	±88	±36	±20
	Tolerance of dimension A_3 (µm)	±28	±16	±10
	Max. diff. dimensions H and A_3 on one rail (µm)	7	7	7

Recommendations for combining accuracy classes

Recommended with **relatively large ball runner block distances** and long strokes:

Ball guide rail in higher accuracy class than ball runner blocks.

Recommended with **small ball runner block distances** and short strokes:

Ball runner blocks in higher accuracy class than ball guide rail.

Ball runner block ordering example

Ordering ball runner blocks

The material number is composed of the code numbers for the individual options. Each option is coded in a material number digit.

Ordering example

- ▶ Ball runner blocks FNS
- ▶ Size 30
- ▶ Preload class C1
- ▶ Accuracy class H
- ▶ With standard seal
- ▶ Pre-lubricated

Material number: R205A 713 20

BSCL ball runner block		R205	A	7	1	3	20
Format	A = FNS (flanged, normal, standard height) B = FLS (flanged, long, standard height) C = SNS (slimline, normal, standard height) D = SLS (slimline, long, standard height) E = SNH (slimline, normal, high) F = SLH (slimline, long, high)						
Size	1 = size 15 8 = size 20 2 = size 25 7 = size 30 3 = size 35 4 = size 45						
Preload	9 = preload class C0 1 = preload class C1 2 = preload class C2						
Accuracy	4 = accuracy class N 3 = accuracy class H 2 = accuracy class P						
Lubrication	20 = standard seal, pre-lubricated and preserved						

BSCL ball runner block type key

BALL RUNNER BLOCK CS	KWE	-	0	3	0	-	F	N	S	-	C	1	-	H	-	1	
			1				2				3			4			5

1 Size

Characteristic	Designation
015	size 15
020	Size 20
025	Size 25
030	Size 30
035	Size 35
045	Size 45

2 Format

Characteristic	Designation
FNS	Flanged, normal, standard height
FLS	Flanged, long, standard height
SNS	Slimline, normal, standard height
SLS	Slimline, long, standard height
SNH	Slimline, normal, high
SLH	Slimline, long, high

3 Preload class

Characteristic	Designation
C0	Without preload
C1	Preload class C1 (moderate preload)
C2	Preload class C2 (medium preload)

4 Accuracy class

Characteristic	Designation
N	Normal
H	High
P	Precision

5 Lubrication (runner block)

Characteristic	Designation
1	Pre-lubricated, preserved

FNS – flanged, normal, standard height – R205A

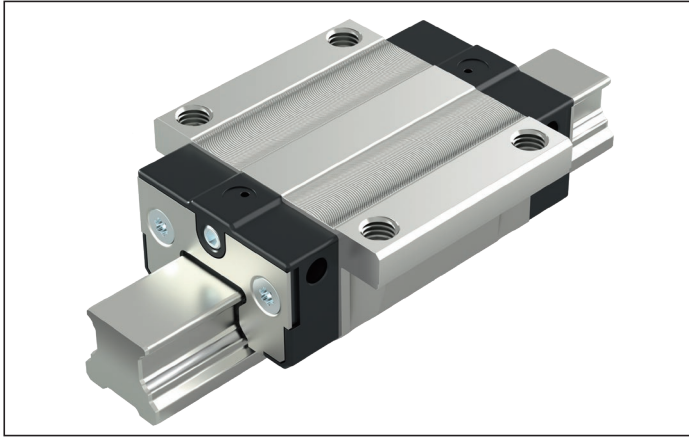
**Dynamic characteristics**

Travel speed: $v_{\max} = 5 \text{ m/s}$
 Acceleration: $a_{\max} = 500 \text{ m/s}^2$
 (If $F_{\text{comb}} > 2.8 \cdot F_{\text{pr}}$: $a_{\max} = 50 \text{ m/s}^2$)

Note

Can be used on all BSCL ball guide rails KSE-...-SNS

Options and material numbers

Size	Ball runner blocks with size	Preload class			Accuracy class			Standard seal pre-lubricated
		C0	C1	C2	N	H	P	
15	R205A 1	9			4	3	–	20
			1		4	3	2	20
				2	–	3	2	20
20	R205A 8	9			4	3	–	20
			1		4	3	2	20
				2	–	3	2	20
25	R205A 2	9			4	3	–	20
			1		4	3	2	20
				2	–	3	2	20
30	R205A 7	9			4	3	–	20
			1		4	3	2	20
				2	–	3	2	20
35	R205A 3	9			4	3	–	20
			1		4	3	2	20
				2	–	3	2	20
45	R205A 4	9			4	3	–	20
			1		4	3	2	20
				2	–	3	2	20

Size	Load capacitys (N)			Load moments (Nm)					
	 $C_{50}^{1)}$	$C_{100}^{2)}$	C_0	$M_{t50}^{1)}$	$M_{t100}^{2)}$	M_{t0}	$M_{L50}^{1)}$	$M_{L100}^{2)}$	M_{L0}
15	11,500	9,100	11,700	98	78	100	79	63	82
20	18,400	14,600	19,600	190	150	210	160	130	170
25	27,500	21,800	30,600	340	270	380	280	220	310
30	39,300	31,200	42,200	590	470	640	450	360	490
35	54,100	42,900	56,600	970	770	1,030	720	570	760
45	78,100	62,000	83,000	1,790	1,420	1,930	1,320	1,050	1,420

1) Dynamic load capacity and load moments based on a travel life of 50,000 m.

2) Dynamic load capacity and load moments based on a travel life of 100,000 m.

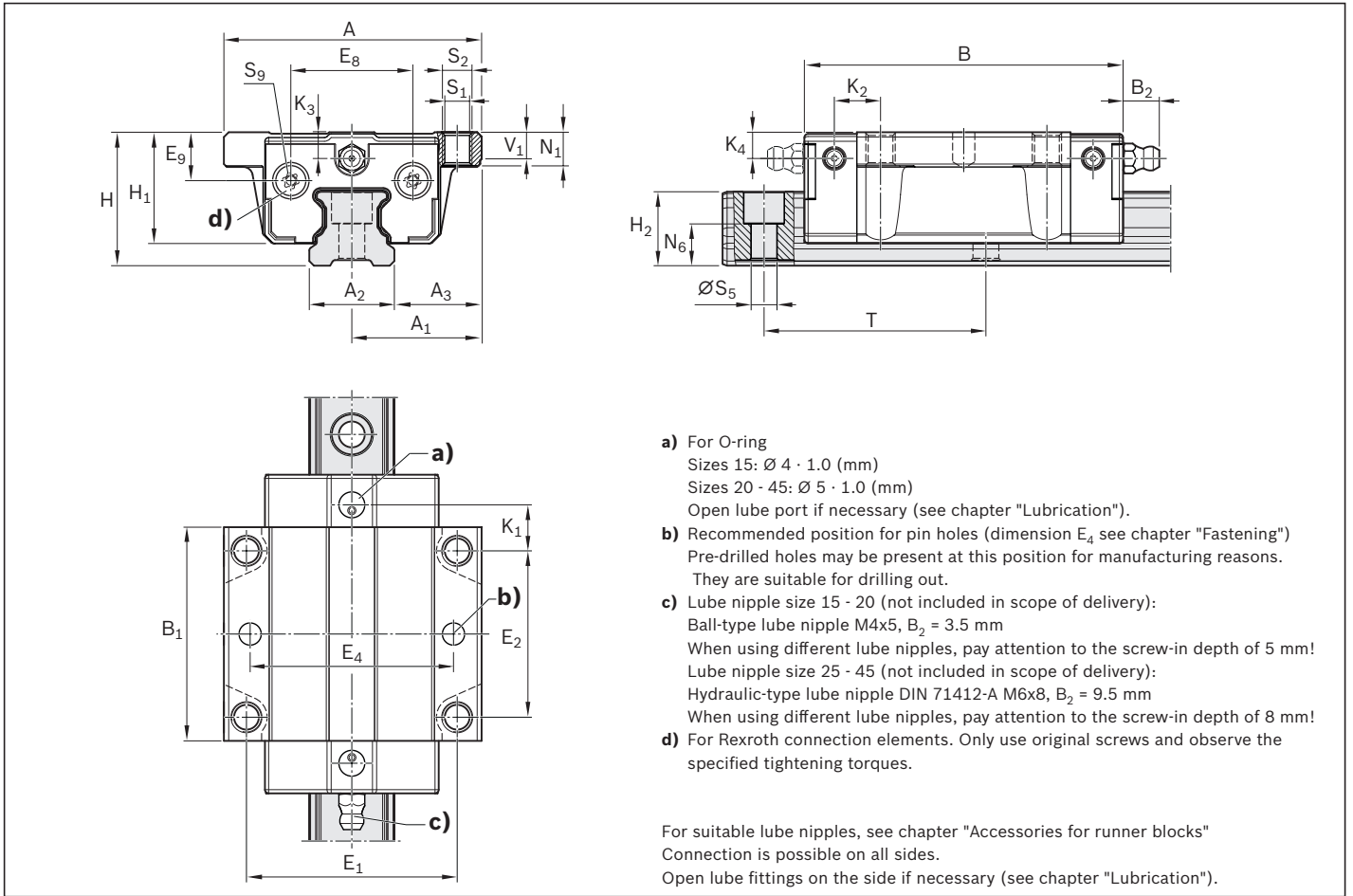

Size	Dimensions (mm)												
	A	A ₁	A ₂	A ₃	B ^{+0.5}	B ₁	E ₁	E ₂	E ₈	E ₉	H	H ₁	H ₂
15	47.0	23.50	15.0	16.00	58.2	39.2	38.0	30.0	20.5	7.8	24.0	19.90	14.10
20	63.0	31.50	20.0	21.50	75.0	49.6	53.0	40.0	29.0	10.15	30.0	25.30	17.00
25	70.0	35.00	23.0	23.50	86.2	57.8	57.0	45.0	33.0	13.0	36.0	30.00	20.00
30	90.0	45.00	28.0	31.00	97.7	67.4	72.0	52.0	42.0	14.25	42.0	35.35	23.00
35	100.0	50.00	34.0	33.00	110.5	77.0	82.0	62.0	50.0	15.7	48.0	40.40	26.50
45	120.0	60.00	45.0	37.50	137.5	97.0	100.0	80.0	61.0	19.5	60.0	50.30	33.00

Size	Dimensions (mm)												Mass (kg)	
	K ₁	K ₂	K ₃	K ₄	N ₁	N ₆ ^{±0.5}	S ₁	S ₂	S ₅	S ₉	T	V ₁	m	
15	8.0	9.1	3.80	3.80	5.2	8.6	4.3	M5	4.5	M2.5x5	60.0	5.0	0.18	
20	11.8	11.8	5.65	5.65	7.7	10.0	5.3	M6	6.0	M2.5x6	60.0	6.0	0.41	
25	12.5	12.5	7.00	7.00	9.0	11.3	6.7	M8	7.0	M3x6.5	60.0	7.5	0.60	
30	14.0	14.7	7.25	7.25	11.0	12.0	8.5	M10	9.0	M3x6.5	80.0	7.0	1.01	
35	14.5	16.2	7.00	7.00	12.0	15.5	8.5	M10	9.0	M3x6.5	80.0	8.0	1.51	
45	17.3	19.5	10.50	10.50	15.0	17.0	10.4	M12	14.0	M3x6.5	105.0	10.0	2.92	

FLS – flanged, long, standard height – R205B

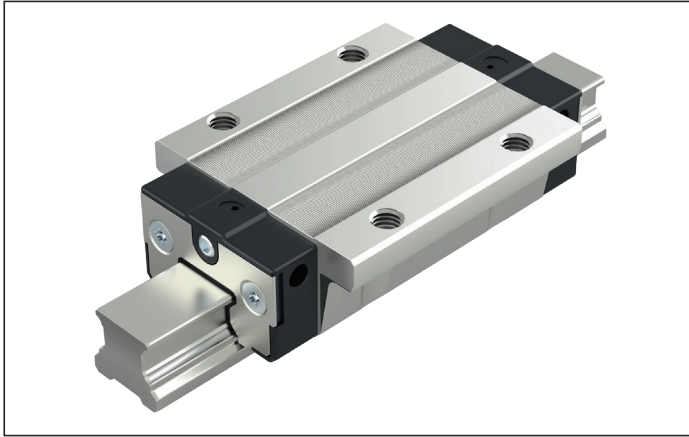
**Dynamic characteristics**Travel speed: $v_{\max} = 5 \text{ m/s}$ Acceleration: $a_{\max} = 500 \text{ m/s}^2$ (If $F_{\text{comb}} > 2.8 \cdot F_{\text{pr}}$: $a_{\max} = 50 \text{ m/s}^2$)**Note**

Can be used on all BSCL ball guide rails KSE-...-SNS

Options and material numbers

Size	Ball runner blocks with size	Preload class			Accuracy class			Standard seal pre-lubricated
		C0	C1	C2	N	H	P	
15	R205B 1	9			4	3	–	20
			1		4	3	2	20
				2	–	3	2	20
20	R205B 8	9			4	3	–	20
			1		4	3	2	20
				2	–	3	2	20
25	R205B 2	9			4	3	–	20
			1		4	3	2	20
				2	–	3	2	20
30	R205B 7	9			4	3	–	20
			1		4	3	2	20
				2	–	3	2	20
35	R205B 3	9			4	3	–	20
			1		4	3	2	20
				2	–	3	2	20
45	R205B 4	9			4	3	–	20
			1		4	3	2	20
				2	–	3	2	20

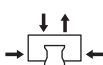
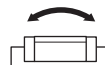
Size	Load capacitys (N)			Load moments (Nm)					
	 $C_{50}^{1)}$	$C_{100}^{2)}$	C_0	$M_{t50}^{1)}$	$M_{t100}^{2)}$	M_{t0}	 $M_{L50}^{1)}$	$M_{L100}^{2)}$	M_{L0}
15	14,500	11,500	16,800	130	100	150	140	110	160
20	22,800	18,100	27,100	240	190	290	260	210	320
25	35,300	28,000	44,200	440	350	550	490	390	620
30	49,100	39,000	58,800	740	590	890	770	610	920
35	69,300	55,000	81,600	1,260	1,000	1,480	1,300	1,030	1,530
45	99,800	79,200	120,000	2,320	1,840	2,780	2,380	1,890	2,860

1) Dynamic load capacity and load moments based on a travel life of 50,000 m.

2) Dynamic load capacity and load moments based on a travel life of 100,000 m.

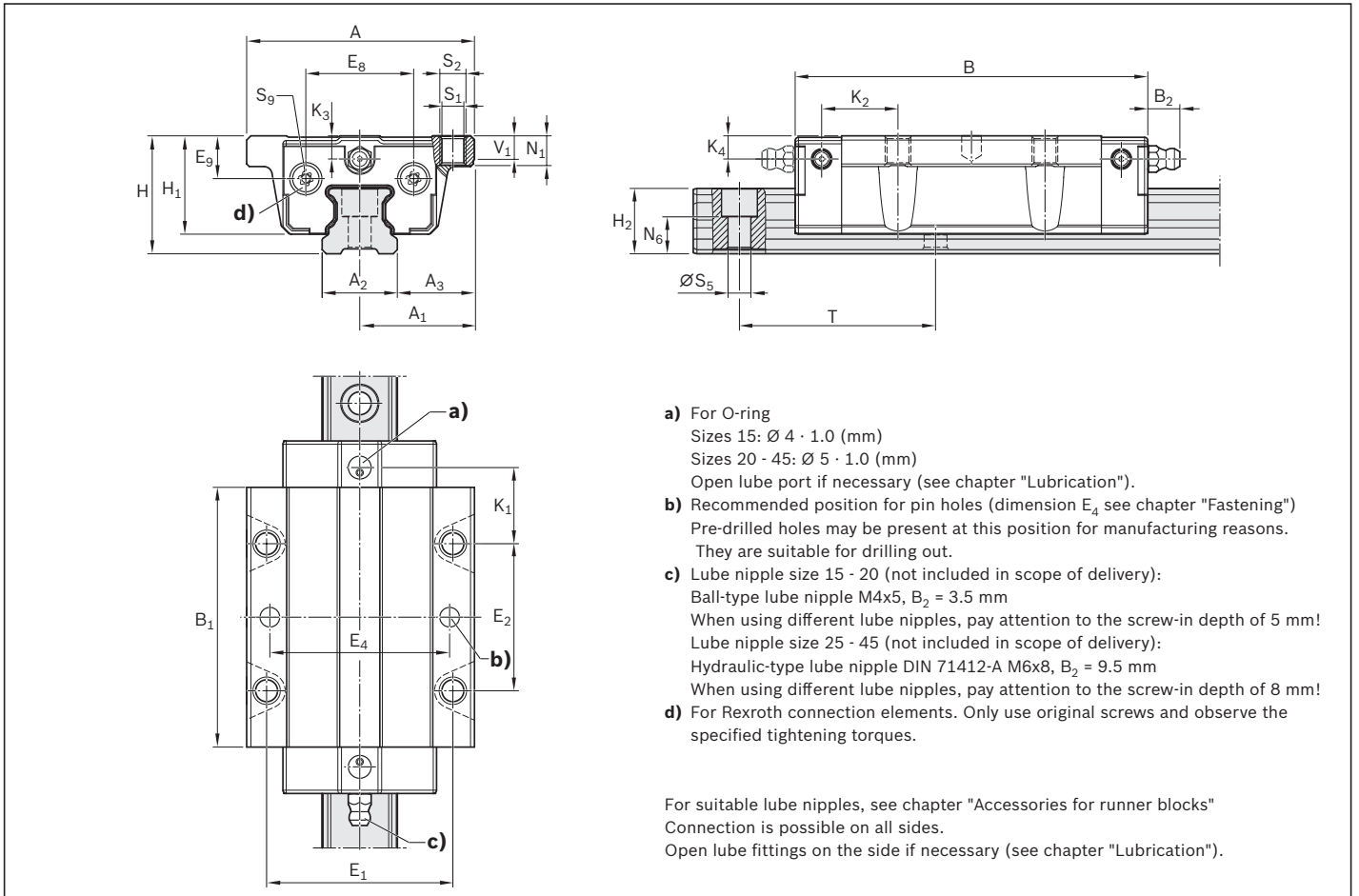

Size	Dimensions (mm)												
	A	A ₁	A ₂	A ₃	B ^{+0.5}	B ₁	E ₁	E ₂	E ₈	E ₉	H	H ₁	H ₂
15	47.0	23.50	15.0	16.00	72.6	53.6	38.0	30.0	20.5	7.80	24.0	19.90	14.10
20	63.0	31.50	20.0	21.50	91.0	65.6	53.0	40.0	29.0	10.15	30.0	25.30	17.00
25	70.0	35.00	23.0	23.50	107.9	79.5	57.0	45.0	33.0	13.00	36.0	30.00	20.00
30	90.0	45.00	28.0	31.00	119.7	89.4	72.0	52.0	42.0	14.25	42.0	35.35	23.00
35	100.0	50.00	34.0	33.00	139.0	105.5	82.0	62.0	50.0	15.70	48.0	40.40	26.50
45	120.0	60.00	45.0	37.50	174.0	133.5	100.0	80.0	61.0	19.50	60.0	50.30	33.00

Size	Dimensions (mm)												Mass (kg)	
	K ₁	K ₂	K ₃	K ₄	N ₁	N ₆ ^{±0.5}	S ₁	S ₂	S ₅	S ₉	T	V ₁	m	
15	15.20	16.30	3.80	3.80	5.2	8.55	4.3	M5	4.4	M2.5x5	60.0	5.0	0.25	
20	19.80	19.80	5.65	5.65	7.7	10.0	5.3	M6	6.0	M2.5x6	60.0	6.0	0.53	
25	23.30	23.35	7.00	7.00	9.0	11.3	6.7	M8	7.0	M3x6.5	60.0	7.5	0.80	
30	25.00	25.70	7.25	7.25	11.0	12.0	8.5	M10	9.0	M3x6.5	80.0	7.0	1.31	
35	28.75	30.40	7.00	7.00	12.0	15.5	8.5	M10	9.0	M3x6.5	80.0	8.0	2.02	
45	35.5	37.75	10.50	10.50	15.0	17.0	10.4	M12	14.0	M3x6.5	105.0	10.0	3.93	

SNS – slimline, normal, standard height – R205C

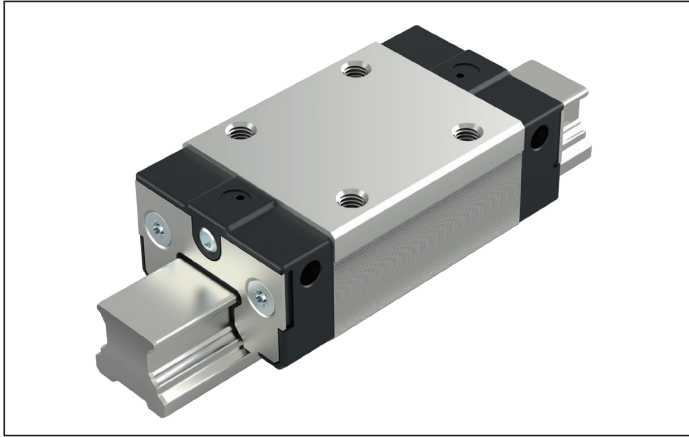
**Dynamic characteristics**Travel speed: $v_{\max} = 5 \text{ m/s}$ Acceleration: $a_{\max} = 500 \text{ m/s}^2$ (If $F_{\text{comb}} > 2.8 \cdot F_{\text{pr}}$: $a_{\max} = 50 \text{ m/s}^2$)**Note**

Can be used on all BSCL ball guide rails KSE-...-SNS

Options and material numbers

Size	Ball runner blocks with size	Preload class			Accuracy class			Standard seal
		C0	C1	C2	N	H	P	pre-lubricated
15	R205C 1	9			4	3	–	20
			1		4	3	2	20
				2	–	3	2	20
20	R205C 8	9			4	3	–	20
			1		4	3	2	20
				2	–	3	2	20
25	R205C 2	9			4	3	–	20
			1		4	3	2	20
				2	–	3	2	20
30	R205C 7	9			4	3	–	20
			1		4	3	2	20
				2	–	3	2	20
35	R205C 3	9			4	3	–	20
			1		4	3	2	20
				2	–	3	2	20
45	R205C 4	9			4	3	–	20
			1		4	3	2	20
				2	–	3	2	20

Size	Load capacitys (N)			Load moments (Nm)					
	$C_{50}^{1)}$	$C_{100}^{2)}$	C_0	$M_{t50}^{1)}$	$M_{t100}^{2)}$	M_{t0}	$M_{L50}^{1)}$	$M_{L100}^{2)}$	M_{L0}
15	11,500	9,100	11,700	98	78	100	79	63	82
20	18,400	14,600	19,600	190	150	210	160	130	170
25	27,500	21,800	30,600	340	270	380	280	220	310
30	39,300	31,200	42,200	590	470	640	450	360	490
35	54,100	42,900	56,600	970	770	1,030	720	570	760
45	78,100	62,000	83,000	1,790	1,420	1,930	1,320	1,050	1,420

1) Dynamic load capacity and load moments based on a travel life of 50,000 m.

2) Dynamic load capacity and load moments based on a travel life of 100,000 m.

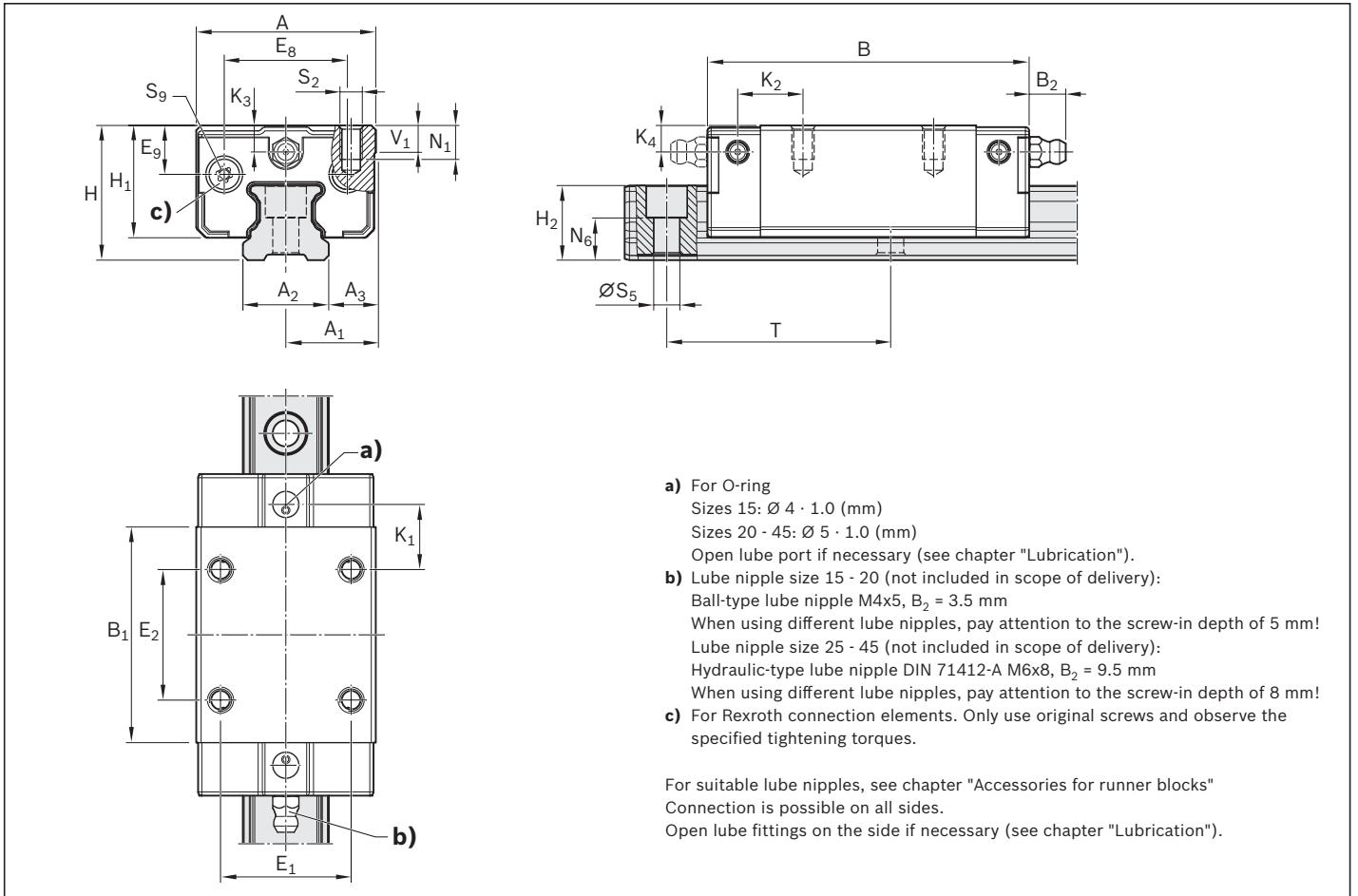

Size	Dimensions (mm)												
	A	A ₁	A ₂	A ₃	B ^{+0.5}	B ₁	E ₁	E ₂	E ₈	E ₉	H	H ₁	H ₂
15	34.0	17.0	15.0	9.50	58.2	39.2	26.0	26.0	20.5	7.80	24.0	19.90	14.10
20	44.0	22.0	20.0	12.00	75.0	49.6	32.0	36.0	29.0	10.15	30.0	25.30	17.00
25	48.0	24.0	23.0	12.50	86.2	57.8	35.0	35.0	33.0	13.00	36.0	30.00	20.00
30	60.0	30.0	28.0	16.00	97.7	67.4	40.0	40.0	42.0	14.25	42.0	35.35	23.00
35	70.0	35.0	34.0	18.00	110.5	77.0	50.0	50.0	50.0	15.70	48.0	40.40	26.50
45	86.0	43.0	45.0	20.50	137.5	97.0	60.0	60.0	61.0	19.50	60.0	50.30	33.00

Size	Dimensions (mm)											Mass (kg)	
	K ₁	K ₂	K ₃	K ₄	N ₁	N ₆ ^{+0.5}	S ₂	S ₅	S ₉	T	V ₁	m	
15	10.0	11.10	3.80	3.80	6.0	8.55	M4	4.4	M2.5x5	60.0	5.4	0.16	
20	13.8	13.80	5.65	5.65	7.5	10.0	M5	6.0	M2.5x6	60.0	6.0	0.35	
25	17.45	17.50	7.00	7.00	9.0	11.3	M6	7.0	M3x6.5	60.0	7.5	0.50	
30	20.0	20.70	7.25	7.25	12.0	12.0	M8	9.0	M3x6.5	80.0	7.0	0.85	
35	20.5	22.15	7.00	7.00	13.0	15.5	M8	9.0	M3x6.5	80.0	8.0	1.27	
45	27.3	29.50	10.50	10.50	18.0	17.0	M10	14.0	M3x6.5	105.0	10.0	2.40	

SLS – slimline, long, standard height – R205D

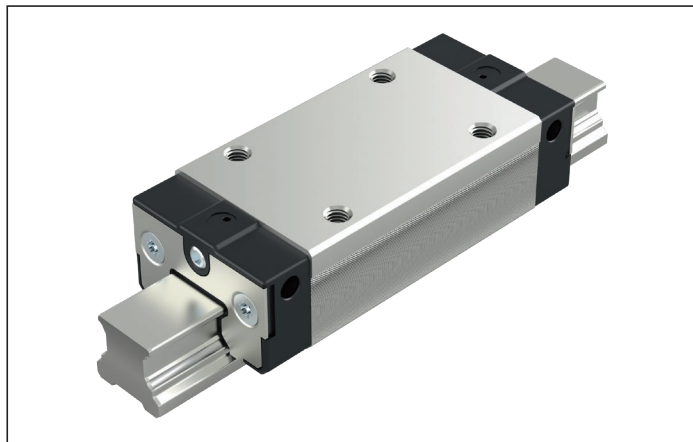
**Dynamic characteristics**

Travel speed: $v_{\max} = 5 \text{ m/s}$
 Acceleration: $a_{\max} = 500 \text{ m/s}^2$
 (If $F_{\text{comb}} > 2.8 \cdot F_{\text{pr}}$: $a_{\max} = 50 \text{ m/s}^2$)

Note

Can be used on all BSCL ball guide rails KSE-...-SNS

Options and material numbers

Size	Ball runner blocks with size	Preload class			Accuracy class			Standard seal pre-lubricated
		C0	C1	C2	N	H	P	
15	R205D 1	9			4	3	–	20
			1		4	3	2	20
				2	–	3	2	20
20	R205D 8	9			4	3	–	20
			1		4	3	2	20
				2	–	3	2	20
25	R205D 2	9			4	3	–	20
			1		4	3	2	20
				2	–	3	2	20
30	R205D 7	9			4	3	–	20
			1		4	3	2	20
				2	–	3	2	20
35	R205D 3	9			4	3	–	20
			1		4	3	2	20
				2	–	3	2	20
45	R205D 4	9			4	3	–	20
			1		4	3	2	20
				2	–	3	2	20

Size	Load capacitys (N)			Load moments (Nm)					
	$C_{50}^{1)}$	$C_{100}^{2)}$	C_0	$M_{t50}^{1)}$	$M_{t100}^{2)}$	M_{t0}	$M_{L50}^{1)}$	$M_{L100}^{2)}$	M_{L0}
15	14,500	11,500	16,800	130	100	150	140	110	160
20	22,800	18,100	27,100	240	190	290	260	210	320
25	35,300	28,000	44,200	440	350	550	490	390	620
30	49,100	39,000	58,800	740	590	890	770	610	920
35	69,300	55,000	81,600	1,260	1,000	1,480	1,300	1,030	1,530
45	99,800	79,200	120,000	2,320	1,840	2,780	2,380	1,890	2,860

1) Dynamic load capacity and load moments based on a travel life of 50,000 m.

2) Dynamic load capacity and load moments based on a travel life of 100,000 m.

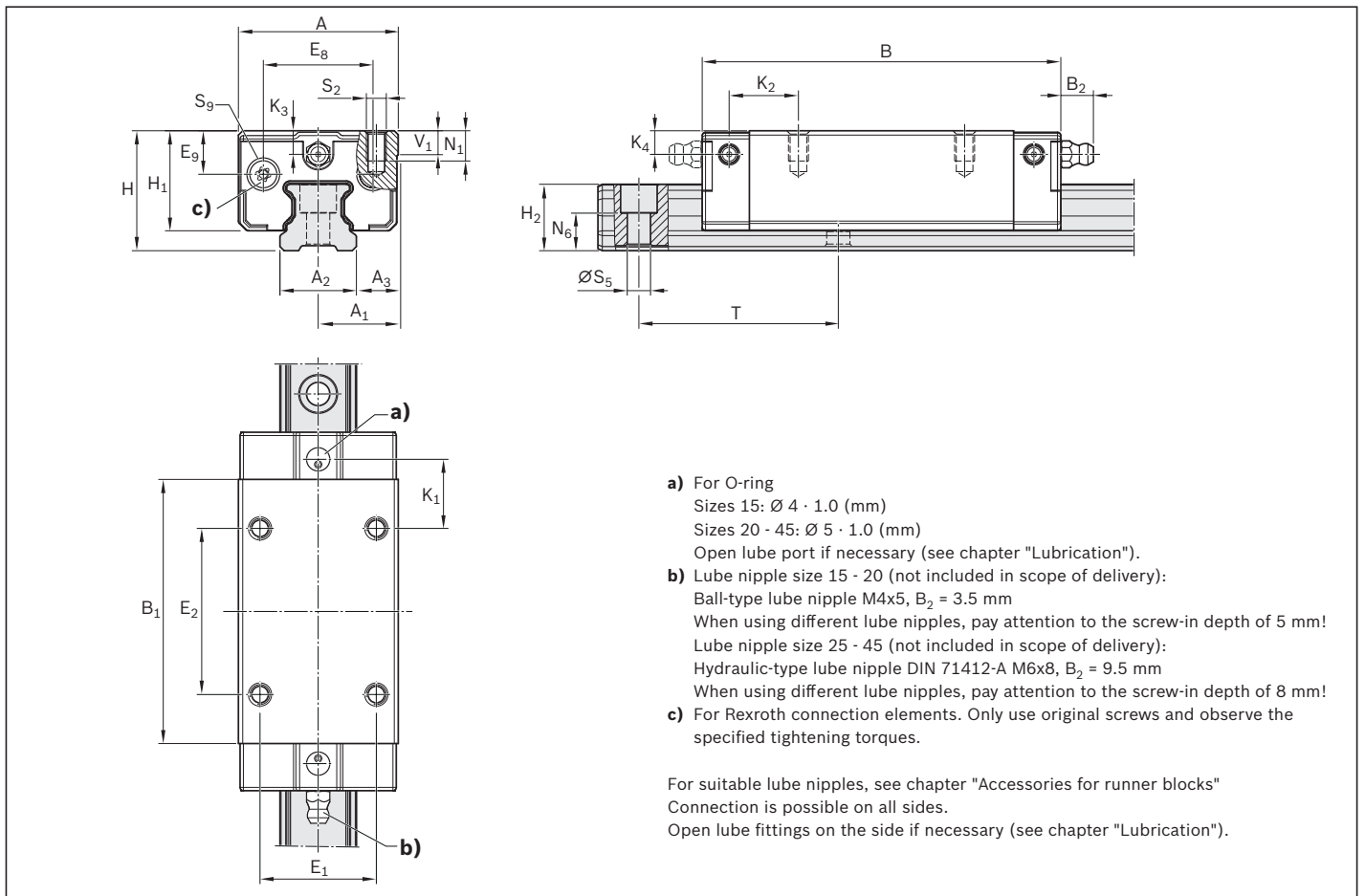

Size	Dimensions (mm)												
	A	A ₁	A ₂	A ₃	B ^{+0.5}	B ₁	E ₁	E ₂	E ₈	E ₉	H	H ₁	H ₂
15	34.0	17.0	15.0	9.50	72.6	53.6	26.0	26.0	20.5	7.8	24.0	19.90	14.10
20	44.0	22.0	20.0	12.00	91.0	65.6	32.0	50.0	29.0	10.15	30.0	25.30	17.00
25	48.0	24.0	23.0	12.50	107.9	79.5	35.0	50.0	33.0	13.0	36.0	30.00	20.00
30	60.0	30.0	28.0	16.00	119.7	89.4	40.0	60.0	42.0	14.25	42.0	35.35	23.00
35	70.0	35.0	34.0	18.00	139.0	105.5	50.0	72.0	50.0	15.7	48.0	40.40	26.50
45	86.0	43.0	45.0	20.50	174.0	133.5	60.0	80.0	61.0	19.5	60.0	50.30	33.00

Size	Dimensions (mm)											Mass (kg)	
	K ₁	K ₂	K ₃	K ₄	N ₁	N ₆ ^{+0.5}	S ₂	S ₅	S ₉	T	V ₁	m	
15	17.20	18.30	3.80	3.80	6.0	8.55	M4	4.4	M2.5x5	60.0	5.4	0.22	
20	14.80	14.80	5.65	5.65	7.5	10.0	M5	6.0	M2.5x6	60.0	6.0	0.46	
25	20.80	20.85	7.00	7.00	9.0	11.3	M6	7.0	M3x6.5	60.0	7.5	0.67	
30	21.00	21.70	7.25	7.25	12.0	12.0	M8	9.0	M3x6.5	80.0	7.0	1.11	
35	23.75	25.40	7.00	7.00	13.0	15.5	M8	9.0	M3x6.5	80.0	8.0	1.71	
45	35.55	37.75	10.50	10.50	18.0	17.0	M10	14.0	M3x6.5	105.0	10.0	3.24	

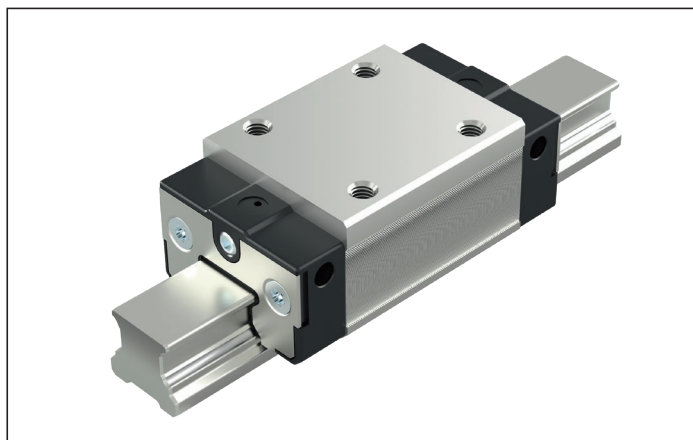

SNH – slimline, normal, high – R205E

**Dynamic characteristics**Travel speed: $v_{\max} = 5 \text{ m/s}$ Acceleration: $a_{\max} = 500 \text{ m/s}^2$ (If $F_{\text{comb}} > 2.8 \cdot F_{\text{pr}}$: $a_{\max} = 50 \text{ m/s}^2$)**Note**

Can be used on all BSCL ball guide rails KSE-...-SNS

Options and material numbers

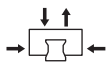
Size	Ball runner blocks with size	Preload class			Accuracy class			Standard seal pre-lubricated
		C0	C1	C2	N	H	P	
15	R205E 1	9			4	3	–	20
			1		4	3	2	20
				2	–	3	2	20
25	R205E 2	9			4	3	–	20
			1		4	3	2	20
				2	–	3	2	20
30	R205E 7	9			4	3	–	20
			1		4	3	2	20
				2	–	3	2	20
35	R205E 3	9			4	3	–	20
			1		4	3	2	20
				2	–	3	2	20
45	R205E 4	9			4	3	–	20
			1		4	3	2	20
				2	–	3	2	20

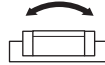
Size	Load capacities (N)			Load moments (Nm)					
	 $C_{50}^{1)}$	$C_{100}^{2)}$	C_0	 $M_{t50}^{1)}$	$M_{t100}^{2)}$	M_{t0}	 $M_{L50}^{1)}$	$M_{L100}^{2)}$	M_{L0}
15	11,500	9,100	11,700	98	78	100	79	63	82
25	27,500	21,800	30,600	340	270	380	280	220	310
30	39,300	31,200	42,200	590	470	640	450	360	490
35	54,100	42,900	56,600	970	770	1,030	720	570	760
45	78,100	62,000	83,000	1,790	1,420	1,930	1,320	1,050	1,420

1) Dynamic load capacity and load moments based on a travel life of 50,000 m.

2) Dynamic load capacity and load moments based on a travel life of 100,000 m.

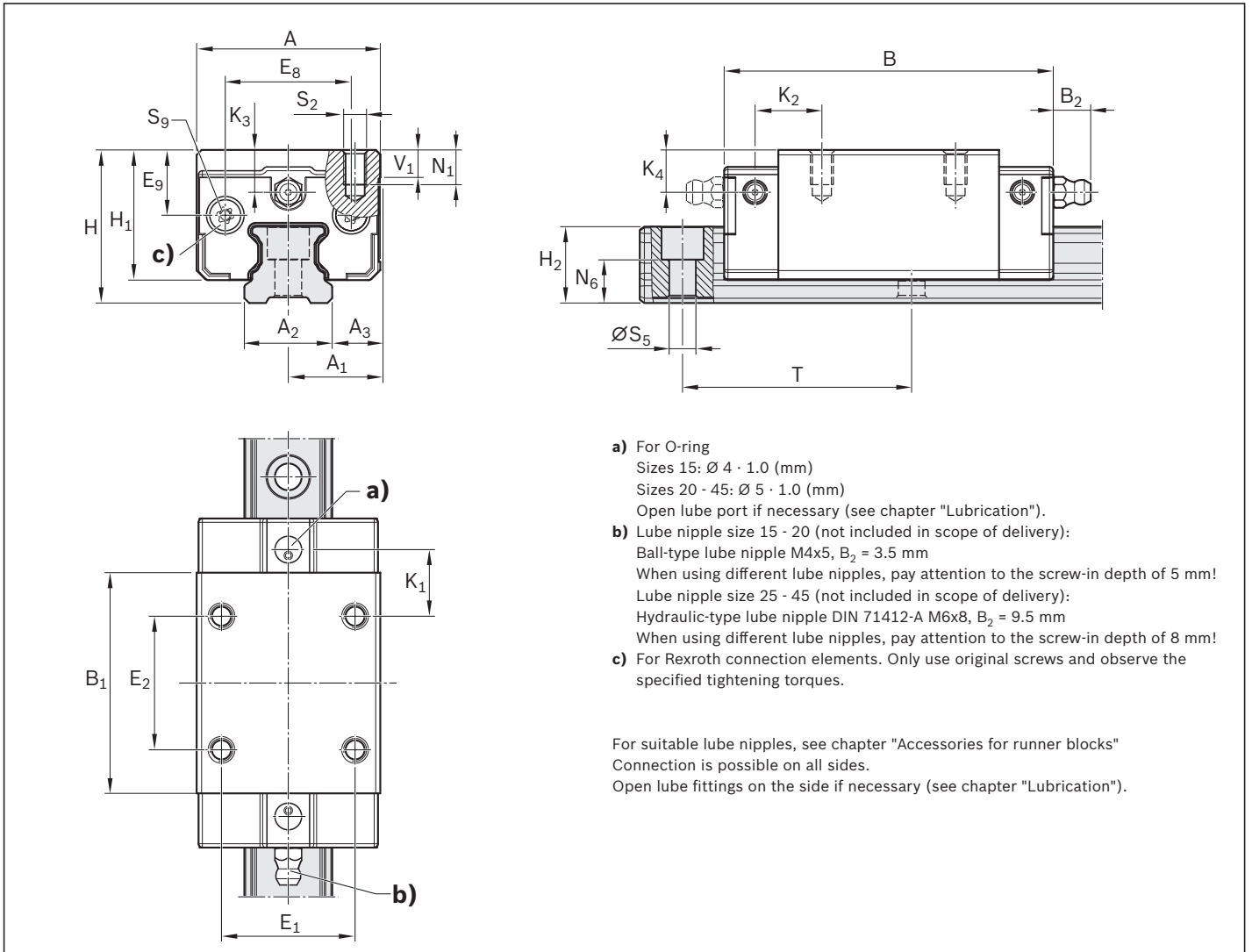

Size	Dimensions (mm)												
	A	A ₁	A ₂	A ₃	B ^{+0.5}	B ₁	E ₁	E ₂	E ₈	E ₉	H	H ₁	H ₂
15	34.0	17.0	15.0	9.50	58.2	39.2	26.0	26.0	20.5	11.8	28.0	23.90	14.10
25	48.0	24.0	23.0	12.50	86.2	57.8	35.0	35.0	33.0	17.0	40.0	34.00	20.00
30	60.0	30.0	28.0	16.00	97.7	67.4	40.0	40.0	42.0	17.25	45.0	38.35	23.00
35	70.0	35.0	34.0	18.00	110.5	77.0	50.0	50.0	50.0	22.7	55.0	47.40	26.50
45	86.0	43.0	45.0	20.50	137.5	97.0	60.0	60.0	61.0	29.5	70.0	60.30	33.00

Size	Dimensions (mm)											Mass (kg)	
	K ₁	K ₂	K ₃	K ₄	N ₁	N ₆ ^{±0.5}	S ₂	S ₅	S ₉	T	V ₁	m	m
15	10.0	11.1	7.8	7.8	6.0	8.55	M4	4.4	M2.5x5	60.0	5.4		0.20
25	17.45	17.5	11.0	11.0	9.0	11.3	M6	7.0	M3x6.5	60.0	7.5		0.59
30	20.0	20.7	10.25	10.25	12.0	12.0	M8	9.0	M3x6.5	80.0	7.0		0.95
35	20.5	22.15	14.0	14.0	13.0	15.5	M8	9.0	M3x6.5	80.0	8.0		1.57
45	27.3	29.5	20.5	20.5	18.0	17.0	M10	14.0	M3x6.5	105.0	10.0		3.03

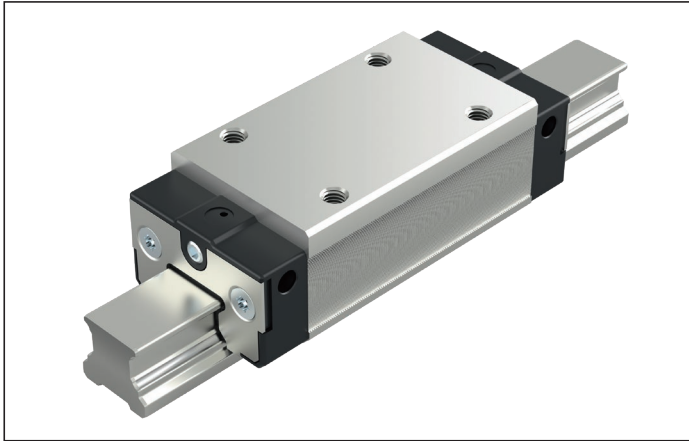

SLH – slimline, long, high – R205F

**Dynamic characteristics**Travel speed: $v_{\max} = 5 \text{ m/s}$ Acceleration: $a_{\max} = 500 \text{ m/s}^2$ (If $F_{\text{comb}} > 2.8 \cdot F_{\text{pr}}$: $a_{\max} = 50 \text{ m/s}^2$)**Note**

Can be used on all BSCL ball guide rails KSE-...-SNS

Options and material numbers

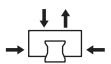
Size	Ball runner blocks with size	Preload class			Accuracy class			Standard seal
		C0	C1	C2	N	H	P	pre-lubricated
25	R205F 2	9			4	3	–	20
			1		4	3	2	20
				2	–	3	2	20
30	R205F 7	9			4	3	–	20
			1		4	3	2	20
				2	–	3	2	20
35	R205F 3	9			4	3	–	20
			1		4	3	2	20
				2	–	3	2	20
45	R205F 4	9			4	3	–	20
			1		4	3	2	20
				2	–	3	2	20

Size	Load capacitys (N)			Load moments (Nm)					
	 $C_{50}^{1)}$	$C_{100}^{2)}$	C_0	 $M_{t50}^{1)}$	$M_{t100}^{2)}$	M_{t0}	 $M_{L50}^{1)}$	$M_{L100}^{2)}$	M_{L0}
25	35,300	28,000	44,200	440	350	550	490	390	620
30	49,100	39,000	58,800	740	590	890	770	610	920
35	69,300	55,000	81,600	1,260	1,000	1,480	1,300	1,030	1,530
45	99,800	79,200	120,000	2,320	1,840	2,780	2,380	1,890	2,860

1) Dynamic load capacity and load moments based on a travel life of 50,000 m.

2) Dynamic load capacity and load moments based on a travel life of 100,000 m.

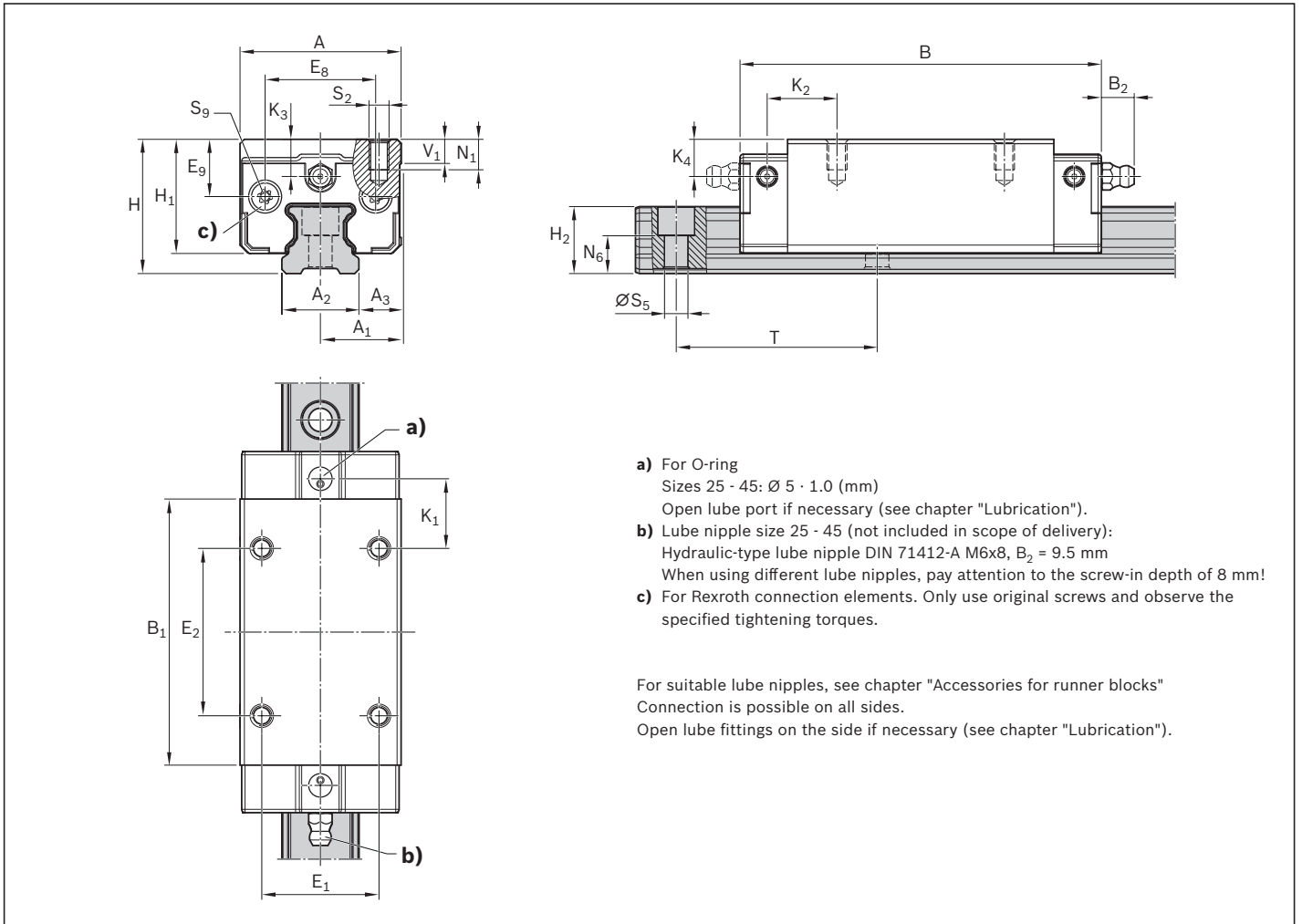

Size	Dimensions (mm)												
	A	A ₁	A ₂	A ₃	B ^{+0.5}	B ₁	E ₁	E ₂	E ₈	E ₉	H	H ₁	H ₂
25	48.0	24.0	23.0	12.50	107.9	79.5	35.0	50.0	33.0	17.00	40.0	34.00	20.00
30	60.0	30.0	28.0	16.00	119.7	89.4	40.0	60.0	42.0	17.25	45.0	38.35	23.00
35	70.0	35.0	34.0	18.00	139.0	105.5	50.0	72.0	50.0	22.70	55.0	47.40	26.50
45	86.0	43.0	45.0	20.50	174.0	133.5	60.0	80.0	61.0	29.50	70.0	60.30	33.00

Size	Dimensions (mm)											Mass (kg)	
	K ₁	K ₂	K ₃	K ₄	N ₁	N ₆ ^{+0.5}	S ₂	S ₅	S ₉	T	V ₁		m
25	20.80	20.85	11.00	11.00	9.0	11.3	M6	7.0	M3x6.5	60.0	7.5		0.79
30	21.00	21.70	10.25	10.25	12.0	12.0	M8	9.0	M3x6.5	80.0	7.0		1.31
35	23.75	25.40	14.00	14.00	13.0	15.5	M8	9.0	M3x6.5	80.0	8.0		2.11
45	35.55	37.75	20.50	20.50	18.0	17.0	M10	14.0	M3x6.5	105.0	10.0		4.11

Ball guide rail ordering example

Ordering ball guide rails

The material number is composed of the code numbers for the individual options. Each option is coded in a material number digit.

BSCL ball guide rail SNS		R2055	7	0	3	31	,xx mm
Size	1 = size 15						
	8 = size 20						
	2 = size 25						
	7 = size 30						
	3 = size 35						
4 = size 45							
Cover	0 = plastic caps						
Accuracy	4 = accuracy class N						
	3 = accuracy class H						
	2 = accuracy class P						
Version	3x = number of partial sections						
	51 = factory length						
Length	xx = rail length in mm						

BSCL ball guide rail type key

BALL GUIDE RAIL CS	KSE	-	0	3	0	-	S	N	S	-	H	-	M	A	-	A	K
			1				2				3		4			5	

1 Size	
Characteristic	Designation
015	Size 15
020	Size 20
025	Size 25
030	Size 30
035	Size 35
045	Size 45

3 Accuracy class	
Characteristic	Designation
N	Normal
H	High
P	Precision

5 Cover	
Characteristic	Designation
AK	With plastic caps

2 Format	
Characteristic	Designation
SNS	Slimline, normal, standard height

4 Fastening	
Characteristic	Designation
MA	Bolting from above

Recommended rail lengths

Ball guide rails can be manufactured in principal in any length. However, if possible, recommended rail lengths should be used at which the rails are cut in the middle between two fastening bores. Recommended rail lengths are more cost effective. The recommended rail length (preferred length) can be calculated as follows, or determined alternatively in the online configurators.

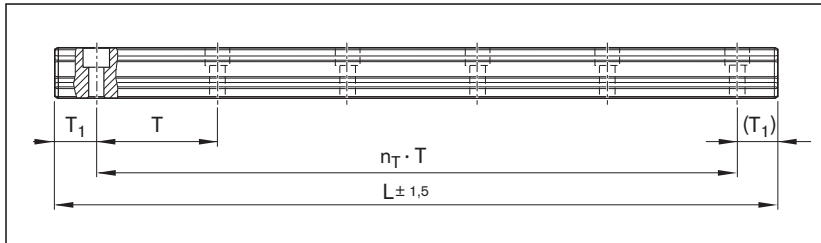

L	= Recommended rail length	(mm)
L _W	= Desired rail length	(mm)
T	= Pitch	(mm)
T _{1S}	= Preferred dimension	(mm)
n _B	= Number of holes	(-)
n _T	= Number of spaces	(-)

a) Calculated from desired length:

$$L = \left(\frac{L_W}{T} \right)^* \cdot T - 4$$

* Round up quotient L_W/T to the nearest whole number!

b) Calculated from desired number of bores:

$$L = n_B \cdot T - 4 \text{ mm}$$

c) Calculated from desired number of divisions:

$$L = n_T \cdot T + 2 \cdot T_{1S}$$

Ordering example: one-piece rail of recommended rail length (up to L_{max}):

- ▶ Ball guide rail SNS
- ▶ Size 30
- ▶ Accuracy class H
- ▶ One-piece
- ▶ Calculated rail length 1676 mm,
(20 · T, preferred dimension T_{1S} = 38 mm;
number of holes n_B = 21)

Ordering data

Part number; rail length (mm)

T₁ / n_T · T / T₁ (mm)

R2055 703 31, 1676 mm

38 / 20 · 80 / 38 mm

Ordering example: multi-piece rail of recommended rail length (longer than L_{max}):

- ▶ Ball guide rail SNS
- ▶ Size 30
- ▶ Accuracy class H
- ▶ Calculated rail length 5116 mm, 2 sections
(63 · T, preferred dimension T_{1S} = 38 mm;
number of holes n_B = 64)

Ordering data

Material number with number of partial sections,
rail length (mm)

T₁ / n_T · T / T₁ (mm)

R2055 703 32, 5116 mm

38 / 63 · 80 / 38 mm

In the case of rail lengths above L_{max}, partial sections approved by Rexroth are joined together.

SNS – with plastic caps – R2055

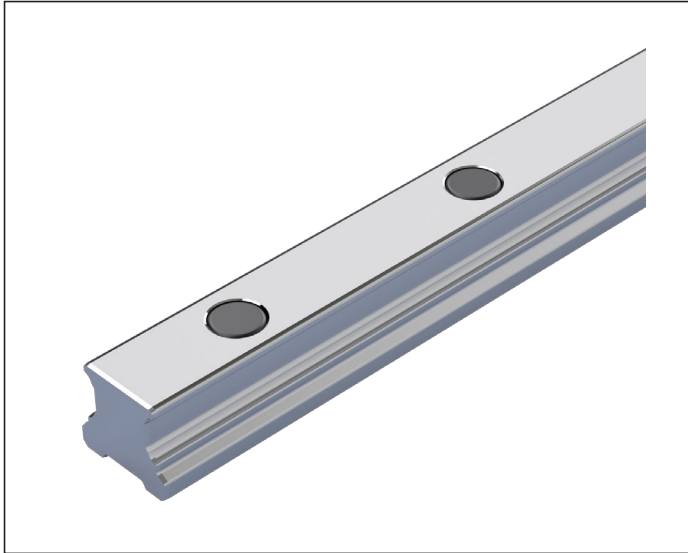
**Ball guide rails KSE-...-SNS****For bolting from above with plastic caps****Notes**

- ▶ Observe the instructions for mounting!
Please request the "Mounting instructions for ball rail systems."
- ▶ To avoid damage to the runner block, the fastening bores of the guide rails must be sealed with plastic caps.
- ▶ Plastic caps included in scope of supply.

Options and material numbers

Size	Ball guide rail with size	Accuracy class			Number of partial sections., Rail length L (mm),		Spacing T (mm)	Recommended rail length in accordance with formula $L = n_B \cdot T - 4 \text{ mm}$	
		N	H	P	One-piece	Composite		Maximum number of holes n_B	
15	R2055 10	4	3	2	31,	3,	60	64	
20	R2055 80	4	3	2	31,	3,	60	64	
25	R2055 20	4	3	2	31,	3,	60	64	
30	R2055 70	4	3	2	31,	3,	80	48	
35	R2055 30	4	3	2	31,	3,	80	48	
45	R2055 40	4	3	2	31,	3,	105	36	

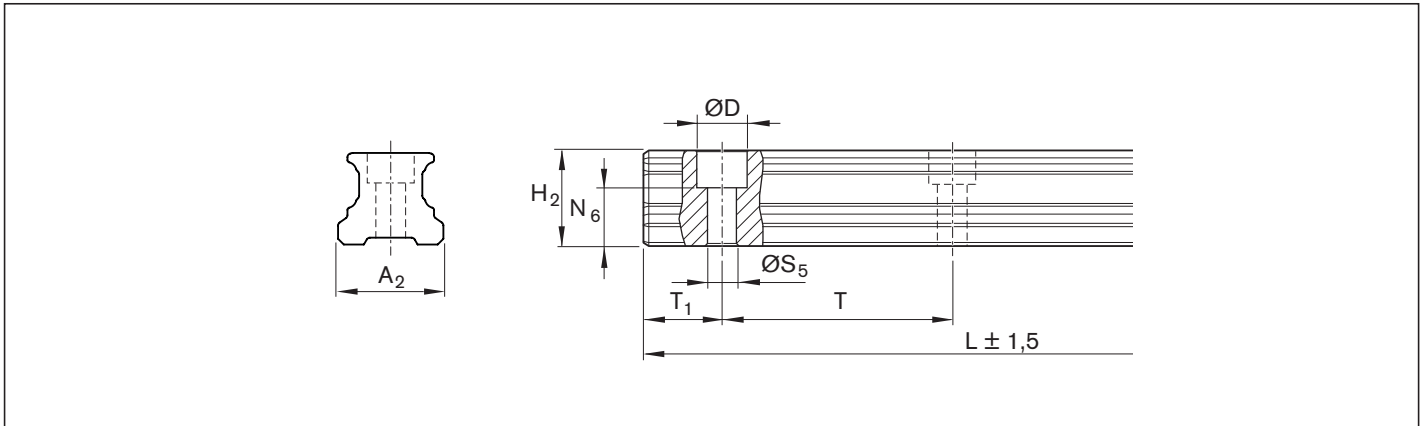

Size	Dimensions (mm)											Mass m (kg/m)
	A ₂	D	H ₂	L _{max}	N ₆ ^{±0.5}	S ₅	T	T _{1 min}	T _{1S} ¹⁾	T _{1 max}		
15	15	7.4	14.1	3 836	8.55	4.5	60	10	28.0	50	1.2	
20	20	9.4	17.0	3,836	10.00	6.0	60	10	28.0	50	1.8	
25	23	11.0	20.0	3,836	11.30	7.0	60	10	28.0	50	2.6	
30	28	15.0	23.0	3,836	12.00	9.0	80	12	38.0	68	3.6	
35	34	15.0	26.5	3,836	15.50	9.0	80	12	38.0	68	5.1	
45	45	20.0	33.0	3,776	17.00	14.0	105	16	50.5	89	7.7	

1) Preferred dimension T_{1S} with tolerances ± 0.75 recommended.

Overview of factory lengths

Size	Accuracy class		
	N	H	P
15	R205510451	R205510351	R205510251
20	R205580451	R205580351	R205580251
25	R205520451	R205520351	R205520251
30	R205570451	R205570351	R205570251
35	R205530451	R205530351	R205530251
45	R205540451	R205540351	R205540251

Factory lengths are guide rails without end machining which are only available in four-meter sections. A factory length has an overall length of approx. 4,150 mm with a usable length (good length) of at least 3,600 mm in one piece of the respective accuracy class. The maximum good length is 4,150 mm. The good length is specified on the packaging and charged upon delivery.

Note

- ▶ When ordering factory lengths, the plastic caps must be ordered separately. See the chapter "Accessories".
- ▶ The packaging of guide rails should only be opened with a suitable tool. Bosch Rexroth provides an appropriate tool for this purpose under part number R320105175.

Overview – accessories

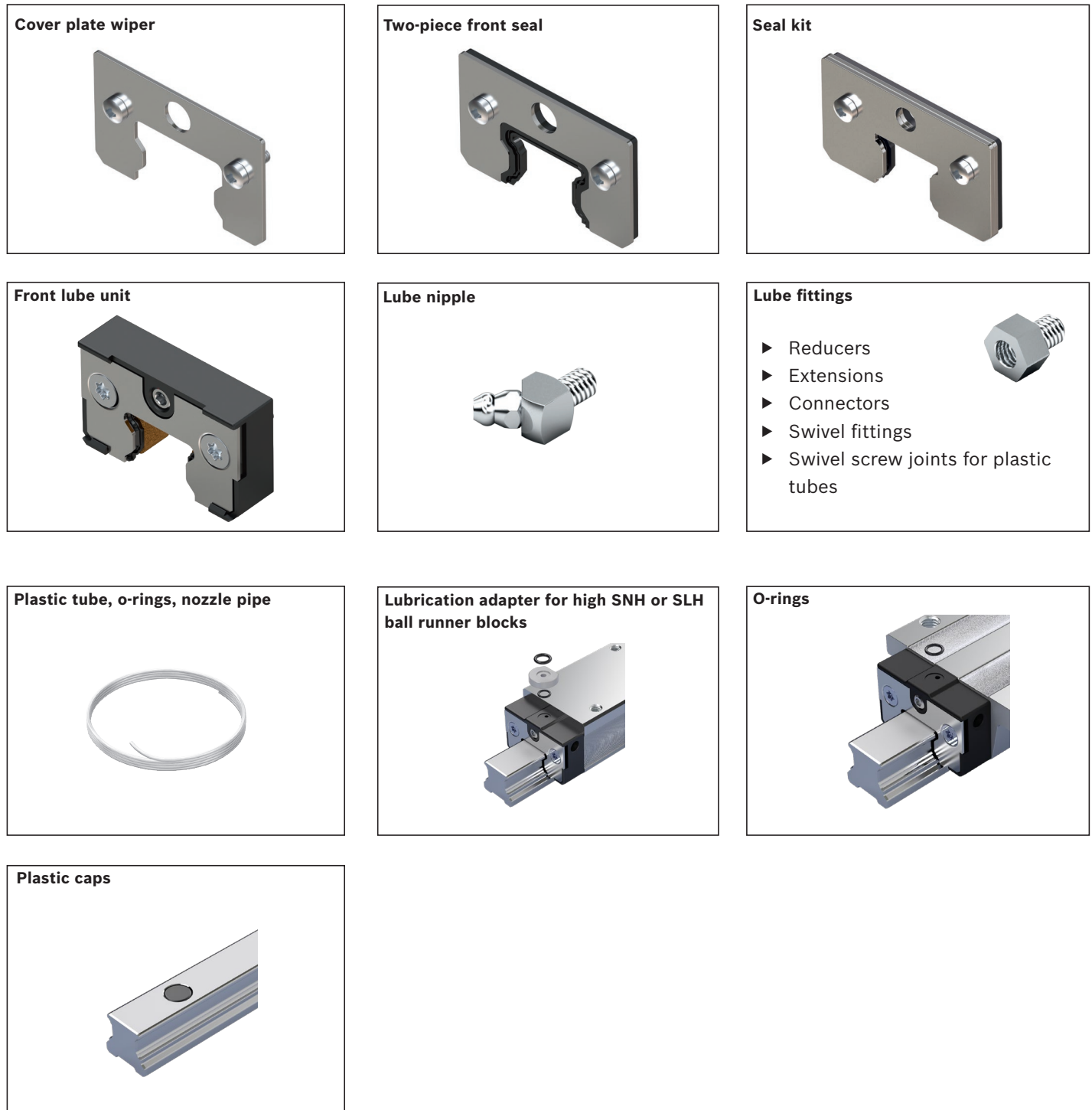

Cover plate wiper

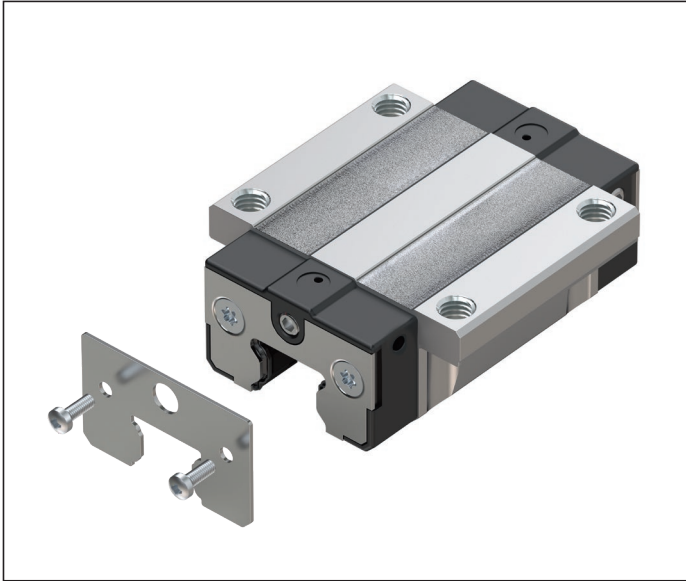

- ▶ Material: Corrosion resistant steel as per EN 10088
- ▶ Design: bright
- ▶ Precision design with a maximum gap dimension of 0.1 to 0.3 mm

Instruction for mounting

- ▶ The seal kit must be used when combining the cover plate wiper with the front seal. See seal kit.
- ▶ The fastening screws are included.
- ▶ When mounting, make sure that there is a uniform gap between the ball guide rail and the cover plate wiper.
- ▶ Observe the minimum screw-in depth for the end-face lube connection.
- ▶ Observe the mounting instructions.

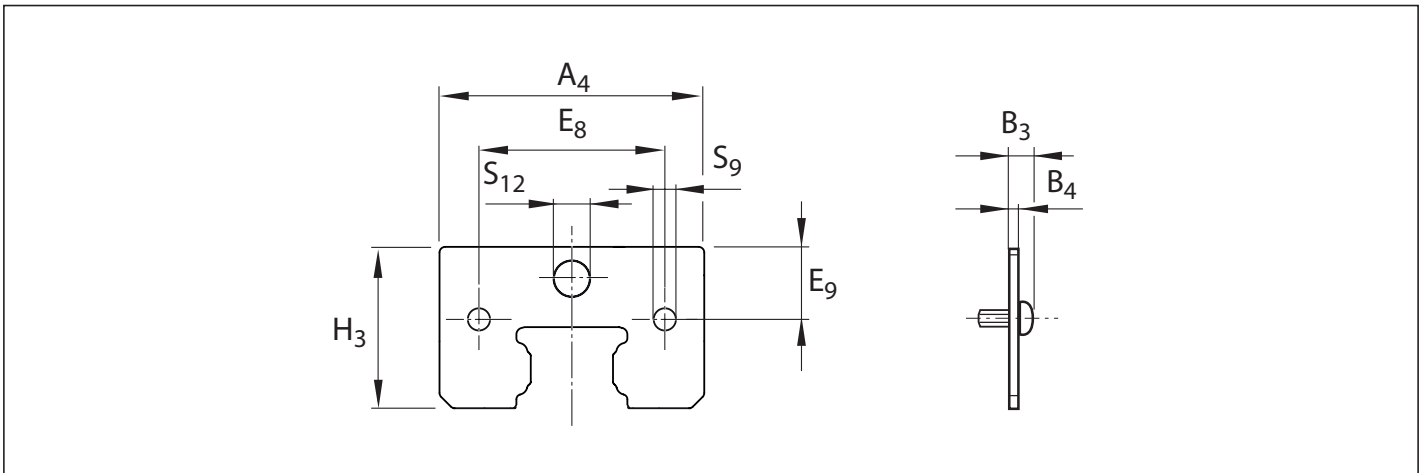

Size	Material number	Dimensions (mm)								Mass m (g)
		A ₄	B ₃	B ₄	E ₈	E ₉	H ₃	S ₉	S ₁₂	
15	R205Z 100 00	31.5	3.0	1.0	20.5	7.40	19.30	2.8	4.3	4.8
20	R205Z 800 00	42.2	3.0	1.0	29.0	8.70	23.40	2.8	5.0	7.5
25	R205Z 200 00	46.0	3.5	1.0	33.0	11.35	27.85	2.8	7.0	9.8
30	R205Z 700 00	58.0	3.5	1.0	42.0	12.40	32.90	3.5	7.0	13.9
35	R205Z 300 00	68.0	4.0	1.5	50.0	14.20	38.30	3.5	7.0	27.2
45	R205Z 400 00	83.3	4.0	1.5	61.0	17.70	48.00	3.5	7.0	39.9

Front seal

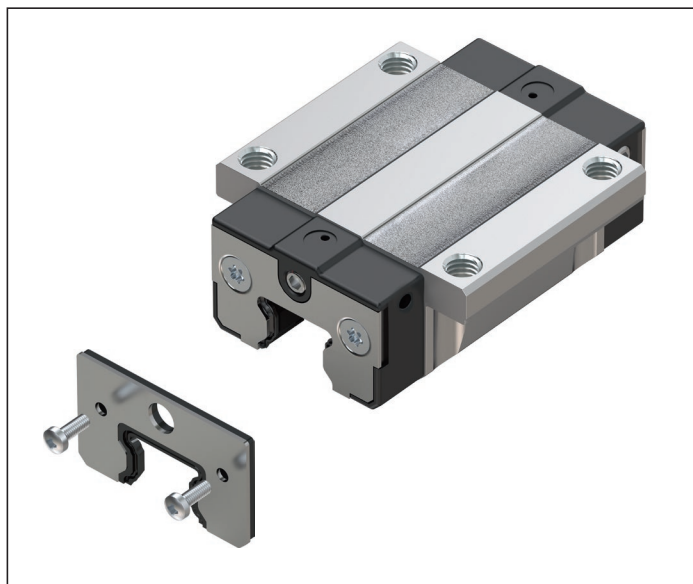

Two-piece

- ▶ Material: Corrosion resistant steel as per DIN EN 10088 with plastic seal ring
- ▶ Design: bright

Instruction for mounting

- ▶ The fastening screws are included.
- ▶ Observe the minimum screw-in depth for the end-face lube connection.
- ▶ The seal kit must be used when combining the front seal with the cover plate wiper. See seal kit.
- ▶ Observe the mounting instructions.

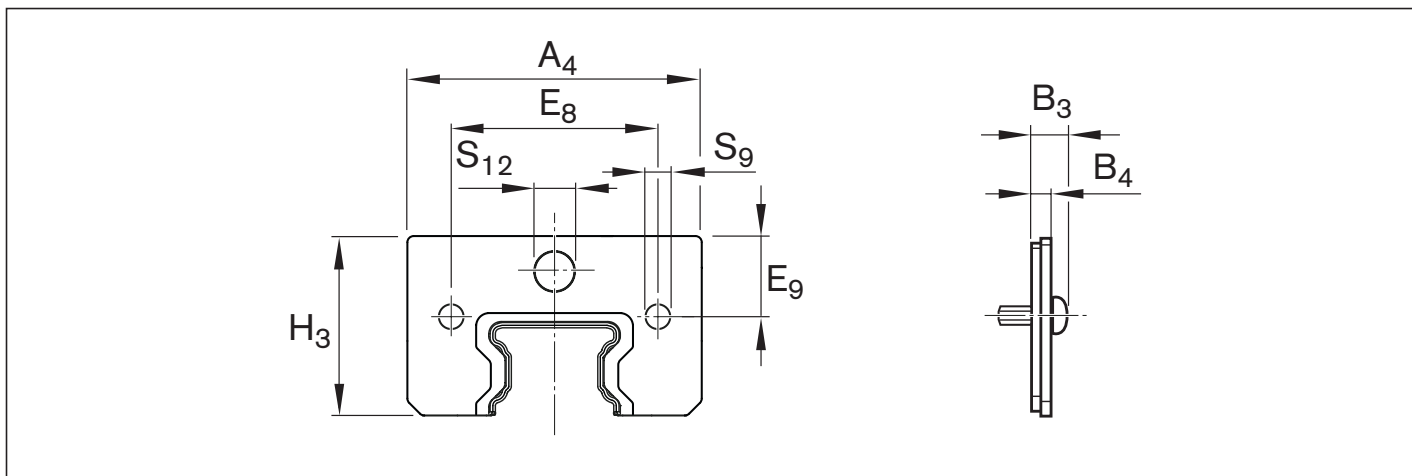

Size	Material number	Dimensions (mm)								Mass m (g)
		A ₄	B ₃	B ₄	E ₈	E ₉	H ₃	S ₉	S ₁₂	
15	R205Z 110 00	31.5	4.5	2.5	20.5	7.40	19.30	2.8	4.3	5.2
20	R205Z 810 00	42.2	4.5	2.5	29.0	8.70	23.40	2.8	5.0	7.9
25	R205Z 210 00	46.0	5.0	2.5	33.0	11.35	27.85	3.5	7.0	11.4
30	R205Z 710 00	58.0	5.0	2.5	42.0	12.40	32.90	3.5	7.0	16.2
35	R205Z 310 00	68.0	5.5	3.0	50.0	14.20	38.30	3.5	7.0	28.5
45	R205Z 410 00	83.3	5.5	3.0	61.0	17.70	48.00	3.5	7.0	42.6

Seal kit

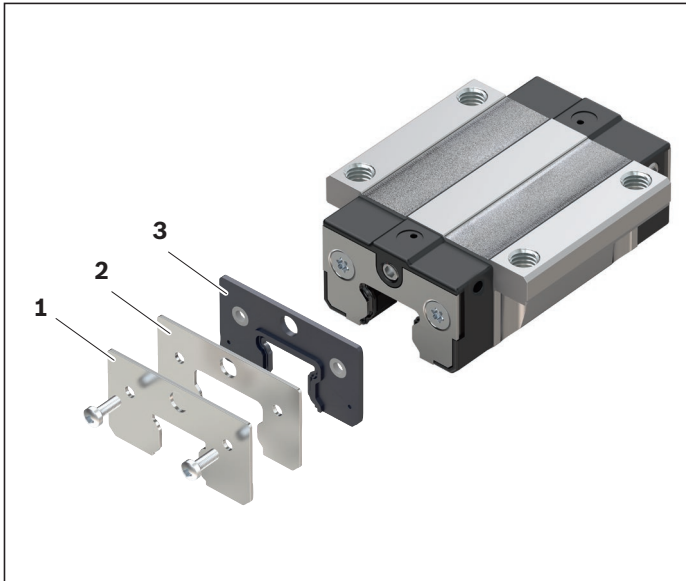

- 1** Cover plate wiper
- 2** Reinforcing plate
- 3** Two-piece front seal

Instruction for mounting

- ▶ The seal kit is recommended when combining the cover plate wiper with the front seal.
- ▶ The fastening screws are included.
- ▶ Observe the minimum screw-in depth for the end-face lube connection.
- ▶ Observe the mounting instructions.

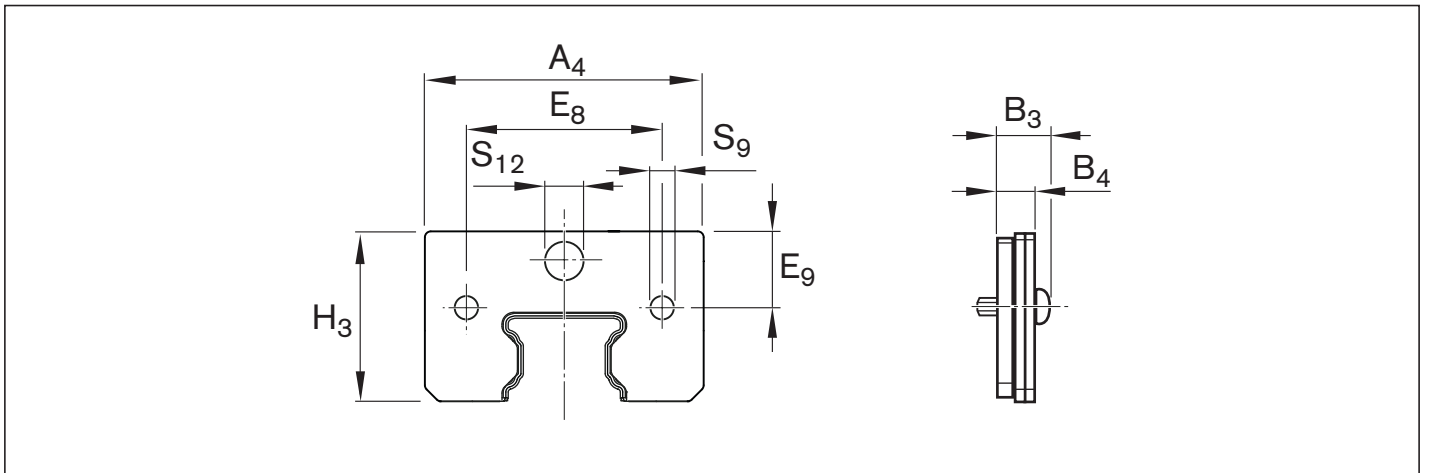

Size	Material number	Dimensions (mm)								Mass m (g)
		A ₄	B ₃	B ₄	E ₈	E ₉	H ₃	S ₉	S ₁₂	
15	R205Z 190 10	31.5	5.5	3.5	20.5	7.40	19.30	2.8	4.3	9.0
20	R205Z 890 10	42.2	5.5	3.5	29.0	8.70	23.40	2.8	5.0	14.4
25	R205Z 290 10	46.0	6.0	3.5	33.0	11.35	27.85	2.8	7.0	19.6
30	R205Z 790 10	58.0	6.0	3.5	42.0	12.40	32.90	3.5	7.0	28.5
35	R205Z 390 10	68.0	7.0	4.5	50.0	14.20	38.30	3.5	7.0	54.1
45	R205Z 490 10	83.3	7.0	4.5	61.0	17.70	48.00	3.5	7.0	80.9

Front lube units

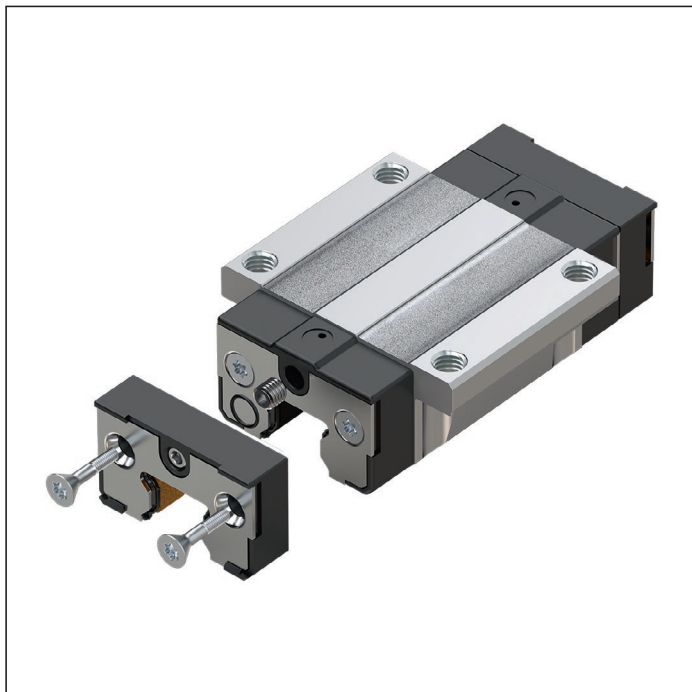

For extended travel distances without relubrication

Advantages for mounting and operation

- ▶ Ball runner block only requires initial lubrication with grease
- ▶ Front lube units on both sides of the ball runner block
- ▶ Low lubricant loss
- ▶ Reduced oil consumption
- ▶ No lubrication lines
- ▶ Max. operating temperature 60°C
- ▶ Lube connection on the end-face of the front lube unit is suitable for lubricating the ball runner block with grease.

Instruction for mounting

- ▶ The required mounting accessories (coated screws, seals and lube nipples) are supplied along with the units.
- ▶ Mount a front lube unit on both sides of the ball runner block!
- ▶ Observe the mounting instructions.

Notes:

Material: Special plastic

The front lube units are supplied ready-filled with oil (Mobil SHC 639) and can be mounted after basic lubrication of the ball runner blocks.

Rexroth recommends replacing the front lube units every 3 years at the latest and relubricating the ball runner block before mounting the new front lube unit.

Relubrication of the ball runner blocks

In clean operating environments, the ball runner blocks can be relubricated with grease (Dynalub 510) at the end-face. Relubrication of the ball runner blocks **with grease lubricant** see chapter "Lubrication".

⚠ An initial lubrication of the ball runner blocks with grease lubricant is required before mounting the front lube units! See chapter "Lubrication".

⚠ If other types of lubricant oil are used, please consider the compatibility of the lubricants and the travel distance!

⚠ If other types of lubricants are used, this may lead to a reduction in the lubrication intervals, performance losses in short stroke applications and the load capacities. Possible chemical interactions between the plastic materials, lubricants and preservative oils must also be taken into account.

The recommended lubrication intervals depend on environmental factors, load and load type.

Examples of environmental factors include swarf, mineral abrasion (or similar), solvent and temperature.

Examples of loads and stress types are oscillations, shocks and tilting.

⚠ The conditions of use are unknown to the manufacturer. Only the user's own trials or accurate monitoring can yield safety across lubrication intervals.

⚠ Do not use water-based coolant/lubricant on the ball guide rails and ball runner block!

Lubricant distribution

Due to the special design of the lubricant distribution, lubrication occurs primarily where it is needed: directly on the raceways and the top surfaces of the ball guide rails.

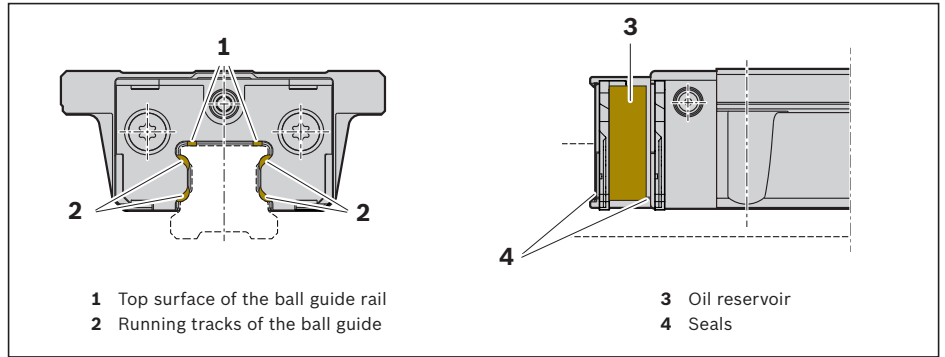

Travel distance

Size	Possible travel distance s with front lube units (km)
15	10,000
20	10,000
25	10,000
30	10,000
35	5,000
45	2,500

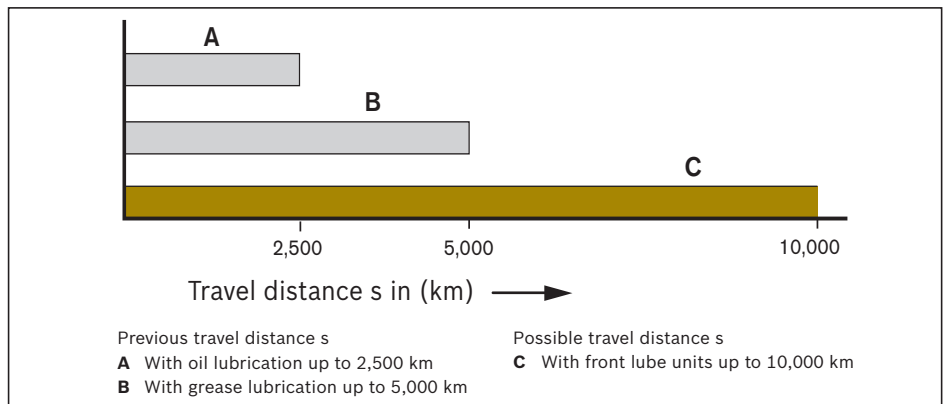

Load-dependent relubrication intervals for ball runner blocks with front lube units

This applies to the following conditions:

- ▶ Ball runner block lubricants: Dynalub 510 (NLGI 2 grease) or, alternatively, Castrol Longtime PD 2 (NLGI 2 grease)
- ▶ Front lube units lubricant: Mobil SHC 639 (synthetic oil)
- ▶ Maximum speed: $v_{max} = 2 \text{ m/s}$
- ▶ No media pressurization
- ▶ Standard seals
- ▶ Ambient temperature: $T = 20 - 30 \text{ }^\circ\text{C}$

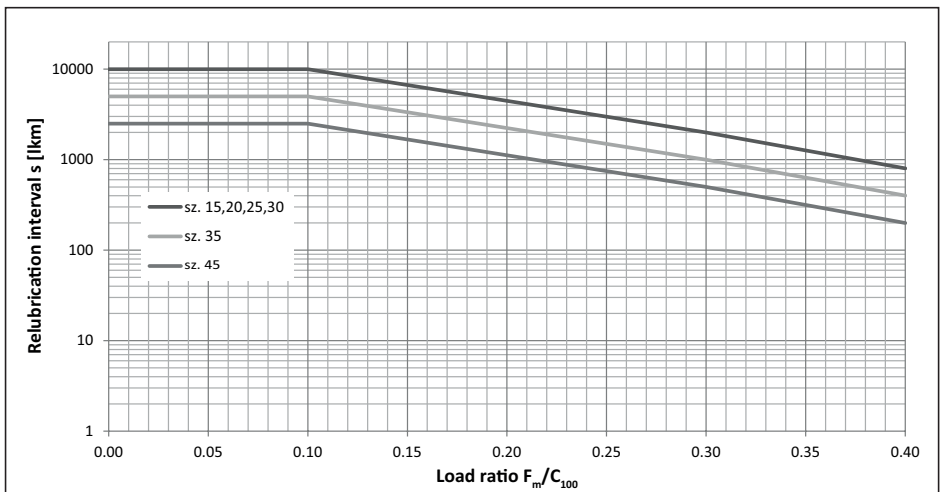

Key

- C_{100} = dynamic load capacity (N)
- F_m = dynamically equivalent load on bearing (N)
- F_m/C_{100} = load ratio
- s = relubrication interval as travel distance (km)

Front lube units

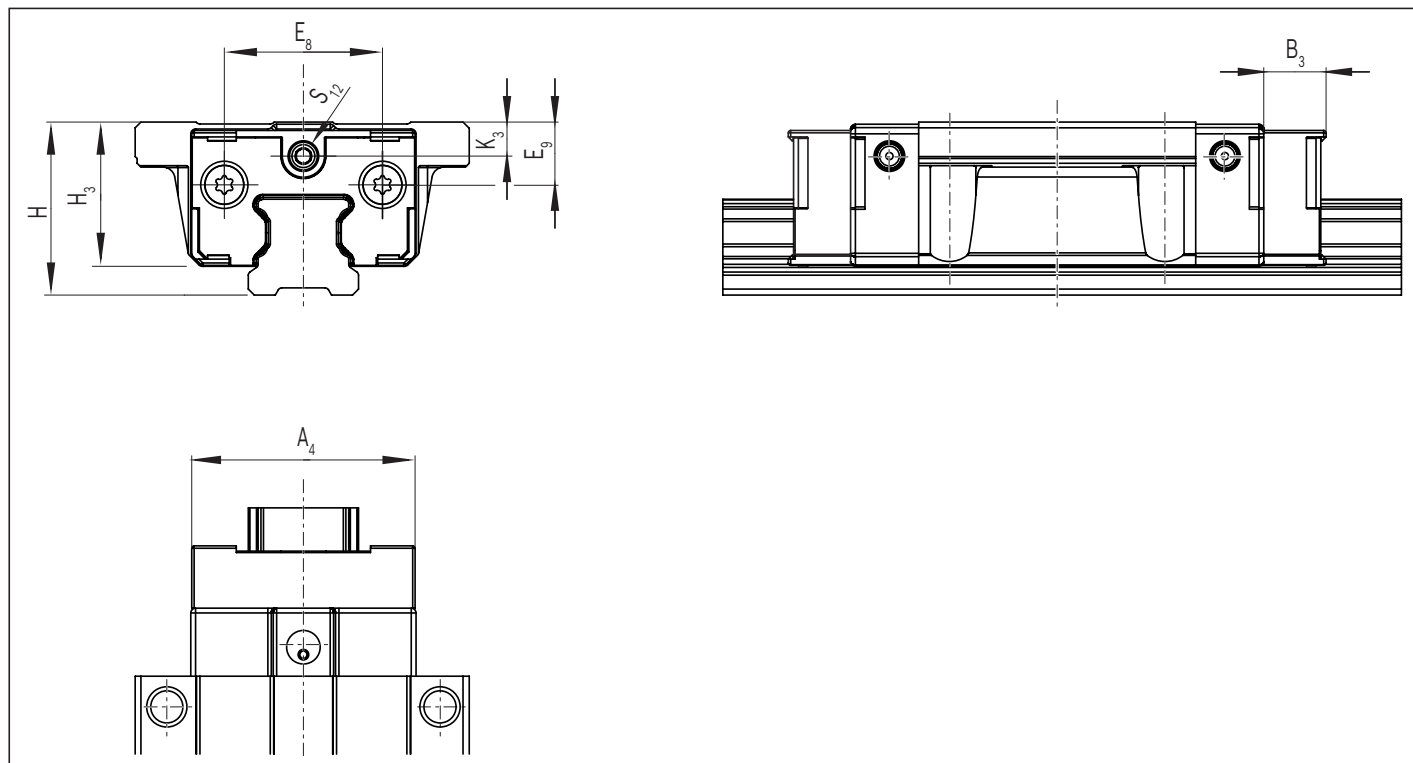

Size	Material number	Dimensions (mm)								Mass m (g)
		A ₄	B ₃	E ₈	E ₉	H	H ₃	K ₃	S ₁₂	
15	R205Z 125 00	31.7	11.5	20.5	7.90	24.1	19.90	1.95	M4	9.6
20	R205Z 825 00	42.5	12.5	29.0	10.25	30.1	25.10	2.50	M4	17.1
25	R205Z 225 00	46.6	13.0	33.0	11.35	36.1	29.90	4.50	M6	23.8
30	R205Z 725 00	58.2	13.5	42.0	12.60	40.0 ¹⁾	34.00 ¹⁾	11.00 ¹⁾	M6	33.8
					17.25 ¹⁾	45.0 ¹⁾	38.35 ¹⁾	10.25 ¹⁾		
35	R205Z 325 00	68.6	14.0	50.0	15.80	55.0 ¹⁾	47.40 ¹⁾	14.00 ¹⁾	M6	52.8
					22.70 ¹⁾	55.0 ¹⁾	47.40 ¹⁾	14.00 ¹⁾		
45	R205Z 425 00	83.5	14.5	61.0	19.60	70.0 ¹⁾	60.30 ¹⁾	20.50 ¹⁾	M6	78.3
					29.50 ¹⁾	70.0 ¹⁾	60.30 ¹⁾	20.50 ¹⁾		

1) For roller runner block S.H (small ... high)

Lubrication adapter

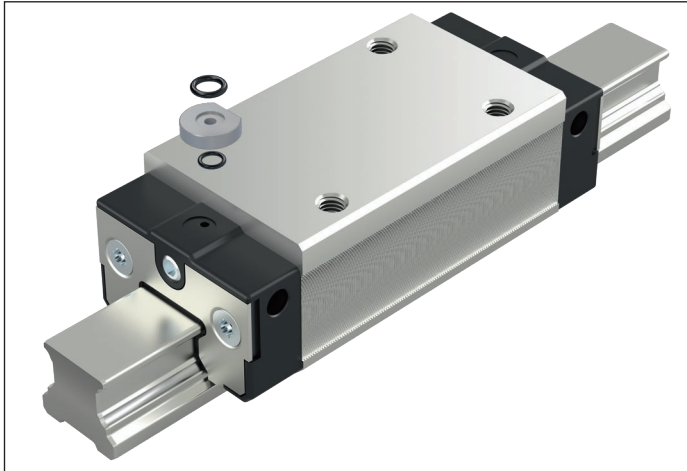

For oil and grease lubrication from above with high ball runner blocks SNH R205E or SLH R205F

- ▶ Material: Plastic
- ▶ Packaging unit: 1 unit

Instruction for mounting

- ▶ O-rings are provided.
- ▶ Before mounting, use a heated metal tip to open the lube port in the ball runner block.
- ▶ For more details, see the chapter "Lubrication and maintenance".

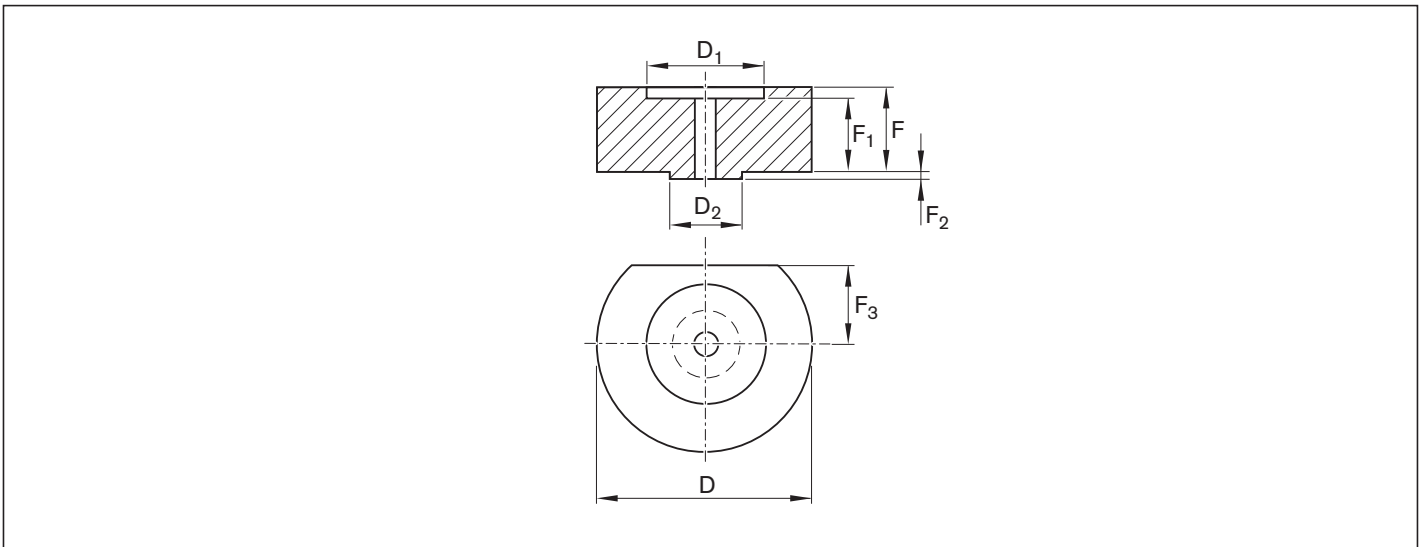

Size	Material number	Dimensions (mm)							Mass m (g)
		D	D ₁	D ₂	F	F ₁	F ₂	F ₃	
15	R1621 100 05	12	6.2	3.4	3.7	3.1	0.5	3.20	0.5
25	R1621 200 05	15	7.2	4.4	3.8	3.2	0.5	5.85	0.9
30	R1621 700 05	16	7.2	4.4	2.8	2.2	0.5	6.10	0.7
35	R1621 300 05	18	7.2	4.4	6.8	6.2	0.5	6.80	2.2
45	R1621 400 05	20	7.2	4.4	9.8	9.2	0.5	8.30	4.1

Lube nipple, lube fittings

Ball-type lube nipple

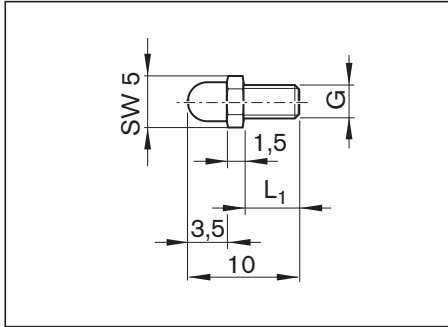

Material number	Dimensions (mm)		Mass (g)
	G	L ₁	
R3417 006 01	M4	5	0.5

Funnel-type lube nipple according to DIN 3405

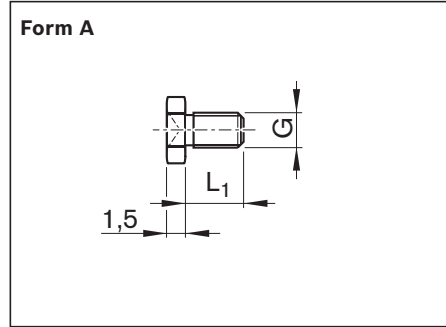

Material number	Dimensions (mm)		Mass (g)
	G	L ₁	
R3417 069 09	M4	5	0.3

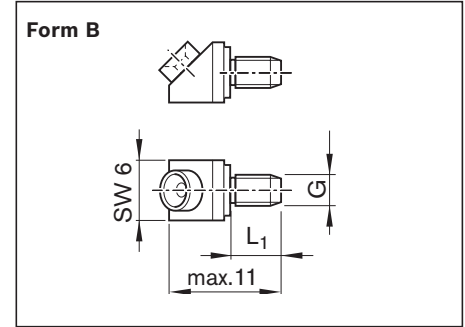

Material number	Dimensions (mm)		Mass (g)
	G	L ₁	
R3417 070 09	M4	5	1.5

Hydraulic-type lube nipple according to DIN 71412

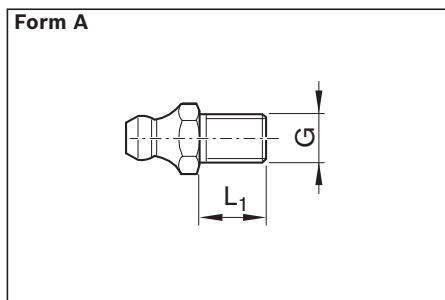

Material number	Dimensions (mm)		Mass (g)
	G	L ₁	
R3417 008 02	M6	8	2.6
R3417 016 02 ¹⁾			

Hydraulic-type lube nipple according to DIN 71412

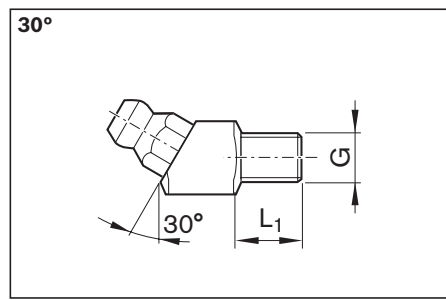

Material number	Dimensions (mm)		Mass (g)
	G	L ₁	
R3417 023 02	M6	8	7.4

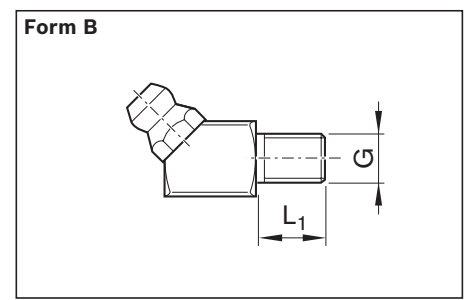

Material number	Dimensions (mm)		Mass (g)
	G	L ₁	
R3417 007 02	M6	8	7.4

1) Lube nipple Resist NR II made of corrosion-resistant steel according to DIN EN 10088

Lube fittings

Reducers

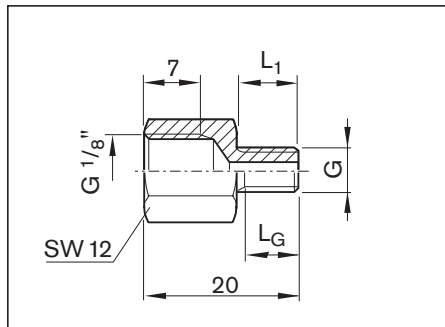

Material number	Dimensions (mm)			Mass (g)
	G	L ₁	L _G	
R3455 030 34	M6	8	6.5	7.5

Connectors

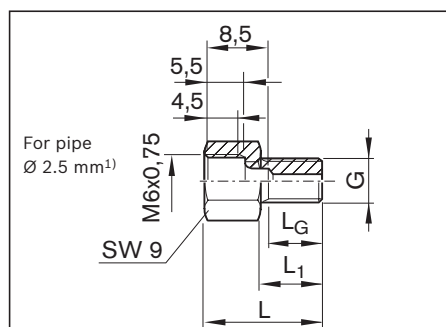

Material number	Dimensions (mm)				Mass (g)
	G	L	L ₁	L _G	
R3455 030 38	M6	15.5	8	6.5	4.1

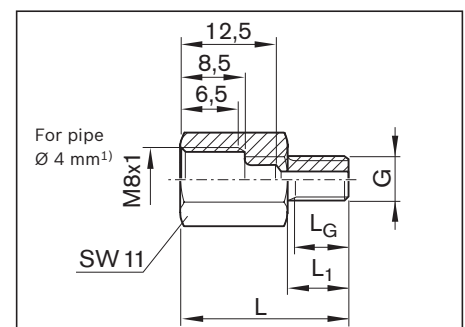

Material number	Dimensions (mm)				Mass (g)
	G	L	L ₁	L _G	
R3455 030 37	M6	22	8	6.5	8.8

1) For connections according to DIN 2353 (solderless tube fittings)

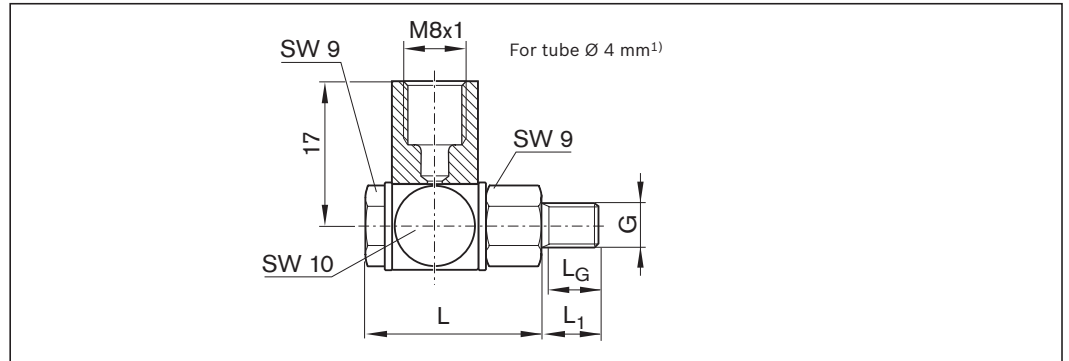
Swivel fittings

Material number	Dimensions (mm)				Mass (g)
	G	L	L ₁	L _G	
R3417 018 09	M6	21.5	8	6.5	18.6

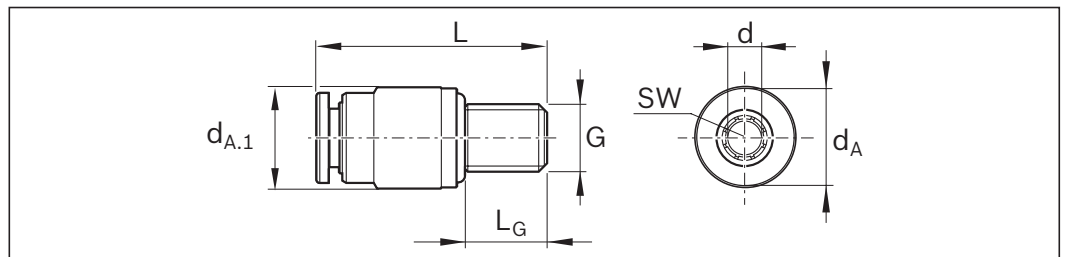
**Straight connectors²⁾
for plastic tubes and metal pipes**

Material number	Dimensions (mm)							Mass (g)
	d _A	d _{A.1}	d±0.1	G	L	L _G	SW	
R3417 071 09	6.5	6.5	3	M4	16.2	5	1.5 ³⁾	1.4
R3417 075 09	9.0	9	4	M6	24.5	8	2.5	4.6
R3417 076 09	11.0	11	6	M6	26	8	2.5	6.2

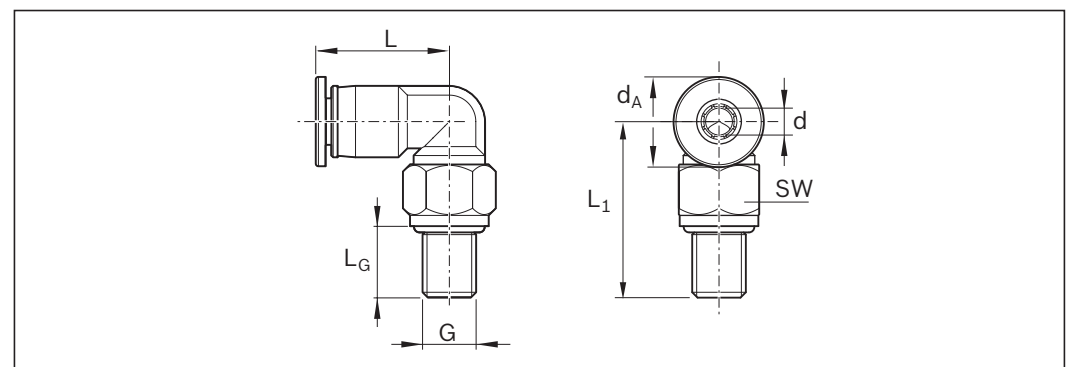
**Elbow plug-in connections
rotatable²⁾ for plastic tubes and metal pipes**

Material number	Dimensions (mm)							Mass (g)
	d _A	d±0.1	G	L	L ₁	L _G	SW	
R3417 072 09	6.5	3	M4	18.0	19	5	6 ³⁾	1.7
R3417 078 09	9.0	4	M6	18.1	18.1	8	9	10.8
R3417 079 09	11.0	6	M6	20.8	18.1	8	9	12.9

- 1) For connections according to DIN 2353 (solderless tube fittings)
- 2) Max. lubrication pressure: 30 bar (exerting slow pressure with manual grease gun)
- 3) Max. tightening torque M_A = 0.5 Nm

Lube fittings, O-rings

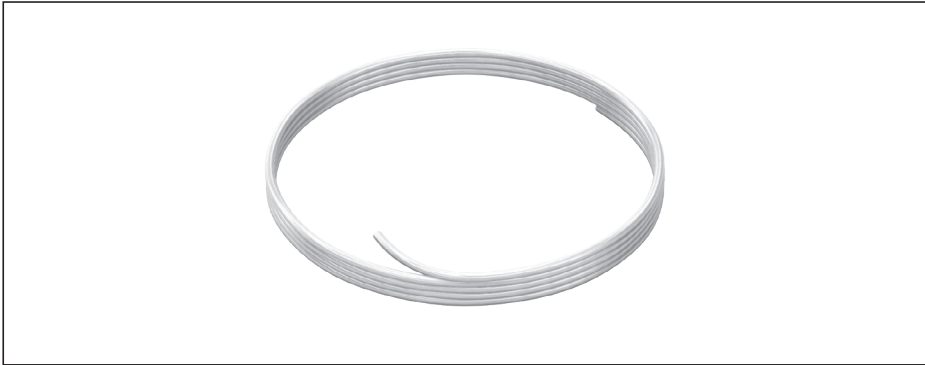

**Plastic tube Ø 3 mm
for lube fittings**

Material number	Dimensions			Mass (kg)
	External Ø (mm)	Internal Ø (mm)	Length (m)	
R3499 287 00	3	1.7	50	0.4

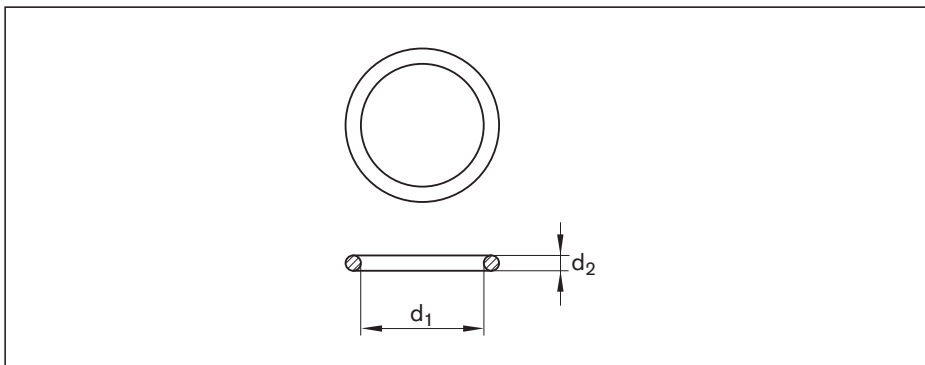

O-rings

Material number	d ₁ x d ₂ (mm)
R3411 130 01	4 x 1.0
R3411 131 01	5 x 1.0
R3411 003 01	6 x 1.5

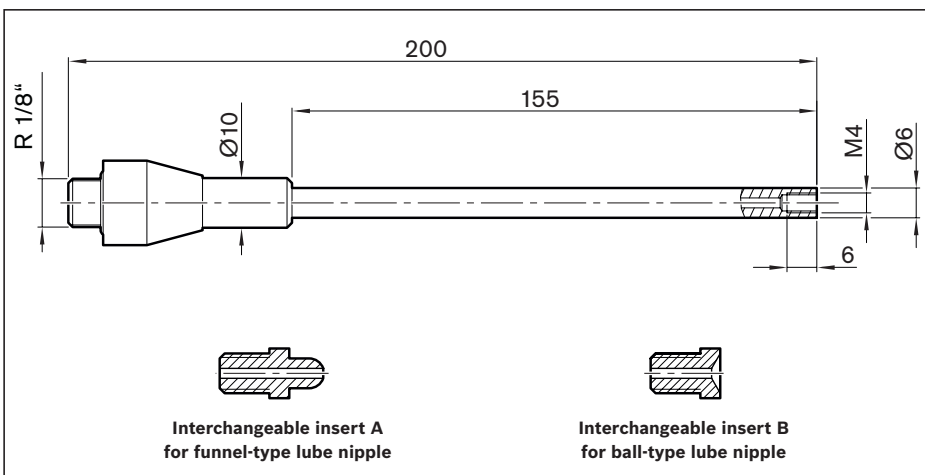

Nozzle pipe

For manual grease guns.

For the lubrication of funnel-type and ball-type lube nipples for size 20 BSCL ball runner blocks.

Scope of delivery:

- 1 x nozzle pipe
- 1 x interchangeable insert A for funnel-type lube nipple
- 1 x interchangeable insert B for ball-type lube nipple

Material number	Mass (g)
R345503106	158

Plastic caps

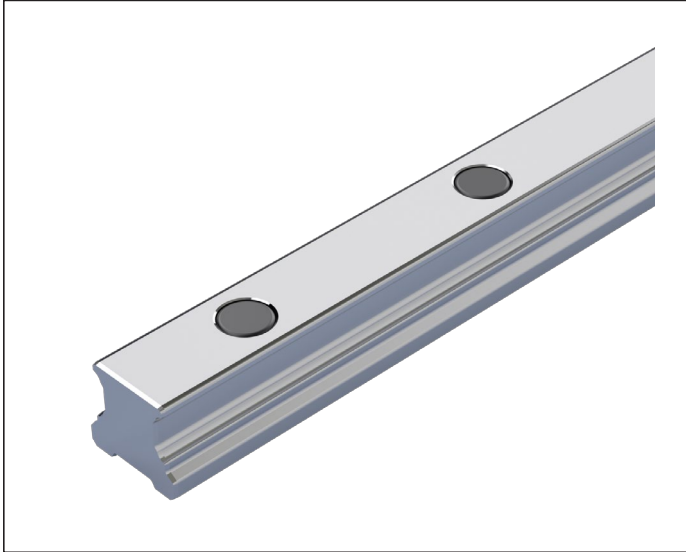

To avoid damage to the runner block, the caps of the guide rails must be sealed with plastic fastening hole plugs.

Size	Material numbers of individual cap	Number of caps required for a factory length	Mass (g)
15	R1605 100 80	67	0.05
20	R1605 800 80	67	0.10
25	R1605 200 80	67	0.30
30	R1605 300 80	50	0.60
35	R1605 300 80	50	0.60
45	R1605 400 80	38	1.00

Cardboard box opener



- ▶ Tool for opening the guide rails packaging.
- ▶ Prevents risk of injury

Ordering data

Material number R320105175

General instructions for mounting

The following notes relating to mounting apply to all ball rail systems. Please also observe the notes in the assembly instructions. They can be downloaded from the Rexroth media directory.

- ⚠ In the case of overhead installation (hanging installation) or vertical installation, the ball runner block can release from the ball guide rail due to the balls being lost or broken. Secure the ball runner block from falling!
We recommend protection against falling loads!
- ⚠ Rexroth ball rail systems are high-quality products. Use with extreme care during transport and mounting.
- ⚠ All steel parts are protected with anti-corrosion oil. These preservatives do not have to be removed as long as the recommended lubricants are used.

Installation examples

Ball guide rails

Each ball guide rail has ground reference surfaces on both sides.

Ball runner blocks

Each ball runner block has a ground reference edge on one side (see dimension V_1 in the dimension drawings).

Possibilities for side fixing:

- 1 Reference edges
- 2 Clamping strips
- 3 Locating pins

Mounting with fixing of both ball guide rails and both ball runner blocks

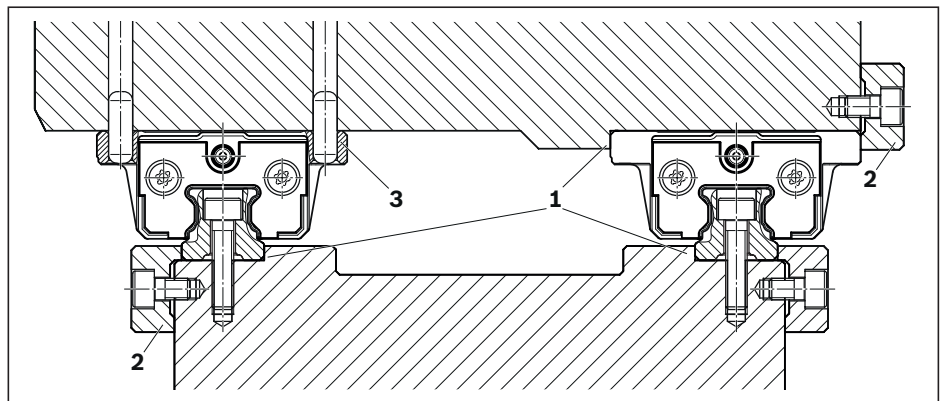

Mounting with fixing of one ball guide rail and one ball runner block

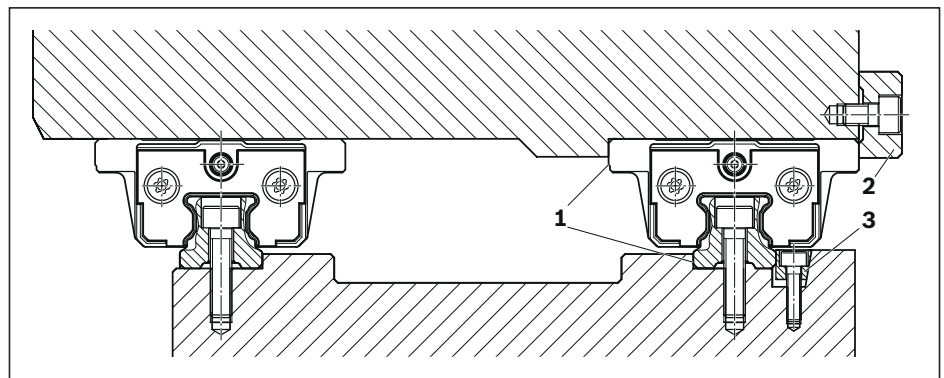

Notes

- ▶ Before installing the components, clean and degrease all mounting surfaces.
- ▶ Please ask for the "Mounting Instructions for ball rail systems".
- ▶ After mounting, it should be possible to move the ball runner block easily.
- ▶ Ball guide rails without side fixing have to be aligned straight and parallel when mounting, preferably using a straightedge.
- ▶ Recommended limits for side load if no additional lateral retention is provided; see the chapter "Fastening".

Installation tolerances

Vertical offset

If you comply with the permissible vertical offset S_1 and S_2 , the effect on the service life is, in general, negligible.

Permissible vertical offset in transverse direction S_1

The tolerance for dimension H is to be deducted from the permissible vertical offset S_1 of the ball guide rails according to the table containing the accuracy classes in the chapter "General product description".

If $S_1 < 0$ applies, select other tolerances in the event of a combination of accuracy classes. See chapter "Accuracy classes".

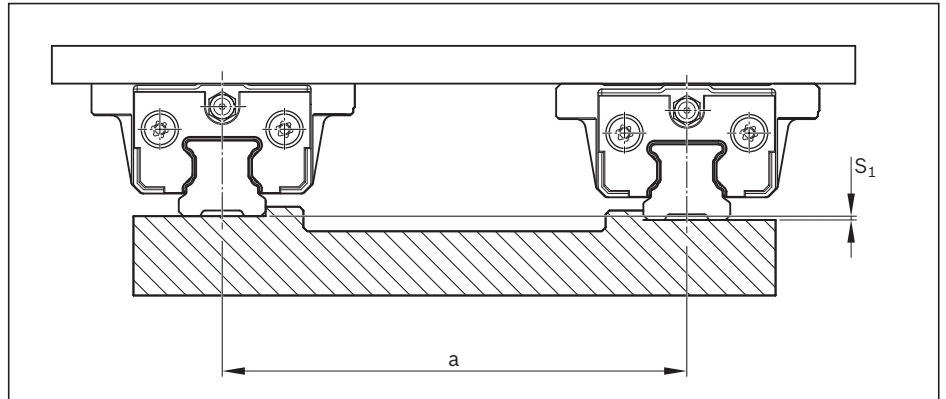

Calculation factor Y for preload class

C0	C1	C2
$4.3 \cdot 10^{-4}$	$2.8 \cdot 10^{-4}$	$1.7 \cdot 10^{-4}$

$$S_1 = a \cdot Y$$

Permissible vertical offset in longitudinal direction S_2

You must deduct from the permissible vertical offset S_2 of the ball runner blocks the "Max. difference of dimension H on one rail" tolerance according to the table containing the accuracy classes in the chapter "General product description".

You must deduct from the permissible vertical offset S_2 of the ball runner blocks the "Max. difference of dimension ΔH on one rail" tolerance according to the table containing the accuracy classes in the chapter "General product description". If $S_2 < 0$ applies, select other tolerances in the event of a combination of accuracy classes. See chapter "Accuracy classes".

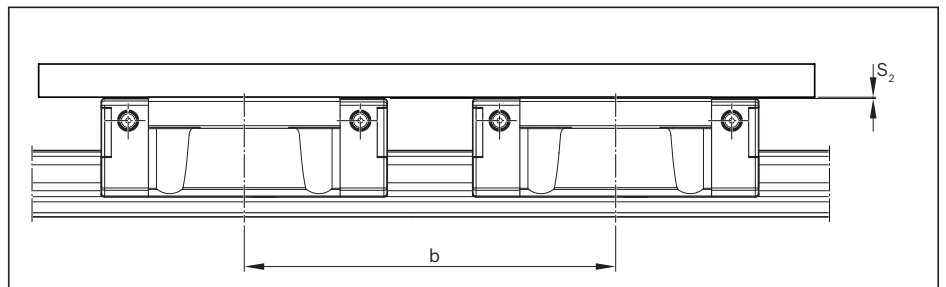

Calculation factor X for ball runner block length

Normal	Long
$4.3 \cdot 10^{-5}$	$3.0 \cdot 10^{-5}$

$$S_2 = b \cdot X$$

Key

- S_1 = Permissible vertical offset of the ball guide rails (mm)
- a = Centerline-to-centerline distance between the ball guide rails (mm)
- Y = Calculation factor transverse direction (-)
- S_2 = Permissible vertical offset of the ball runner blocks (mm)
- b = Centerline-to-centerline distance between the ball runner blocks (mm)
- X = Calculation factor longitudinal direction (-)

Preload classes

- C0 = Without preload (clearance)
- C1 = Moderate preload
- C2 = Medium preload

Installation tolerances

Parallelism offset of the mounted rails

Values measured on the ball guide rails and the ball runner blocks

The values for the parallelism offset P_1 apply to the entire standard range of ball runner blocks.

The parallelism offset P_1 causes a slight rise in the preload.

As long as the values specified in the table are met, the effect of parallelism offsets on the service life can generally be neglected.

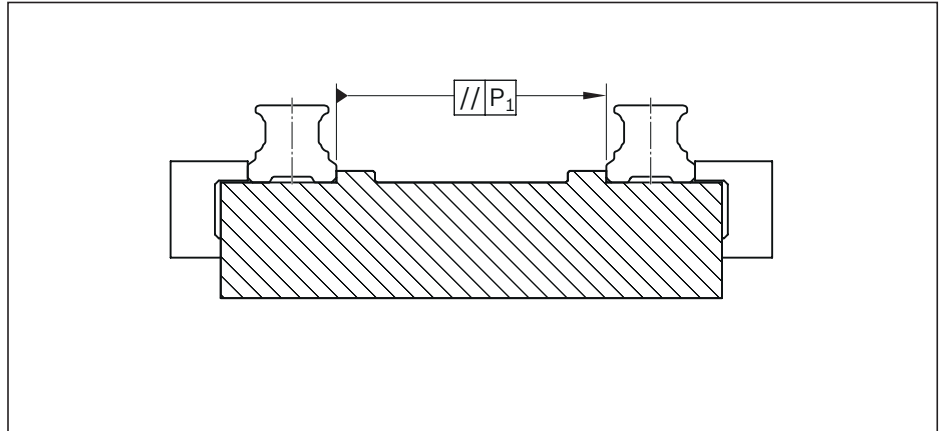

Preload classes

C0 = Without preload (clearance)

C1 = Moderate preload

C2 = Medium preload

	Size	Parallelism offset P_1 (mm) for preload class		
		C0	C1	C2
Steel ball runner blocks with precision installation¹⁾	15	0.015	0.009	0.005
	20	0.018	0.011	0.006
	25	0.019	0.012	0.007
	30	0.021	0.014	0.009
	35	0.023	0.015	0.010
	45	0.028	0.019	0.012

- 1)** The precision installation unit is a rigid, high-precision surrounding structure. With standard installation, the surrounding structure is of flexible design and it is possible to work with **double** the tolerance values of the parallelism offset.

Composite ball guide rails

Notes on ball guide rails

- ▶ Matching partial sections of a composite ball guide rail are identified as such by a label on the packaging. All partial sections of the same rail have the same serial rail number.
- ▶ The numbering is marked on the top of the ball guide rail.

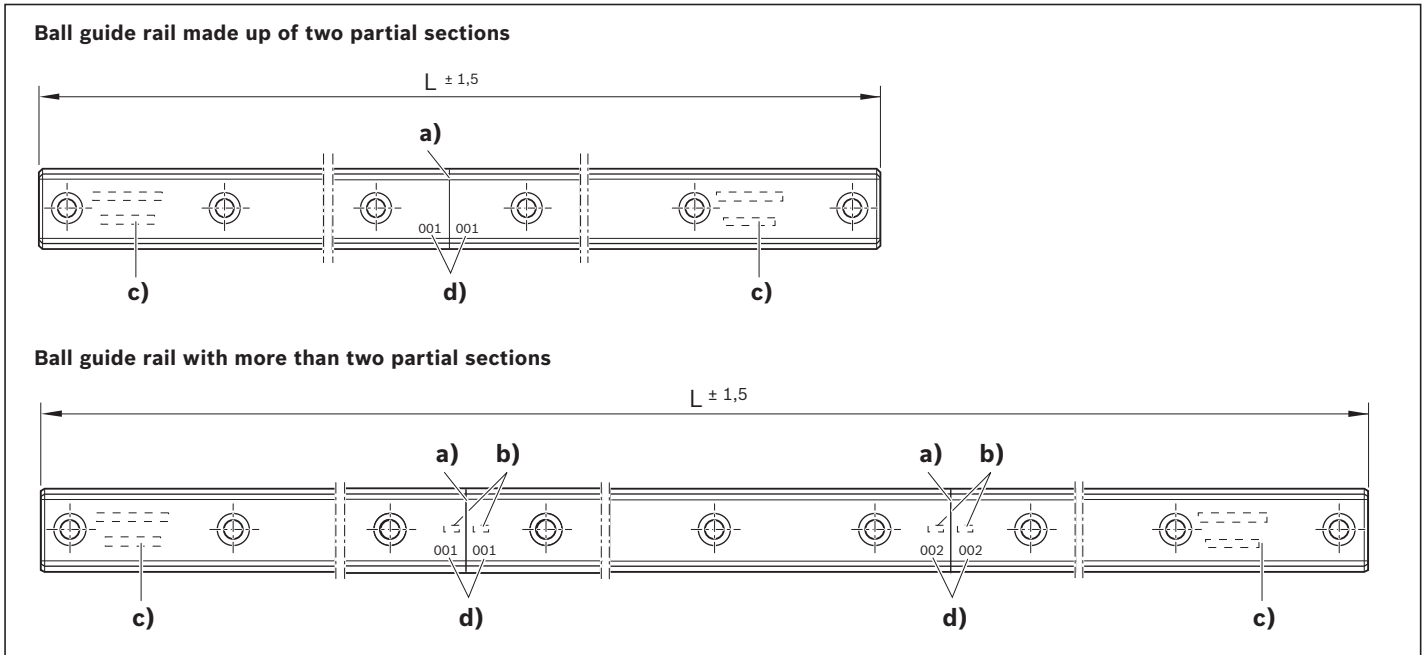

L = rail length (mm)
 n_B = number of holes (-)

- a) Joint
- b) Rail number
- c) Full rail identification on first and last sections
- d) Joint identification number

Note on adjacent structures

Permissible fastening bore tolerances for adjacent structures

Size	Hole position tolerance (mm)
15 - 35	∅ 0.2
45	∅ 0.3

For composite guide rails, the actual tolerances of the individual sections may sum up. In such case, the fastening bore holes in the connecting structure may lie outside of the tolerance and a rework of the connecting structure may be required.

Fastening

Calculating screw connections

The screw connections in Runner Blocks and Roller Guide Rails produce maximum traction forces $F_{0z \max}$, maximum static torsional moments $M_{0x \max}$ and maximum static side load $F_{0y \max}$ without stop strips that the linear guide can transfer.

The maximum load on a profiled rail system is defined not only by the static load capacity C_0 in accordance with ISO 14728 Part 2 and the static moments M_{t0} from the rolling contact, but also by the screw connections.

As a rule, ball runner blocks are fastened using 4 screws. Ball guide rails have one or two rows of screw connections in regular distances, whereby the screws located directly under the runner block are subject to the most stress.

If the runner block and rail are bolted with screws in the same strength class, the connection between the rail and the mounting base O3 is critical to the maximum forces and moments that can be transferred.

Calculation of the values in the table for strength class 8.8, 10.9 and 12.9 are taken from DIN 637 (August 2013):

Ball bearings – safety regulations for dimensioning and operation of Profiled Rail Systems with recirculating rolling elements. In comparison to the standard, the values determined by Bosch Rexroth include a higher safety factor.

Screw connections are calculated based on the dimensions in the catalog (screw sizes, runner block lengths, clamping lengths, screw-in depths, bore diameters, rail separations of the rail bore holes, rail width, etc.).

Deviant screw connections are to be recalculated according to VDI 2230. The maximum static traction force and maximum static torsional moment of a ball guide rail system are the product of the sum of the axial forces on the rail screws within the flow of forces. However, for the maximum static side load, the sum of the clamping forces on the rail screws within the flow of forces is crucial.

Input values for calculation:

- Friction coefficient in the thread $\mu_G = 0.125$
- Friction coefficient at the head surface $\mu_K = 0.125$
- Friction coefficient in the joint $\mu_T = 0.2$
- Tightening torque for torque wrench $\alpha_A = 1.5$

The applied friction coefficients and the tightening torque are common values in practice. Depending on the customer application and mounting procedure, the actual input parameters may deviate considerably from the assumptions. This must be checked after each sizing and tightening connections must be recalculated with actual values according to VDI 2230 as necessary. Even slight deviations from the assumptions in the Bosch Rexroth calculations lead to variations in tightening torque and maximum transferable static tension forces, torsional moments and lateral forces.

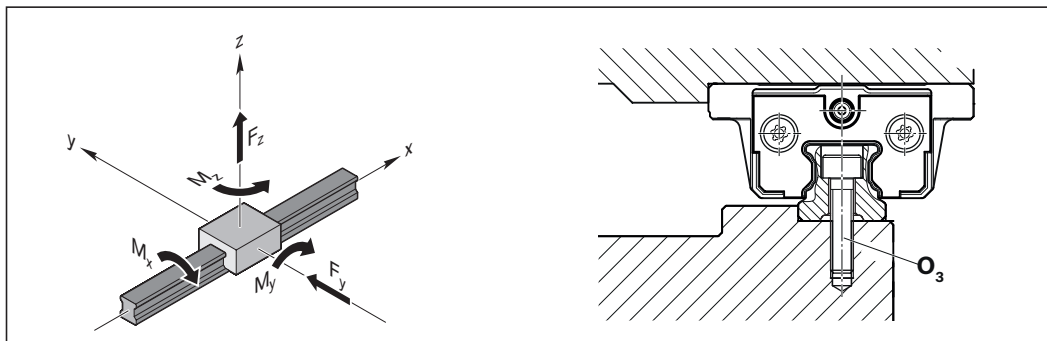

Fastening

Tightening torques for profiled rail systems

The tightening torques for screw strength classes 8.8, 10.9 and 12.9 were calculated for the dimensions of a Rexroth ball rail system. Detailed descriptions of the possible screw connections O1 to O6 can be found on the following pages.

Runner block

Size	FNS, FLS									SNS, SLS, SNH, SLH			
	for bolting from above					for bolting from below				for bolting from above			
	O4					O1				O5			
		8.8	10.9	12.9		8.8	10.9	12.9		8.8	10.9	12.9	
15	M5	6.3	9.2	11	M4	3.2	4.8	5.5	M4	3.1	4.6	5.4	
20	M6	11	16	18	M5	6.4	9.5	11	M5	6.3	9.2	11	
25	M8	26	38	44	M6	9.8	9.8	9.8	M6	11	16	18	
30	M10	51	74	87	M8	27	31	31	M8	26	38	44	
35	M10	51	74	87	M8	27	31	31	M8	26	38	44	
45	M12	87	130	130	M10	52	69	69	M10	51	74	87	

Guide rail

Size	for bolting from above			
	O3			
		8.8	10.9	12.9
15	M4	3,1	4,6	5,4
20	M5	6.4	9.4	11
25	M6	11	16	18
30	M8	26	38	44
35	M8	26	38	44
45	M12	88	110	110

Fastening

Maximum static traction forces and torsional moments on profiled rail systems

The screw connections in a profiled rail system can only transfer a limited traction force F_z or a limited torsional moment M_x . If these limit values are exceeded, the guideway will lift off of the adjacent structure. The permissible values for a guideway are the product of the maximum possible axial force on a screw connection in the Guide Rail. Exceeding the indicated maximum static load is not permissible.

The table values are guidelines for the permissible static traction force $F_{0z \max}$ and torsional moments $M_{0x \max}$ that are only applicable when the following conditions are met:

- Screw sizes, screw quantity and connecting dimensions as listed in the catalog
- Same fastening screw strength class for blocks and rails
- Steel adjacent structure
- Traction force F_z or torsional moment M_x are static
- Traction force F_z and torsional moment M_x do not occur simultaneously
- No interaction with side load F_y or longitudinal moment M_y/M_z

If these conditions are not met, recalculate the screw connection in accordance with VDI 2230. If the applied loads are just below the limit values, Bosch Rexroth also recommends checking the screw connections.

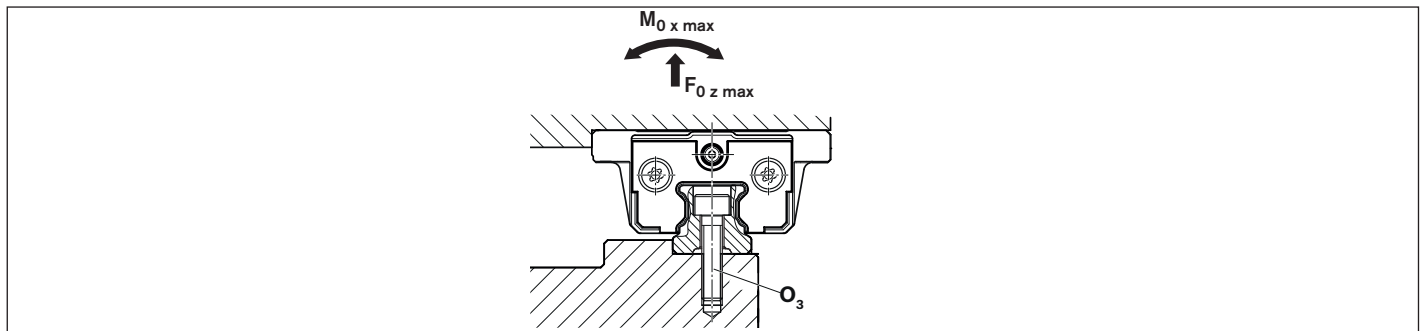

Tensile forces

Size	Maximum static tensile forces $F_{0z \max}$ in [N]					
	Normal length			Long		
	xNx			xLx		
	8.8	10.9	12.9	8.8	10.9	12.9
15	2,430	3,930	4,730	2,430	3,930	4,730
20	4,250	6,740	8,060	4,640	7,350	8,790
25	6,160	9,670	11,500	8,200	12,900	15,400
30	11,800	18,200	21,600	13,200	20,400	24,200
35	11,700	18,000	21,400	15,400	23,800	28,200
45	28,900	36,000	36,000	36,700	45,700	45,700

Torsional moments

Size	Maximum static torsional moments $M_{0x \max}$ in [Nm]					
	Normal length			Long		
	xNx			xLx		
	8.8	10.9	12.9	8.8	10.9	12.9
15	16	26	32	16	26	32
20	39	62	74	43	68	81
25	63	99	120	84	130	160
30	150	230	280	170	260	310
35	180	280	330	240	370	440
45	610	770	770	780	970	970

Fastening

Maximum static side load without stop strips

For a secure structure, Rexroth recommends using stop strips on the Runner Block and Guide Rail. If stop strips are not used on the runner block or the rail, then if a load is applied in the transverse direction the guideway may slip. The clamping force on the screw connection is too low as soon as the side loads in the table are exceeded.

The table values are guidelines for the permissible static side loads $F_{0y \max}$ that are only applicable when the following conditions are met:

- Screw sizes, screw quantity and connecting dimensions as listed in the catalog
- Same fastening screw strength class for blocks and rails
- Steel adjacent structure
- No interaction with traction force F_z , torsional moments M_x or longitudinal moments M_y/M_z

If these conditions are not met, recalculate the screw connection in accordance with VDI 2230. If the applied loads are just below the limit values, Bosch Rexroth also recommends checking the screw connections.

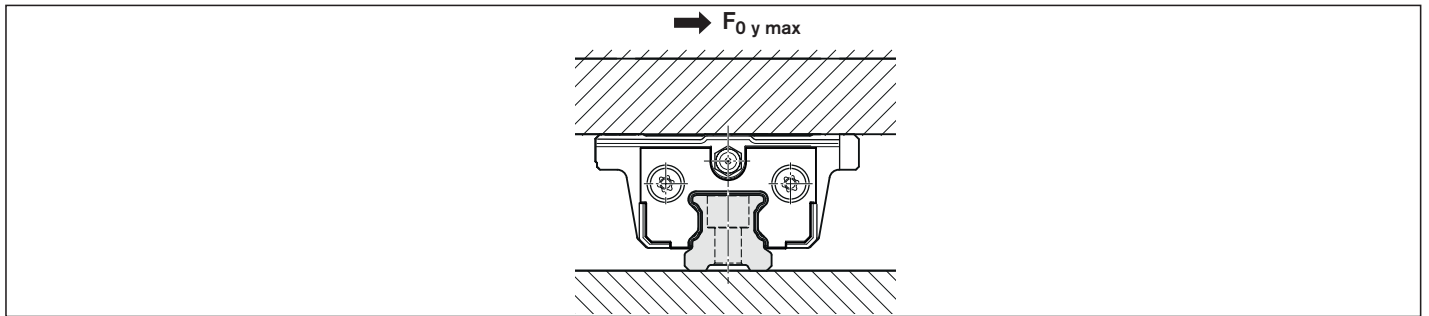

Lateral forces

Size	Maximum static lateral forces $F_{0y \max}$ in [N]					
	Normal length			Long		
	xNx			xLx		
	8.8	10.9	12.9	8.8	10.9	12.9
15	370	600	720	370	600	720
20	640	1,010	1,210	700	1,100	1,320
25	920	1,450	1,730	1,230	1,930	2,300
30	1,770	2,730	3,250	1,980	3,060	3,640
35	1,790	2,750	3,260	2,360	3,630	4,310
45	4,290	5,340	5,340	5,440	6,780	6,780

Fastening

Locating pins

- ⚠ If the guideline values for the permissible lateral force are exceeded (see the corresponding ball runner blocks), you must fix them additionally by pinning.

For the recommended dimensions for pin holes, refer to the dimension drawing and the dimensions.

Possible pin types

- ▶ Tapered pin (hardened) or
- ▶ Straight pin DIN ISO 8734

Note

- ▶ At the recommended positions for pin holes, there may be pre-drilled holes in the middle of the ball runner block due to production-related issues ($\varnothing < S_{10}$). They are suitable for drilling out.
- ▶ If it is necessary to carry out pinning at a different position (e.g. the middle lube connection), dimension E_2 must not be exceeded in the longitudinal direction (for dimension E_2 , refer to the dimension tables of the corresponding ball runner blocks). Comply with dimensions E_4 and E_5 !
- ▶ Do not complete the pin holes until after mounting.
- ▶ Please request the "Mounting Instructions for profiled rail systems".

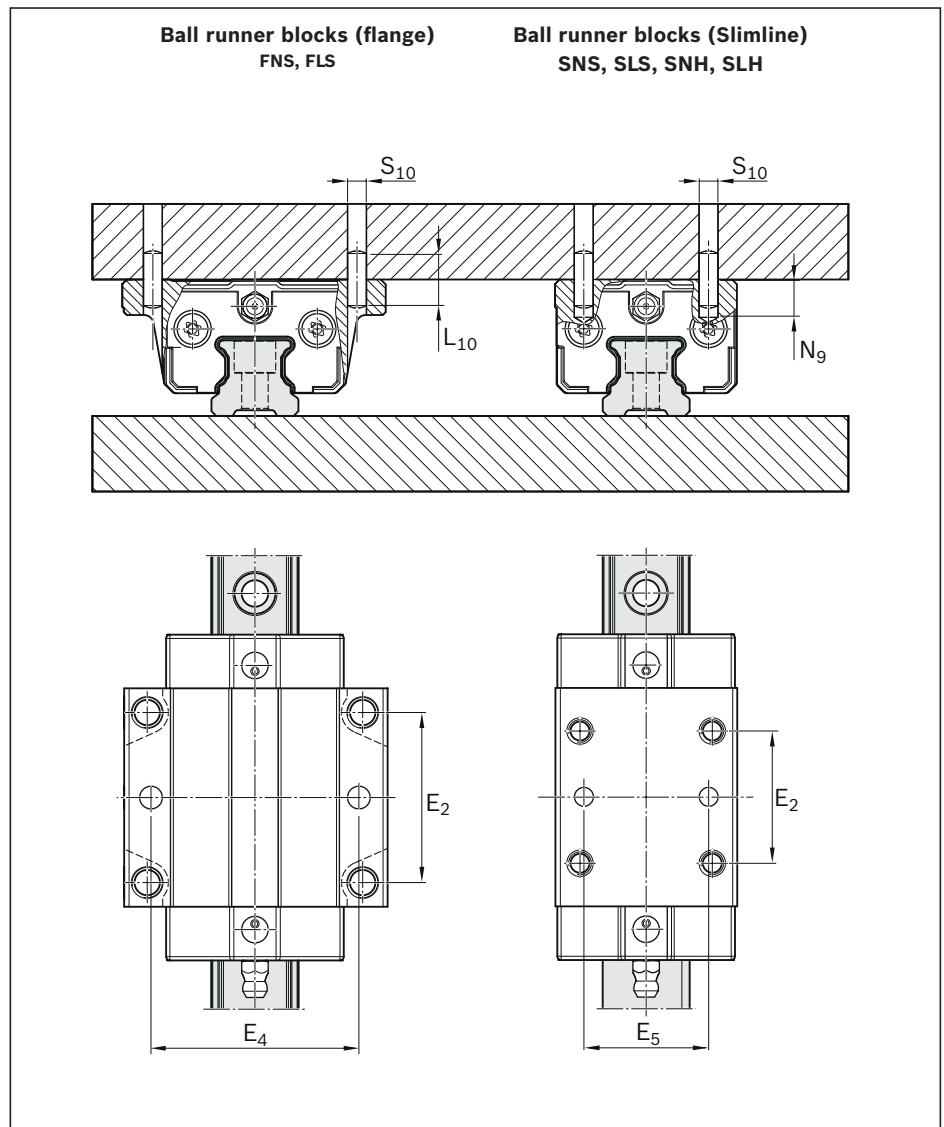

Size	Dimensions (mm)				
	E_4	E_5	$L_{10}^{1)}$	$N_{9 \max}$	$S_{10}^{1)}$
15	38	26	18	6.0	4
20	53	32	24	7.5	5
25	55	35	32	9.0	6
30	70	40	36	12.0	8
35	80	50	40	13.0	8
45	98	60	50	18.0	10

1) Tapered pin (hardened) or straight pin (DIN ISO 8734)

Fastening

Combination examples

The combinations shown here are examples. Basically, any ball runner block may be combined with any of the ball guide rail types offered.

Ball guide rail with ball runner block

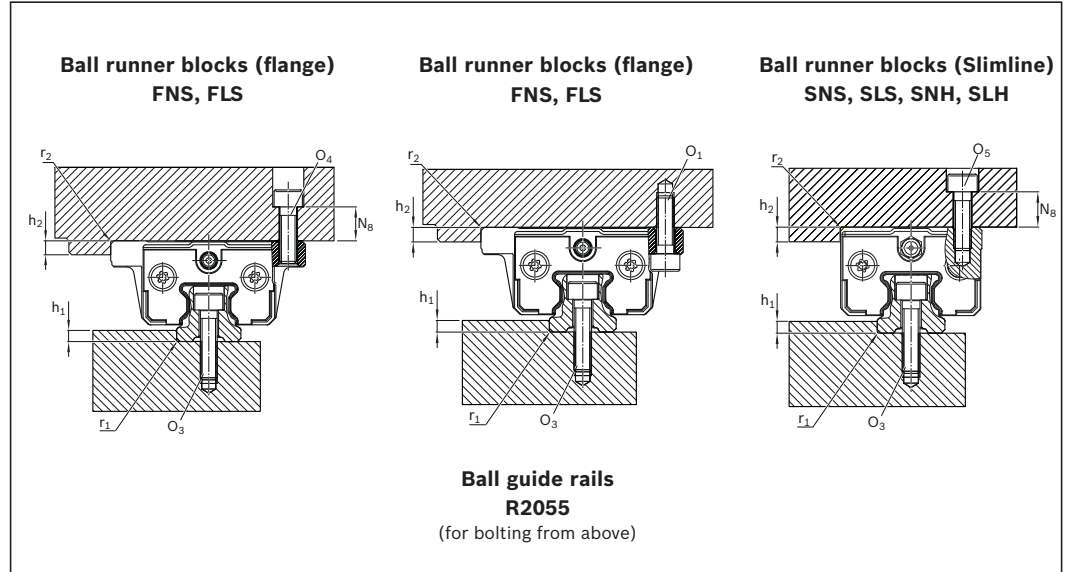

Size	Dimensions (mm)					
	$h_{1 \text{ min}}$	$h_{1 \text{ max}}$	h_2	N_8	$r_{1 \text{ max}}$	$r_{2 \text{ max}}$
15	2.5	3.5	4	6	0.4	0.6
20	2.5	4.0	5	9	0.6	0.6
25	3.0	5.0	5	10	0.8	0.8
30	3.0	5.0	6	10	0.8	0.8
35	3.5	6.0	6	13	0.8	0.8
45	4.5	8.0	8	14	0.8	0.8

Fastening screws

⚠ Always make sure the screws are secure where there are high screw loads!

For more information on this topic, see the section "General instructions for mounting".

Size	Screw sizes			
	Ball runner blocks			Ball guide rail
	O_1	O_4	O_5	O_3
	ISO 4762 4 pieces	ISO 4762 4 pieces	ISO 4762 4 pieces	ISO 4762
15	M4x12	M5x12	M4x12	M4x20
20	M5x16	M6x16	M5x16	M5x25
25	M6x20	M8x20	M6x18	M6x30
30	M8x25	M10x20	M8x20	M8x30
35	M8x25	M10x25	M8x25	M8x35
45	M10x30	M12x30	M10x30	M12x45

Notes on lubrication

The service life of the ball rail system crucially depends on the lubrication. For this purpose, the documentation, especially the chapter "Lubrication", must be read and understood completely.

All specifications on lubrication are based on experimental values and field experience are recommendations by Bosch Rexroth.

- ▶ For recommended lubricants, see the chapter "Lubricants".

⚠ If using a progressive lubrication system, with grease lubrication, please pay attention to the minimum dosing amount for relubrication stated in table 2.

The operator is responsible for the selection and adequate supply of an appropriate lubricant to the ball rail system. These notes do not exempt the operator from the individual examination of the conformity and suitability of the lubricant for its application.

⚠ To safeguard the supply of lubricant the lube fittings from the chapter "Accessories" must be used. When using other lube fittings it must be ensured that they are identical to Rexroth lube fittings.

Lubricants

(see chapter "Lubricants")

- ▶ Grease (NLGI 02)
- ▶ Liquid grease (NLGI 00)
- ▶ Oil (ISO VG 220)

Connecting elements

(see chapter "Accessories for ball runner blocks")

- ▶ Lube nipple
- ▶ Straight connectors
- ▶ Tube fittings
- ▶ O-rings, lubrication adapters (lube connection above)

Injection

- ▶ Manually (grease gun)
- ▶ Progressive lubrication system
- ▶ Single-line piston distributor systems
- ▶ Lubrication with front lube unit

Lubrication quantities, intervals, instructions

- ▶ Initial lubrication and relubrication (see chapter "Initial lubrication and relubrication")
- ▶ Relubrication intervals (see chapter "Relubrication intervals").
- ▶ Minimum dosing amounts (see chapter "Minimum dosing amount")
- ▶ Lubrication cycle configuration (see chapter "Lubrication with central lubrication systems")

Lube fittings

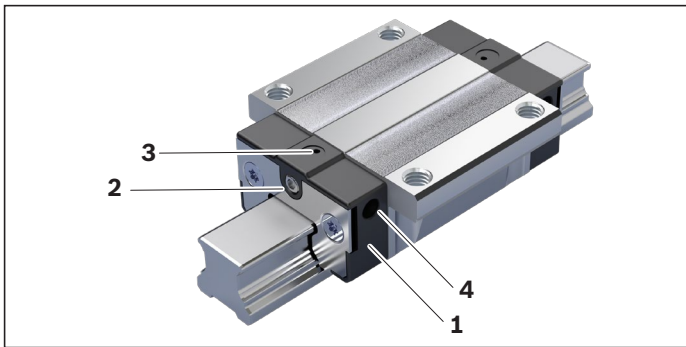

BSCL ball runner blocks feature four connection possibilities per end cap, through which a lubricant can be applied. Via the integrated channels in the end caps, the lubricant is evenly distributed among the four ball track turns.

- 1) End caps (2x)
- 2) Front lube connection
- 3) Top lube connection
- 4) Side lube connection (2x per end cap)

Lube connection selection

For standard stroke (stroke > 2 x ball runner block length B_1)

Lubrication at one of the two end caps is sufficient. For a vertical or sloping installation position, lubrication must be done via the higher-lying end cap using liquid grease or oil.

For short stroke (stroke < 2 x ball runner block length B_1)

Lubrication via both end caps is required.

Starting up lube fittings

Front lube connection:

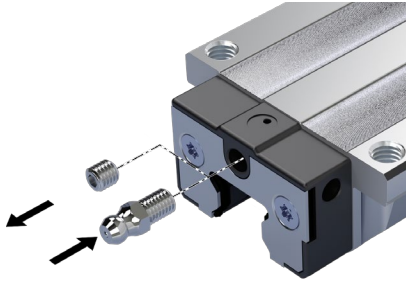

1. Screw out the set screw.
2. Screw in the lubricating element vertically.

Side lube fitting (2x):



1. Heat the metal tip (\varnothing 0.8 mm).
2. Pierce the plastic of the pilot hole carefully with a hot metal tip. Maximum permissible penetration: 1mm.
3. Screw in lubricating element vertically, if necessary, pre-cut thread with screw or tap.

Top lube connection:

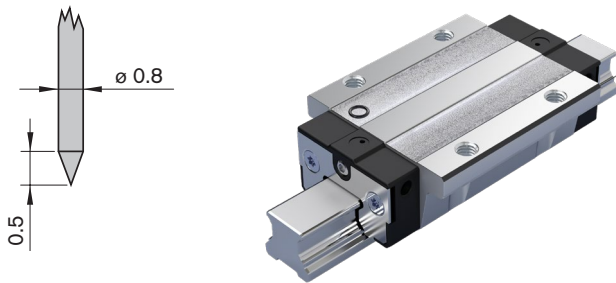

1. Heat the metal tip (\varnothing 0.8 mm).
 2. Pierce the plastic of the pilot hole carefully with a hot metal tip. Maximum permissible penetration: 1mm.
 3. Place the O-ring into the recess.
- (O-ring not included in the scope of delivery of the ball runner block, see Accessories for ball runner blocks).

Top lube connection, high runner block:

Use a lubrication adapter

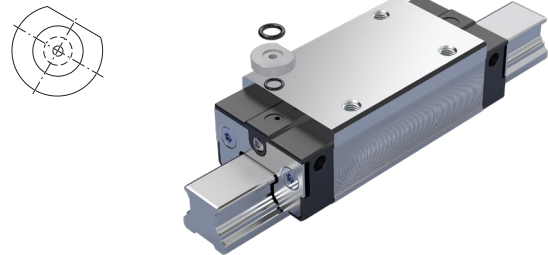

1. Open lube connection (as with lube connection above).
2. Place the O-ring into the recess.
3. Insert the lubrication adapter at a slant into the recess and press the straight side against the steel part. Use grease to fix the adapter in place.
4. Place the O-ring into the lubrication adapter. (O-rings are included with the lubrication adapter).

Notes:

- ▶ Alternatively, it is possible to open the side and top lube fittings with a 0.8 or 1.0 mm \varnothing twist drill. Pay attention to the maximum drilling depth of 1mm. Make sure that no shavings enter into the lubrication channel.
 - ▶ Only one lube connection may be used for each end cap.
 - ▶ Maximum lube pressure 30 bar, press slowly when lubricating with hand-operated grease gun.
 - ▶ For a selection of possible lubrication elements, see chapter "Accessories for ball runner blocks".
- You can also get in touch with the manufacturer of the lubrication system.

Lubricants

BSCL ball runner blocks can be lubricated with grease, liquid grease or oil:

	Grease (NLGI 2)	Liquid grease (NLGI 00)	Oil (ISO VG 220)
Injection	<ul style="list-style-type: none"> ▶Grease gun ▶Progressive lubrication system 	<ul style="list-style-type: none"> ▶Single-line piston distributor systems ▶Progressive lubrication system 	<ul style="list-style-type: none"> ▶Single-line piston distributor systems ▶Progressive lubrication system
Recommendation	Elkalub GLS 135/N2* <ul style="list-style-type: none"> ▶Grade NLGI 2 lithium-based high-performance grease according to DIN 51818 (KP2K-20 according to DIN 51825) ▶Good water resistance ▶Corrosion protection ▶Temperature range: -20 to +80 °C 	Elkalub GLS 135/N00* <ul style="list-style-type: none"> ▶Lithium-based, high-performance grease, Grade NLGI 00 according to DIN 51818 (GP00K-20 according to DIN 51826) ▶Good water resistance ▶Corrosion protection ▶Temperature range: -20 to +80 °C 	Shell Tonna S3 M 220 <ul style="list-style-type: none"> ▶Demulsifying special oil for bed tracks and machine tool guide rails, (CLP according to DIN 51517-3, VG 220 according to ISO 3448) ▶A blend of highly refined mineral base oils and additives ▶Can be used even when mixed with significant quantities of metalworking fluids
Approved alternative products	<ul style="list-style-type: none"> ▶Dynalub 510 ▶Castrol Tribol GR 100-2PD* 	<ul style="list-style-type: none"> ▶Dynalub 520 ▶Castrol Tribol GR 100-00PD* 	<ul style="list-style-type: none"> ▶Mobil Vactra Oil No. 4*

*) No liability is accepted for changes to the product properties of these lubricants.

Table 1

Notes on Dynalub

(Approved for EU countries only; not approved outside of the EU)

Under conventional environmental conditions, this short-fibred, homogeneous grease is ideally suited for the lubrication of linear elements:

- ▶ With loads up to 50 % C
- ▶ With short-stroke applications > 1 mm
- ▶ For the permissible travel speed range of ball rail systems

The product and safety data sheets can be found on our website at: www.boschrexroth.com.

⚠ If using different lubricants than the ones specified, relubrication intervals may be shorter and performance may decrease with short stroke and load ratio; in addition, chemical interactions can take place between the plastics, lubricants and preservative agents. Single-line central lubrication systems also need to be able to pump these lubricants.

⚠ Do not use lubricants with solid particles (e.g. graphite or MoS₂).

▶ Please consult us if the application involves special environmental requirements (such as clean room, vacuum, food industry applications, increased exposure to fluids or aggressive media, extreme temperatures).

Each application must be considered on its own merits in order to choose the most appropriate lubricant.

Special requirements call for special seals and wipers (see chapter "Ball runner block accessories").

Be sure to have all the information concerning your application at hand when contacting us.

Pay attention to the chapter "Maintenance".

Initial lubrication and relubrication

The following procedure is valid regardless of the type of lubricant injection method used.

For lubrication with one-point lubrication systems, additional notes and the configuration of the lubrication cycle is described in the chapter "Lubrication with one-point lubrication systems". For each application of lubricant, pay attention to the minimum dosage from table 3.

⚠ Never put ball runner blocks into operation without basic lubrication. No initial lubrication is required if pre-lubricated at the factory. Ball rail systems are supplied with preservation.

⚠ Lubricant reservoirs should contain an agitator to ensure the lubricant can flow (avoids hardening in the reservoir).

▶ Refer to chapter "Ball runner block accessories" for a selection of possible lube ports (in this connection, contact the manufacturer of your lubrication system too).

Initial lubrication:

⚠ BSCL ball runner blocks are pre-lubricated by default. Initial lubrication (basic lubrication) is merely necessary for non-lubricated runner blocks (material number R205X XXX 24).

⚠ The seals on the ball runner block must be oiled or greased with the respective lubricant before being slid onto the guide rail.

1. Apply lubricant quantities in accordance with table 2, for short stroke, apply in both end caps
2. Move the ball runner block back and forth with three double strokes, stroke length > 3 x runner block length
3. Repeat steps 1 and 2 (lubrication with oil: repeat 1 x)
4. Check whether you can see a film of grease on the rail

Relubrication:

▶ When the relubrication interval as described in the chapter "Relubrication" has been reached, then relubrication is necessary.

⚠ In the case of relubrication, it is not possible to change from grease to oil lubrication.

⚠ In the case of environmental influences such as contamination, high temperatures, vibration, impact load, etc., we recommend shortening the relubrication intervals.

⚠ Even under normal operating conditions, the system must be relubricated at the latest after two years due to aging of the grease.

⚠ For lubrication via central lubrication systems, the lubrication cycle is determined according to the chapter "Lubrication with central lubrication systems".

1. Apply lubricant quantities in accordance with table 2, for short stroke, apply in both end caps
2. Move the ball runner block back and forth with three double strokes, stroke length > 3 x runner block length

Lubrication quantities

Size	Initial lubrication (cm ³) ¹⁾		Relubrication (cm ³)	
	Grease (NLGI2) Liquid grease (NLGI00)	Oil (ISO VG 220)	Grease (NLGI2) Liquid grease (NLGI00)	Oil (ISO VG 220)
15	0.4 (3x)	0.6 (2x)	0.4 (2x)	0.6
20	0.7 (3x)	1.0 (2x)	0.7 (2x)	1.0
25	1.4 (3x)	1.5 (2x)	1.4 (2x)	1.5
30	2.2 (3x)	1.6 (2x)	2.2 (2x)	1.6
35	2.2 (3x)	1.8 (2x)	2.2 (2x)	1.8
45	4.7 (3x)	3.0 (2x)	5.7 (2x)	3.0

Table 2

1) ⚠ No initial lubrication is required for runner blocks with pre-lubrication (R205X XXX 20).

⚠ Pay attention to the notes on lubrication !

Relubrication intervals

The relubrication of ball rail systems is load-dependent. With the load ratio F_m/C_{100} , the relubrication interval can be determined according to the diagrams (fig. 1-3). After this distance has been traveled, the ball runner block is to be relubricated (see chapter "Initial lubrication and relubrication").

The relubrication intervals were determined empirically under the following conditions:

- ▶ Observe load ratios F_m/C_{100}
- ▶ No exposure to metalworking fluids
- ▶ Ambient temperature:
T = 10 – 40 °C
- ▶ Lubricant recommended by Rexroth Recommendation

For deviant operating conditions, please ask, in particular in case of:

- ▶ Exposure to cooling lubricants
- ▶ Dust accumulation
(Wood, paper,...)
- ▶ Standard sealing (SS) in combination with front seal or seal kit
- ▶ at low mean travel speed v_m
- ▶ at a raised ambient temperature
- ▶ at high loads $F_m/C > 0.4$
- ▶ with short stroke

Key

- C_{100} = dynamic load capacity (N)
- F_m = dynamically equivalent load on bearing (N)
- F_m/C_{100} = load ratio (-)
- s = relubrication interval as travel distance (km)

⚠ Pay attention to the notes on lubrication !

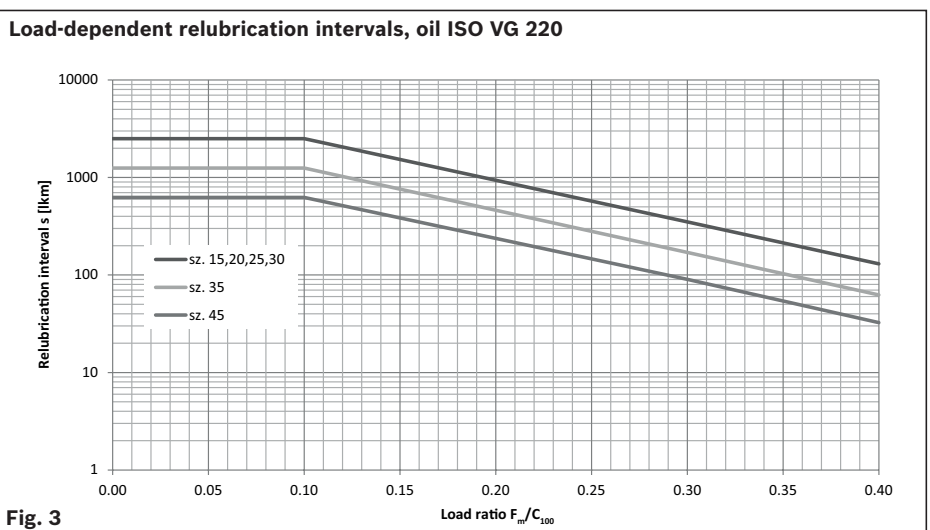
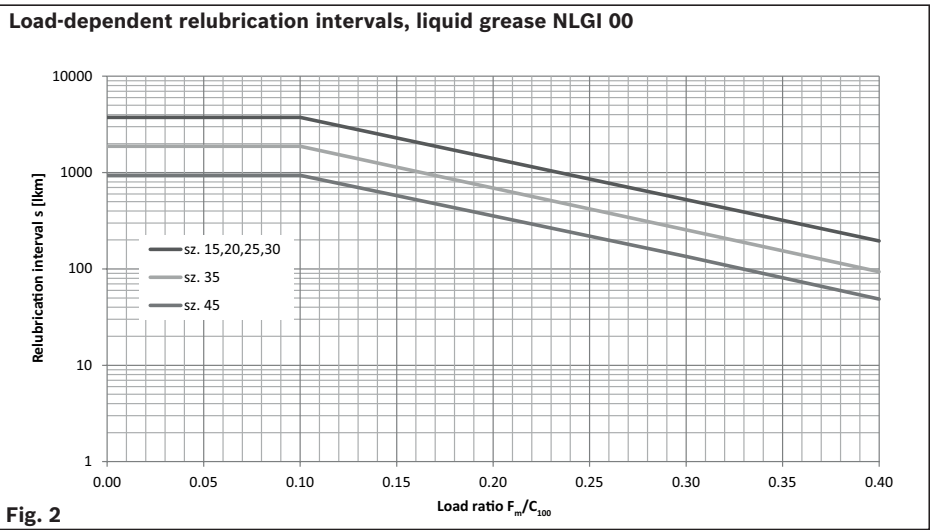
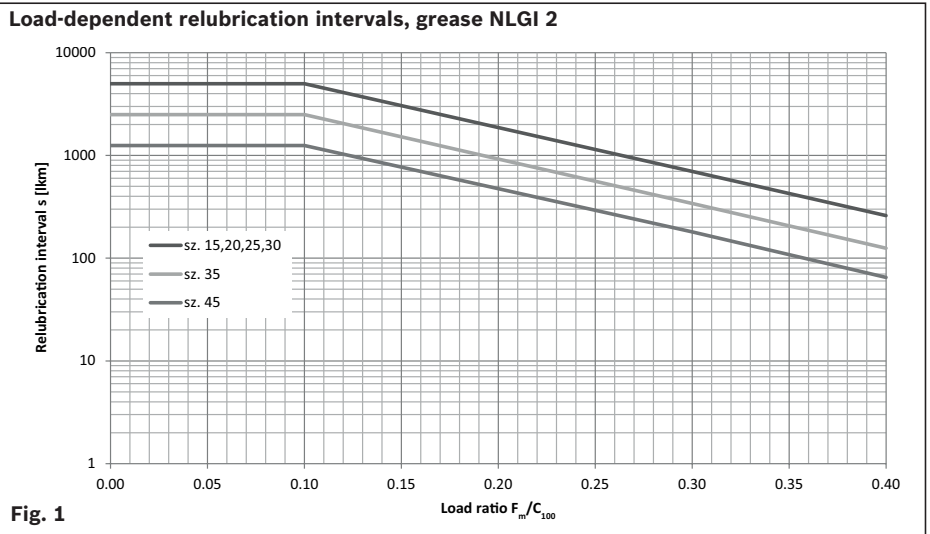

Minimum amount, minimum piston distributor size

To ensure a uniform lubricant distribution in the ball runner block, a minimum amount of lubricant as per table 3 must be applied during each lubrication session. This is mainly relevant for automatic lubrication via single-line piston distributor¹⁾ or progressive lubrication²⁾ systems. Applies to all installation positions. For short stroke, the amount per end cap indicated is valid.

Size	Grease (NLGI2) / liquid grease (NLGI00) (cm ³)	Oil (ISO VG 220) (cm ³)
15	0.3	0.4
20	0.3	0.6
25	0.3	0.6
30	0.3	0.6
35	0.3	0.6
45	0.3	1.0

Table 3

1) Liquid grease, oil

2) Grease, liquid grease, oil

Lubrication with central lubrication systems

There are two possibilities for supplying ball runner blocks with a central lubrication system:

- ▶ Lubrication with progressive lubrication system (grease, liquid grease, oil)
- ▶ Lubrication with single-line piston distributor systems (liquid grease, oil)

The following procedure applies when configuring the lubrication cycle for central lubrication systems:

Step	Calculation process	Example:
		BSCL ball runner block size 25 FNS Lubrication via single-line piston distributor system Oil (ISO VG 220) Load $F_m = 6,540 \text{ N}$
1. Determining the amount of lubricant	Table 2, chapter "Initial lubrication and relubrication"	Amount of lubricant size 25, oil: 1.5 cm^3
2. Determining the minimum piston distributor size / minimum lubricant amount	Table 3, chapter "Minimum amount, minimum piston distributor size"	Minimum amount of lubricant size 25, oil: 0.6 cm^3 ▶ Selected piston distributor: 0.6 cm^3
3. Calculation of the lubrication pulse rate for the application of the relubrication quantity	$\text{Pulse count } n = \frac{\text{Relubrication quantity (cm}^3\text{)}}{\text{Volume per lubrication pulse (cm}^3\text{)}}$ <p>Round up to next whole digit</p>	$n = \frac{1.5 \text{ cm}^3}{0.6 \text{ cm}^3} = 2.5$ <p>▶ For relubrication to inject the proper amount 3 lubrication pulses are needed.</p>
4. Determining the relubrication interval from chapter "Relubrication intervals"	$\text{Load ratio } L = \frac{\text{Dyn. equivalent bearing load (N)}}{\text{Dyn. load capacity (N)}}$ $L = \frac{F_m}{C_{100}}$	$\text{Load ratio } L = \frac{6,540 \text{ N}}{21,800 \text{ N}} \approx 0.30$ <p>Relubrication interval: 350 km (fig. 3) ▶ For relubrication purposes, 1.5 cm^3 of lubricant must be injected after 350 km.</p>
5. Calculating the lubrication cycle	$\text{Lubrication cycle} = \frac{\text{Relubrication interval (km)}}{\text{Number of pulses}}$	$\text{Lubrication cycle} = \frac{350 \text{ km}}{3} = 116 \text{ km}$ <p>A minimum quantity of 0.6 cm^3 lubricant oil must be supplied per ball runner blocks (with short-stroke application per end cap) at the latest after a travel distance of 116 km.</p>

Notes:

- ⚠ We recommend carrying out initial lubrication manually before connecting to the central lubrication system.
- ⚠ All lines and elements must be filled with lubricant to the connection to the ball runner blocks and must not contain air pockets.
- ⚠ Pumping or storage tanks for the lubricant should be fitted with a stirrer or follower piston to guarantee the flow (to avoid funneling in the tank).
- ⚠ When applying metalworking fluids at the start or after a relatively long standstill, carry out 2 to 5 lubrication pulses in succession. When the system is in operation, 3 to 4 pulses per hour are recommended, irrespective of the distance traveled. If possible, carry out lubrication in one lubricating stroke. Carry out cleaning cycles (see "Maintenance"). The user alone is responsible for selecting suitable metalworking fluids. An unfavorable selection of coolant/lubricant may lead to damage to the ball rail system. We recommend getting in touch with the manufacturer of the coolant/lubricant. Bosch Rexroth accepts no liability. Lubricant and metalworking fluids must be coordinated.
- ▶ Rexroth recommends piston distributors manufactured by SKF. These should be installed as close as possible to the lube fittings of the ball runner blocks. Long lines and small line diameters should be avoided, and the lines should be laid on an upward slant. Install the lines at a gradient.
- ▶ If other consumers are connected to the central lubrication system, the weakest link in the chain will determine the lubrication cycle time.

Maintenance

Cleaning cycle

Dirt can settle and encrust on ball guide rails, especially when these are not enclosed. To ensure that seals and wipers retain their functionality, this dirt must be removed at regular intervals. It is advisable to perform at least one full cleaning cycle over the entire installed rail length every eight hours. In case of contamination or the use of a cooling lubricant, a shorter interval is recommended.

Before shutting down the machine, always perform a few lubricating pulses or lubricating strokes one after another. The lubrication pulses should take place over the maximum possible travel distance (cleaning cycle) while the axis is motion.

Maintenance

All elements used for scraping or wiping the ball guide rails must be cleaned and lubricated at regular intervals.

We recommend annual maintenance.

Further information

You can find extensive information here on products as well as training and service offers.

Homepage Bosch Rexroth Linear Motion Technology

<https://www.boschrexroth.com/web/a74aa994-0afe-4a3b-9e3f-3e615572d31a>

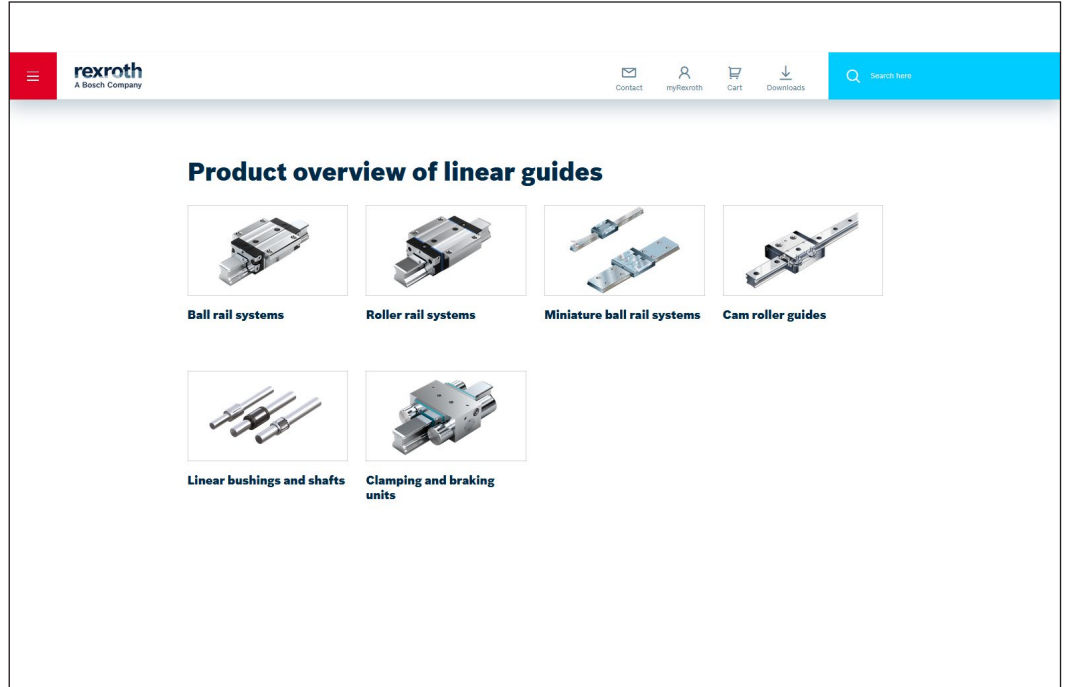

Calculation program Linear Motion Designer

www.boschrexroth.com/lmd

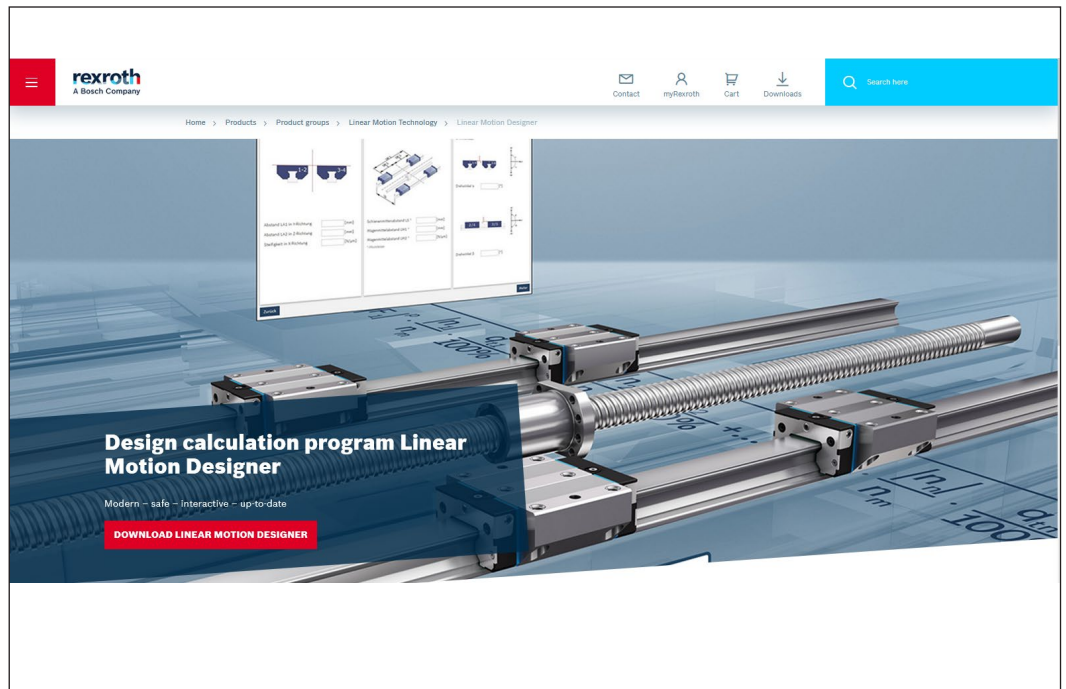

Service

<https://www.boschrexroth.com/de/de/service/>

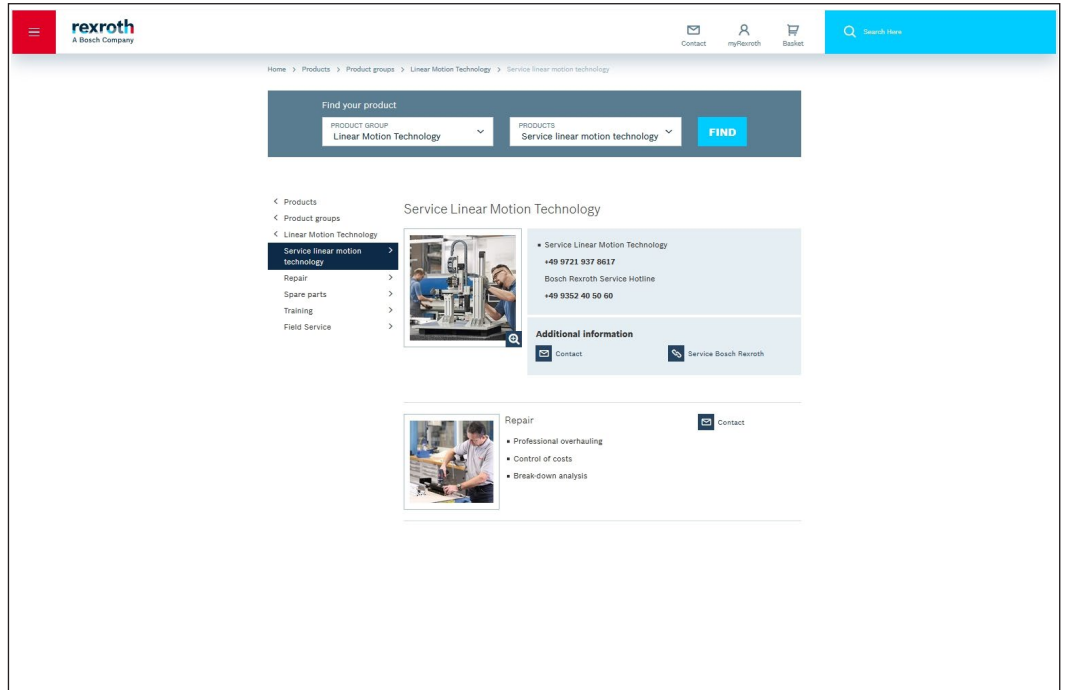

Rexroth Store

<https://store.boschrexroth.com/>

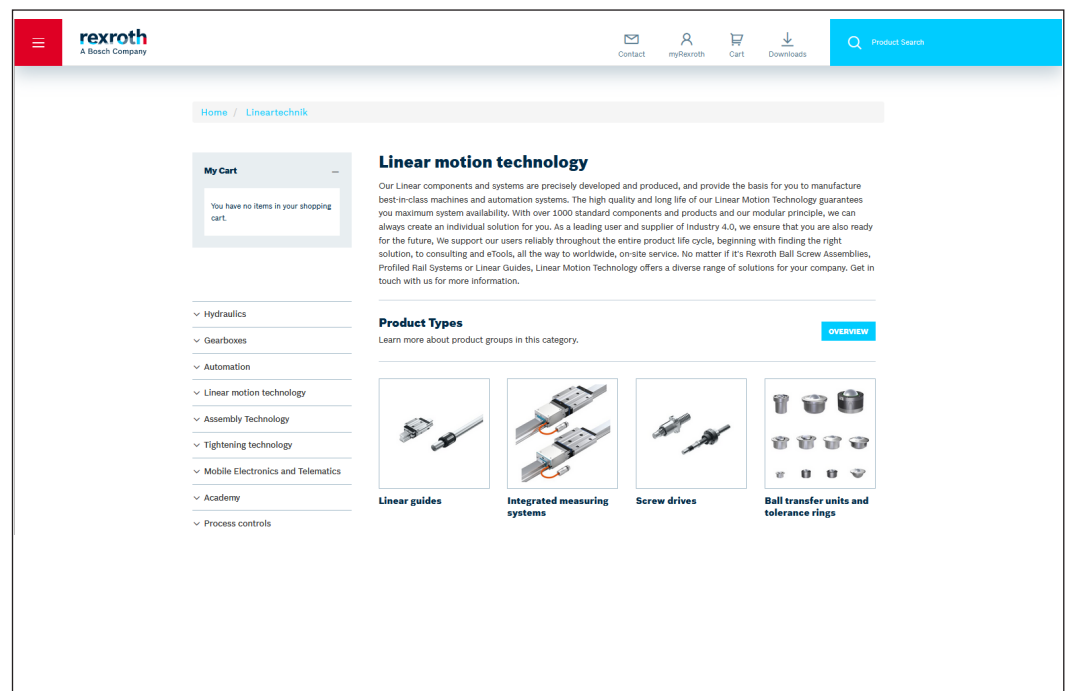

How-to: Linear Motion Technology

<https://www.youtube.com/playlist?list=PLRO3LeFQeLyNYHTIzi-PeoiuRTpNREvVZ>

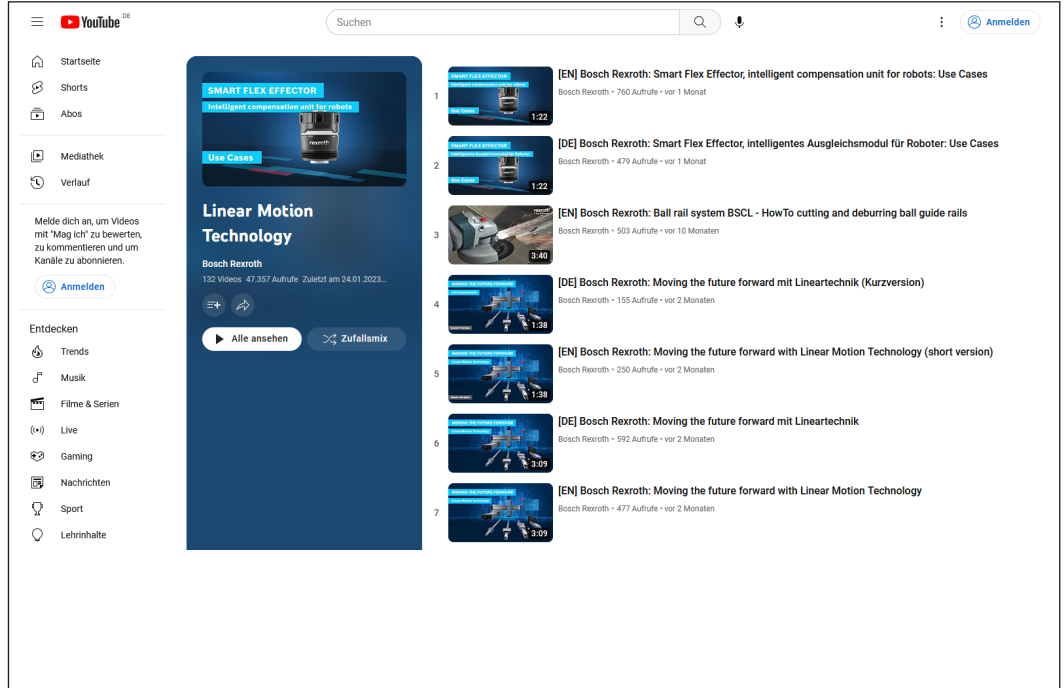

The screenshot shows a YouTube playlist page for 'Linear Motion Technology' by Bosch Rexroth. The main video featured is 'SMART FLEX EFFECTOR' with the subtitle 'Intelligent compensation unit for robots: Use Cases'. Below it, a list of seven videos is shown, including 'Ball rail system BSCL - HowTo cutting and deburring ball guide rails' and several 'Moving the future forward with Linear Motion Technology' videos in both English and German.

Academy

<https://www.boschrexroth.com/academy/>

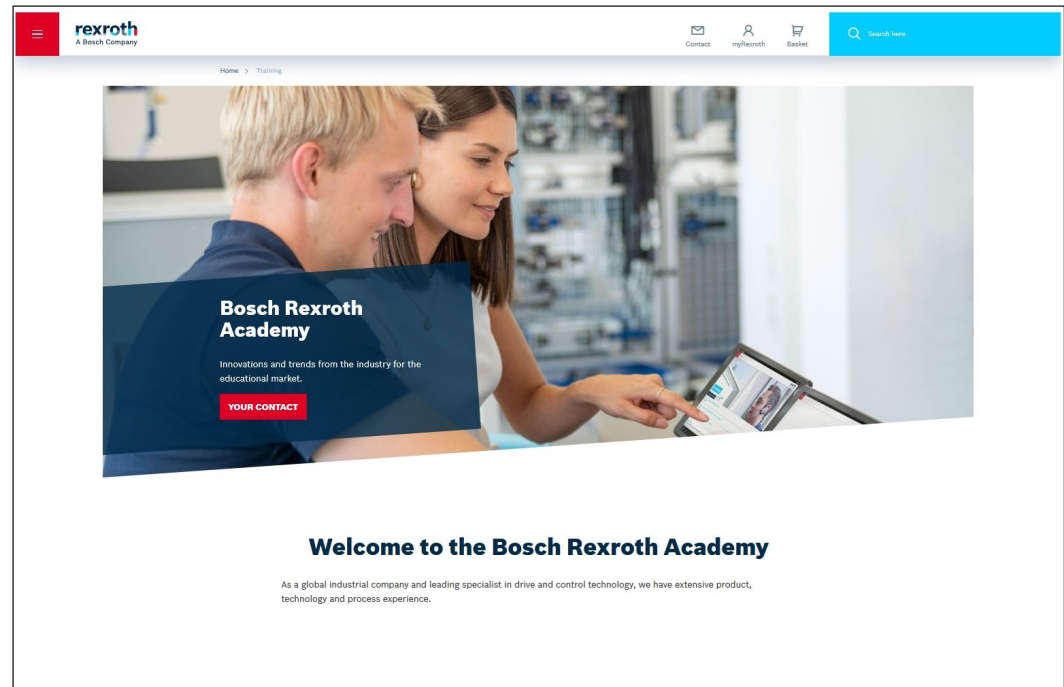

The screenshot displays the Bosch Rexroth Academy website. The header includes the company logo and navigation options like 'Contact', 'myrexroth', and 'Basket'. The main content area features a large image of a man and a woman in a professional setting, with the text 'Bosch Rexroth Academy' and 'Innovations and trends from the industry for the educational market.' A red button labeled 'YOUR CONTACT' is visible. Below the image, a welcome message reads: 'Welcome to the Bosch Rexroth Academy. As a global industrial company and leading specialist in drive and control technology, we have extensive product, technology and process experience.'

Bosch Rexroth AG

Ernst-Sachs-Straße 100
97424 Schweinfurt, Germany
Tel. +49 9721 937-0
Fax +49 9721 937-275
www.boschrexroth.com

Find your local contact person here:

www.boschrexroth.com/contact

The data specified above only serves to describe the product.

Due to the continuing development of our products, no statements concerning a certain condition or suitability for a certain application can be derived from our information. The information given does not release the user from the obligation of their own judgment and verification. Our products are subject to natural wear and aging.