

Smart Function Kit

for pressing and joining applications

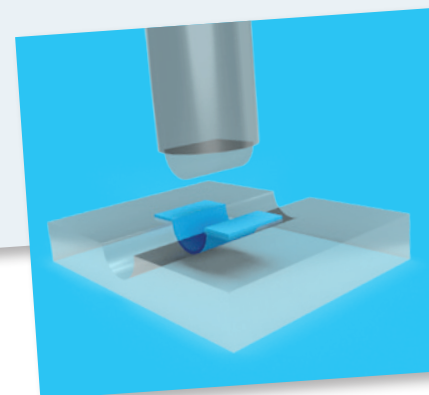
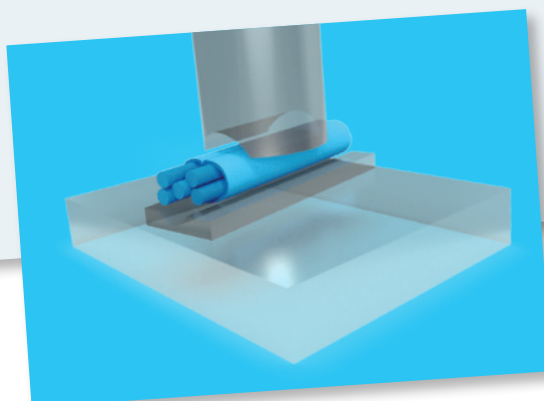
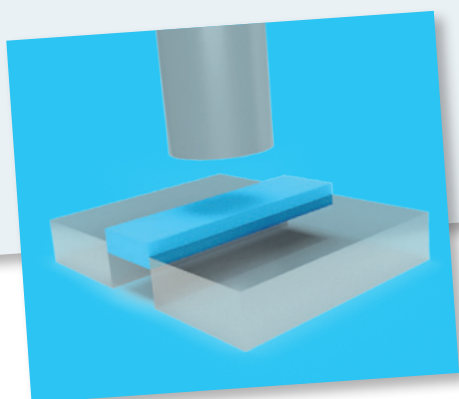
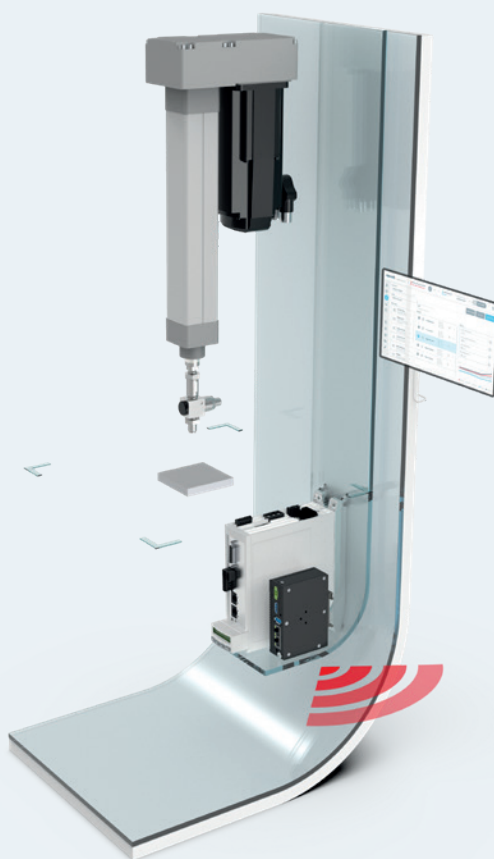

www.boschrexroth.com

Contents

Product description	4
Hardware	5
Software	6
Technical data	8
General information	8
Hardware	8
Electromechanical cylinder EMC	8
IndraDyn S - MS2N servo motors	12
HCS01 drive controller	14
HSZ01 safety zone module	15
PR21 industrial PC	16
Force sensor	18
Accessories	20
Software	21
General information	21
Dashboard	22
Sequence creation	22
Process and data	23
Reference curves and curve evaluation	23
Interfaces	24
Configuration and CAD data	25
Ordering code	26
Additional documentation	27

Product description

The Smart Function Kit mechatronic building system is suitable for numerous pressing and joining applications.

- ▶ Observe the safety instructions in the manual R320103194.

The web-based software allows for both easy creation of a sequence by means of drag & drop of sequential modules and for the recording of the force/path development and its subsequent evaluation (OK/NOK) by envelopes, windows and limit values.

The Smart Function Kit is thus an ideal basis for system integrators and end users and can be used as a stand-alone solution or incorporated into higher-level systems via field bus and/or OPC UA.

- ▶ System kit for force range of up to 70 kN for mounting and joining processes, forming technology and test applications
- ▶ Pre-selected kits consisting of cylinder mechanics, drive controllers with integrated control and web-based operating software for easy and quick creation and evaluation of process sequences
- ▶ Easy start-up using the pre-installed software and automatic drive parameterization
- ▶ Open interfaces for connection to higher-level controllers and data exchange via OPC-UA or the ReST API
- ▶ Optimum price/performance ratio

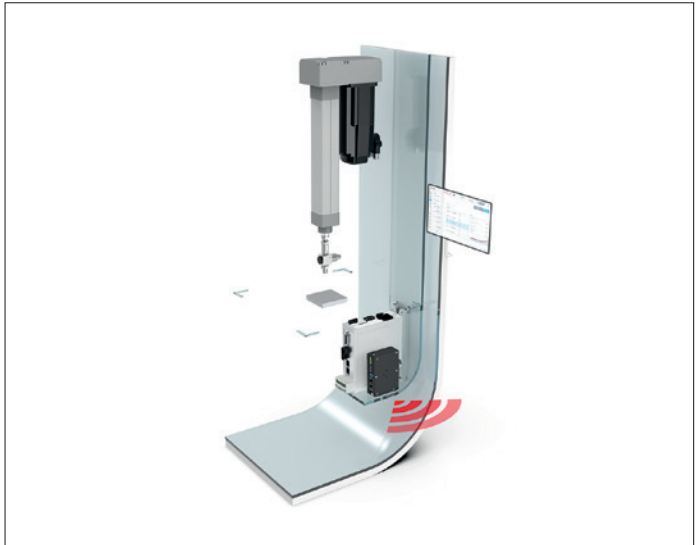

Areas of application

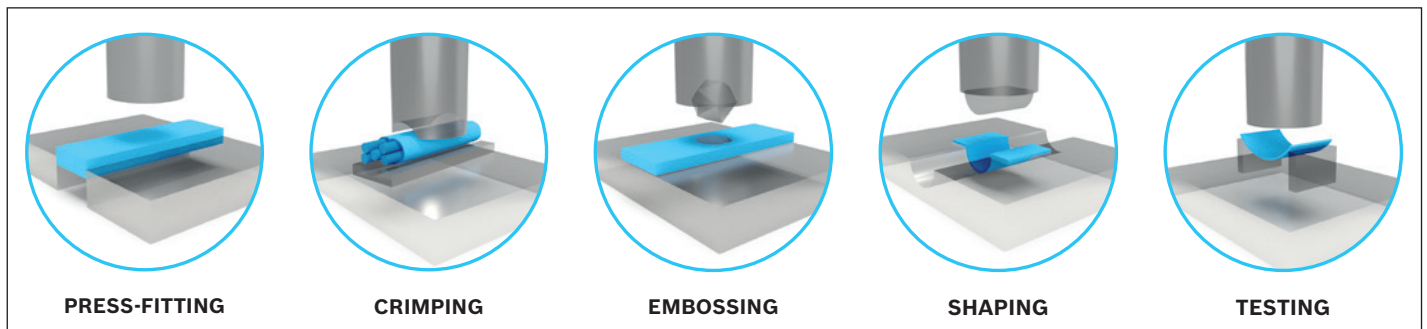

Notes

- ▶ The SFK software does not require any programming knowledge. Only communication with higher-level control systems requires corresponding knowledge (definition of data transfer and bus interfaces and digital inputs and outputs). Suitable field bus sample projects are provided in the SFK software.
- ▶ Process data can be displayed live in the HMI. After the end of the program, they are available for further processing in JSON format.

Hardware

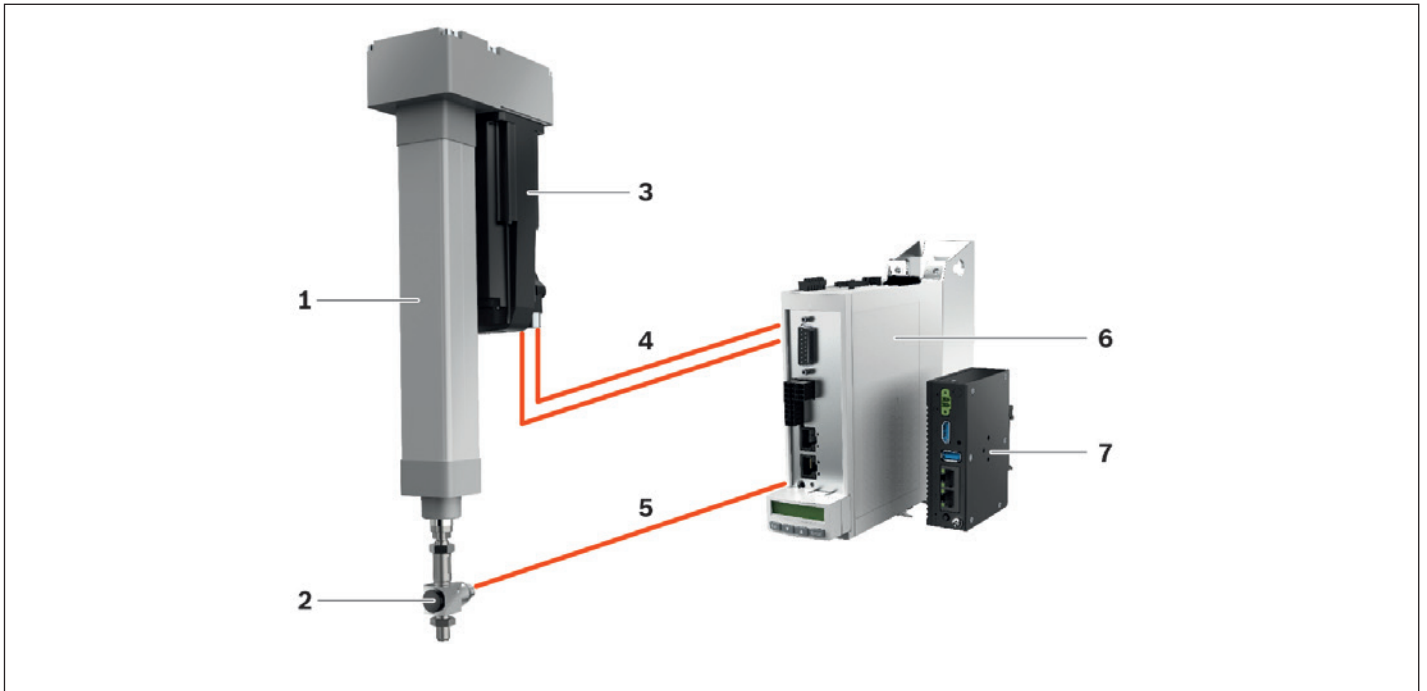

- 1 Electromechanical cylinder EMC** with freely configurable travel up to 400 mm (longer travel ranges upon request). Parallel or axial motor attachment
- 2 Force sensor:** DMS technology for cost-effective and robust force measurement
- 3 MS2N servo motor:** with absolute encoder and holding brake
- 4 Motor cable**
- 5 Sensor cable**
- 6 IndraDrive HCS01 drive controller** with integrated PLC IndraMotion MLD and STO safety function and/or Safe Motion
- 7 Industrial PC PR21** with integrated web server for providing the web-based operating software, with Linux operating system

Software

Thanks to the modern, intuitive web HMIs with modular drag-and-drop process configuration, the software is ready for immediate use, with no previous knowledge required. The straightforward process for the visual generation of all required assessment and analysis elements is practically self-explanatory.

Commissioning with auto configuration

- ▶ Preinstalled software
- ▶ Wizard for easy, fast commissioning
- ▶ Auto parameterization of the drive controller
- ▶ Support for commissioning with reference run and jog mode

Simple programming and operation

- ▶ Modular process configuration with drag and drop
- ▶ Logic check of input data
- ▶ Process optimization supported by a control bar with current process values
- ▶ Simple visual definition of evaluation and analysis elements
- ▶ Visualization of process and status information in the dashboard
- ▶ Field bus sample projects for the easy integration into higher-level control systems

Analysis and diagnosis via dashboard and logbook

- ▶ Live display of the sequence and the force/path curves
- ▶ Visualization of the process result (OK/NOK)
- ▶ Storing of process data for quality assurance in internal database
- ▶ Process history with filter and export function (export in JSON format)
- ▶ Diagnostic functions: System parameters as well as status reports and statistics
- ▶ Log book with plain text error messages integrated in the software
- ▶ Data access via ReST programming interface

Dashboard

The dashboard provides a compact overview of the system and production status. For this purpose, the four tiles contain information on production statistics, quality evaluation of the parts produced last, on the current program progress and the current machine values.

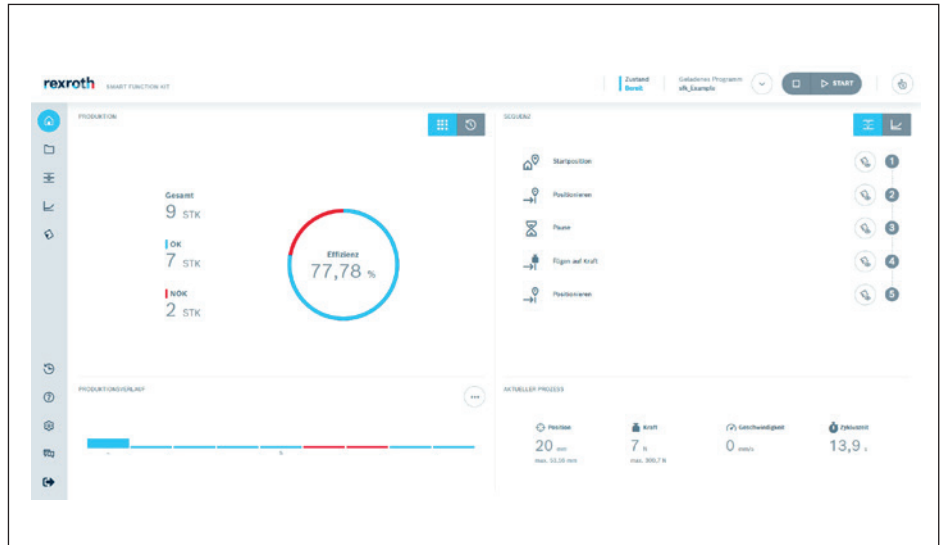

Program creation

The process is created by dragging & dropping sequential modules from the library. The selected modules can afterwards be individually parameterized.

For quick and easy process creation, the control bar can be displayed on the right side of any screen. It allows manual traversing, taring of the force sensor and shows current values for position, force and speed.

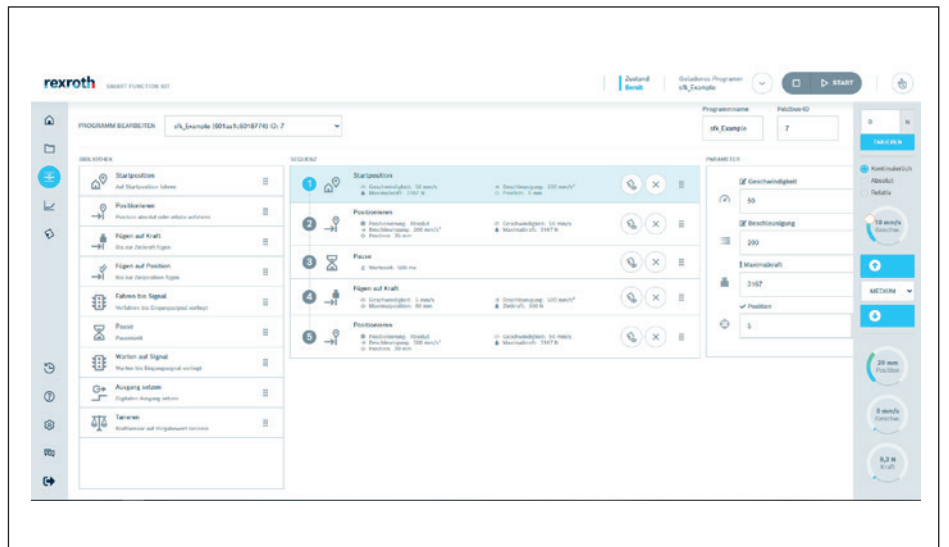

evaluation elements

In this area, you can individually define evaluation elements for every program in a graphical form. The elements are used for the automatic quality assessment and by means of their evaluation, the system determines whether a produced part is OK or NOK.

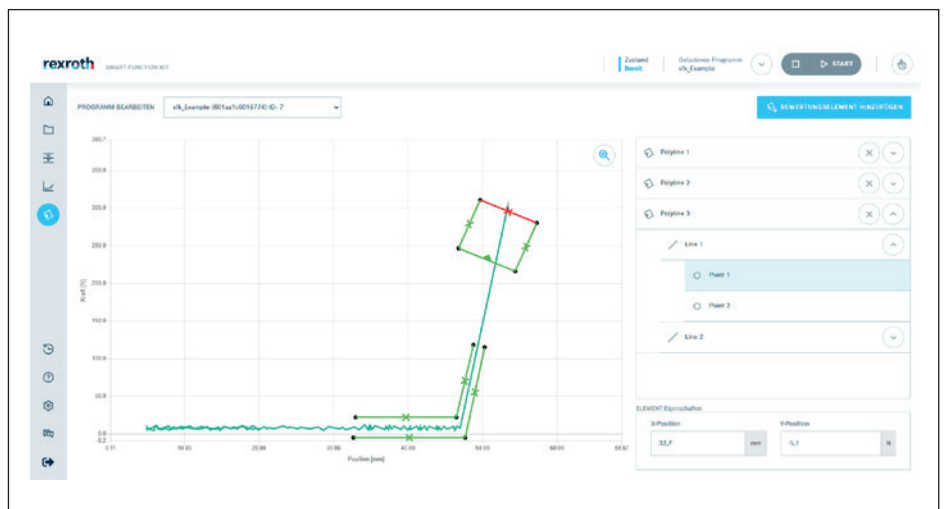

Technical data

General information

Smart Function Kit size		002	004	007	012	019	030	045	070
Travel path ¹⁾	mm	35 ... 400	40 ... 400	65 ... 400	80 ... 400	70 ... 400	90 ... 400	110 ... 400	130 ... 400
Nominal force	kN	2	4	7	12	19	30	45	70
Maximum force	kN	3	6	10	15	20	40	47	72
Max. speed ¹⁾	m/s	0.38	0.32	0.55	0.5	0.37	0.5	0.32	0.26 ²⁾ / 0.22 ³⁾
Repeatability	mm	up to ± 0.01							

¹⁾ Higher values possible on request

²⁾ Axial motor attachment

³⁾ Parallel motor attachment

Hardware

Electromechanical cylinder EMC

Smart Function Kit / size		002	004	007	012	019	030	045	070
EMC size		040-NN-2	050-NN-2	063-NN-2	080-NN-2	100-NN-2	100-XC-2	130-HP	160-HP
Screw lead	mm	5	5	10	10	10	10	5	5
Service life (on the basis of an internally defined reference cycle)		> 10 million cycles							
Relubrication interval in spindle revolutions	Million	50	50	50	50	50	10	16	8

Length calculation:

Overall length of EMC for motor attachment with flange and coupling = $L_{zs} + S_{max} + L_{ad} + L_f + L_m$

Overall length of EMC for motor attachment with belt side drive = $L_{zs} + S_{max} + L_{ad} + G$

(for L_f , L_m and G , see following page)

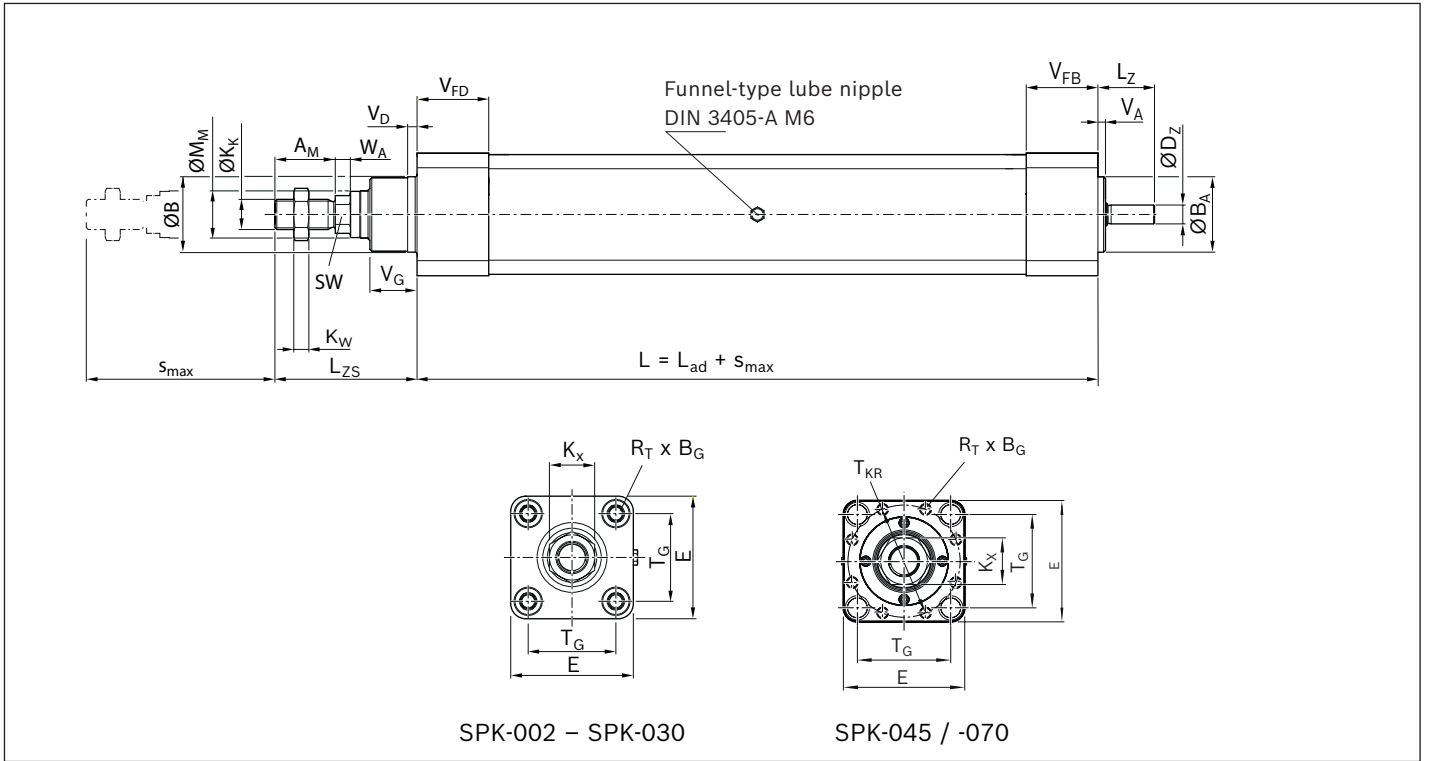

EMC / SPK	Rexroth ball screw assembly $d_0 \times P$	Dimensions (mm)								
		A_M -0.1	B_{d11} / B_A h7	D^Z h7	E ± 0.1	K_K	K_W	K_X	L_{ZS}	
040 / 002	16 x 5	24	35	8	53	M12 x 1.25	7	19	61.50	
050 / 004	20 x 5	32	40	10	65	M16 x 1.5	8	24	76.75	
063 / 007	25 x 10	32	45	15	75	M16 x 1.5	8	24	76.50	
080 / 012	32 x 10	40	55	18	95	M20 x 1.5	10	30	94.50	
100 / 019	40 x 10	40	65	25	115	M20 x 1.5	10	30	99.25	
100XC / 030	50 x 10	72	75	32	115	M36 x 2	18	55	144.00	
130-HP / 045	39 x 5	71	$\varnothing B: 95; \varnothing B_A: 80$	35	130	M33 x 2	26	50	155.00	
160-HP / 070	45 x 5 ¹⁾ / 45 x 10 ²⁾	89	$\varnothing B: 106; \varnothing B_A: 93$	40	160	M42 x 2	34	65	176.00	

EMC / SPK	Dimensions (mm)															
	L_{ad}	L_Z	$M_{M\ f8}$	R_T	B_G	$\varnothing T_{KR}$	R_L	SW	T_G	V_A ± 0.1	V_D	V_{FB}	V_{FD}	V_G ± 0.1	W_A	
040 / 002	134	25	20	M6	18		4	13	38.0	4	5	33	30	20	6	
050 / 004	142	30	25	M8	18		5	17	46.5			38	38	25	8	
063 / 007	148	35	30	M8	18		5	17	56.5			40	38	25	8	
080 / 012	163	46	38	M10	22		6	22	72.0			44	45	33	10	
100 / 019	171	57	50	M10	22		6	22	89.0			54	45	38	10	
100XC / 030	316	62	60	M12	28		7	36	89.0			121	62	38	18	
130-HP / 045	364	78	60	M12 (8x)	26	120	-	50	100.0			-	117.5	95.5	30	22
160-HP / 070	418.5	82	70	M14 (8x)	29	145	-	60	125.0	-	135	105.5	30	25		

1) Axial motor attachment
2) Parallel motor attachment

Motor attachment

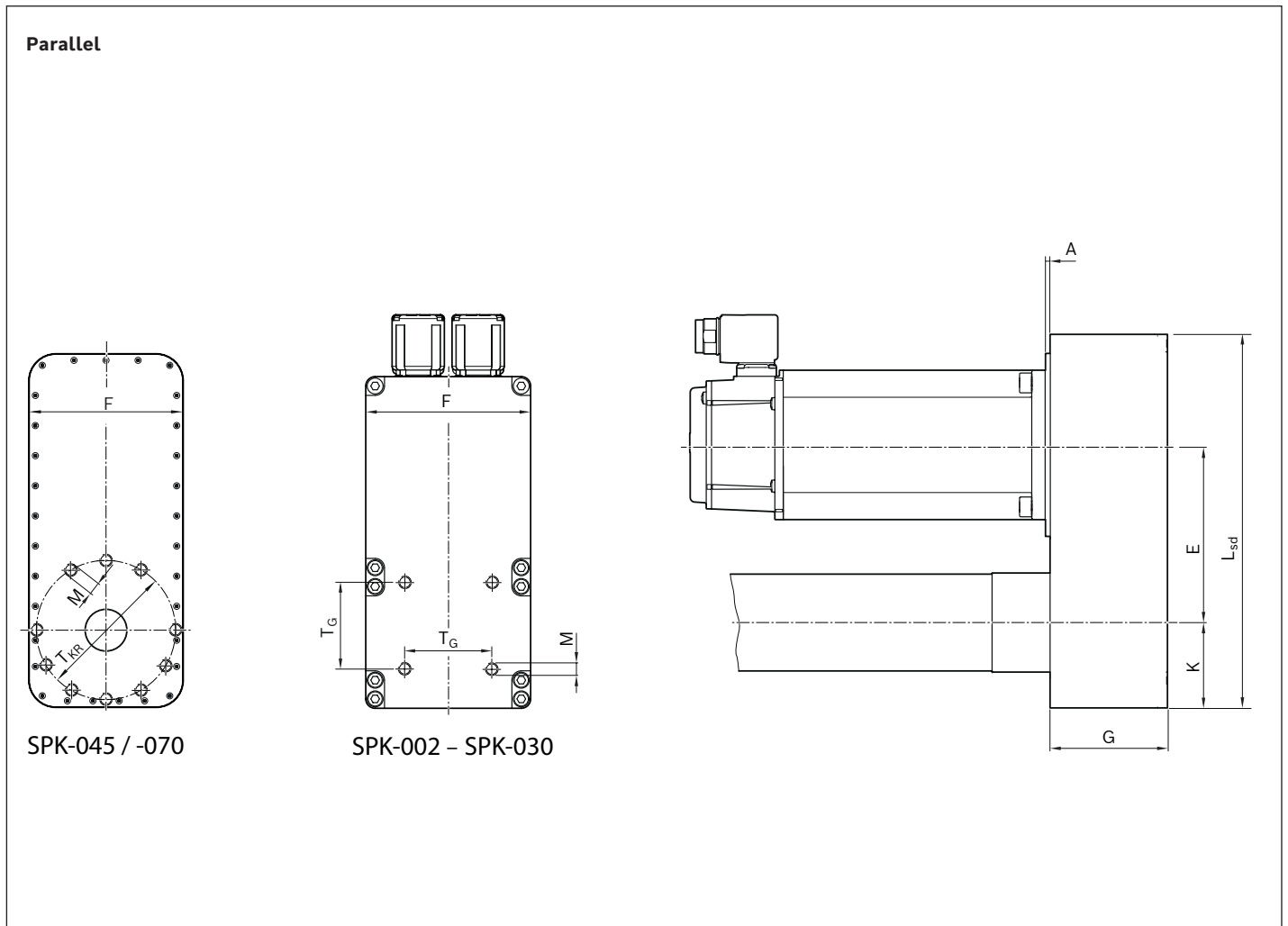
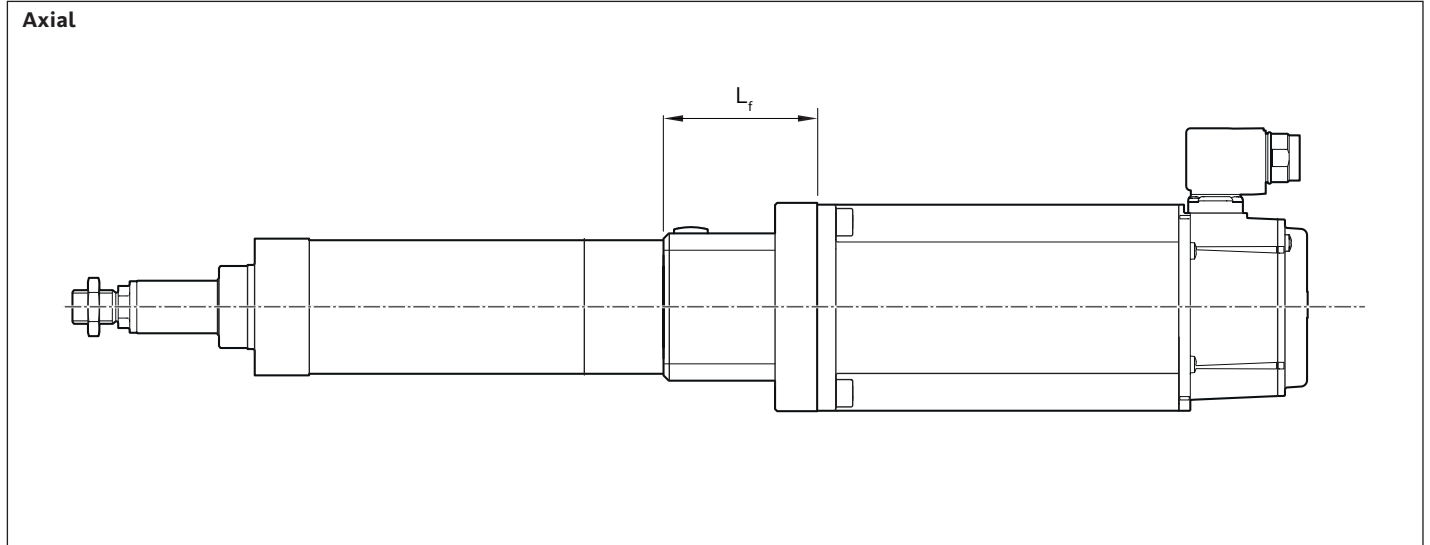

EMC SPK	For motor	i	Dimensions (mm)										
			A	E	F	G	K	L _f	L _{sd}	M	T _G	ØT _{KR}	Mt ¹⁾
040 002	MS2N04-B	1	–	82.2	88	55.5	44.0	61	177	M6	38.0	–	16.0
050 004	MS2N04-C	1	–	82.2	88	55.5	44.0	73	177	M8	46.5	–	16.0
063 007	MS2N05-D	1	3.0	117.2	116	77.0	56.0	95	245	M8	56.5	–	16.0
080 012	MS2N06-D	2	2.5	117.2	160	102.0	77.0	–	324	M10	72.0	–	16.0
	MS2N06-E	1	–	–	–	–	–	100	–	–	–	–	–
100 019	MS2N06-E	2	2.5	151.4	160	102.0	77.0	–	324	M10	89.0	–	16.0
	MS2N07-D	1	–	–	–	–	–	119	–	–	–	–	–
100XC 030	MS2N07-E	1.5	3.0	175.6	197	113.5	89.0	–	375	M12/M16	89.0/140.0	–	24.0
	MS2N10-D	1	–	–	–	–	–	145	–	–	–	–	–
130-HP 045	MS2N07-D	1.5	–	211.0	200	91.0	100.0	–	458	M10 (10x)	–	178	25.0
		1	–	–	–	–	–	154	–	–	–	–	–
160-HP 070	MS2N10-D	1.5	10.0	248.0	255	96.0	127.5	–	504	M12 (10x)	–	228	26.0
		1	–	–	–	–	–	188	–	–	–	–	–

¹⁾ Do not exceed max. permissible screw-in depth for "M" threads

Further information about motors ➡ Chapter "IndraDyn S - MS2N servo motors"

IndraDyn S - MS2N servo motors

Smart Function Kit size	002	004	007	012	019	030	
Axial motor attachment	MS2N04-B0BTN	MS2N04-C0BTN	MS2N05-D0BRN	MS2N06-E0BRN	MS2N07-D0BRN	MS2N10-D0BHA	
Parallel motor attachment	MS2N04-B0BTN	MS2N04-C0BTN	MS2N05-D0BRN	MS2N06-D0BRN	MS2N06-E0BRN	MS2N07-E1BNN	
Encoder type	Absolute value encoder						
Brake	With holding brake						

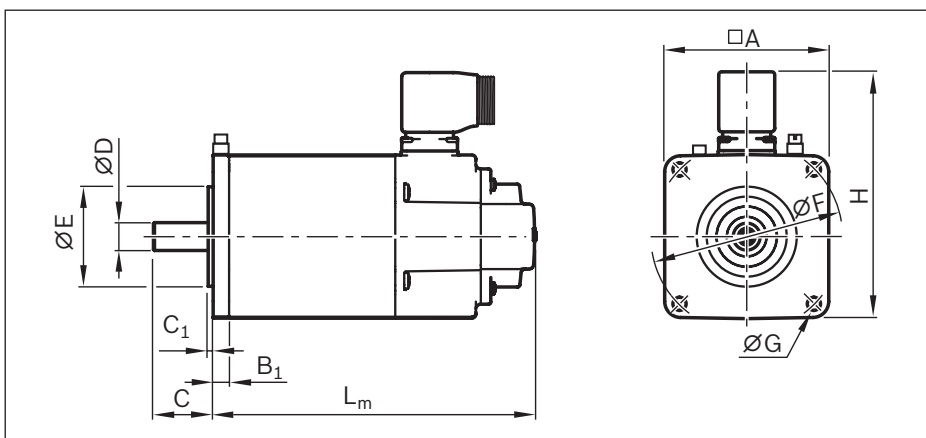

Motor representation, schematic

Motor code	Dimensions (mm)										
	$\square A$	B_1	C	C_1	$\varnothing D_{k6}$	$\varnothing E_{j6}$	$\varnothing F$	$\varnothing G$	H	L_m	
MS2N04-B0BTN	82	8	30	2.5	14	50	95	6.6	108	194.5	
MS2N04-C0BTN	82	8	30	2.5	14	50	95	6.6	108	226.5	
MS2N05-D0BRN	98	9	40	3.0	19	95	115	9.0	124	290.0	
MS2N06-D0BRN	116	14	50	3.0	24	95	130	9.0	156	261.0	
MS2N06-E0BRN	116	14	50	3.0	24	95	130	9.0	156	301.0	
MS2N07-D0BHA	140	18	58	4.0	32	130	165	11.0	203	438.0	
MS2N07-D0BRN	140	18	58	4.0	32	130	165	11.0	180	317.0	
MS2N07-E1BNN	140	18	58	4.0	32	130	165	11.0	180	375.0	
MS2N10-D0BHA	196	20	80	4.0	38	180	215	14.0	274	454.0	

	045	070
	MS2N07-D0BHA	MS2N10-D0BHA
	MS2N07-D0BHA	MS2N10-D0BHA

Version

- ▶ With holding brake
- ▶ Plain shaft without shaft seal ring
- ▶ Advanced multiturn encoder (CM) with AcuroLink interface
- ▶ IP64 enclosure protection class
- ▶ Special ground connection terminal near motor flange (used as needed)

	Motor data								Motor connection (cable)	Type code
	n_{max} (rpm)	M_0 (Nm)	M_{max} (Nm)	M_{br} (Nm)	J_m (kgm ²)	J_{br} (kgm ²)	m_m (kg)	m_{br} (kg)		
	6,000	1.75	5.9	5.0	0.00007	0.000040	2.7	0.7	1	MS2N04-B0BTN-CMSH1-NNNNE-NN
	6,000	2.80	12.0	5.0	0.00011	0.000050	3.7	0.7	1	MS2N04-C0BTN-CMSH1-NNNNE-NN
	6,000	7.90	31.3	10.0	0.00040	0.000110	7.3	1.1	1	MS2N05-D0BRN-CMSH1-NNNNE-NN
	6,000	9.70	32.0	15.0	0.00065	0.000140	9.0	1.5	1	MS2N06-D0BRN-CMSH2-NNNNE-NN
	6,000	13.0	49.0	15.0	0.00089	0.000140	11.5	1.5	1	MS2N06-E0BRN-CMSH2-NNNNE-NN
	4 000	35.5	73.2	36.0	0.00210	0.000410	20.0	2.5	2	MS2N07-D0BHA-CMVH2-NNNNE-NN
	6 000	22.0	73.2	36.0	0.00210	0.000410	17.5	2.5	1	MS2N07-D0BRN-CMVH2-NNNNE-NN
	6 000	25.8	128.5	36.0	0.00752	0.000410	23.0	3.0	1	MS2N07-E1BNN-CMVH2-NNNNE-NN
	4 000	82.4	142.0	53.0	0.00810	0.001470	35.0	5.0	2	MS2N10-D0BHA-CMVH2-NNNNE-NN

HCS01 drive controller (with integrated control system)

Smart Function Kit / size		002 / 004		007	012	019	030	045	070	
Size	Axial motor attachment	HCS01.1E-W0008	HCS01.1E-W0013	HCS01.1E-W0028		HCS01.1E-W0054				
	Parallel motor attachment			HCS01.1E-W0028		HCS01.1E-W0054				
Mains connection voltage	1 x AC	–	110 ... 230 V	–						
	3 x AC	200 ... 500 V	110 ... 230 V	200 ... 500 V						
Maximum current (output-side)	Axial motor attachment	A	8	13	28		54			
	Parallel motor attachment	A			28		54			
Power inlet Continuous current I_{LN} at U_{LN_rated} and P_{DC_cont}	Single-phase, without mains choke		A	–	8.3 ¹⁾		–			
	Three-phase, without mains choke	Axial motor attachment	A	2.5 A ¹⁾	4.5 ¹⁾	8 ¹⁾		25 ¹⁾		
		Parallel motor attachment	A			8 ¹⁾		25 ¹⁾		
			A							
Field bus interface	Profinet, Ethernet/IP, EtherCAT, Sercos III									
Protection class	IP20									

¹⁾ The actual phase current on the supply side highly depends on the application (cycle, load case etc.) and must be calculated.

Safety functions

Safety option	Safety function acc. to EN 61800-5-2		Safety level ²⁾ up to
L3 - STO	Safe standstill	Safe torque off (STO)	Category 4, PL e, SIL 3
S4 - Safe Motion	Safe standstill	Safe torque off (STO)	
		Safe brake control (SBC)	
		Safe operation stop (SOS)	
		Safe stop 1 – time prioritization (SS1-t)	Category 4, PL e, SIL 3
	Safe shutdown	Safe stop 1 – standstill prioritization (SS1-r)	Category 3, PL d, SIL 2
		Safe stop 2 (SS2-r)	
		Safe monitored deceleration (SMD) ¹⁾	
		Safe motion	
Safe motion	Safely reduced speed (SLS)		
	Safe maximum speed (SMS) ¹⁾		

¹⁾ Not defined in EN 61800-5-2

²⁾ Acc. to EN 13849-1 and EN 62061

	HCS01.1E-W0008-A-03	HCS01.1E-W0013-A-02	HCS01.1E-W0028-A-03	HCS01.1E-W0054-A-03
Size	1	1	2	3
A mm	50	50	70	130
B ₁ mm	215	215	268	268
B ₂ mm	160	160	213	213
C ₁ mm	220	220	220	220
C ₂ mm	196	196	196	196
Mass kg	0.72	0.72	1.7	4.22

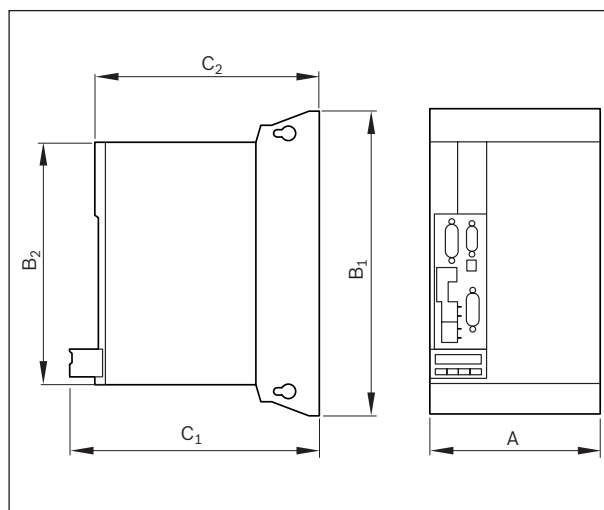

HSZ01 safety zone module

In the drive controller option S4, the safety zone module HSZ01.1 is used in addition
Also included in the scope of delivery: 2 x bus cable, 1 m length

Designation	HSZ01.1-D08-D04-NNNN		
Protection class	IP20		
Conductive contamination	Not permissible (They prevent conductive contamination, e.g. due to the installation of the devices in control cabinets of the protection class IP54 to IEC529.)		
Permissible installation position	Vertically in a control cabinet		
Weight	m	kg	0.65
Minimum distance from the top of the device	d_{top}	mm	40
Minimum distance from the bottom of the device	d_{bot}	mm	40
Minimum distance from the side of the device	d_{hor}	mm	-
Permissible ambient temperature range	T_{a,work}	°C	0 ... 55
Permissible relative humidity		%	5 ... 85
Cooling type	Natural convection		
Voltage supply			
Input, control voltage ¹⁾	U_{ext}	V	19.2 ... 30
Own consumption	P_{ext}	W	0.5
Output current ²⁾	I_{max}	A	3.4

¹⁾ When selecting the control voltage, observe the requirements of the door lock

²⁾ Total of all output currents at the outputs (excluding SDL_Ch2)

Note: The Smart Function Kit is suitable for use of the S4 safety technology in connection with the HSZ01 safety zone module. Integration into a global safety system, e.g. using PROFIsafe, is possible on request.

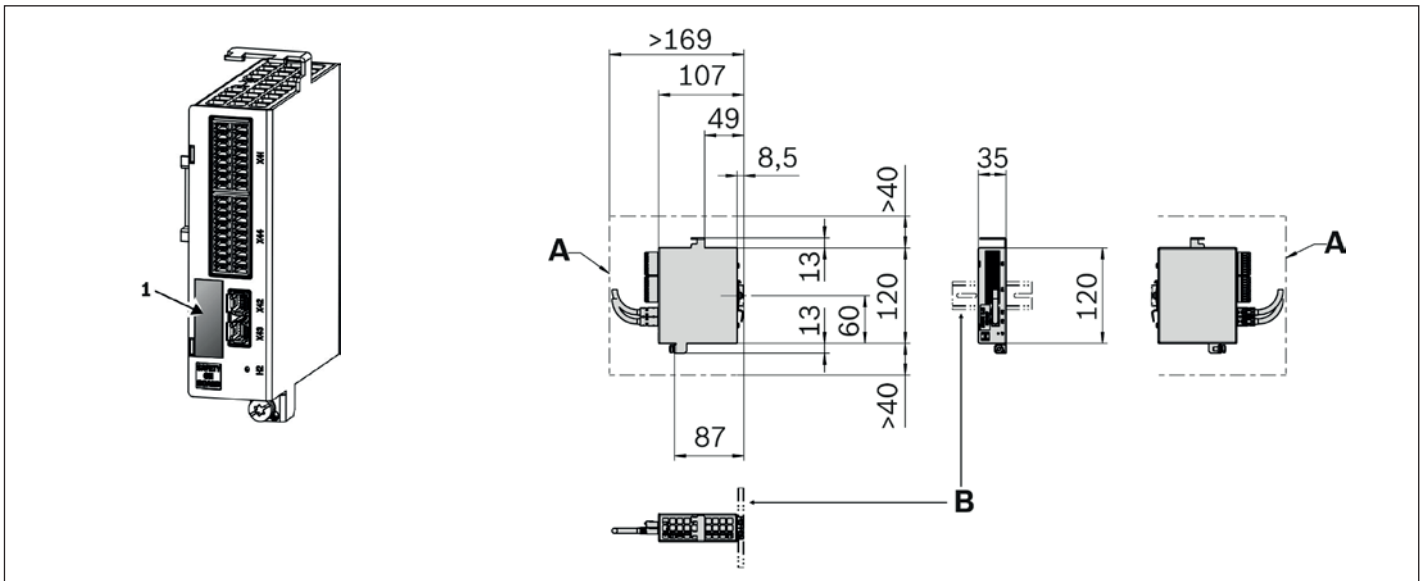

PR21 industrial PC

Operating system	Linux Ubuntu Core
CPU	Intel Atom E3815; 1.46 GHz
Storage	4G DDR3L, 1066 MHz RAM
Mass storage	32 GB eMMC onboard
Interfaces	1 × USB 3.0 2 × Realtek RTL8111E GbE Ethernet 1 × HDMI video port
RTC battery	RTC battery button cell BR2032
Assembly	DIN rail mounting
Input voltage range	DC 24 V + 25%, -20%
Power consumption	Maximum 20 W
Protection class	IP20

A₁	mm	30
B	mm	100
C₁	mm	70
C₂	mm	6.5
Mass	kg	0.4

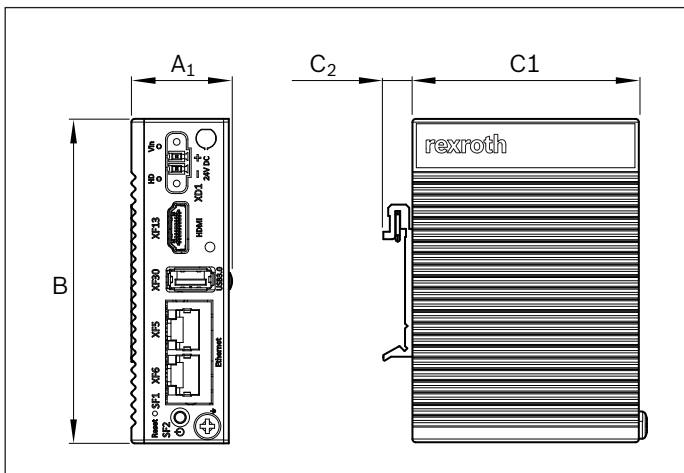

Force sensor

Features

- ▶ Corrosion-resistant stainless steel version
- ▶ High reproducibility
- ▶ Easy mounting directly at the EMC piston rod

Note

- ▶ If the process requires joining to a specified force value, a force sensor is required as otherwise, no stable process result can be achieved.
- ▶ Calibration certificate included in delivery.

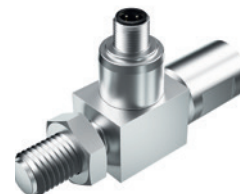

Metrological specifications

Smart Function Kit / size	002	004	007	012	019	030	045	070	
Measurement technology	Strain gauge (DMS)								
Compressive force measuring range ¹⁾	kN	3	6	10	15	20	40	55	75
Traction force measuring range	kN	0.3	0.6	1					
Protection type	IP67								
Operating load (of the measuring range)	%	150							
Breaking load (of the measuring range)	%	300							
Non-linearity (of the measuring range)	%	± 0.3							
Relative creeping (of the measuring range)	%	0.1							
Hysteresis (of the measuring range)	%	0.1							
Temperature drift at zero point (of the measuring range per Kelvin)	%	0.02							
Temperature drift above measuring range (of the measuring range per Kelvin)	%	0.02							
Compensated temperature (min ... max)	-20 °C ... +80 °C								
Working temperature (min ... max)	-30 °C ... +80 °C								
Resolution	12 Bit								

¹⁾ Smaller measuring ranges on request

Electrical specifications

Smart Function Kit / size	002	004	007	012	019	030	045	070	
Output signal (0kN)	0.909 V ± 0.01			0.625 V ± 0.01	0.476 V ± 0.01	0.244 V ± 0.01	0.179 V ± 0.01	0.132 V ± 0.01	
Output signal (measuring range)	0 ... +10 V								
Nominal rating	N/V	330	660	1100	1600	2100	4100	5600	7600
Power supply voltage	14 ... 30 V								
Current consumption	8 mA (24V)								
Bandwidth	1 kHz ± 0.2								
Connector	Plug M12 x 1 4-pin								

Electrical connection

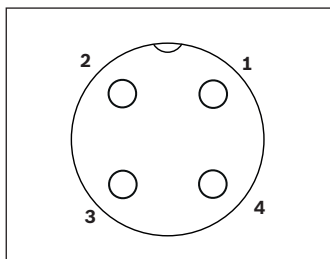

Force sensor

- 1 Supply (+)
- 2 -
- 3 GND
- 4 Output

Connection cable

- 1 brn
- 2 -
- 3 blu
- 4 blk

Connection cable length 15 m;
with M12 connector with free cable ends

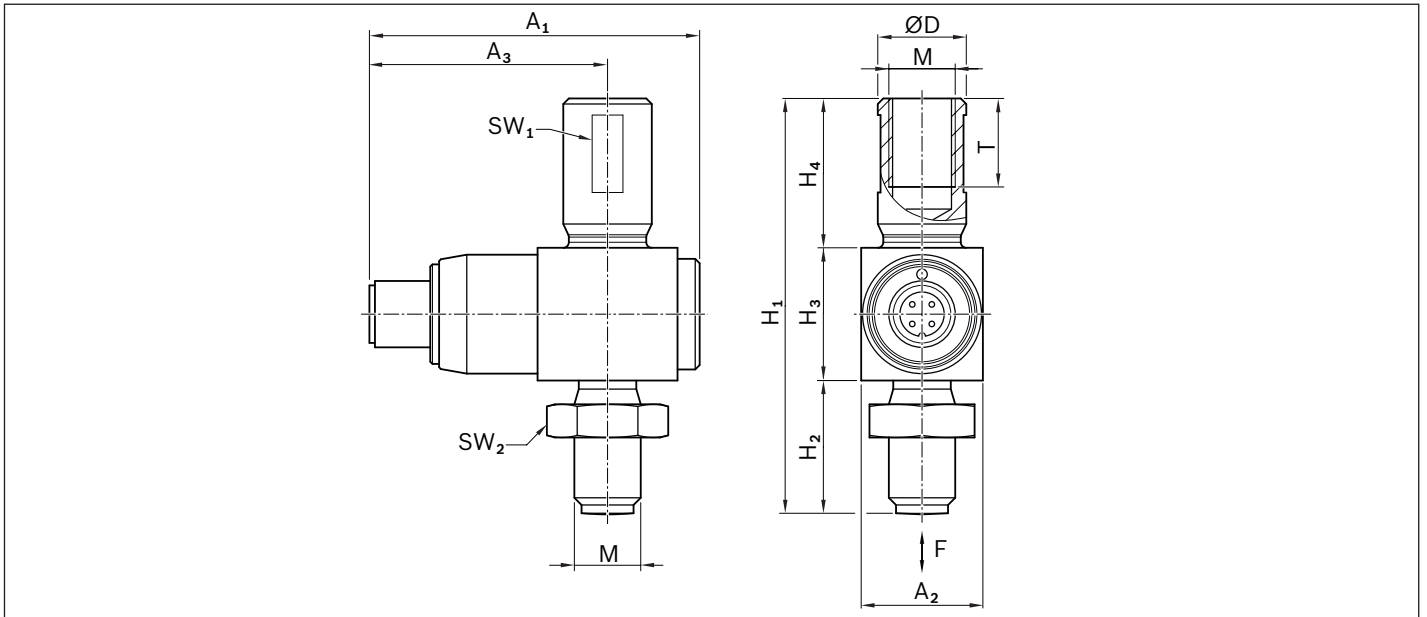

Smart Function Kit / size		002	004	007	012	019	030	045	070
A ₁	mm	69			71	74	82	83	98.5
A ₂	mm	25.3			35		37.5	50	
A ₃	mm	56			57		58	66	
ØD	mm	18	24.5		30		50	50	65
H ₁	mm	75	100		134		185	185	195
H ₂	mm	24	32		40		57	57	70
H ₃	mm	24	33		50			50	40
H ₄	mm	27	35		44		78	78	85
M		M12 x 1.25	M16 x 1.5		M20 x 1.5		M36 x 2	M33 x 2	M42 x 2
T	mm	16	23		29		49	49	59
SW ₁	mm	16	22		26		46	46	55
SW ₂	mm	19	24		30		55	50	65

Ordering data

Smart Function Kit / size	Material number Force sensor
002	R156623001
004	R156633001
007	R156643001
012	R156653001
019	R156663001
030	R156673001
045	R156683001
070	R156693001



Data connection cable

Model	M12, 4-pin, A-coded
Connection 1st side	Straight female connector
Connection 2nd side	Open cable ends
Cable length	15 m
Number of wires/wire cross-section	4 × 0.34 mm ²
Shielding	With shielding
Operating voltage	30 V
Operating current per wire	4 A
External Ø	Less than 4.7 mm ± 5%
Drag chain values	10 million
Bending radius (moved)	10 × external Ø
Temperature range (stationary)	-40...+80 °C
Temperature range (moved)	-25...+80 °C
Protection class	IP67 in screwed condition
Cable color	Black
Approvals	UL, CSA, CE, UKCA





Connecting cable material number: **R901533653**

Accessories

Fastening elements

Flange fastening	Foot mounting
	

Electrical accessories

Uninterruptible power supply VAU	Mains filter NFE/NFD	Power supply unit VAP01	Panel PC WR21	Ethernet cable 5 m RKB
				

For accessories data and further accessories, please see: www.boschrexroth.de/smart-function-kit

Software

General information

Access to front end via	Web browsers, such as Firefox, Chrome
HMI device display formats	>10 inch, software adapts automatically
Languages in HMI	German, English
Number of user levels	Two: user, admin
"User" permissions	Select program, start program, view log file, change language
"Admin" permissions	Just as "User" and in addition machining programs, configuring evaluation elements, performing start-up, launching a reference run, accessing configuration parameters
Availability of software updates	Available for download on website
Software license	No additional license required for SFK software
Front end hosting	Hosting by PR21 industrial PC
Connection between PR21 and HMI device	Connection via network cable or wi-fi (no wi-fi router included)

Dashboard

Dashboard data	Production statistics, evaluation of last produced parts, live sequence, live process data
Production statistics data	Number of OK parts, number of NOK parts and efficiency
Time horizon production statistics	Unlimited (as long as memory is available), statistical reset possible
Live sequence display	Program steps of the selected program with currently executed step or live curve.
Data in live curve	X-axis: Path or time Y-axis: Force
Configurability of the live curve	Display in force/path diagram or force-time diagram possible
Process live data	Position, force, speed
Additional cycle data	Max. position, max. force, cycle time

Sequence creation

Programming scheme	Programming via graphical blocks which are bayed one after the other. A block corresponds to a sequence step which is filled with parameters.
Available sequence blocks	Start position, position, join on force (with position monitoring), Join on position (with force monitoring), drive to signal, pause, wait for signal, set output, tare, set variable, check target window force/path.
Data recording	Sequence section in which data is recorded can be defined using the Start data recording and End data recording blocks
Adjustable parameters	Depending on the sequence step, e.g. speed, acceleration, target position, target force, maximum force, maximum position, ...
Definition of parameter values	In the front end or transfer from higher-level PLC using variables (max. 100 variables usable)
Configurable termination criteria	Exceeding maximum force or maximum position
Handling of false entries	Parameters are subject to a logic check that prevents serious incorrect inputs.
Max. number of programs	99
Max. number of steps per sequence	500
Behavior between sequence steps	Slurring of movement, no braking between steps (Exception: start position).
Relevance of sequence steps for evaluation	Selectable during program creation whether program step for evaluation is taken into account or not.
External interaction during program execution	Interaction via digital (via HCS01) or virtual (via field bus) inputs and outputs.
Number of digital inputs and outputs	7 inputs (1 of which is pre-assigned for E-Stop), 1 output
Number of virtual inputs and outputs	16 inputs, 16 outputs
Format of program export/import	Export to / import from JSON file

Process and data

Monitoring options	Force monitoring, position monitoring
Control behavior	Position control
Manual operations (jog mode)	Continuous, absolute and relative process with individually adjustable speed
Stop command options	About HMI, digital I/Os, field bus
Error response	Abort program, display of error message, if necessary prompt for error acknowledgment
Program abort response time	2 ms + braking time
Live data evaluation	Program abort when abort criteria are exceeded, or when the window defined in the "Check force/path" target window is violated, no evaluation of trends etc.
Max. data recording frequency	500 Hz (one data point every 2 ms)
Max. number of measuring points	Total duration press cycle / 2 ms
Process data archiving	Storage of each press cycle in the internal database
Archived and exportable data	Time stamp, evaluation (OK or NOK), max. position, max. force, cycle time, Serial number, program name, force/path curve with evaluation elements
Filter function in press history	Can be filtered by date, program name and rating
Max. number of archived press cycles/curves	Approx. 1 million (free space ~25 GB)
Format of curve export	JSON
Memory usage	approx. 12.6 kb per second data recording for an average reference process

Reference curves and curve evaluation

Basis of evaluation	Evaluation elements in conjunction with reference curve
Available evaluation elements	Limits, windows, envelope curves (points can be defined flexibly)
Type of reference curve	Force/path diagram
Recommended maximum number of reference curves per program	30
Measurements	Force, position (only actual values, no lead)
Max. number of points in envelope curve	100
Max. number of evaluation elements per program	50
Addition of evaluation element by	Graphical drawing in web HMI
Editability of an evaluation element after creation	Graphically displaceable or by adjusting the x/y coordinates of the points
Display evaluation result	OK/NOK
Display crosses with evaluation elements	Visual representation in force/path curve, output in export file (JSON)
Fault diagnostics for NOK result	Output NOK, visual representation in force/path curve
Response behavior in case of NOK result	Output of the NOK result in the dashboard ➔ Evaluation elements are not a termination criterion during the cycle
Evaluation/response to trends	Trends cannot be evaluated within the SFK software
Evaluation of individual evaluation elements	Holistic evaluation of the force/path curve, no separate evaluation of individual evaluation elements
Field bus evaluation results	OK/NOK readable as status bit
Evaluation elements via fieldbus	Limits of the evaluation element window can be read out via variables
Process data via fieldbus	Maximum force in the window and position at maximum force can be read out via variables

Interfaces

Available interfaces:	Field bus, REST API, WebSocket API, OPC/UA, digital I/Os
Supported field bus protocols	SERCOS III, PROFINET, EtherCAT, EtherNet/IP
Fieldbus commands	Start program, set program active, position absolute, position relative, delete error, stop motion, reboot drive, tare force sensor, start reference run, set system variable, lock participant, set reference, read system variable (e.g. max. position, max. force and time of last cycle)
Real-time data via field bus	Active program number, live position, live speed, live force
Field bus (0 or 1) status information	Program active, last pressing OK, last pressing NOK, sensor tared, press ready, error, warning, request possible, response available, notification available
Trigger possibilities	7 digital inputs (1 of which is pre-assigned for E-Stop), 1 digital output on the HCS01 drive controller; 16 bits each, which can be used as virtual input or output (via field bus)
Traceability possibility	Optional allocation of a serial number (max. 28 characters) at program start via field bus
HMI	SFK front end in visual representation only accessible via web browser; all HMI functionalities are also available via REST API; to a limited extent also via OPC/UA
Remote maintenance capability	Access via remote maintenance software (e.g. TeamViewer, VNC Viewer, ...)
Readable variables via OPC/UA	Active program ID, current error, current position, current program step, current force, current speed, system database online (0 or 1), system available (0 or 1), free space, program running (0 or 1)
Methods via OPC/UA	Abort command, delete error, display Y-parameter, position, reboot entire system, read command history, read I/Os, read S or P parameters, read out command with call context, read out SMC variable, read out Y parameters, switch between parameter and operating mode, set program active, set reference, start the program, start the reference run, tare the force sensor, write S or P parameters, write SMC variables, write Y parameters
Retrievable data via REST API	Account data, authentication data, configuration, curves, programs, users, evaluation elements, activity, start-up
Fieldbus function blocks available for	Siemens TIA Portal, Rexroth Indra Works and Allen Bradley Studio 5000 Logix Designer

Configuration and CAD data

The definition of the SFK with its nominal forces was based on an internal defined reference cycle. We recommend that you calculate every application in our selection and design tool LinSelect in order to determine the solution that is right for the application.



On the basis of this selection, CAD files can then be generated and downloaded in the online configurator.

Configurators and tools



<https://www.boschrexroth.com/en/xc/products/product-support/econfigurators-and-tools/index>















Ordering code

Example			004	200	- Axial -	Safe Torque Off	With force sensor	- 5
Size dependent on nominal force	=	2 kN: 002 4 kN: 004 7 kN: 007 12 kN: 012 19 kN: 019 30 kN: 030 45 kN: 045 70 kN: 070						
Travel range dependent on size		002 35 - 400 mm 004 40 - 400 mm 007 65 - 400 mm 012 80 - 400 mm 019 70 - 400 mm 030 90 - 400 mm 045 110 - 400 mm 070 130 - 400 mm						
Motor attachment	=	Axial						
								
		Parallel						
								
Safety function Drive controller	=	Safe Torque Off / Safe Motion						
Force sensor ¹⁾	=	Without force sensor With force sensor						
Cable length	=	5 m 10 m						

¹⁾ Observe the notes in the chapter "Force sensor"

Additional documentation

Required and supplementary documentation

	Title	Document number	Document type
	Electromechanical cylinders EMC	R999000473	Catalog
	Electromechanical cylinders EMC-HP	R999002086	Catalog
	Instructions for electromechanical cylinders EMC	R320103102	Instructions
	Instructions for electromechanical cylinders EMC HP	R320103219	Instructions
	IndraDrive Cs drive assemblies with HCS01	R911322209	Description of the project planning
	MS2N synchronous servo motors	R911347582	Description of the project planning
	IndraControl PR21	R911389663	Instructions
	SMC	R911343864	Manual
	Smart Function Kit	R320103194	Instructions
	Smart Function Kit software	R320103208	Instructions
	Smart Function Kit - Field bus	R320103209	Instructions
	Smart Function Kit - OPC-UA + REST-API	R320103210	Instructions
	IndraDrive integrated safety technology "Safe Torque Off" (from MPx-16)	R911332633	Application description
	Integrated safety technology "Safe Motion" (from MPx-18)	R911338919	Application description
	Add-on components and accessories	R911306139	Description of the project planning

The Rexroth documentation is available for download at www.boschrexroth.com/mediadirectory.

Ambient conditions

Smart Function Kit / size	002	004	007	012	019	030	045	070
Operation ambient temperature	0 °C ... 40 °C, above 40 °C loss of performance							
IP protection class	Mechanics: Standard IP54 (up to IP65 possible) Control cabinet hardware: IP20							
Duty cycle	%	100						

Bosch Rexroth AG

Ernst-Sachs-Straße 100
97424 Schweinfurt, Germany
Phone +49 9721 937-0
www.boschrexroth.com

Find your local contact person here:

www.boschrexroth.com/contact

