

# Integrated measuring system IMS

for ball and roller rail systems

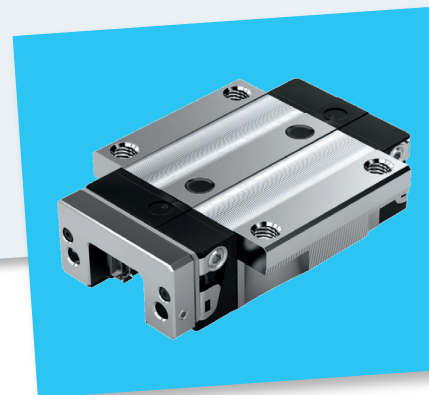

[www.boschrexroth.com](http://www.boschrexroth.com)

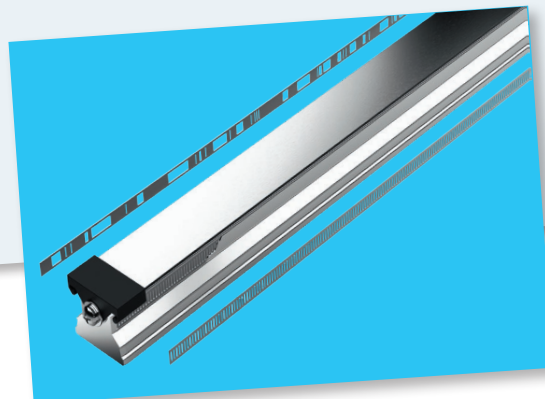
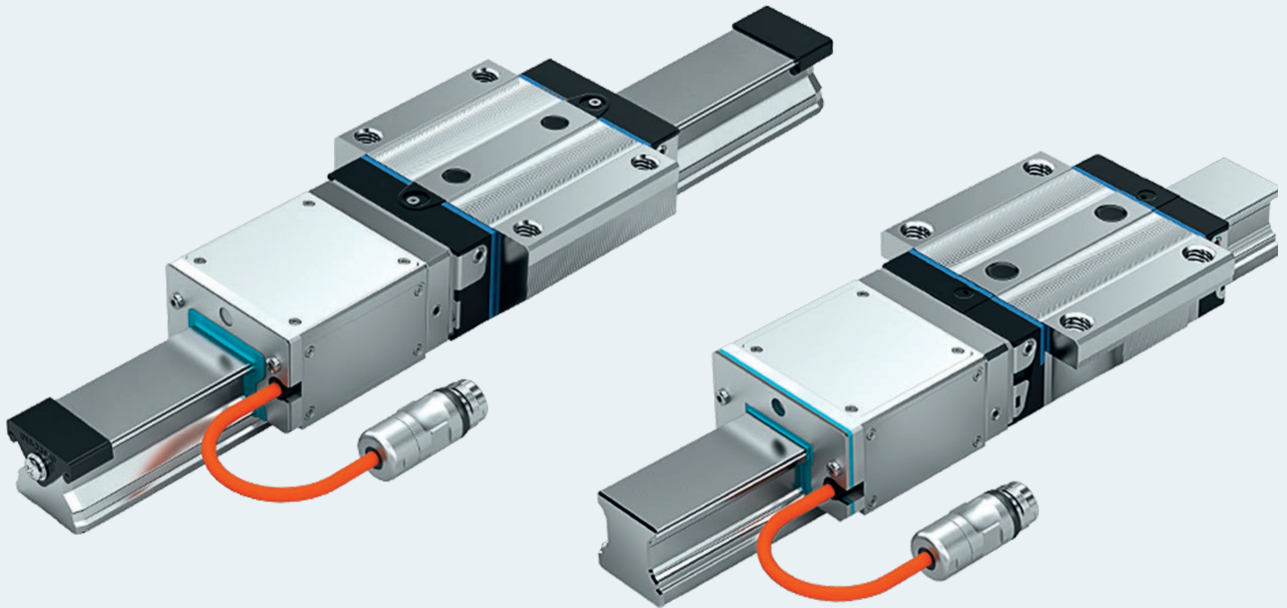

# Contents

New features at a glance		4
Product overview	Product description	5
	Structural design	8
Technical data	General technical data and calculations of runner blocks	9
	Description and technical data of scanner (IMS-I / IMS-A)	10
	Description and technical data of scanner (IMS-I)	12
	Description and technical data of scanner (IMS-A)	14
	Description and technical data of connectors and cable	16
	Description and technical data of guide rail	18
	Description and technical data of overall system	20
	Ball runner blocks - technical data and drawings	Product overview and type designation, ball runner blocks
Ball runner blocks FNS		26
Ball runner blocks FLS		28
Ball runner blocks SNS		30
Ball runner blocks SLS		32
Ball runner blocks SNH		34
Ball runner blocks SLH		36
Ball guide rails - technical data and drawings		Product overview and type designation, ball guide rails
	Ball guide rails SNS with cover strips and protective caps	40
	Ball guide rails SNS with plastic mounting hole plugs	41
Roller runner blocks - technical data and drawings	Product overview and type key roller runner blocks	42
	Roller runner blocks FNS	44
	Roller runner blocks FLS	46
	Roller runner blocks SNS	48
	Roller runner blocks SLS	50
	Roller runner blocks SNH	52
	Roller runner blocks SLH	54
	Roller guide rails - technical data and drawings	Product overview and type designation, roller guide rails
Roller guide rails SNS with cover strip and protective end caps		58
Roller guide rail SNS with plastic or steel mounting hole plugs		59
Accessories	Cable	60
Further information	Safety instructions	62
	Ordering example for ball rail system IMS-I	64
	Ordering example for roller rail system IMS-A	65
	Mounting instructions / maintenance instructions	66
	Inquiry / order form	67

**IMS – Integrated measuring system: absolute/incremental – inductive – accurate - integrated**

<b>Feature</b>	<b>Properties</b>	<b>Advantages</b>	<b>Customer benefits</b>
<b>Absolute</b>	<ul style="list-style-type: none"> <li>▶ Absolute measuring system with absolute and incremental coded scales</li> </ul>	<ul style="list-style-type: none"> <li>▶ Absolute position information immediately after switching on the system</li> <li>▶ Absolute position information is stored directly in the rail</li> </ul>	<ul style="list-style-type: none"> <li>▶ Space-saving and cost advantage, since no additional components are required (e.g., battery)</li> <li>▶ Savings in time: Switch on without reference run minimizes ramp-up time of the machine</li> <li>▶ Quality improvement: Avoiding damage to the tool and workpiece e.g. at power failure</li> </ul>
<b>Incremental</b>	<ul style="list-style-type: none"> <li>▶ Incremental measuring system with incrementally coded scale and integrated reference marks</li> </ul>	<ul style="list-style-type: none"> <li>▶ Incremental position information immediately after switching on the system</li> <li>▶ Absolute position information is generated via the reference marks</li> </ul>	<ul style="list-style-type: none"> <li>▶ Space-saving and cost advantage, since no additional components are required</li> </ul>
<b>Inductive</b>	<ul style="list-style-type: none"> <li>▶ All components made of steel</li> <li>▶ The inductive measuring principle allows for non-contact measurement</li> </ul>	<ul style="list-style-type: none"> <li>▶ Scale and sensors are not corrupted by external magnetic fields</li> <li>▶ Wear and maintenance free</li> <li>▶ Resistant to contamination and vibration</li> <li>▶ Not susceptible to EMV interference</li> </ul>	<ul style="list-style-type: none"> <li>▶ Wear and maintenance-free therefore reduced downtime and no maintenance costs</li> <li>▶ Universal application: <ul style="list-style-type: none"> <li>– For all applications with linear guide and external measurement system</li> <li>– In special applications e.g. induction hardening machines, welding equipment</li> <li>– For applications with shock or vibrations (e.g. presses, linear motors)</li> </ul> </li> </ul>
<b>Precise</b>	<ul style="list-style-type: none"> <li>▶ Repeatability: <math>\pm 0.25 \mu\text{m}</math></li> <li>▶ Position resolution: <math>0.025 \mu\text{m}</math></li> <li>▶ System accuracy: <math>\pm 4 \mu\text{m/m}</math></li> <li>▶ Coefficient of linear expansion like steel: <math>11 \times 10^{-6} \text{K}^{-1}</math></li> </ul>	<ul style="list-style-type: none"> <li>▶ Exact positioning even under dynamic load changes</li> <li>▶ Outstanding circuit dynamics due to high position resolution</li> <li>▶ Small rail deviation even with multi-axis interpolation</li> <li>▶ No thermal compensation necessary when processing steel</li> </ul>	<ul style="list-style-type: none"> <li>▶ Improvement of quality through excellent workpiece quality</li> <li>▶ Increase productivity by increase in machinery dynamics</li> <li>▶ Cost optimization through elimination of thermal compensation</li> </ul>
<b>Integrated</b>	<ul style="list-style-type: none"> <li>▶ Full integration of the measurement function in the linear guide</li> <li>▶ Interchangeability also in measurement systems</li> </ul>	<ul style="list-style-type: none"> <li>▶ Simple machine design due to the full integration</li> <li>▶ No sealing air necessary due to protection class IP67</li> <li>▶ Minimum mounting time: the guide assembly is mounted at the same time as the measuring system</li> <li>▶ No adjustment of the measuring system necessary</li> <li>▶ Very good protection of the measuring system components against damage</li> <li>▶ Optimization of service by Rexroth interchangeability even for measuring system components</li> </ul>	<p>Cost benefits through:</p> <ul style="list-style-type: none"> <li>▶ Time savings during design, installation and start-up</li> <li>▶ Elimination of components, stop and mounting surfaces when compared to external measurement systems</li> <li>▶ Elimination of all components for sealing air</li> <li>▶ Order of only the relevant components in the event of servicing</li> </ul>

## Product description

The integrated measuring system from Rexroth consists of:

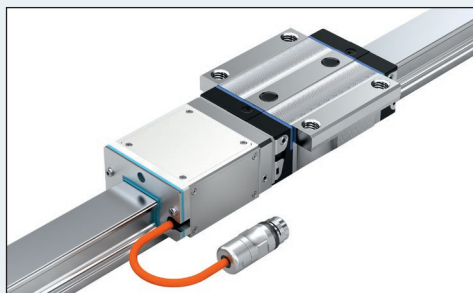
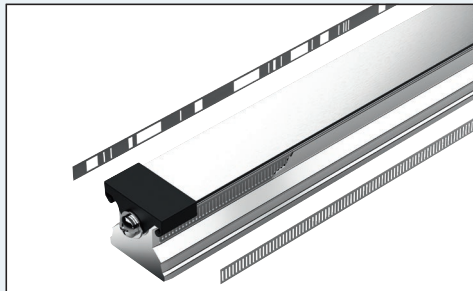

### Rexroth ball or roller runner block

- ▶ with mounted adapter plate

available in:

- ▶ different sizes
- ▶ various accuracy classes
- ▶ various preload classes

### Rexroth scanner

- ▶ including sensors, electronics, connecting cable and connector
- ▶ already mounted on the ball or roller runner block

### Rexroth guide rail

- ▶ with integrated scale
- ▶ with integrated reference marks (IMS-I)
- ▶ with integrated absolute code band (IMS-A)
- ▶ optional with cover strip or mounting hole plugs (plastic or steel)

IMS by Rexroth:

**I**ntegrated **M**easuring **S**ystem

IMS-**I** (Incremental)

IMS-**A** (**A**bsolute)

Integrating the measuring technology into the linear guide results in a mechatronic system which combines the ability to guide mechanical loads and to measure length into one product.

No external measuring systems are needed.

## Product description

### Runner blocks

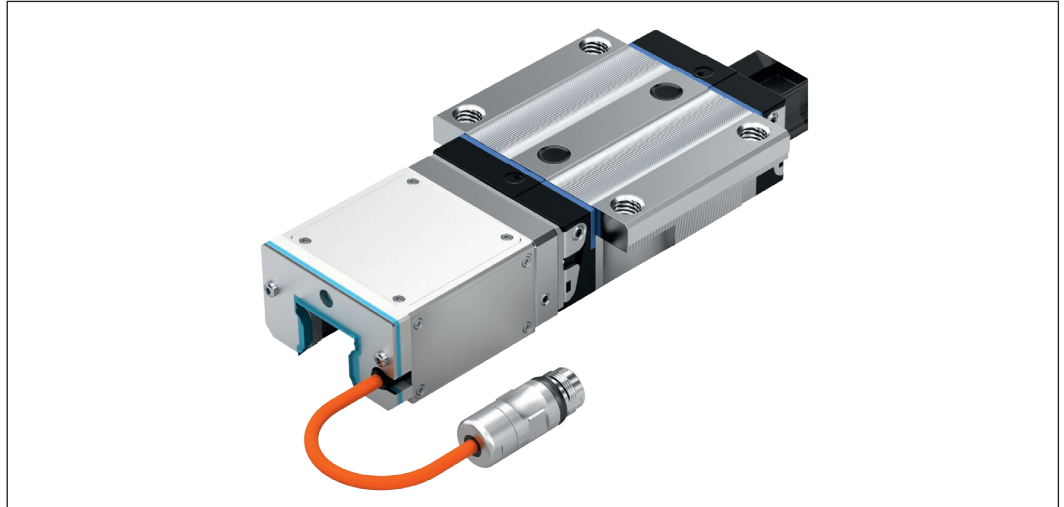

#### Runner block with mounted adapter plate and mounted scanner

- ▶ Same mounting hole pattern and mounting dimensions as standard runner block
- ▶ Adapter plate allows scanner<sup>1)</sup> to be replaced during servicing without removing the runner block.

<sup>1)</sup>For further information, see the following chapter.

Scanner fastening screws must be accessible. There must sufficient clearance at the end of the rail for pulling the scanner off.

### Guide rail

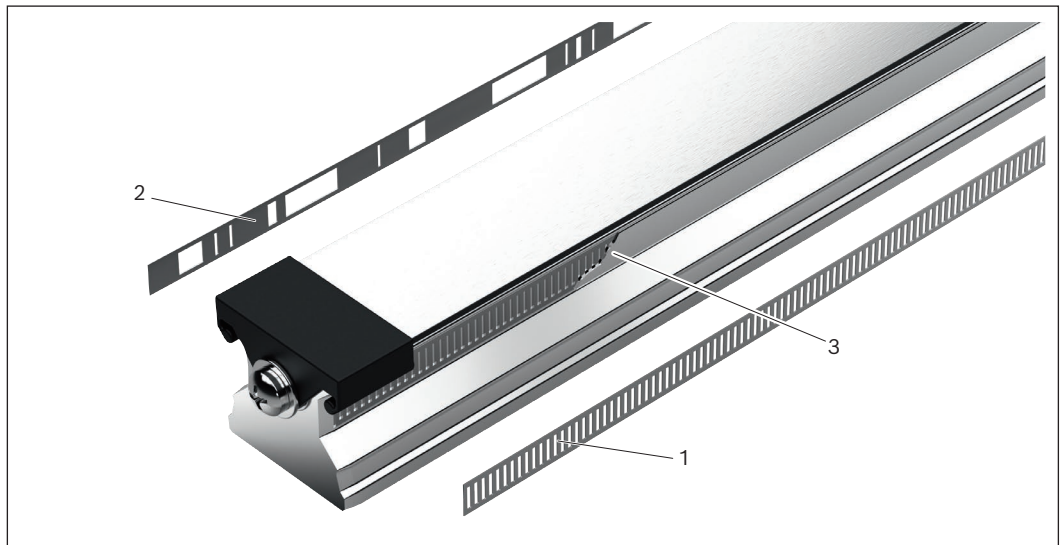

#### Guide rail with integrated steel scales

- ▶ Same mounting hole pattern and mounting dimensions as standard guide rails.
- ▶ Incremental scale (1), and optional absolute code band (2) (IMS-A), or reference marks (IMS-I).
- ▶ Scales (1) / (2) protected by a hermetically sealed welded stainless steel band (3).
- ▶ For further information, see the following chapter.

## Integrated measuring system IMS for ball and roller rail systems

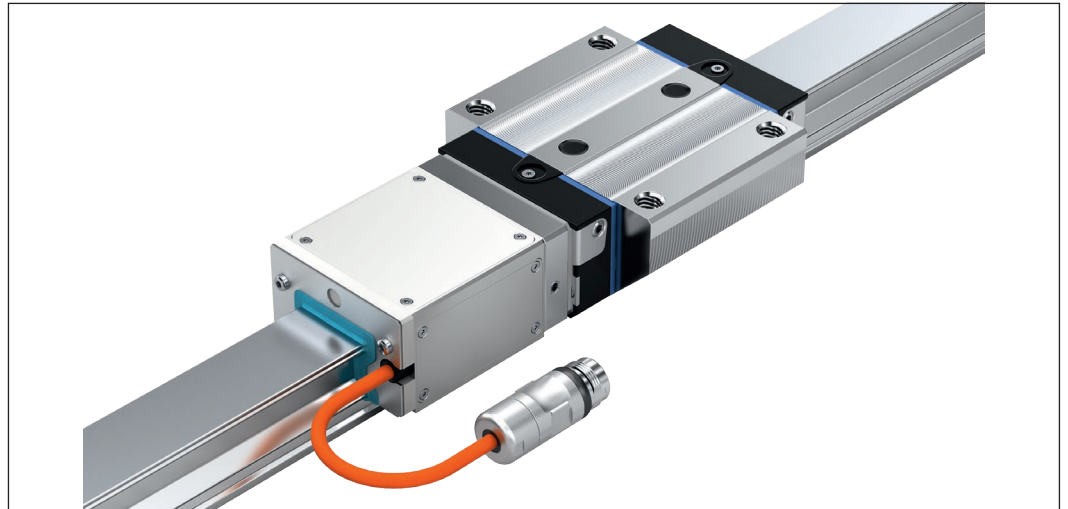

Rexroth ball rail and roller rail systems can be supplied with a completely integrated, inductive linear measuring system. The length measuring system consists of a scanner, a scale, reference marks, and the absolute code band. The Scanner with sensors is mounted on the runner block. As it travels over them, it evaluates the scale, the reference marks or the absolute code band integrated in the rail. This mechatronic system combines the functions of guidance and measurement into one unit and opens up new, ideal opportunities in machine design.

### Highlights: Integrated measuring system

- ▶ The guide system and the measuring system form one unit, building on standard guide elements (use of standard runner block on IMS guide rail is possible)
- ▶ No additional space required
- ▶ No external mounting surfaces required for measuring systems
- ▶ No measuring inaccuracies due to deviations in parallelism between the measuring system and the guideway
- ▶ Retrofit and replacement is simple through the proven Rexroth interchangeability
- ▶ Position measurement directly at the workpiece/tool
- ▶ Protection class IP67 with no additional measures required
- ▶ Full integration of the measuring system components into the guide means no complex installation or tuning work is needed
- ▶ The runner block, scanner and guide rail can be replaced individually if required

### Inductive measuring principle

- ▶ Contact-free scanning ensures zero maintenance
- ▶ Resistant to water, oil, dust, shavings, etc.
- ▶ Insusceptible to magnetic fields
- ▶ One-piece guide rails: Standard length up to 4500 mm
- ▶ Several scanners can be mounted on one rail

### Incremental measuring principle

- ▶ Precise position detection through a high-precision, incremental scale paired with single reference marks
- ▶ High resolution thanks to 40 µm signal period

### Absolute measuring principle

- ▶ Precise, absolute positioning by an additional absolute code band
- ▶ No battery necessary for buffering the absolute information

## Structural design

- 1** Guide rail with scale, reference marks or absolute code band
- 2** Front seal
- 3** Support plate
- 4** Scanner
- 5** Adapter plate (fixed to the runner block)
- 6** Runner blocks
- 7** Cable and connector

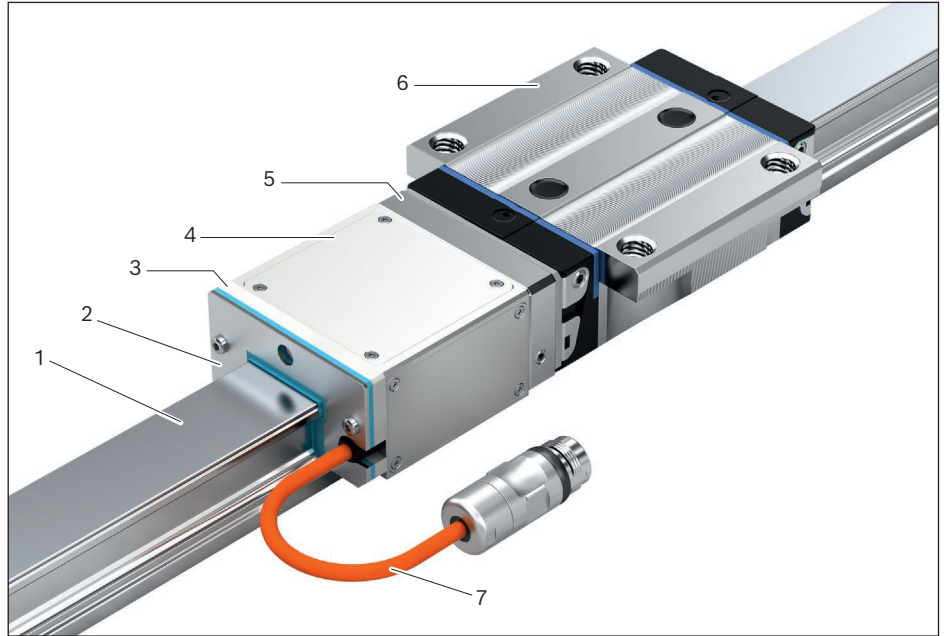

- 8** Reference marks or absolute code band
- 9** Incremental scale
- 10** Cover provided by welded stainless-steel band (depending on the version, both sides)
- 11** Sensor for reference marks or absolute code band
- 12** Measuring sensor
- 13** Evaluation electronics

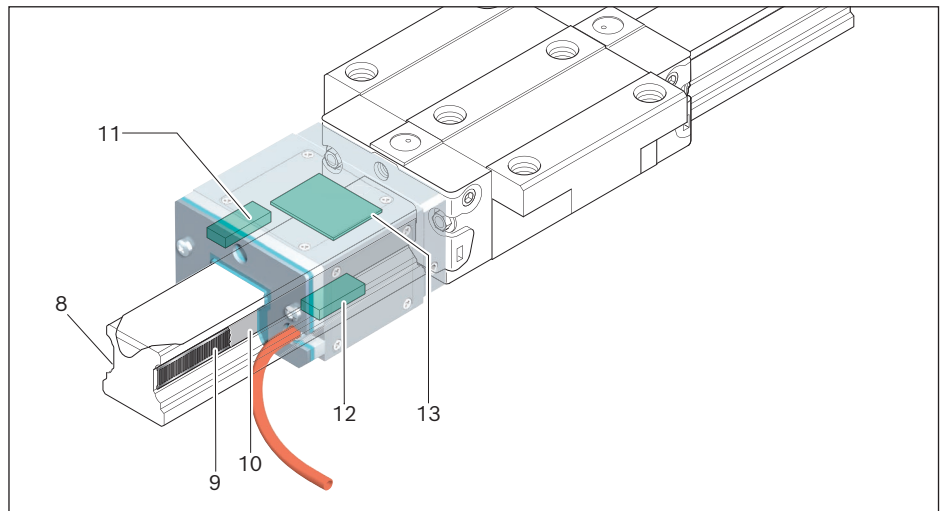



# General technical data and calculations of runner blocks

## Loads due to forces and moments on the runner block

The forces acting on the system are distributed among the guiding wagons depending on the runner block. The loads due to forces and torques resulting from the effective forces need to be calculated for each runner block when performing the life expectancy calculation.

All load calculations require an infinitely rigid mounting base and an infinitely rigid structure.

The service life calculation for the IMS is performed in a similar way to the service life calculation for profiled rail systems without a measuring system. Please refer to the appropriate catalog for ball/roller rail systems.

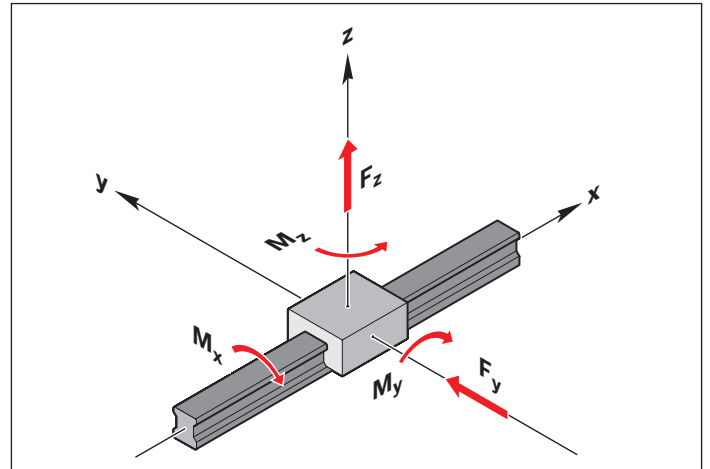

▲ Load on a single runner block due to forces and torques.

The following table shows the arrangements that are most commonly found in practice. For the IMS runner block, whichever scenario is selected, the relevant values for  $F_{y \max}$  and  $M_{z \max}$  must be complied with in the application. The respective values are given in the chapters on ball / roller runner blocks.

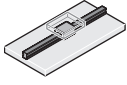
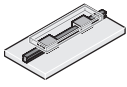
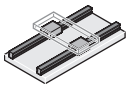
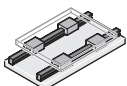
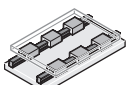
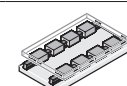
Version	Arrangement	Forces		Moments		
		in z-direction Lift-off/down force	in y-direction Side load	about the X-axis Torsional moment	about the Y-axis Longitudinal moment	about the Z-axis Longitudinal moment
1	1 rail 1 runner block 	$F_z$	$F_y$	$M_x$	$M_y$	$M_z$
2	1 rail 2 runner blocks 	$F_z$	$F_y$	$M_x$	-	-
3	2 rails 2 runner blocks 	$F_z$	$F_y$	-	$M_y$	$M_z$
4	2 rails 4 runner blocks 	$F_z$	$F_y$	-	-	-
5	2 rails 6 runner blocks 	$F_z$	$F_y$	-	-	-
6	2 rails 8 runner blocks 	$F_z$	$F_y$	-	-	-

## Description and technical data of scanner (IMS-I / IMS-A)

### Scanner on the runner block

The basic design of the scanner is explained here, using a ball runner block as an example. The scanner for roller runner blocks differs only in minor details.

The scanner is mounted on the runner block via the adapter plate. It is no wider and no higher than the runner block. The mounting hole pattern of the runner block remains unchanged. Advantage: The mounting of the runner block on the adjoining structure remains the same even with a measuring system.

The scanner contains the non-contacting, inductive sensor system for the incremental or absolute measuring function. It also contains the required electronics.

### Scanner

The aluminum scanner housing accommodates all of the other scanner components. It is fastened via an adapter plate pre-mounted to the runner block, and thus forms one unit with it. The adapter plate allows the scanner to be replaced without having to remove the runner block itself from the rail. The housing protects the electronic components from dirt and impacts.

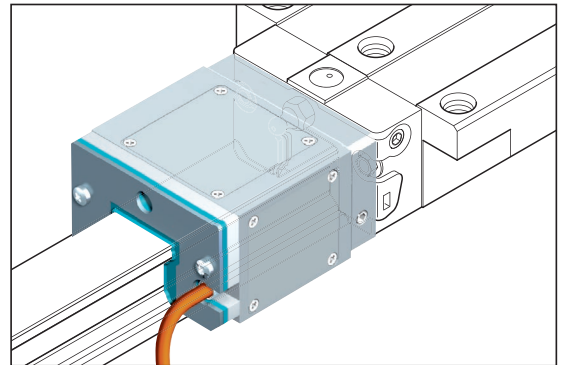

### Measuring sensor

The non-contacting measuring sensor, which scans the incremental scale in the guide rail, is located on one side of the scanner. It consists of a multitude of transmitter and receiver coils. The measuring sensor is always located on the same side as the cable.

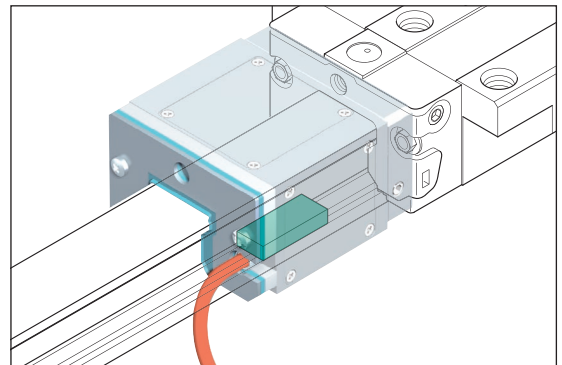

### Reference sensor/ absolute sensor

The reference sensor or absolute sensor is located on the opposite side of the measuring sensor. This reference sensor scans the reference marks, the absolute sensor, the absolute code band in the guide rail, thus allowing the absolute position of the runner block on the guide rail to be determined.

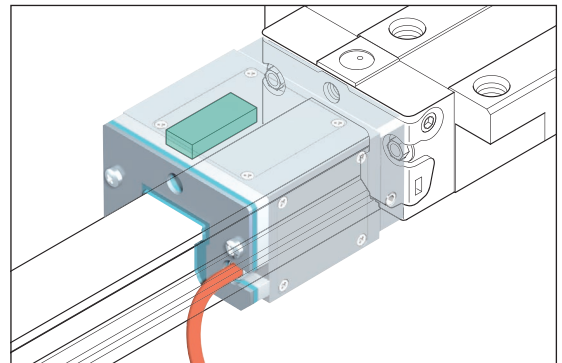

**Evaluation electronics** The evaluation electronics contains all components for generating, processing, calibrating and transmitting signals. These signals are evaluated by external electronics (e.g. IndraDrive servo controller from Rexroth).

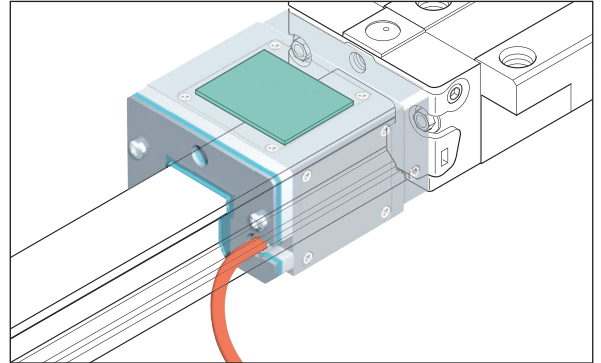

**Seal** To provide added protection, a front seal (1) is screwed onto the scanner. This prevents water, oil, cooling lubricant, shavings and dust from working their way into the scanner from the end face. The bottom side of the scanner is protected by longitudinal seals (3).

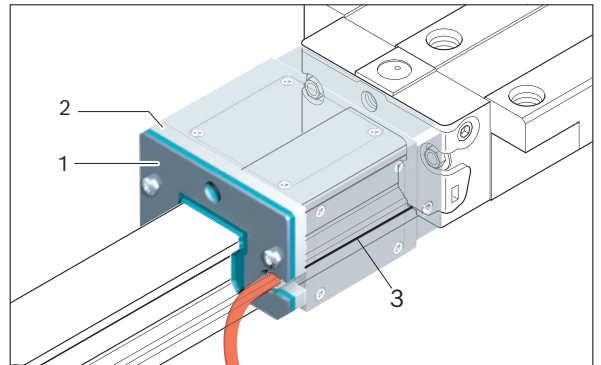

**Support plate** The support plate (2) is mounted between the front seal and the scanner. It has a little clearance to the guide rail and limited oscillations of the scanner for applications with strong vibrations and shocks.

**Connector/Cable** The connector and cable connect the scanner to external electronics.

**Technical data**

<b>Operating temperature</b>	0 ... 50 °C
<b>Storage/transport temperature</b>	-10 ... 70 °C
<b>Relative air humidity during storage</b>	max. 95%
<b>Relative air humidity in operation</b>	max. 80% at 20 °C
<b>MTTF</b>	100 years

## Description and technical data of scanner (IMS-I / IMS-A)

### Safe-Motion

None of the output signals may be used for drive-integrated safety functions for the controller. Exceptions: Safety functions which do not rely on the encoder signals.

### Scanner mounting side

The scanner mounting side defines the side upon which the reference edge (2,  $\Delta$ ) of the runner block is located in relation to the incremental scale (1) and the spacing  $T_1$  (3) of the guide rail when the scanner is mounted.

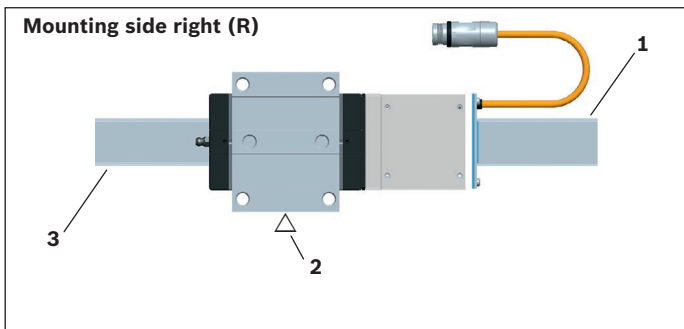
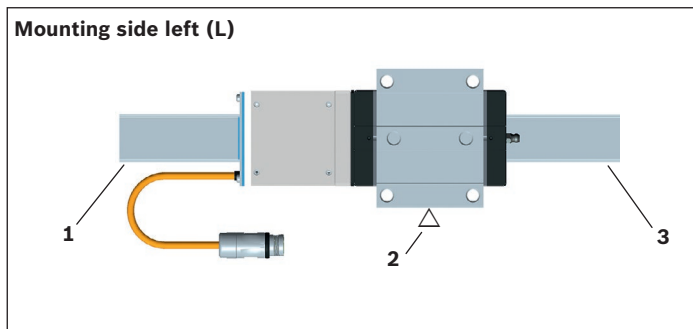

### Design notes:

The direction for sliding on the IMS Runner Block must be defined during the construction.

IMS Runner Block must be slid on in such a way that the cable outlet is always located on the side of the incremental scale of the IMS Guide Rail.

### Motion direction

Motion direction for positive counting direction of sensor signals (for analog and digital output signals)

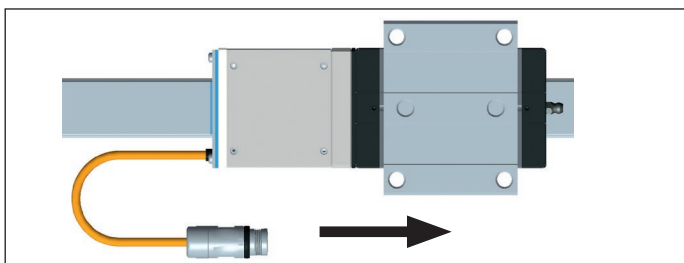

## Description and technical data of scanner (IMS-I)

### Interfaces

#### Analog output signals, sinusoidal signals 1 V<sub>SS</sub> (Option I1)

#### Incremental signals

The sinusoidal incremental signals A and B are phase-shifted 90° relative to each other and have a typical signal amplitude of 1 V<sub>SS</sub>.

Signal amplitude: A, B = 1 V<sub>SS</sub> (±0.1 V)

The illustrated output signal sequence (B phase-lagged to A) relates to motion of the scanner in the positive counting direction (see graph).

#### Reference mark signal

The differential reference mark signal RI has an amplitude of approx. -0.7 V when inactive (low).

In the active state (high), the amplitude is +0.7 V.

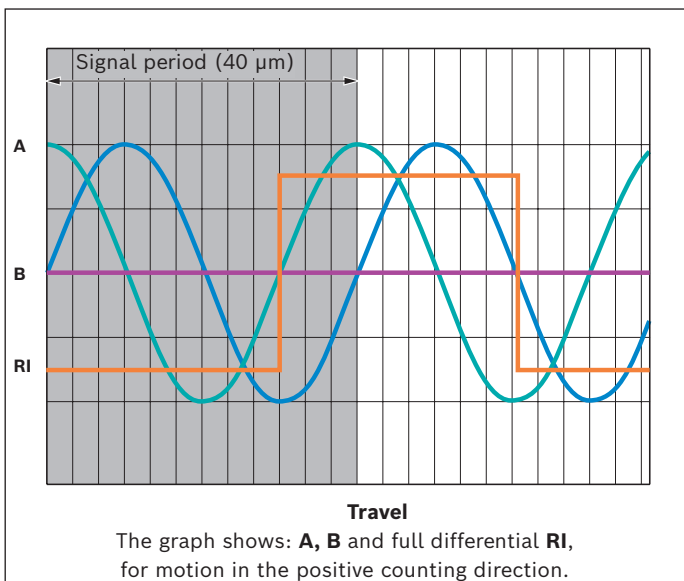

# Description and technical data of scanner (IMS-I / IMS-A), continuation

## Interface circuitry for analog output signals

The stated amplitudes apply for operation with a terminating resistor  $Z_0 = 120 \Omega$ .

$$\begin{aligned} R_A &= 27.40 \Omega \\ R_{RI} &= 0 \Omega \\ Z_0 &= 120.00 \Omega \\ U_{comp} &= 1.65 \text{ V} \end{aligned}$$

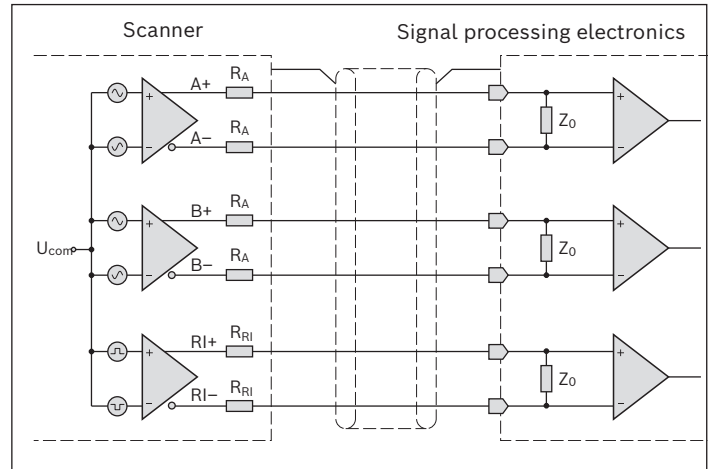

## Digital output signals

### Square-wave TTL output signals through an integrated interpolation unit (Option I2, I3, I4)

#### Incremental signals

The digital incremental signals A and B comply with the EIA/TIA-422-A standard. They are 90° phase shifted and have the following signal levels:

$$U_{high} > 2 \text{ V}$$

$$U_{low} < -2 \text{ V}$$

The switching response times are  $\leq 100 \text{ ns}$  at a capacitive load of  $\leq 1000 \text{ pF}$ .

#### Reference mark signal

The differential reference mark signal RI has the same electrical characteristics as the incremental signals.

The stated amplitudes apply for operation with a terminating resistor  $Z_0 = 120 \Omega$ .

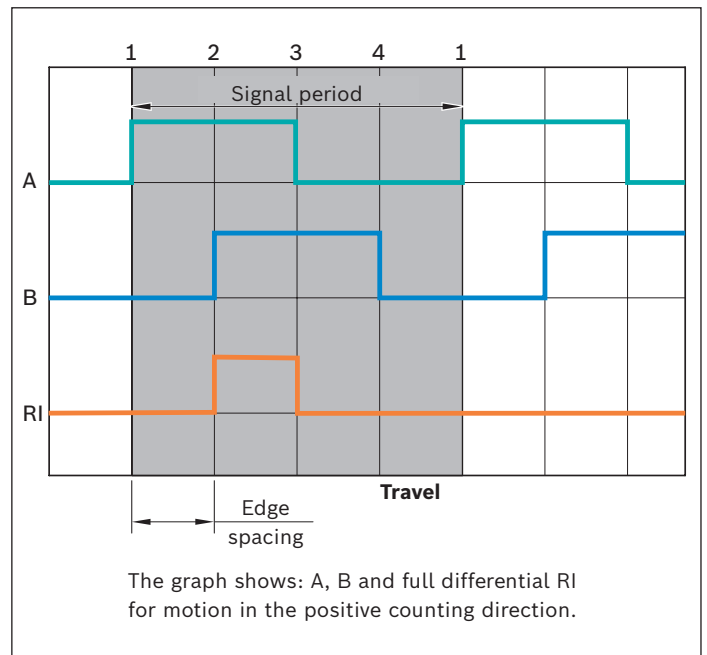

## Resolution

Measuring systems with digital output signals are available with resolution rates of 1  $\mu\text{m}$ , 5  $\mu\text{m}$ , 10  $\mu\text{m}$ .

Option	Resolution (edge spacing)	Signal period	Max. scanner speed
	( $\mu\text{m}$ )	( $\mu\text{m}$ )	(m/s)
I2	1	4	2.0
I3	5	20	5.0
I4	10	40	5.0

## Technical data for IMS-I

<b>Power supply</b>	4.75 V ... 12.6 V (at connector) Overvoltage protection: max. 18 V DC
<b>Current consumption</b>	1V <sub>SS</sub> /5 V: 300 mA; 1V <sub>SS</sub> /12 V: 170 mA; TTL/5 V: 350 mA; TTL/12 V: 190 mA

# Description and technical data of scanner (IMS-A)

## Interfaces

### HIPERFACE® (optional: HF)

HIPERFACE® is a registered trademark of SICK STEGMANN GmbH.

HIPERFACE® stands for high performance interface and is a hybrid interface. It is composed of the analog process data channel on which the sinusoidal and cosine signals (analog option I1) are transferred differentially and almost instantly, as well as the bidirectional parameter channel for transmitting the absolute position and other different parameters. Furthermore, an electronic nameplate for identification and for storing drive-relevant information in the motor feedback is available. IMS-A with HIPERFACE® interface is the optimum solution for REXROTH drive systems.

#### Technical data

<b>Power supply</b>	7 V ... 28 V (at connector)
<b>Current consumption</b>	250 mA at 7 V
<b>Maximum measuring speed</b>	5 m/s
<b>Resolution of the digital interface (µm)</b>	1.25 µm

### SSI – Synchronous Serial Interface (options: S1, S2, S3, S4)

With the synchronous serial interface (SSI), the absolute position information is transferred to higher-level evaluation electronics via serial data transmission. Parallel to the serial data transmission, the incremental sinusoidal and cosine signals (analog option I1) are also available for enhancing the control performance.

For the different requirements of the evaluation electronics in terms of the position resolution, the following SSI configurations can be chosen:

#### Technical data

Option	S1	S2	S3	S4
<b>Coding</b>	Binary	Binary	Binary	Gray
<b>Number of bits (position)</b>	22	25	27	28
<b>Parity</b>	straight	straight	–	–
<b>Error bit</b>	yes	yes	yes	no
<b>Warning bit</b>	yes	yes	no	no
<b>Resolution of the digital interface / µm</b>	10	1	0.25	0.125
<b>Max. clock frequency / MHz</b>	2			

<b>Power supply</b>	4.75 V ... 28 V (at connector)
<b>Current consumption</b>	5 V, 300 mA
<b>Maximum measuring speed</b>	5 m/s

### DRIVE-CLiQ (Option: DQ)

DRIVE-CLiQ is a protected trademark of Siemens.

This system interface is used for connecting measuring systems to the drive components from Siemens. IMS-A with DRIVE-CLiQ interface enables easier start-up, as the interface has an electronic nameplate. This contains IMS-A-specific data, which enables error-free configuration of the drive system during start-up.

#### Technical data

<b>Power supply</b>	13.2 V ... 30.8 V (at connector)
<b>Current consumption</b>	110 mA maximum
<b>Maximum measuring speed</b>	5 m/s
<b>Resolution</b>	0.025 µm

### FANUC (Option: FN) (in preparation)

IMS-A with serial FANUC interface ai offers robust, reliable, and purely serial communication for high-performance tooling machines with FANUC control units.

#### Technical data

<b>Power supply</b>	4.6 V ... 12.6 V (at connector)
<b>Current consumption</b>	350 mA maximum
<b>Maximum measuring speed</b>	5 m/s
<b>Resolution</b>	0.025 µm

### Cable Structural design

- ▶ Sheath: polyurethane (PUR)
- ▶ Color: RAL 2003 orange
- ▶ Exterior diameter 5.0<sup>±0,30</sup> mm
- ▶ Oil resistant
- ▶ RoHS compliant
- ▶ UL-Type 20963

### Mechanical properties (standard cable)

Bending radius for one-time bending (stationary): 20 mm  
Alternating bends not allowed

### Cable length

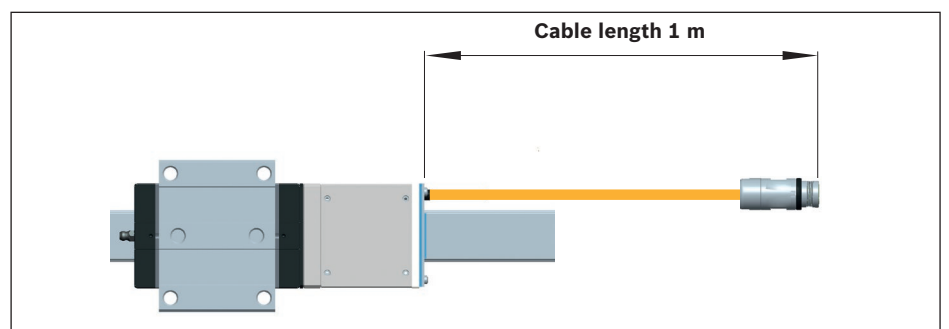

# Description and technical data of connectors and cable

## Connector type

Protection type: IP67 (when locked)

### ▼ Option A: RGS1722 (round connector)

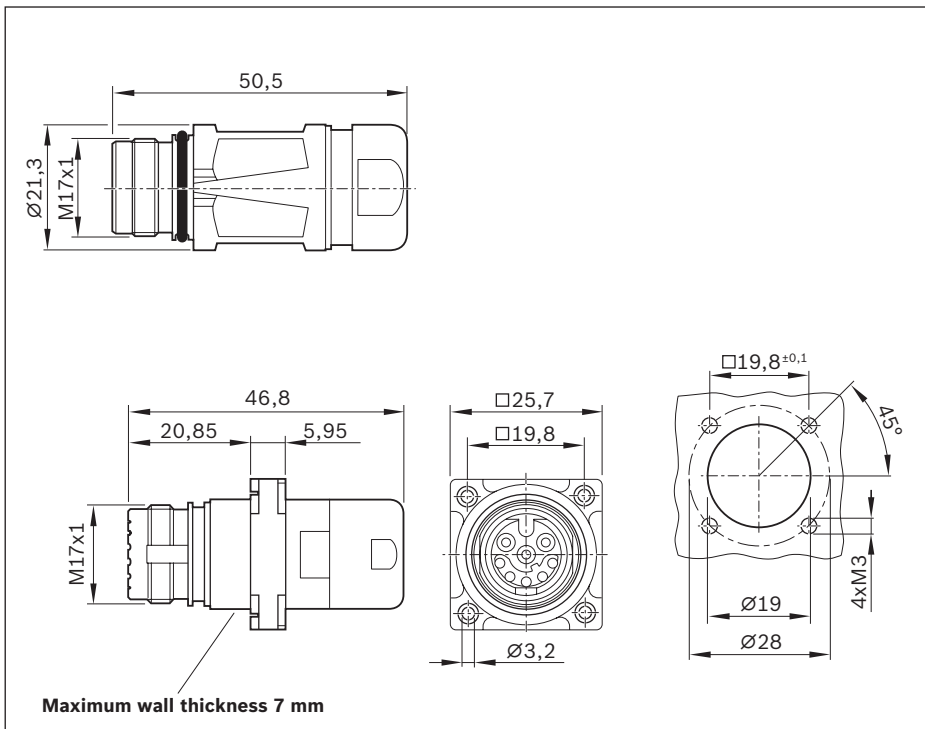

### ▼ Option B: RGS1714 (flange housing) for mounting in front or rear walls

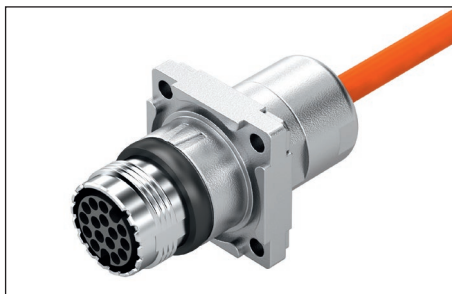

### ▼ View contact side for A and B

Design with male contacts

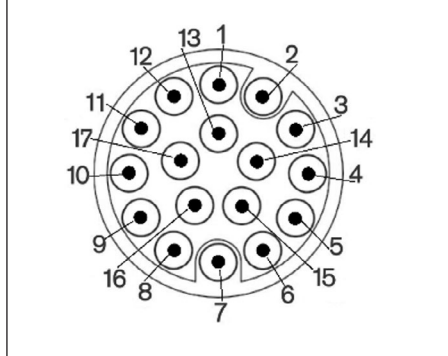

M17, 17 pol. Connei Pin no.	Signal assignment	Function
1	Inner shield	Inner cable shield
2	A +	Analog/digital path information
3	A -	
4	GND	Power supply GND
5	B +	Analog/digital path information
6	B -	
7	Data +	IMS-I: for services purposes only
8	Data -	IMS-A: HIPERFACE®/SSI data line
9	EncCLK+ / RI+	IMS-I: Reference mark signal
10	EncCLK- / RI-	IMS-A: SSI-CLOCK
11	VDD	Power supply VDD
12	n.c.	
13	n.c.	
14	n.c.	
15	0 V Sense	Sense line* GND
16	5 V Sense	Sense line* VDD
17	n.c.	
Housing	Outer shield	Outer shield contacted via connector housing

\* If there is no voltage adjustment via sense lines available, the sense lines can to be switched parallel to the power supply lines.

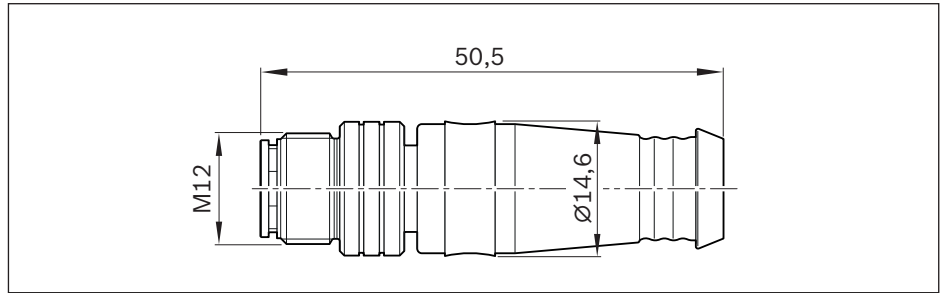

**▼ Option C: M12 / 8-pin for DRIVE-CLiQ**

Design with male contacts

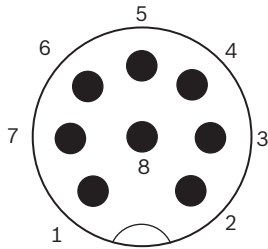

M12, 8 pin Pin no.	Signal assignment	Function
1	24 V	Power supply 24 V
2	Data +	For service purposes only
3	RXP	Received data positive
4	RXN	Received data negative
5	0V	Power supply 0 V
6	TXN	Sent data negative
7	TXP	Sent data positive
8	Data -	For service purposes only
Housing	Outer shield	Outer shield contacted via connector housing

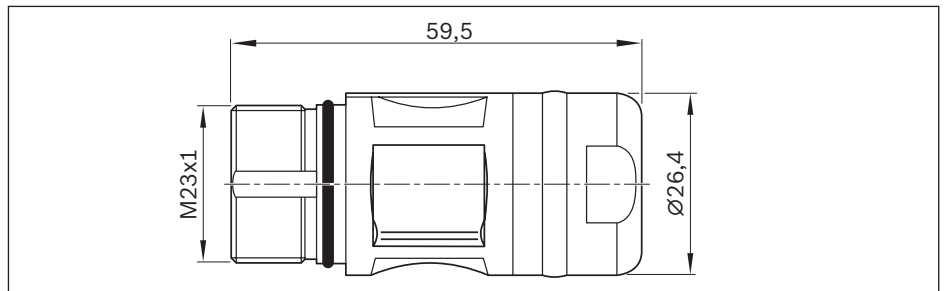
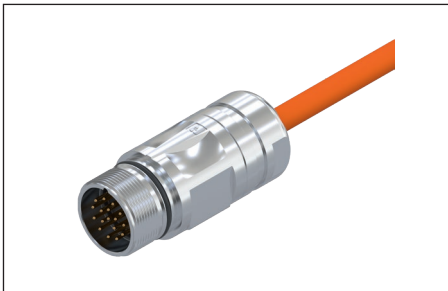
**▼ Option D: M23 / 17pin for FANUC**

Design with male contacts

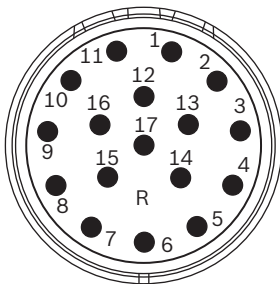

M23, 17 pin Pin no.	Signal assignment	Function
1	5 V	Power supply 5 V
7		
8	RD	ai positive data cable
9	*RD	ai negative data cable
10	GND	Power supply GND
14	Data+ / SD	For service purposes only
17	Data- / *SD	
Housing	Outer shield	Outer shield contacted via connector housing

## Description and technical data of guide rail

### Guide rail

The incremental scale and the reference marks and the absolute code band are integrated in the guide rail for the measuring system. All tuning work has therefore been completed at the plant prior to shipment. The user does not incur any extra installation costs for the measurement system. Moreover, the system does not take up any additional space. Usage together with clamping or braking elements is prohibited.

### Mounting the guide rail and covering the fastening screws

The guide rail is mounted from above. The mounting holes can be sealed by a cover strip (4) or with plugs (5).

### Scale

The scales as they are known (1/2) are integrated in the guide rail. These consist of a steel mesh band. With IMS-I an incremental scale is integrated into the guide rail as well as reference marks, with IMS-A these reference marks are replaced with an absolute code band.

#### ► Incremental scale (1):

When scanned, the scale itself delivers only ascending or descending numerical values (incremental signals). The precision of the scale is determined by the accuracy class.

#### ► Absolute code band (2):

The absolute code band provides absolute position information when the system is switched on.

#### ► Reference marks:

When scanned, the scale itself delivers only ascending or descending numerical values (incremental signals).

This incremental measuring principle does not allow the absolute position of the measuring system to be detected.

An additional reference is needed to determine the absolute position of the runner block on the guide rail.

This can be provided in different ways:

- Single reference mark
- External mechanical stop or switch

### Scale protection

The cover (3) (stainless-steel band) protects the scale (1/2) from contamination. The stainless-steel band is connected to the rail by laser welding. This ensures the protection class IP67.

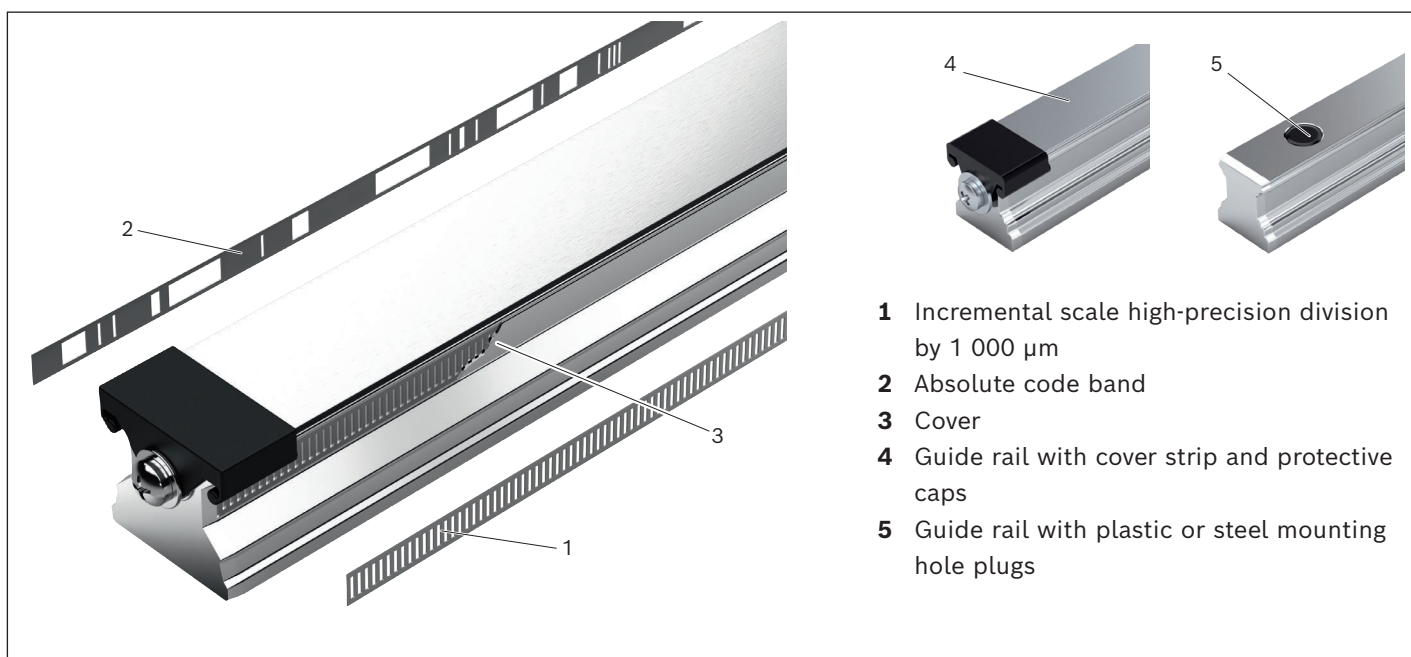

**Single, absolute reference mark**

A single, absolute reference mark is a bore that is machined into the guide rail on the side opposite the scale. It is closed with a brass pin to protect it from contamination and damage. This sensor must travel past this reference mark to detect the position.

Up to 5 single reference marks ( $R_1 \dots R_5$ ) can be machined into the guide rail (please state the required positions when ordering). The minimum distance between two reference marks is 10 mm. For the admissible positions of the reference marks, see the section on “ball guide rails”.

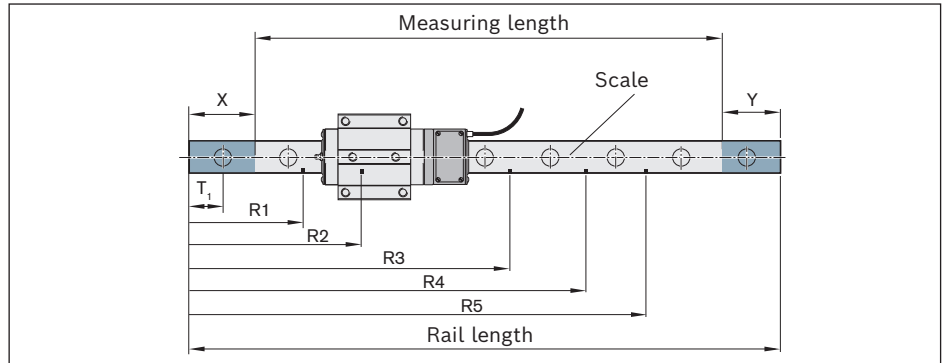

## Description and technical data of overall system

### The accuracy of length measurement

The accuracy of length measurement is determined primarily by:

- the division of the incremental scale
- the scan and signal processing in the scanner

Distinction is made between the position deviations over relatively long travel distances e.g. for the entire length of the rail and the position deviations within a period of division.

### Position deviations at the same position

The repeatability is the maximum deviation of the position that can occur when multiple driving on the same position from both directions. This is less in any measurement position than  $\pm 0.25 \mu\text{m}$ .

### Position deviations within a division period

The position deviations within one pitch period of the scale ( $1\,000 \mu\text{m}$ ) are determined by the signal period of the measuring device and by the quality of the division and its scan.

At any measuring point, they are less than  $\pm 0.75 \mu\text{m}$  ( $\approx 0.75\%$  of the division period). This is of vital importance to the accuracy of the positioning operation as well as for the speed control during the slow, uniform moves of an axis and thus for surface quality and processing quality.

#### ▼ Position deviation ( $\mu\text{m}$ ) within a pitch period

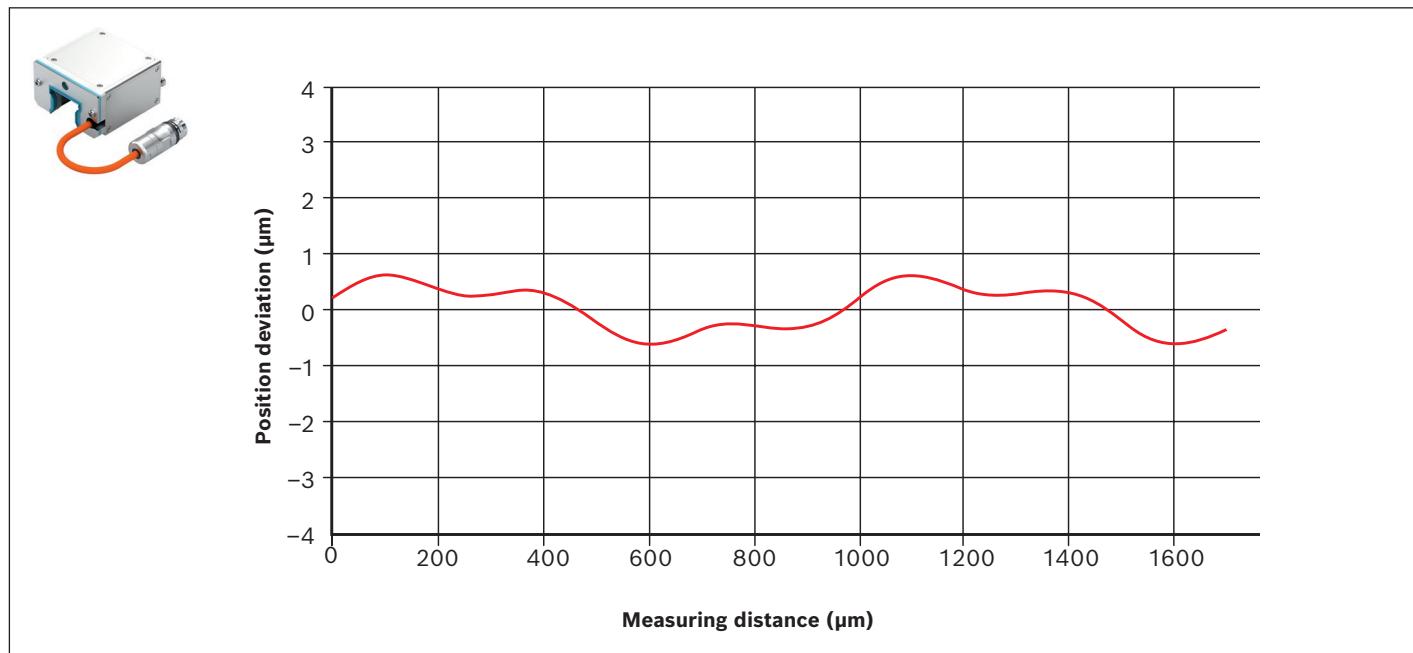

### Position accuracy over the measurement travel

The accuracy of the scale in the guide rail is specified in accuracy classes, which are defined as follows:

The extreme values  $\pm E$  of the measuring curves for any, max. 1 m length of measured travel are within the maximum deviation  $\pm A$  (at 20 °C). The deviation A is dependent on the length of the guide rail (see fig.)

The extreme values  $\pm E$  m is determined during the final test and specified in the measurement report.

The linear lead deviation is documented in the supplied measurement report of the guide rail.

The lead deviation can be compensated with the thermal linear expansion (see section “Thermal behavior”) in the drive control system.

#### ▼ Accuracy class of the scale

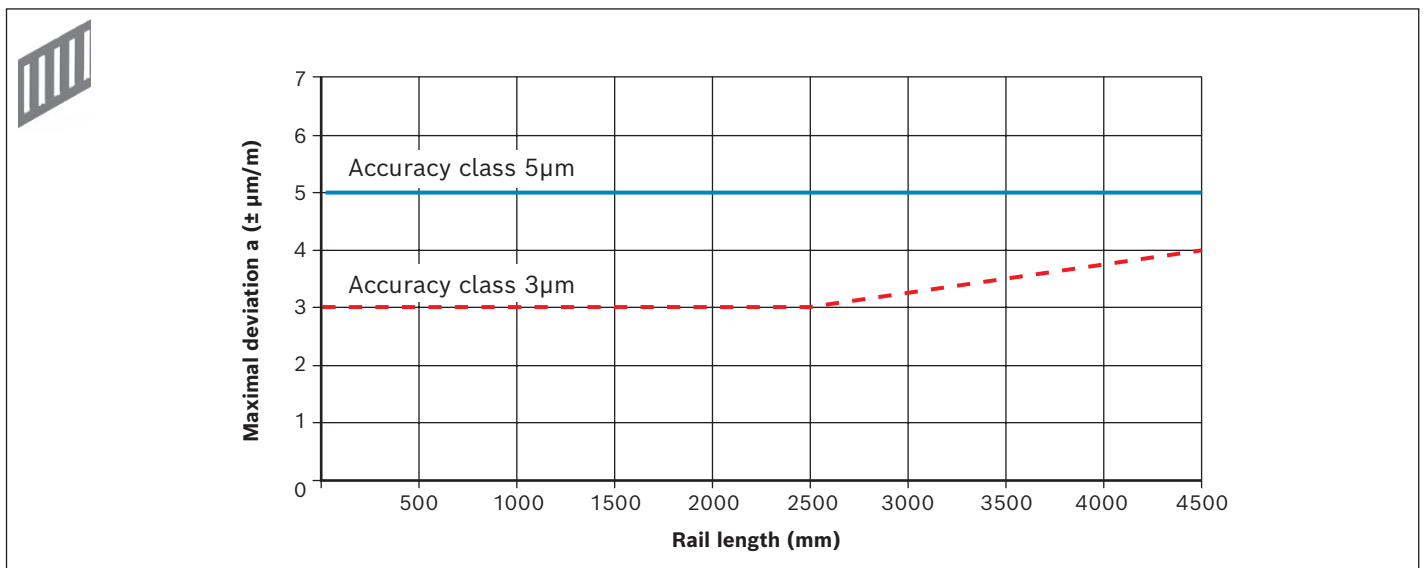

#### ▼ Example: Measurement curves of an IMS rail

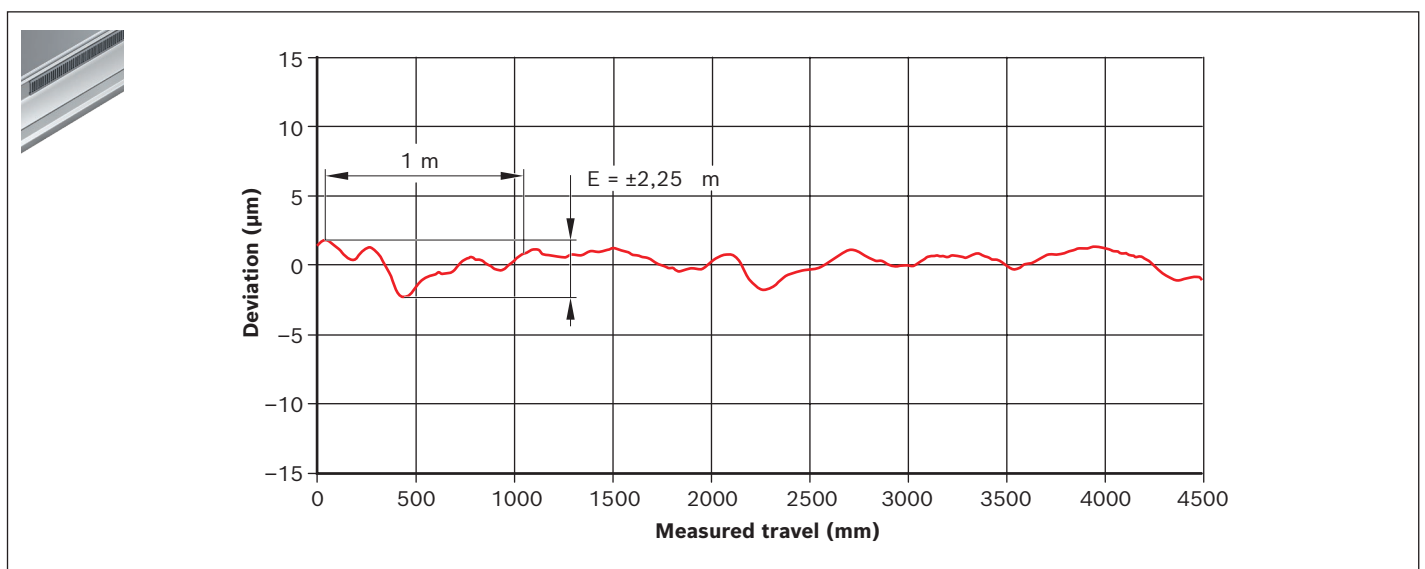

## Description and technical data of overall system

### System accuracy (IMS-I / IMS-A)

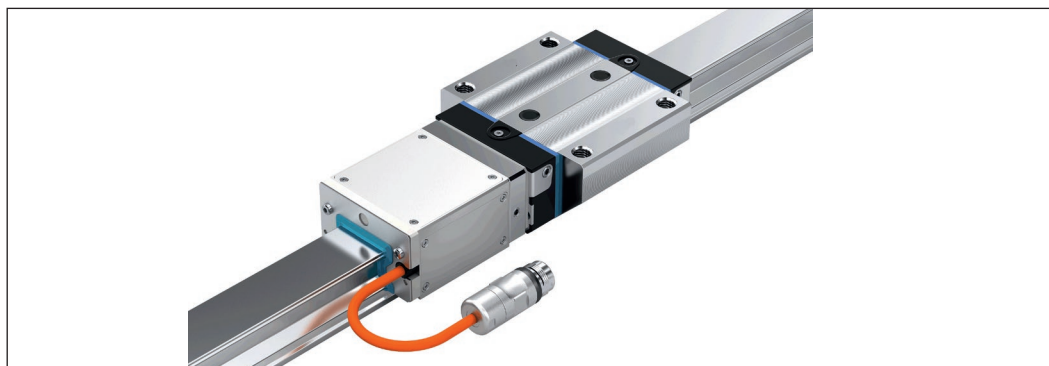

Scale	Scanner	
	Interpolation accuracy ( $\mu\text{m}$ )	Repeatability ( $\mu\text{m}$ )
Accuracy class 3 $\mu\text{m}$	$\pm 0.75$	$\pm 0.25$
Accuracy class 5 $\mu\text{m}$	$\pm 0.75$	$\pm 0.25$

The precise accuracy of the scale is provided in the included measurement report. To determine the accuracy of the system, the accuracy classes of the scale, the interpolation accuracy and repeatability are to be added together.

IMS-I				
Interface (signal)	I1 (1V <sub>SS</sub> )	I2 (TTL 1 $\mu\text{m}$ )	I3 (TTL 5 $\mu\text{m}$ )	I4 (TTL 10 $\mu\text{m}$ )
Resolution of the TTL signal ( $\mu\text{m}$ )	–	1	5	10
Dissolvability of the 1 V <sub>SS</sub> / 40 $\mu\text{m}$ signal ( $\mu\text{m}$ )	0.025	–	–	–

IMS-A							
Interface (signal)	HF	DQ	FN	S1	S2	S3	S4
Resolution of the digital interface ( $\mu\text{m}$ )	1.25	0.025	0.025	10	1	0.25	0.125
Dissolvability of the 1 V <sub>SS</sub> / 40 $\mu\text{m}$ signal ( $\mu\text{m}$ )	0.025	–	–	0.025	0.025	0.025	0.025

### Technical data of overall system

	Ball Rail System	Roller Rail System	Comment
Maximum traversing speed	5 m/s	4 m/s	
Acceleration $a_{\text{max}}$	500 m/s <sup>2</sup>	150 m/s <sup>2</sup>	
Shock	500 m/s <sup>2</sup> / 11 ms		EN 60068-2-27
Vibration	100 m/s <sup>2</sup> (57Hz - 200Hz) 1,5 mm <sub>p-p</sub> (10Hz - 57Hz)		EN 60068-2-6
Protection class	IP67		EN 60529, tested with metalworking fluid Curtis S90
EMC	EN 61326-1 EN 61000-6-2 / EN 61000-6-3		CE-marking
RoHS compliant	yes		
UL compliant	yes		

## Thermal behavior

The thermal behavior of the IMS will be determined by two components:

- 1 IMS guide rail -> with integrated steel scale.
- 2 IMS runner block -> runner block with attached scanner and sensors.

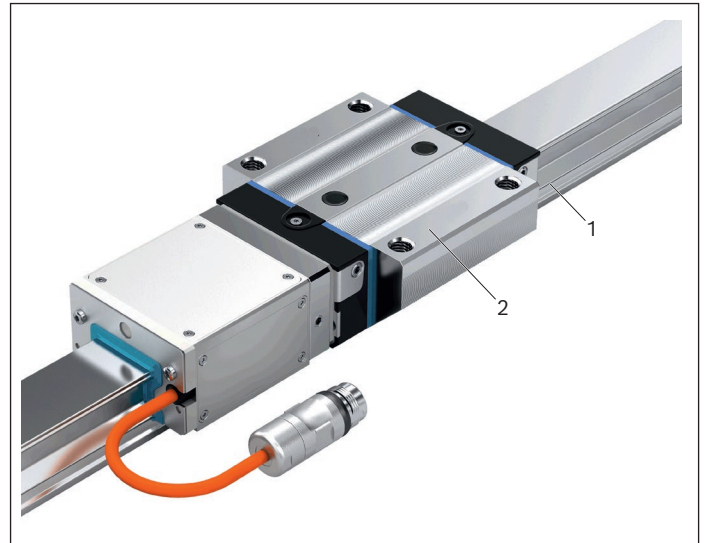

IMS guide rail (coefficient of linear expansion):

Profile rail:  $\alpha_{\text{therm}} = 11 \times 10^{-6} \text{K}^{-1}$

scale:  $\alpha_{\text{therm}} = 11 \times 10^{-6} \text{K}^{-1}$



Influence basic design:

Acceptance: Fitting the guide rail on an ideally rigid base.

The base determines the longitudinal expansion of the

IMS rail:  $\alpha_{\text{therm}} = \alpha_{\text{therm}} - \text{base}$

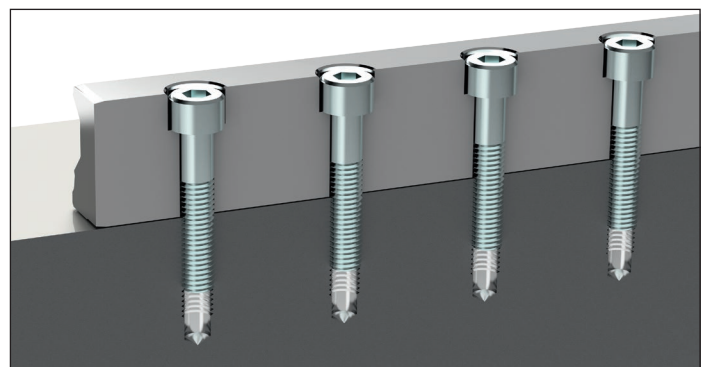

# Product overview and type designation, ball runner blocks

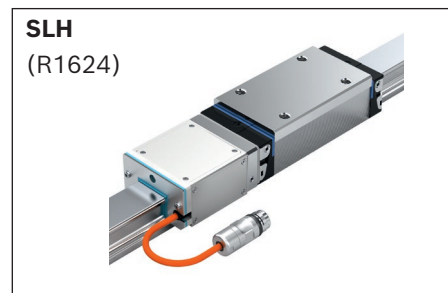
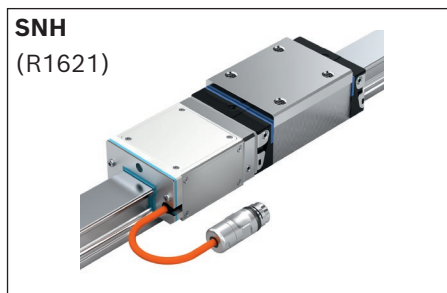
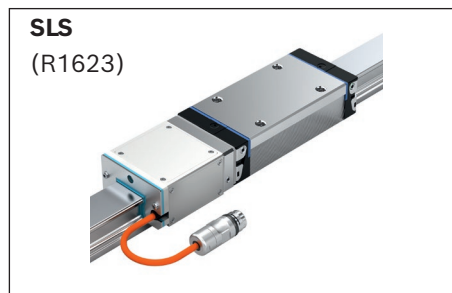
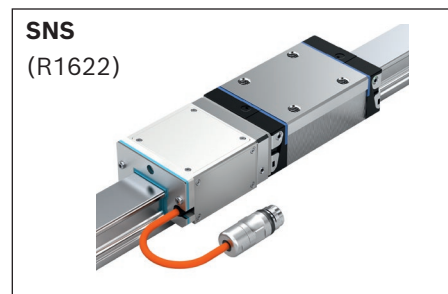
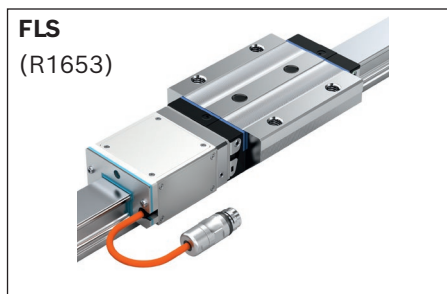
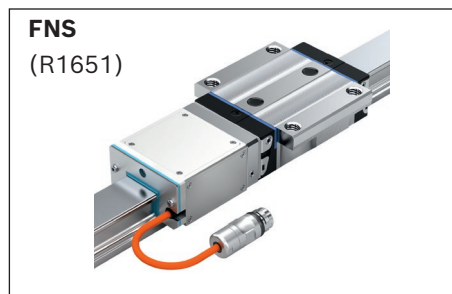

## Available versions

Ball runner blocks	Ball chain	Seal	Size																								
			20					25					30					35					45				
			P		S			P		S			P		S			P		S			P		S		
			C1	C2	C1	C2	C3	C1	C2	C1	C2	C3	C1	C2	C1	C2	C3	C1	C2	C1	C2	C3	C1	C2	C1	C2	C3
FNS	0 / R	SS	✓	✓	✓	✓	✓	✓	✓	✓	✓	✓	✓	✓	✓	✓	✓	✓	✓	✓	✓	✓	✓	✓	✓		
	0 / R	LS	✓		✓				✓		✓				✓		✓										
	0 / R	DS	✓	✓	✓	✓	✓	✓	✓	✓	✓	✓	✓	✓	✓	✓	✓	✓	✓	✓	✓	✓	✓	✓	✓		
FLS	0 / R	SS	✓	✓	✓	✓	✓	✓	✓	✓	✓	✓	✓	✓	✓	✓	✓	✓	✓	✓	✓	✓	✓	✓	✓		
	0 / R	LS	✓		✓				✓		✓				✓		✓										
	0 / R	DS	✓	✓	✓	✓	✓	✓	✓	✓	✓	✓	✓	✓	✓	✓	✓	✓	✓	✓	✓	✓	✓	✓	✓		
SNS	0 / R	SS	✓	✓				✓	✓					✓	✓								✓	✓			
	0 / R	LS	✓					✓						✓													
	0 / R	DS	✓	✓				✓	✓					✓	✓								✓	✓			
SLS	0 / R	SS	✓	✓				✓	✓					✓	✓								✓	✓			
	0 / R	LS	✓					✓						✓													
	0 / R	DS	✓	✓				✓	✓					✓	✓								✓	✓			
SNH	0 / R	SS						✓	✓					✓	✓								✓	✓			
	0 / R	LS						✓						✓													
	0 / R	DS						✓	✓					✓	✓								✓	✓			
SLH	0 / R	SS						✓	✓					✓	✓								✓	✓			
	0 / R	LS						✓						✓													
	0 / R	DS						✓	✓					✓	✓								✓	✓			

✓ = Available versions



**Type designation ball runner block with IMS (example)**

I	M	S	2	x	-	K	W	D	-	0	2	0	-	F	N	S	-	C	2	-	P	-	S	S	-	R	-	R	-	xx	-	A	-	1	0	0	-	D
										1				2				3				4		5		6		7		8		9		10				11

I for IMS-I (incremental)

A for IMS-A (absolute)

see option interface

**1 Size**

Feature	Designation
020	Size 20
025	Size 25
030	Size 30
035	Size 35
045	Size 45

**2 Format**

Feature	Designation
FNS	Flanged, normal, standard height
FLS	Flanged, long, standard height
SNS	Slimline, normal, standard height
SLS	Slimline, long, standard height
SNH	Slimline, normal, high
SLH	Slimline, long, high

**3 Preload class**

Feature	Designation
C1	Preload class C1
C2	Preload class C2
C3	Preload class C3

**4 Accuracy class**

Feature	Designation
P	Precision
S	Super precision (SP)

**5 Seal**

Feature	Designation
SS	Standard seal
LS	Low-friction seal
DS	Double-lip seal

**6 Ball chain**

Feature	Designation
0	Without ball chain
R	with ball chain

**7 Scanner mounting side**

Feature	Designation
R	Right-hand
L	Left-hand

**8 Interface**

IMS-I		IMS-A	
Feature	Designation	Feature	Designation
I 1	1 V <sub>SS</sub> 40 μm	HF	HIPERFACE®
I 2	TTL 1 μm	DQ	DRIVE-CLiQ
I 3	TTL 5 μm	FN	FANUC αi
I 4	TTL 10 μm	S1	SSI 10 μm
		S2	SSI 1 μm
		S3	SSI 0.25 μm
		S4	SSI 0.125 μm

**9 Connector type**

Feature	Designation
A	RGS 1722
B	RGS 1714
C	M12 / 8pole (only DRIVE-CLiQ)
D	M23 / 17pin (FANUC only)

**10 Cable length**

Feature	Designation
100	1.0 meter



**11 Documentation**

Feature	Designation
D	Standard documentation

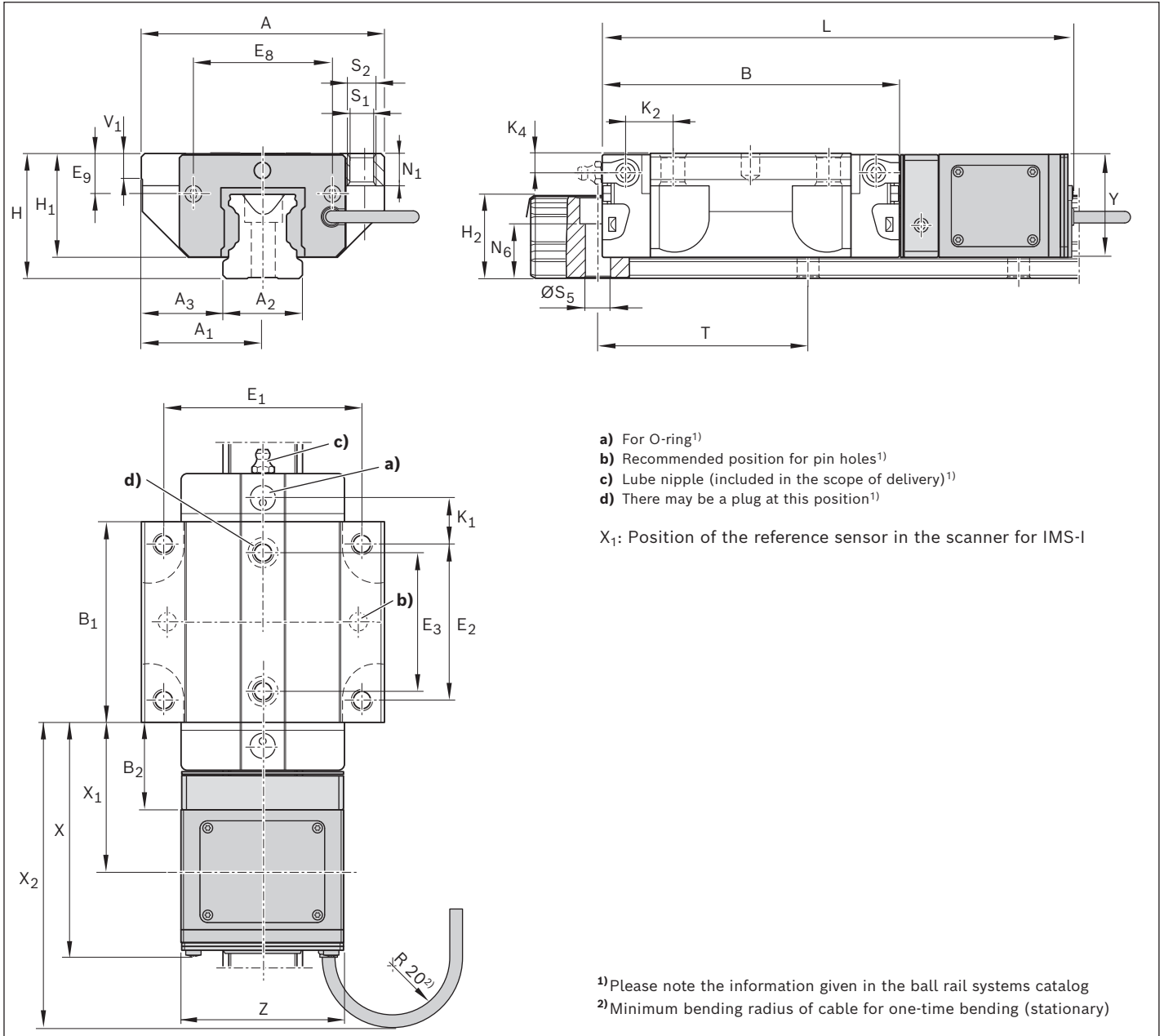



**Technical data**

Size	Weight (kg)	Max. permissible load <sup>3)</sup> (N) for preload class	Max. permissible moment load <sup>3)</sup> (Nm) for preload class		
			 		
	m	C1/C2/C3	C1	C2	C3
20	0.67	9 400	42	53	65
25	0.91	11 400	66	73	90
30	1.42	15 850	106	117	145
35	2.00	20 950	125	178	220
45	3.58	34 050	216	360	445

<sup>3)</sup>Values for ball runner block without ball chain with assembled scanner. Compliance with these values will ensure safe functioning of the application. Exceeding these values can lead to destruction of the equipment. For the life expectancy calculation, the values from the “Ball rail systems” catalog must be used. Values for ball runner block with ball chain are available on request.

# Ball runner blocks FLS

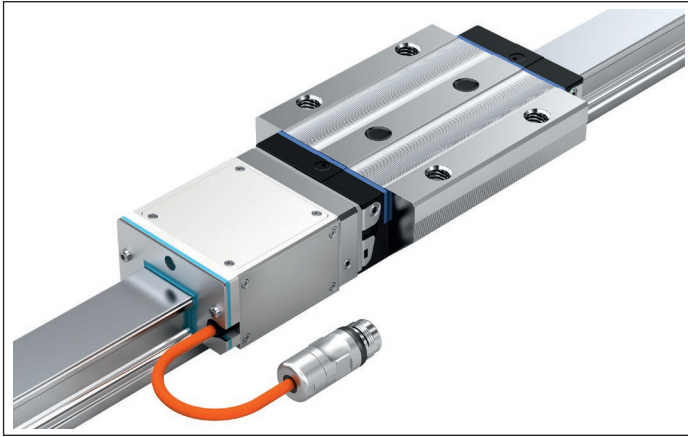

## Dynamic characteristics

See the section “Description and technical data of overall system”.

## Notes:

- ▶ With initial greasing (sufficient for mounting and start-up). For more details on lubrication, please refer to the “Maintenance Instructions” section.
- ▶ Delivery: Ball runner block with ready-mounted adapter plate and ready-mounted scanner. A lube nipple is included in the delivery.
- ▶ Note mounting instructions. See the chapter entitled “Mounting instructions”.
- ▶ For ordering examples, see the “Ordering examples” section.

## Available versions

FLS	Ball chain	Seal	Size																						
			20			25			30			35			45										
			P	S		P	S		P	S		P	S		P	S									
C1	C2	C3	C1	C2	C3	C1	C2	C3	C1	C2	C3	C1	C2	C3	C1	C2	C3								
0/R	SS		✓	✓	✓	✓	✓	✓	✓	✓	✓	✓	✓	✓	✓	✓	✓	✓	✓	✓	✓	✓	✓	✓	✓
0/R	LS		✓		✓			✓		✓			✓		✓										
0/R	DS		✓	✓	✓	✓	✓	✓	✓	✓	✓	✓	✓	✓	✓	✓	✓	✓	✓	✓	✓	✓	✓	✓	✓

✓ = Available versions

## Dimensions (mm)

Size	A	A <sub>1</sub>	A <sub>2</sub>	A <sub>3</sub>	B	B <sub>1</sub>	B <sub>2</sub>	E <sub>1</sub>	E <sub>2</sub>	E <sub>3</sub>	E <sub>8</sub>	E <sub>9</sub>	H	H <sub>1</sub>	H <sub>2</sub> <sup>1</sup>	H <sub>2</sub> <sup>2</sup>	K <sub>1</sub>	K <sub>2</sub>	K <sub>4</sub>
20	63	31.5	20	21.5	91.0	65.6	23.45	53	40	35	32.5	7.30	30	25.35	20.75	20.55	19.80	19.80	3.35
25	70	35.0	23	23.5	107.9	79.5	24.95	57	45	40	38.3	11.50	36	29.90	24.45	24.25	23.30	24.45	5.50
30	90	45.0	28	31.0	119.7	89.4	27.40	72	52	44	48.4	14.60	42	35.35	28.55	28.35	25.00	26.70	6.05
35	100	50.0	34	33.0	139.0	105.5	29.00	82	62	52	58.0	17.35	48	40.40	32.15	31.85	28.75	30.25	6.90
45	120	60.0	45	37.5	174.1	133.5	32.55	100	80	60	69.8	20.90	60	50.30	40.15	39.85	35.50	37.50	8.20

Size	L	N1	N <sub>6</sub> <sup>±0.5</sup>	S <sub>1</sub>	S <sub>2</sub>	∅S <sub>5</sub>	T	V <sub>1</sub>	X	X <sub>1</sub>	X <sub>2</sub>	Y	Z
20	171.9	7.7	13.2	5.3	M6	6	60	6.0	93.10	53.45	118.10	24.93	43
25	188.8	9.3	15.2	6.7	M8	7	60	7.5	94.60	54.95	119.60	29.43	47
30	202.6	11.0	17.0	8.5	M10	9	80	7.0	97.55	57.40	122.55	34.50	59
35	222.2	12.0	20.5	8.5	M10	9	80	8.0	99.45	59.00	124.45	39.50	69
45	258.5	15.0	23.5	10.4	M12	14	105	10.0	104.20	62.55	129.20	49.50	85

<sup>1</sup>)Dimension H<sub>2</sub> with cover strip

<sup>2</sup>)Dimension H<sub>2</sub> without cover strip

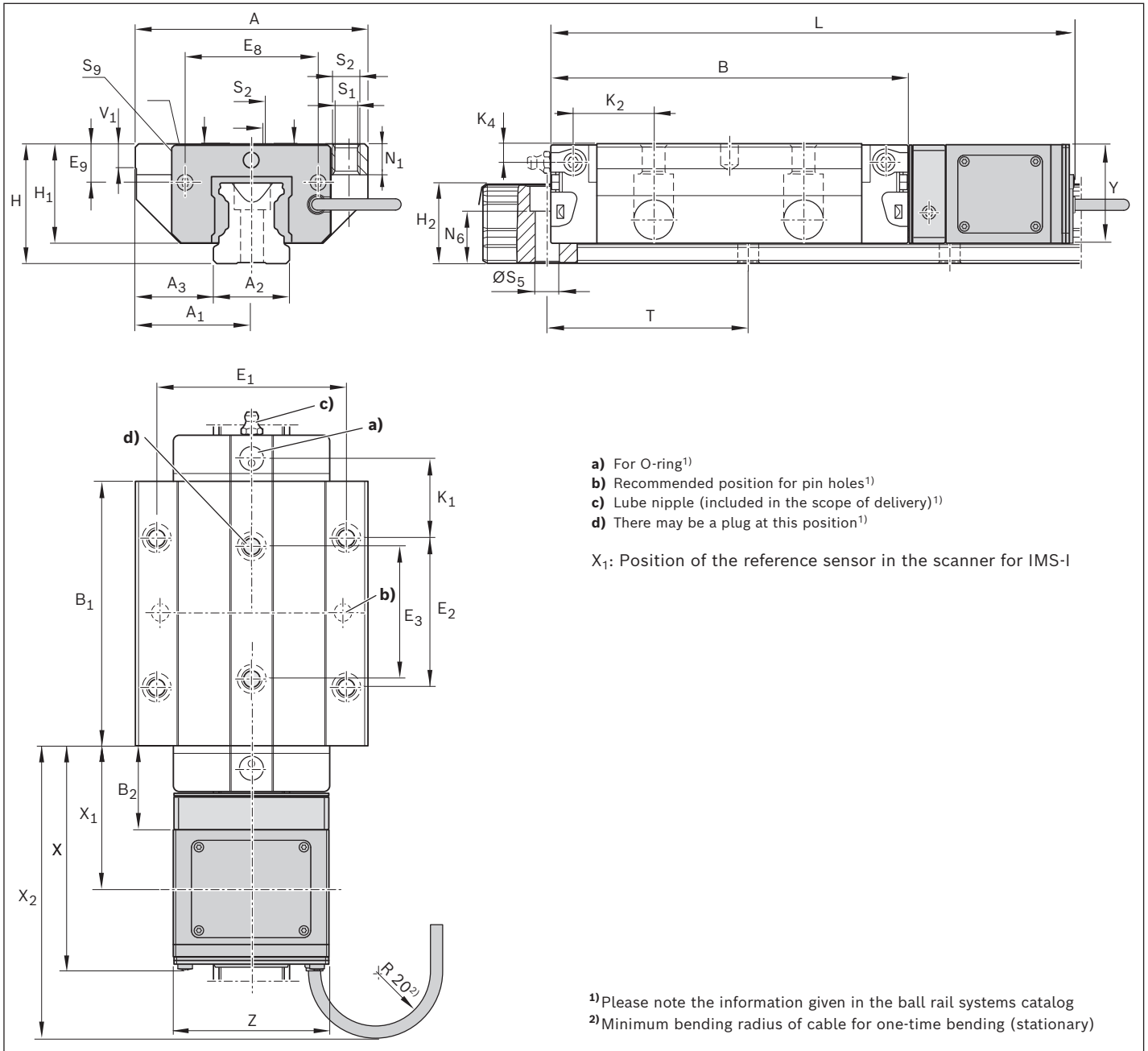

**Technical data**

Size	Weight (kg)	Max. permissible load <sup>3)</sup> (N) for preload class	Max. permissible moment load <sup>3)</sup> (Nm) for preload class		
	m	C1/C2/C3	C1	C2	C3
20	0.77	12 200	113	126	155
25	1.16	15 200	174	174	215
30	1.82	20 000	279	279	345
35	2.65	27 800	486	486	600
45	4.88	45 200	889	988	1220

<sup>3)</sup>Values for ball runner block without ball chain with assembled scanner. Compliance with these values will ensure safe functioning of the application. Exceeding these values can lead to destruction of the equipment. For the life expectancy calculation, the values from the “Ball rail systems” catalog must be used. Values for ball runner block with ball chain are available on request.

## Ball runner blocks SNS

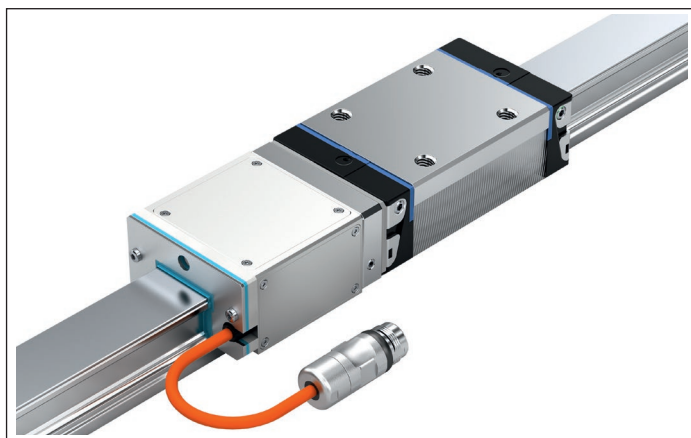

### Dynamic characteristics

See the section “Description and technical data of overall system”.

### Notes:

- ▶ With initial greasing (sufficient for mounting and start-up). For more details on lubrication, please refer to the “Maintenance instructions” section.
- ▶ Delivery: Ball runner block with ready-mounted adapter plate and ready-mounted scanner. A lube nipple is included in the delivery.
- ▶ Note mounting instructions. See the chapter entitled “Mounting instructions”.
- ▶ For ordering examples, see the “Ordering examples” section.

### Available versions

SNS	Ball chain	Seal	Size															
			20		25		30		35		45							
			P	C1	C2	P	C1	C2	P	C1	C2	P	C1	C2				
	0/R	SS	✓	✓	✓	✓	✓	✓	✓	✓	✓	✓	✓	✓	✓	✓	✓	✓
	0/R	LS	✓		✓		✓		✓		✓		✓					
	0/R	DS	✓	✓	✓	✓	✓	✓	✓	✓	✓	✓	✓	✓	✓	✓	✓	✓

✓ = Available versions

### Dimensions (mm)

Size	A	A <sub>1</sub>	A <sub>2</sub>	A <sub>3</sub>	B	B <sub>1</sub>	B <sub>2</sub>	E <sub>1</sub>	E <sub>2</sub>	E <sub>8</sub>	E <sub>9</sub>	H	H <sub>1</sub>	H <sub>2</sub> <sup>1</sup>	H <sub>2</sub> <sup>2</sup>	K <sub>1</sub>	K <sub>2</sub>	K <sub>4</sub>
20	44	22	20	12.0	75.0	49.6	23.45	32	36	32.5	7.30	30	25.35	20.75	20.55	13.80	13.80	3.35
25	48	24	23	12.5	86.2	57.8	24.95	35	35	38.3	11.50	36	29.90	24.45	24.25	17.45	18.60	5.50
30	60	30	28	16.0	97.7	67.4	27.40	40	40	48.4	14.60	42	35.35	28.55	28.35	20.00	21.70	6.05
35	70	35	34	18.0	110.5	77.0	29.00	50	50	58.0	17.35	48	40.40	32.15	31.85	20.50	22.00	6.90
45	86	43	45	20.5	137.6	97.0	32.55	60	60	69.8	20.90	60	50.30	40.15	39.85	27.30	29.30	8.20



Size	L	N <sub>3</sub>	N <sub>6</sub> <sup>+0.5</sup>	S <sub>2</sub>	∅S <sub>5</sub>	T	V <sub>1</sub>	X	X <sub>1</sub>	X <sub>2</sub>	Y	Z
20	155.9	7.5	13.2	M5	6	60	6.0	93.10	53.45	118.10	24.93	43
25	167.1	9.0	15.2	M6	7	60	7.5	94.60	54.95	119.60	29.43	47
30	180.6	12.0	17.0	M8	9	80	7.0	97.55	57.40	122.55	34.50	59
35	193.7	13.0	20.5	M8	9	80	8.0	99.45	59.00	124.45	39.50	69
45	222.0	18.0	23.5	M10	14	105	10.0	104.20	62.55	129.20	49.50	85

<sup>1</sup>)Dimension H<sub>2</sub> with cover strip

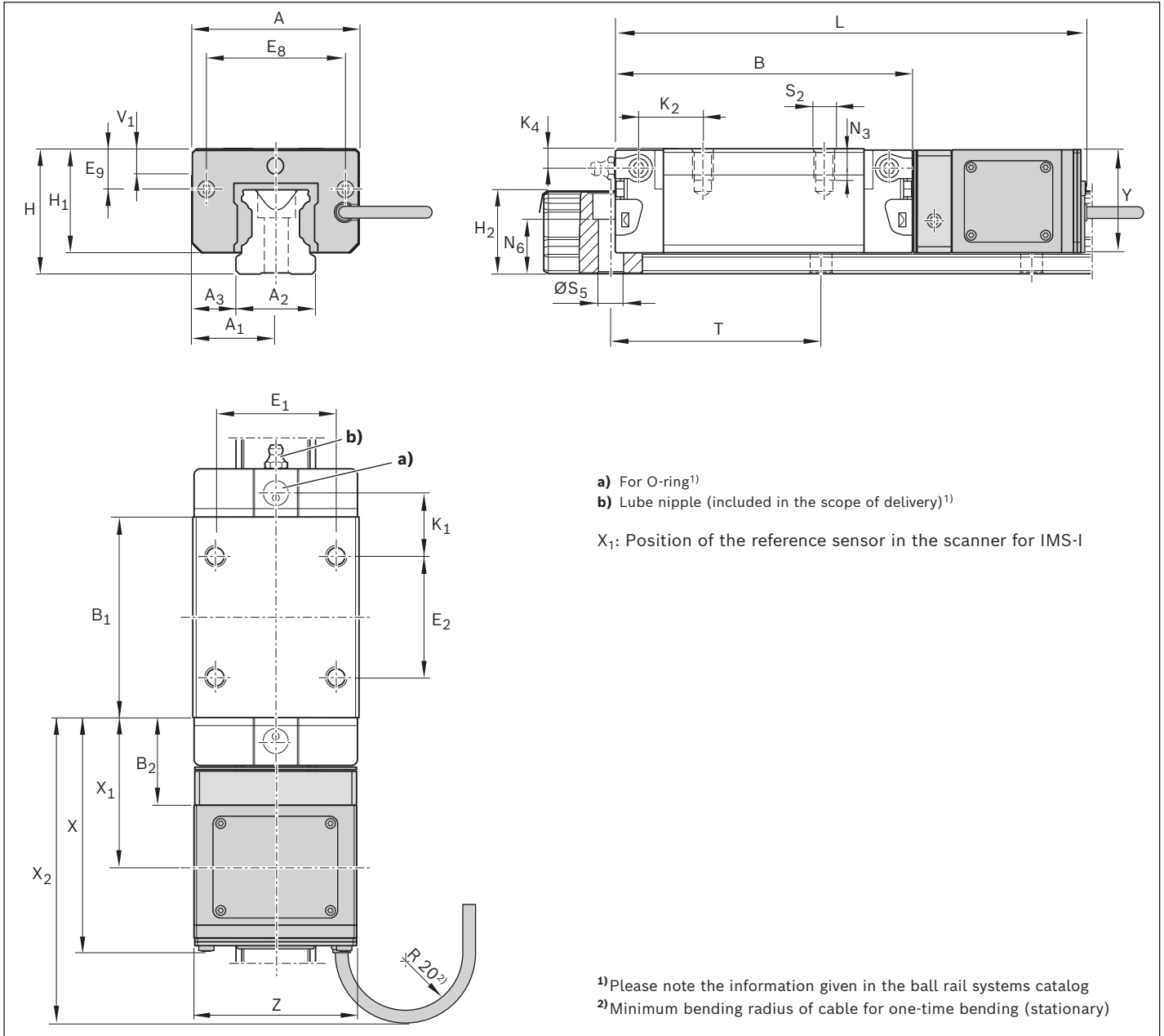
<sup>2</sup>)Dimension H<sub>2</sub> without cover strip



**Technical data**

Size	Weight (kg)	Max. permissible load <sup>3)</sup> (N) for preload class	Max. permissible moment load <sup>3)</sup> (Nm) for preload class		
					
	<b>m</b>		<b>C1/C2</b>	<b>C1</b>	<b>C2</b>
<b>20</b>	0.57		9 400	42	53
<b>25</b>	0.76		11 400	51	73
<b>30</b>	1.17		15 850	94	117
<b>35</b>	1.65		20 950	125	178
<b>45</b>	2.98		34 050	180	288

<sup>3)</sup>Values for ball runner block without ball chain with assembled scanner. Compliance with these values will ensure safe functioning of the application. Exceeding these values can lead to destruction of the equipment. For the life expectancy calculation, the values from the “Ball rail systems” catalog must be used. Values for ball runner block with ball chain are available on request.

## Ball runner blocks SLS

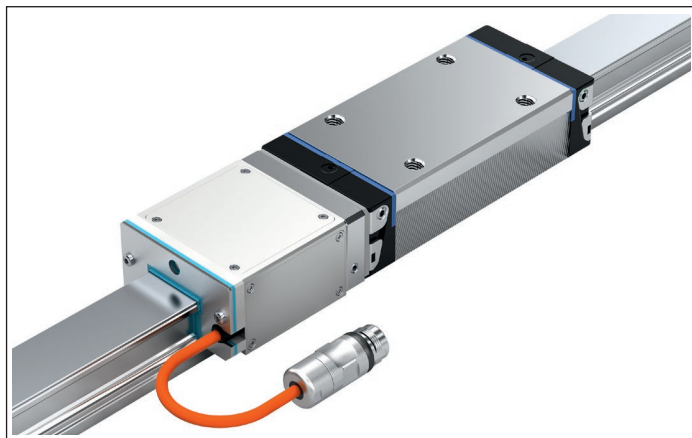

### Dynamic characteristics

See the section “Description and technical data of overall system”.

### Notes:

- ▶ With initial greasing (sufficient for mounting and start-up). For more details on lubrication, please refer to the “Maintenance instructions” section.
- ▶ Delivery: Ball runner block with ready-mounted adapter plate and ready-mounted scanner. A lube nipple is included in the delivery.
- ▶ Note mounting instructions. See the chapter entitled “Mounting instructions”.
- ▶ For ordering examples, see the “Ordering examples” section.

### Available versions

SLS	Ball chain	Seal	Size															
			20		25		30		35		45							
			P	C1	C2	P	C1	C2	P	C1	C2	P	C1	C2				
	0/R	SS	✓	✓	✓	✓	✓	✓	✓	✓	✓	✓	✓	✓	✓	✓	✓	✓
	0/R	LS	✓			✓			✓			✓						
	0/R	DS	✓	✓	✓	✓	✓	✓	✓	✓	✓	✓	✓	✓	✓	✓	✓	✓

✓ = Available versions

### Dimensions (mm)

Size	A	A <sub>1</sub>	A <sub>2</sub>	A <sub>3</sub>	B	B <sub>1</sub>	B <sub>2</sub>	E <sub>1</sub>	E <sub>2</sub>	E <sub>8</sub>	E <sub>9</sub>	H	H <sub>1</sub>	H <sub>2</sub> <sup>1</sup>	H <sub>2</sub> <sup>2</sup>	K <sub>1</sub>	K <sub>2</sub>	K <sub>4</sub>
20	44	22	20	12.0	91.0	65.6	23.45	32	50	32.5	7.30	30	25.35	20.75	20.55	14.80	14.80	3.35
25	48	24	23	12.5	107.9	79.5	24.95	35	50	38.3	11.50	36	29.90	24.45	24.25	20.80	21.95	5.50
30	60	30	28	16.0	119.7	89.4	27.40	40	60	48.4	14.60	42	35.35	28.55	28.35	21.00	22.70	6.05
35	70	35	34	18.0	139.0	105.5	29.00	50	72	58.0	17.35	48	40.40	32.15	31.85	23.75	25.25	6.90
45	86	43	45	20.5	174.1	133.5	32.55	60	80	69.8	20.90	60	50.30	40.15	39.85	35.50	37.50	8.20

Size	L	N <sub>3</sub>	N <sub>6</sub> <sup>±0.5</sup>	S <sub>2</sub>	∅S <sub>5</sub>	T	V <sub>1</sub>	X	X <sub>1</sub>	X <sub>2</sub>	Y	Z
20	171.9	7.5	13.2	M5	6	60	6.0	93.10	53.45	118.10	24.93	43
25	188.8	9.0	15.2	M6	7	60	7.5	94.60	54.95	119.60	29.43	47
30	202.6	12.0	17.0	M8	9	80	7.0	97.55	57.40	122.55	34.50	59
35	222.2	13.0	20.5	M8	9	80	8.0	99.45	59.00	124.45	39.50	69
45	258.5	18.0	23.5	M10	14	105	10.0	104.20	62.55	129.20	49.50	85

<sup>1</sup>)Dimension H<sub>2</sub> with cover strip

<sup>2</sup>)Dimension H<sub>2</sub> without cover strip



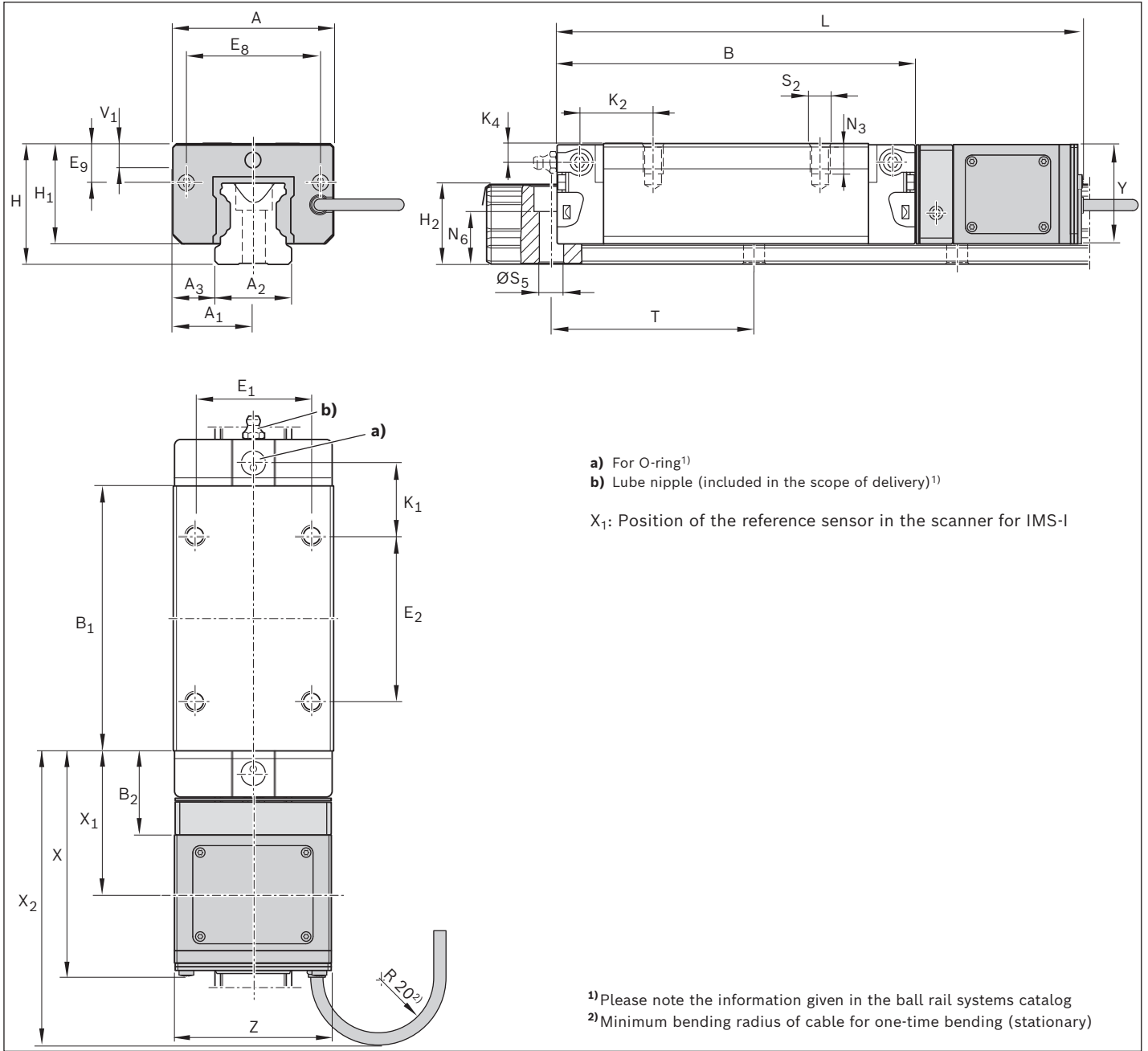

**Technical data**

Size	Weight (kg)	Max. permissible load <sup>3)</sup> (N) for preload class	Max. permissible moment load <sup>3)</sup> (Nm) for preload class		
			$M_{Z \max}$ C1	C2	
	<b>m</b>		<b>C1/C2</b>	<b>C1</b>	<b>C2</b>
20	0.67		12 200	113	126
25	0.91		15 200	174	174
30	1.42		20 000	279	279
35	2.10		27 800	437	486
45	3.78		45 200	692	988

<sup>3)</sup>Values for ball runner block without ball chain with assembled scanner. Compliance with these values will ensure safe functioning of the application. Exceeding these values can lead to destruction of the equipment. For the life expectancy calculation, the values from the “Ball rail systems” catalog must be used. Values for ball runner block with ball chain are available on request.

# Ball runner blocks SNH

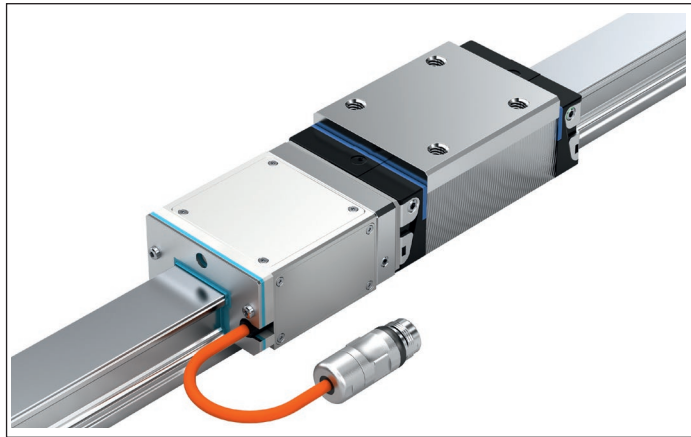

## Dynamic characteristics

See the section “Description and technical data of overall system”.

## Notes:

- ▶ With initial greasing (sufficient for mounting and start-up). For more details on lubrication, please refer to the “Maintenance instructions” section.
- ▶ Delivery: Ball runner block with ready-mounted adapter plate and ready-mounted scanner. A lube nipple is included in the delivery.
- ▶ Note mounting instructions. See the chapter entitled “Mounting instructions”.
- ▶ For ordering examples, see the “Ordering examples” section.

## Available versions

SNH	Ball chain	Seal	Size								
			25		30		35		45		
			P	C1	C2	P	C1	C2	P	C1	C2
	0/R	SS	✓	✓	✓	✓	✓	✓	✓	✓	✓
	0/R	LS	✓			✓			✓		
	0/R	DS	✓	✓	✓	✓	✓	✓	✓	✓	✓

✓ = Available versions

## Dimensions (mm)

Size	A	A <sub>1</sub>	A <sub>2</sub>	A <sub>3</sub>	B	B <sub>1</sub>	B <sub>2</sub>	E <sub>1</sub>	E <sub>2</sub>	E <sub>8</sub>	E <sub>9</sub>	H	H <sub>1</sub>	H <sub>2</sub> <sup>1</sup>	H <sub>2</sub> <sup>2</sup>	K <sub>1</sub>	K <sub>2</sub>	K <sub>3</sub>	K <sub>4</sub>
25	48	24	23	12.5	86.2	57.8	24.95	35	35	38.3	15.50	40	33.90	24.45	24.25	17.45	18.6	9.50	9.50
30	60	30	28	16.0	97.7	67.4	27.40	40	40	48.4	17.60	45	38.35	28.55	28.35	20.00	21.7	9.05	9.05
35	70	35	34	18.0	110.5	77.0	29.00	50	50	58.0	24.35	55	47.40	32.15	31.85	20.50	22.0	13.90	13.90
45	86	43	45	20.5	137.6	97.0	32.55	60	60	69.8	30.90	70	60.30	40.15	39.85	27.30	29.3	18.20	18.20



Size	L	N <sub>3</sub>	N <sub>6</sub> <sup>±0.5</sup>	S <sub>2</sub>	∅S <sub>5</sub>	T	V <sub>1</sub>	X	X <sub>1</sub>	X <sub>2</sub>	Y	Z
25	167.1	9.0	15.2	M6	7	60	7.5	94.60	54.95	119.60	29.43	47
30	180.6	12.0	17.0	M8	9	80	7.0	97.55	57.40	122.55	34.50	59
35	193.7	13.0	20.5	M8	9	80	8.0	99.45	59.00	124.45	39.50	69
45	222.0	18.0	23.5	M10	14	105	10.0	104.20	62.55	129.20	49.50	85

<sup>1</sup>) Dimension H<sub>2</sub> with cover strip

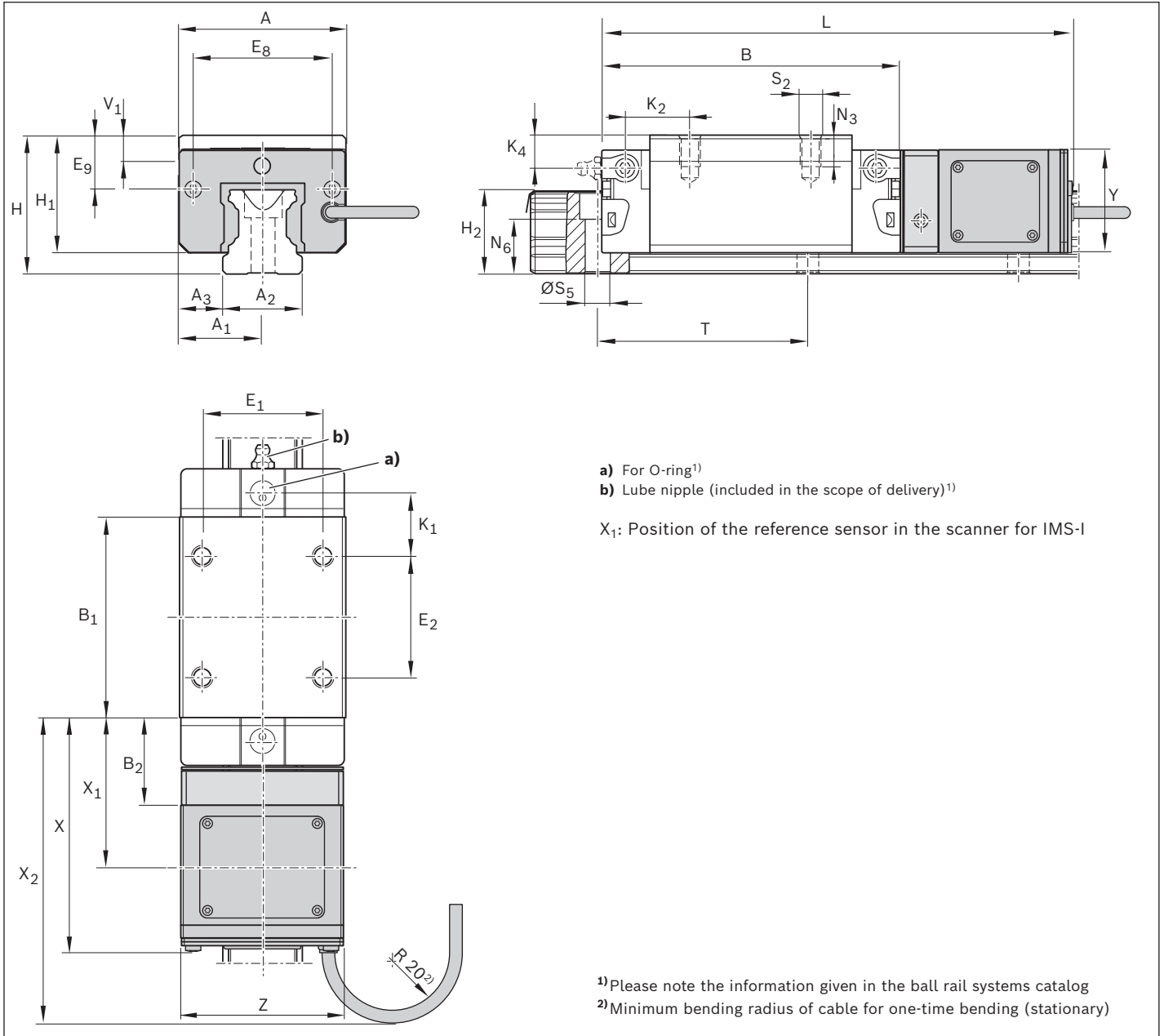
<sup>2</sup>) Dimension H<sub>2</sub> without cover strip



**Technical data**

Size	Weight (kg)	Max. permissible load <sup>3)</sup> (N) for preload class	Max. permissible moment load <sup>3)</sup> (Nm) for preload class	
			 <b>M<sub>Z</sub> max</b> 	
	<b>m</b>	<b>C1/C2</b>	<b>C1</b>	<b>C2</b>
<b>25</b>	0.86	11 400	66	73
<b>30</b>	1.27	15 850	106	117
<b>35</b>	1.95	20 950	143	178
<b>45</b>	3.58	34 050	324	252

<sup>3)</sup>Values for ball runner block without ball chain with assembled scanner. Compliance with these values will ensure safe functioning of the application. Exceeding these values can lead to destruction of the equipment. For the life expectancy calculation, the values from the "Ball rail systems" catalog must be used. Values for ball runner block with ball chain are available on request.

## Ball runner blocks SLH

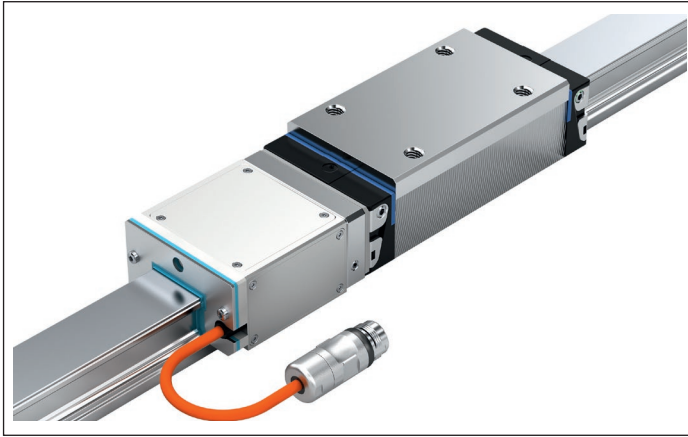

### Dynamic characteristics

See the section “Description and technical data of overall system”.

### Notes:

- ▶ With initial greasing (sufficient for mounting and start-up). For more details on lubrication, please refer to the “Maintenance instructions” section.
- ▶ Delivery: Ball runner block with ready-mounted adapter plate and ready-mounted scanner. A lube nipple is included in the delivery.
- ▶ Note mounting instructions. See the chapter entitled “Mounting instructions”.
- ▶ For ordering examples, see the “Ordering examples” section.

### Available versions

SLH	Ball chain	Seal	Size							
			25		30		35		45	
			P	C1	P	C2	P	C2	P	C2
	0/R	SS	✓	✓	✓	✓	✓	✓	✓	✓
	0/R	LS	✓		✓		✓			
	0/R	DS	✓	✓	✓	✓	✓	✓	✓	✓

✓ = Available versions

### Dimensions (mm)

Size	A	A <sub>1</sub>	A <sub>2</sub>	A <sub>3</sub>	B	B <sub>1</sub>	B <sub>2</sub>	E <sub>1</sub>	E <sub>2</sub>	E <sub>8</sub>	E <sub>9</sub>	H	H <sub>1</sub>	H <sub>2</sub> <sup>1</sup>	H <sub>2</sub> <sup>2</sup>	K <sub>1</sub>	K <sub>2</sub>	K <sub>4</sub>
25	48	24	23	12.5	107.9	79.5	24.95	35	50	38.3	15.50	40	33.90	24.45	24.25	20.80	21.95	9.50
30	60	30	28	16.0	119.7	89.4	27.40	40	60	48.4	17.60	45	38.35	28.55	28.35	21.00	22.70	9.05
35	70	35	34	18.0	139.0	105.5	29.00	50	72	58.0	24.35	55	47.40	32.15	31.85	23.75	25.25	13.90
45	86	43	45	20.5	174.1	133.5	32.55	60	80	69.8	30.90	70	60.30	40.15	39.85	35.50	37.50	18.20

Size	L	N <sub>3</sub>	N <sub>6</sub> <sup>±0.5</sup>	S <sub>2</sub>	∅S <sub>5</sub>	T	V <sub>1</sub>	X	X <sub>1</sub>	X <sub>2</sub>	Y	Z
25	188.8	9	15.2	M6	7	60	7.5	94.60	54.95	119.60	29.43	47
30	202.6	12	17.0	M8	9	80	7.0	97.55	57.40	122.55	34.50	59
35	222.2	13	20.5	M8	9	80	8.0	99.45	59.00	124.45	39.50	69
45	258.5	18	23.5	M10	14	105	10.0	104.20	62.55	129.20	49.50	85

<sup>1</sup>)Dimension H<sub>2</sub> with cover strip

<sup>2</sup>)Dimension H<sub>2</sub> without cover strip

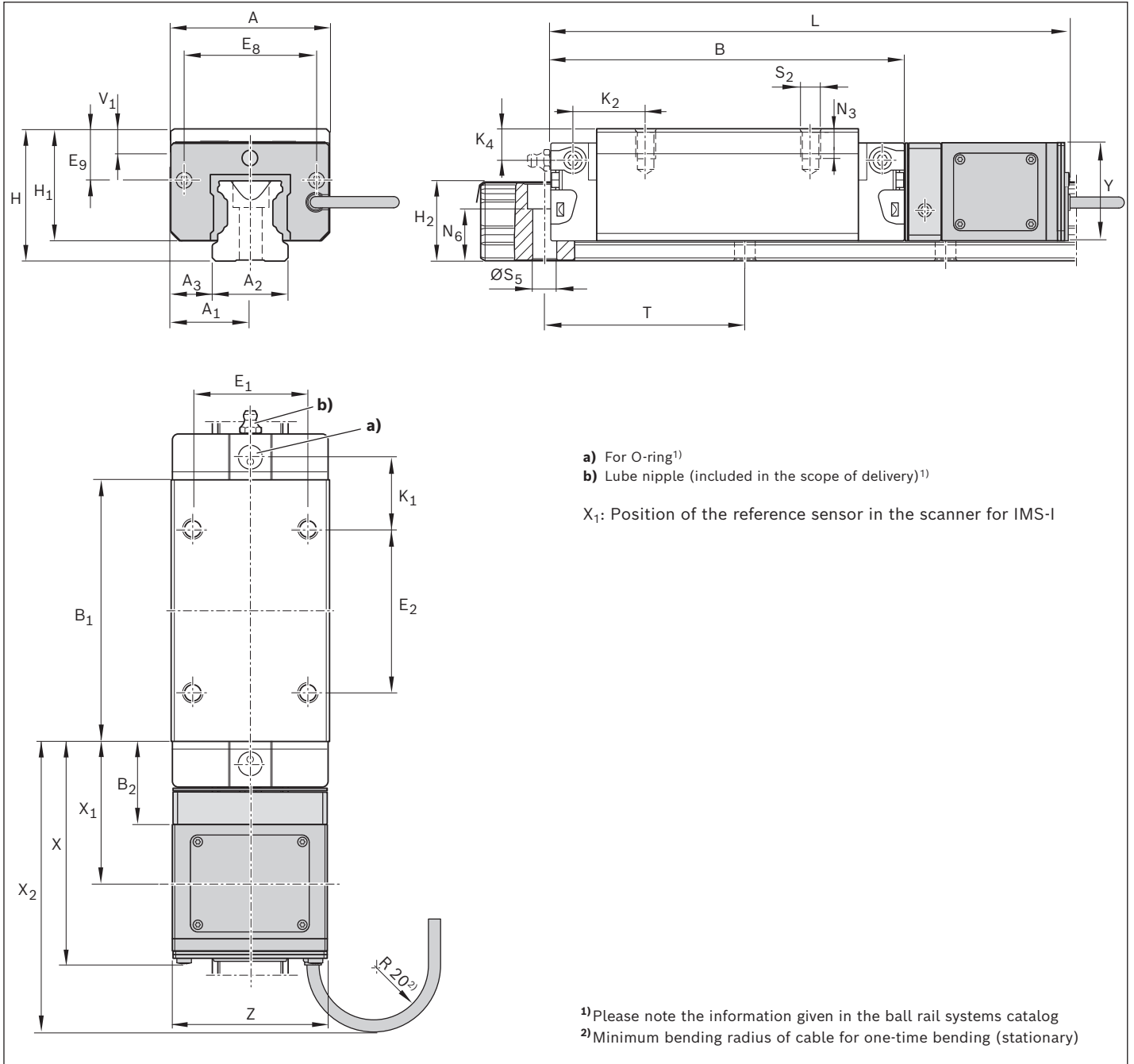

**Technical data**

Size	Weight (kg)	Max. permissible load <sup>3)</sup> (N) for preload class	Max. permissible moment load <sup>3)</sup> (Nm) for preload class		
					
	m		C1/C2	C1	C2
25	1.06		15 200	174	174
30	1.52		20 000	279	279
35	2.50		27 800	486	486
45	4.68		45 200	988	988

<sup>3)</sup>Values for ball runner block without ball chain with assembled scanner. Compliance with these values will ensure safe functioning of the application. Exceeding these values can lead to destruction of the equipment. For the life expectancy calculation, the values from the “Ball rail systems” catalog must be used. Values for ball runner block with ball chain are available on request.

# Product overview and type designation, ball guide rails

## Ball guide rails with cover strip and protective end caps and integrated scale

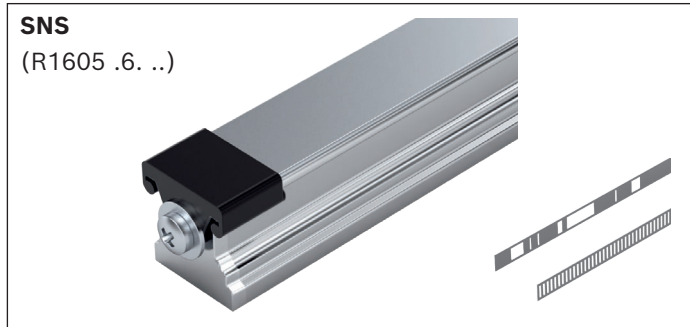

## Ball guide rails with plastic<sup>1)</sup> mounting hole plugs and integrated scale

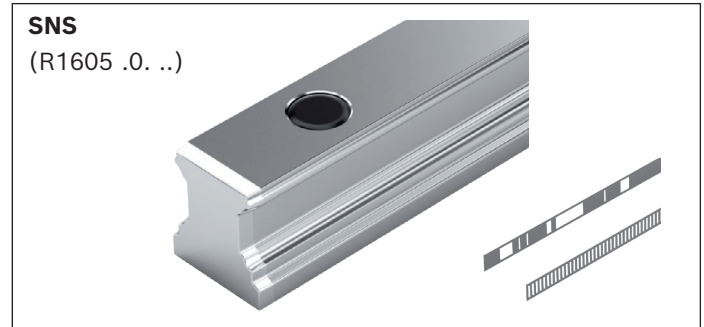

<sup>1)</sup>only for applications without dirt contamination

### Available versions

Ball guide rails SNS	Size									
	20		25		30		35		45	
	P	S	P	S	P	S	P	S	P	S
	✓	✓	✓	✓	✓	✓	✓	✓	✓	✓

✓ = Available versions

### Type designation ball guide rails with scale (example)

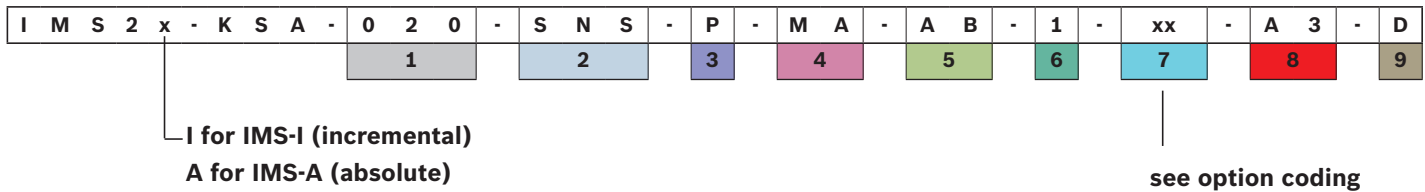

1 Size	Feature	Designation
	020	Size 20
	025	Size 25
	030	Size 30
	035	Size 35
	045	Size 45

2 Format	Feature	Designation
	SNS	Slimline, normal, standard height
	SNO	SNS without groove (on request)

3 Accuracy class	Feature	Designation
	P	Precision
	S	Super precision (SP)

4 Fastening	Feature	Designation
	MA	Mounting from above

**5 Cover**

Feature	Designation
AB	With cover strip and protective end caps
AK	With plastic mounting hole plugs

**7 Coding**

Feature	Designation
<b>IMS-I</b>	
R0	Without referencing
R1	With 1 reference mark
R2	With 2 reference marks
R3	With 3 reference marks
R4	With 4 reference marks
R5	With 5 reference marks
<b>IMS-A</b>	
AC	With absolute code band

**6 Number of sections**

Feature	Designation
1	Number of sections

**8 Accuracy class scale**

Feature	Designation
A3	3 $\mu\text{m}$
A5	5 $\mu\text{m}$

**9 Documentation**

Feature	Designation
D	Standard documentation

**IMS-I**
**Permitted positions of single reference marks (7 Coding, feature: R1 ... R5)**

Due to mechanical limit conditions, the reference mark positions should be chosen as specified in the drawing below. No reference marks may be positioned in the areas X and Y. That is, possible positions are for R1 ... R5 in such a way that these are  $>X$  and  $>Y$ . Specify the positions in increments of 1 mm.

Example: Size 20:  $R_1 = 155 \text{ mm}$ ,  $R_n = \text{rail length} - 63 \text{ mm}$ , with cover strip and protective end caps (AB).

Between the single reference marks there must be a minimum space of 10 mm.

Size	Dimensions (mm)			
	Feature AB (R1605 .6. ..)		Feature AK (R1605 .0. ..)	
	X	Y	X	Y
20	154	62	134	42
25	170	62	150	42
30	184	62	164	42
35	203	62	183	42
45	238	62	218	42

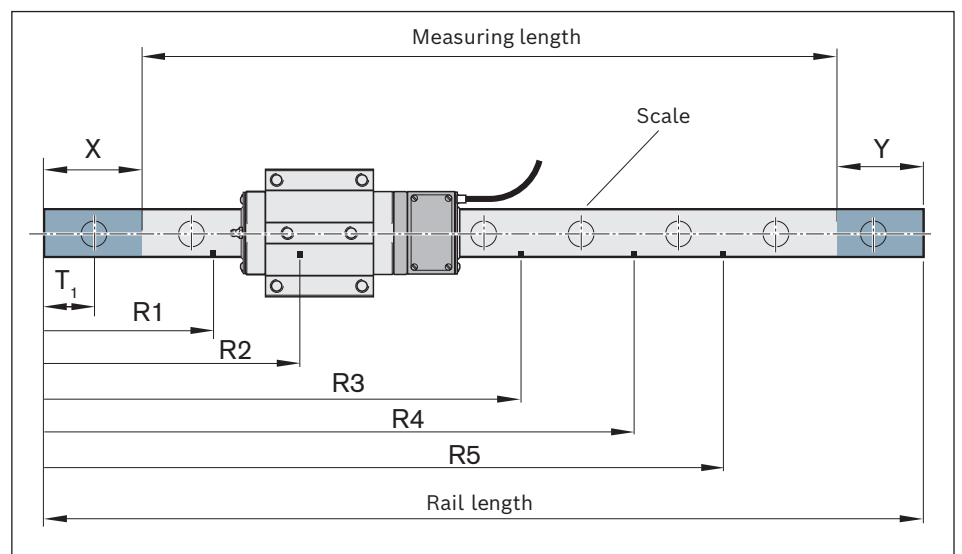

R1 ... R5 Positions of the reference marks

# Ball guide rails SNS with cover strips and protective caps

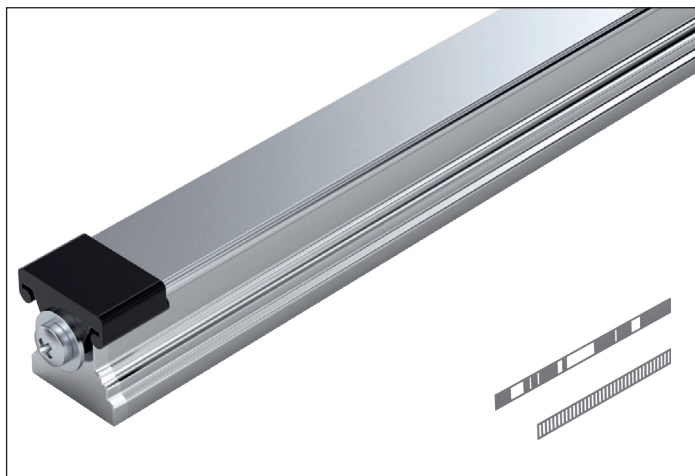

- ▶ For mounting from above, with cover strip made of corrosion-resistant spring steel per EN 10088 and screw-down plastic protective end caps (with threaded mounting holes on end faces)
- ▶ With integrated scale

### Notes

- ▶ Secure the cover strip!
- ▶ As an alternative, the cover strip can be secured with screws and washers.
- ▶ Protective caps with screws and washers are included in the scope of delivery.
- ▶ Note mounting instructions. See the chapter entitled "Mounting instructions".
- ▶ For ordering examples, see the "Ordering examples" section.

### Available versions

SNS	Size									
	20		25		30		35		45	
	P	S	P	S	P	S	P	S	P	S
	✓	✓	✓	✓	✓	✓	✓	✓	✓	✓

✓ = Available versions

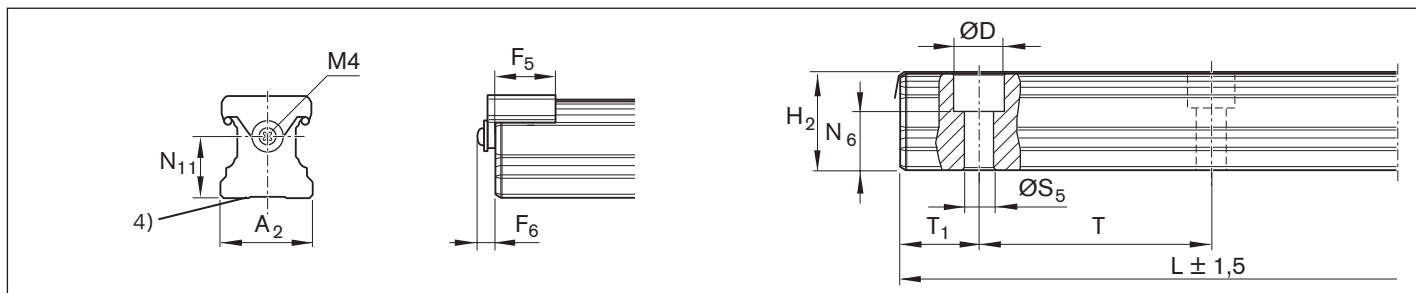

### Dimensions (mm)

Size	A <sub>2</sub>	D	F <sub>5</sub>	F <sub>6</sub>	H <sub>2</sub> <sup>1)</sup>	H <sub>2</sub> <sup>5)</sup>	L <sub>min</sub>	L <sub>max</sub>	N <sub>6</sub> <sup>±0.5</sup>	N <sub>11</sub>	ØS <sub>5</sub>	T	T <sub>1 min</sub> <sup>2)</sup>	T <sub>15</sub> <sup>3)</sup>	T <sub>1 max</sub>	Mass m (kg/m)
20	20	9.4	14.0	6.5	20.75	20.55	260	4 500	13.2	13	6	60	13	28.0	50	2.4
25	23	11.0	15.2	6.5	24.45	24.25	280	4 500	15.2	15	7	60	13	28.0	50	3.2
30	28	15.0	15.2	7.0	28.55	28.35	290	4 500	17.0	18	9	80	16	38.0	68	5.0
35	34	15.0	18.0	7.0	32.15	31.85	310	4 500	20.5	22	9	80	16	38.0	68	6.8
45	45	20.0	20.0	7.0	40.15	39.85	350	4 500	23.5	30	14	105	18	50.5	89	10.5

<sup>1)</sup> Dimension H<sub>2</sub> with cover strip

Size 20 - 30 with 0.2 mm cover strip

Size 35 - 45 with 0.3 mm cover strip

<sup>2)</sup> For end spaces below T<sub>1min</sub>, no threaded holes in end faces possible. Secure the cover strip.

<sup>3)</sup> Recommended: preferred dimension T<sub>15</sub> with tolerances ± 0.75.

<sup>4)</sup> For manufacturing reasons, rails may have a flat underside (without groove).

<sup>5)</sup> Dimension H<sub>2</sub> without cover strip



## Ball guide rails SNS with plastic mounting hole plugs

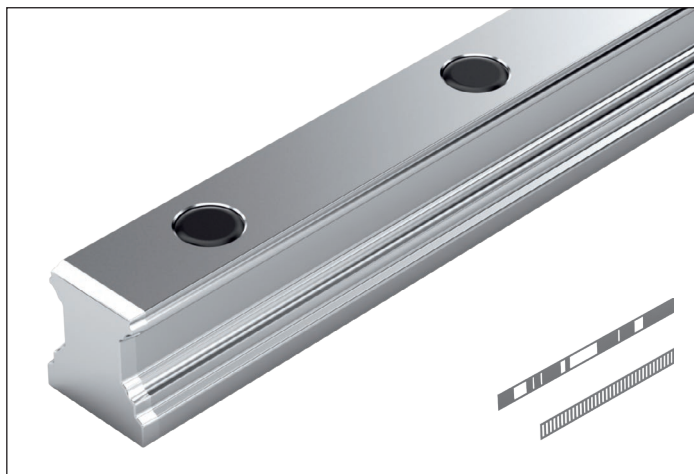

- ▶ For mounting from above with plastic mounting hole plugs
- ▶ With integrated scale

### Notes:

- ▶ Plastic mounting hole plugs included in scope of supply.
- ▶ Note mounting instructions. See the chapter entitled “Mounting instructions”.
- ▶ For ordering examples, see the “Ordering examples” section.

### Available versions

SNS	Size										
	20		25		30		35		45		
	P	S	P	S	P	S	P	S	P	S	
	✓	✓	✓	✓	✓	✓	✓	✓	✓	✓	✓

✓ = Available versions

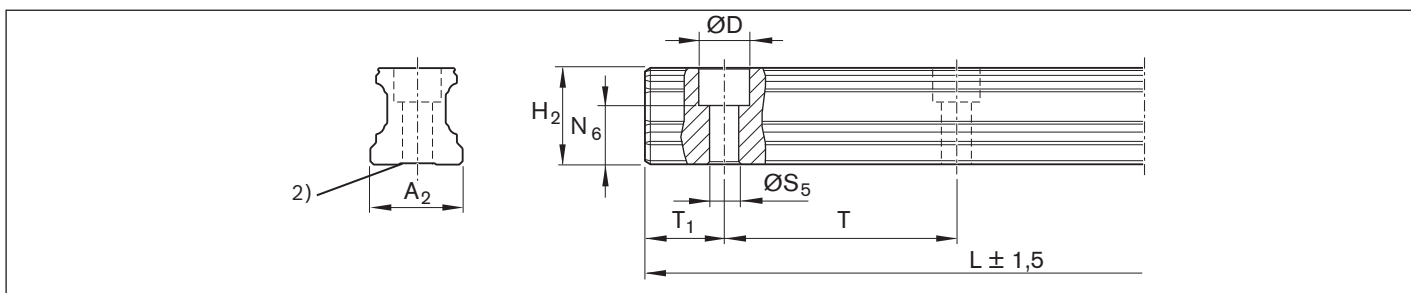

### Dimensions (mm)

Size	A <sub>2</sub>	D	H <sub>2</sub>	L <sub>min</sub>	L <sub>max</sub>	N <sub>6</sub> <sup>±0.5</sup>	S <sub>5</sub>	T	T <sub>1 min</sub>	T <sub>1S</sub> <sup>1)</sup>	T <sub>1 max</sub>	Mass m (kg/m)
20	20	9.4	20.55	220	4 500	13.2	6.0	60	10	28.0	50	2.4
25	23	11.0	24.25	240	4 500	15.2	7.0	60	10	28.0	50	3.2
30	28	15.0	28.35	250	4 500	17.0	9.0	80	12	38.0	68	5.0
35	34	15.0	31.85	270	4 500	20.5	9.0	80	12	38.0	68	6.8
45	45	20.0	39.85	310	4 500	23.5	14.0	105	16	50.5	89	10.5

<sup>1)</sup>Recommended: preferred dimension T<sub>1S</sub> with tolerances ± 0.75.

<sup>2)</sup>For manufacturing reasons, rails may have a flat underside (without groove).

## Product overview and type key roller runner blocks

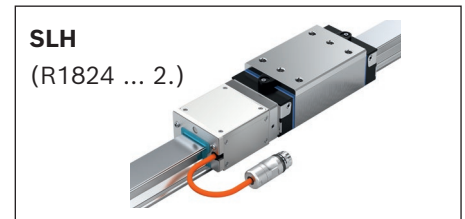
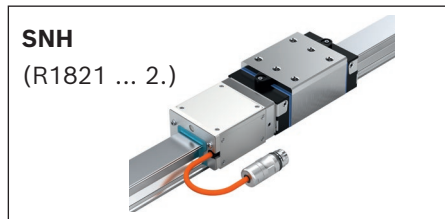
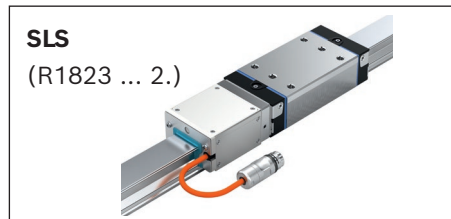
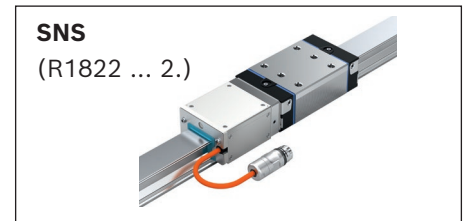
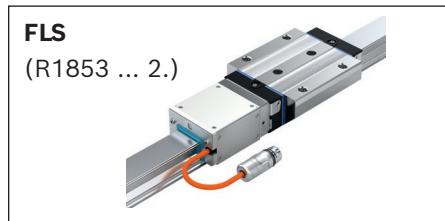
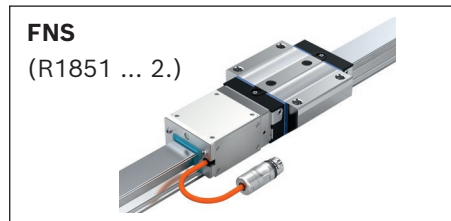

### Available versions

Roller runner block	Size															
	35				45				55				65			
	P		S		P		S		P		S		P		S	
	C2	C3	C2	C3	C2	C3	C2	C3	C2	C3	C2	C3	C2	C3	C2	C3
<b>FNS</b>	✓	✓	✓	✓	✓	✓	✓	✓	✓	✓	✓	✓	✓	✓	✓	✓
<b>FLS</b>	✓	✓	✓	✓	✓	✓	✓	✓	✓	✓	✓	✓	✓	✓	✓	✓
<b>SNS</b>	✓	✓	✓	✓	✓	✓	✓	✓	✓	✓	✓	✓	✓	✓	✓	✓
<b>SLS</b>	✓	✓	✓	✓	✓	✓	✓	✓	✓	✓	✓	✓	✓	✓	✓	✓
<b>SNH</b>	✓	✓	✓	✓	✓	✓	✓	✓	✓	✓	✓	✓				
<b>SLH</b>	✓	✓	✓	✓	✓	✓	✓	✓	✓	✓	✓	✓				

✓ = Available versions

**Type designation roller runner block with IMS-I (example)**

I	M	S	2	A	-	R	W	D	-	0	3	5	-	F	N	S	-	C	2	-	S	-	D	S	-	0	-	R	-	xx	-	A	-	1	0	0	-	D	
										1				2				3				4			5		6		7		8		9				10		11

see option interface

**1 Size**

Feature	Designation
035	Size 35
045	Size 45
055	Size 55
065	Size 65

**3 Preload class**

Feature	Designation
C2	Preload class C2
C3	Preload class C3

**5 Seal**

Feature	Designation
DS	Double-lipped

**7 Scanner mounting side**

Feature	Designation
R	Right-hand
L	Left-hand

**9 Connector type**

Feature	Designation
A	RGS 1722
B	RGS 1714
C	M12 / 8pin (only DRIVE-CLiQ)
D	M23 / 17pin (FANUC only)

**10 Cable length**

Feature	Designation
100	1.0 meter

**2 Format**

Feature	Designation
FNS	Flanged, normal, standard height
FLS	Flanged, long, standard height
SNS	Slimline, normal, standard height
SLS	Slimline, long, standard height
SNH	Slimline, normal, high
SLH	Slimline, long, high

**4 Accuracy class**

Feature	Designation
P	Precision
S	Super precision (SP)

**6 Roller chain**

Feature	Designation
0	Without roller chain

**8 Interface**

IMS-A	
Feature	Designation
HF	HIPERFACE®
DQ	DRIVE-CLiQ
FN	FANUC <i>ai</i>
S1	SSI 10 µm
S2	SSI 1 µm
S3	SSI 0.25 µm
S4	SSI 0.125 µm

**11 Documentation**

Feature	Designation
D	Standard documentation

# Roller runner blocks FNS

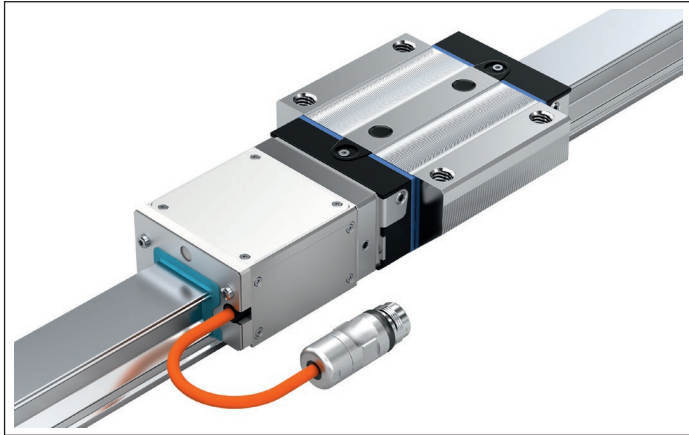

## Dynamic characteristics

See the section “Description and technical data of overall system”.

## Notes:

- ▶ Preserved (sufficient for mounting and start-up). For more details on lubrication, please refer to the “Maintenance instructions” section.
- ▶ Delivery: Roller runner block with ready-mounted adapter plate and ready-mounted scanner. A lube nipple is included in the delivery.
- ▶ Note mounting instructions. See the chapter entitled “Mounting instructions”.
- ▶ For ordering examples, see the “Ordering examples” section.

## Available versions

FNS	Size															
	35				45				55				65			
	P		S		P		S		P		S		P		S	
	C2	C3	C2	C3	C2	C3	C2	C3	C2	C3	C2	C3	C2	C3	C2	C3
✓	✓	✓	✓	✓	✓	✓	✓	✓	✓	✓	✓	✓	✓	✓	✓	✓

✓ = Available versions

## Dimensions (mm)



Size	A	A <sub>1</sub>	A <sub>2</sub>	A <sub>3</sub>	B	B <sub>1</sub>	B <sub>2</sub>	E <sub>1</sub>	E <sub>2</sub>	E <sub>3</sub>	E <sub>8</sub>	E <sub>9</sub>	H	H <sub>1</sub>	H <sub>2</sub> <sup>1</sup>	H <sub>2</sub> <sup>2</sup>	K <sub>1</sub>
35	100	50	34	33.0	118.00	79.6	31.45	82	62	52	50.30	13.10	48	41	31.10	30.80	15.55
45	120	60	45	37.5	147.00	101.5	35.00	100	80	60	62.90	16.70	60	51	39.10	38.80	17.45
55	140	70	53	43.5	170.65	123.1	38.03	116	95	70	74.20	18.85	70	58	47.85	47.55	21.75
65	170	85	63	53.5	207.30	146.0	46.65	142	110	82	35.00	9.30	90	76	58.15	57.85	30.00

Size	K <sub>2</sub>	L	N <sub>1</sub>	N <sub>5</sub>	N <sub>6</sub> <sup>±0.5</sup>	∅S <sub>1</sub>	S <sub>2</sub>	∅S <sub>5</sub>	T <sub>2</sub>	V <sub>1</sub>	X	X <sub>1</sub>	X <sub>2</sub>	Y	Z
35	17.40	198.9	12	7.0	19.8	8.5	M10	9	40.0	8	99.60	61.45	124.60	40.00	63.8
45	20.35	229.6	15	8.0	22.8	10.4	M12	14	52.5	10	104.85	65.00	129.85	50.00	78.0
55	24.90	256.4	18	9.0	28.7	12.4	M14	16	60.0	12	109.03	68.03	134.03	56.35	91.4
65	33.00	293.3	23	9.3	36.5	14.6	M16	18	75.0	15	116.75	76.65	141.75	75.00	119.0

<sup>1</sup>)Dimension H<sub>2</sub> with cover strip

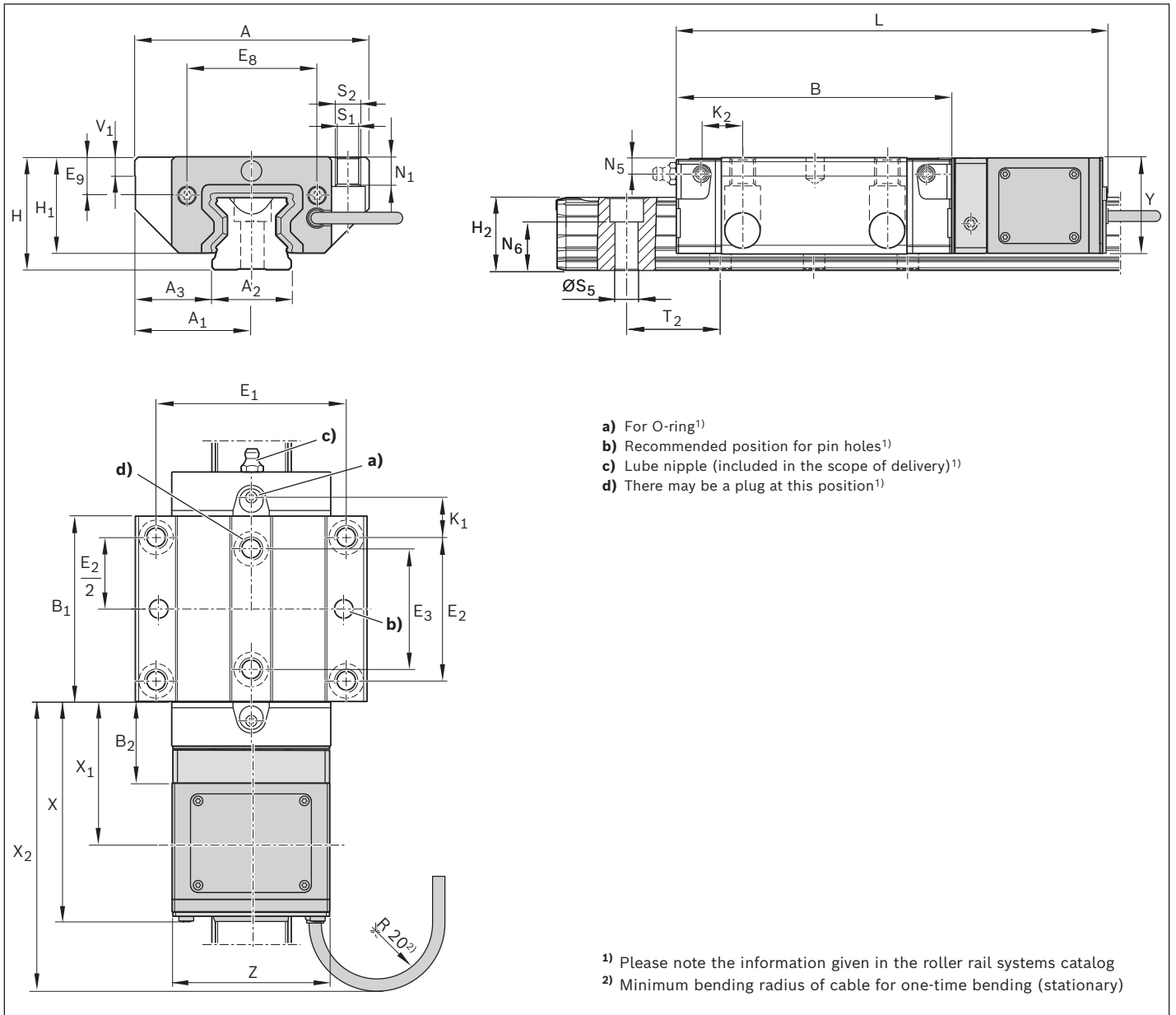
<sup>2</sup>)Dimension H<sub>2</sub> without cover strip

**Technical data**

Size	Weight (kg)	Max. permissible load <sup>3)</sup> (N) for preload class	Max. permissible moment load <sup>3)</sup> (Nm) for preload class	
			 C2/C3	 M <sub>Z</sub> max C2/C3
35	2.52		30 500	380
45	4.57		53 300	825
55	6.13		70 200	1 305
65	11.96		118 600	2 630

<sup>3)</sup> Values for roller runner block with assembled scanner. Compliance with these values will ensure safe functioning of the application. Exceeding these values can lead to destruction of the equipment. For the nominal life calculation, the values from the "Roller rail systems" catalog must be used.

# Roller runner blocks FLS

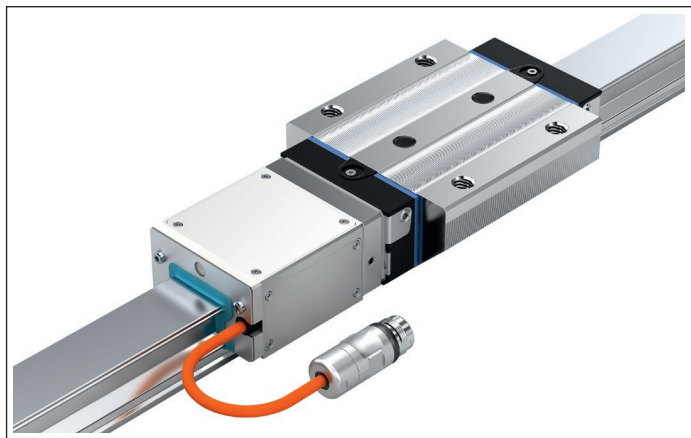

## Dynamic characteristics

See the section “Description and technical data of overall system”.

## Notes:

- ▶ Preserved (sufficient for mounting and start-up). For more details on lubrication, please refer to the “Maintenance instructions” section.
- ▶ Delivery: Roller runner block with ready-mounted adapter plate and ready-mounted scanner. A lube nipple is included in the delivery.
- ▶ Note mounting instructions. See the chapter entitled “Mounting instructions”.
- ▶ For ordering examples, see the “Ordering examples” section.

## Available versions

FLS	Size															
	35				45				55				65			
	P		S		P		S		P		S		P		S	
	C2	C3	C2	C3	C2	C3	C2	C3	C2	C3	C2	C3	C2	C3	C2	C3
	✓	✓	✓	✓	✓	✓	✓	✓	✓	✓	✓	✓	✓	✓	✓	✓

✓ = Available versions

## Dimensions (mm)



Size	A	A <sub>1</sub>	A <sub>2</sub>	A <sub>3</sub>	B	B <sub>1</sub>	B <sub>2</sub>	E <sub>1</sub>	E <sub>2</sub>	E <sub>3</sub>	E <sub>4</sub>	E <sub>8</sub>	E <sub>9</sub>	H	H <sub>1</sub>	H <sub>2</sub> <sup>1</sup>	H <sub>2</sub> <sup>2</sup>	K <sub>1</sub>
35	100	50	34	33.0	142.00	103.6	31.45	82	62	52	80	50.3	13.10	48	41	31.10	30.80	27.55
45	120	60	45	37.5	179.50	134.0	35.00	100	80	60	98	62.9	16.70	60	51	39.10	38.80	33.70
55	140	70	53	43.5	209.65	162.1	38.03	116	95	70	114	74.2	18.85	70	58	47.85	47.55	41.25
65	170	85	63	53.5	255.30	194.0	46.65	142	110	82	140	35.0	9.30	90	76	58.15	57.85	54.00

Size	K <sub>2</sub>	L	N <sub>1</sub>	N <sub>5</sub>	N <sub>6</sub> <sup>±0.5</sup>	∅S <sub>1</sub>	S <sub>2</sub>	∅S <sub>5</sub>	T <sub>2</sub>	V <sub>1</sub>	X	X <sub>1</sub>	X <sub>2</sub>	Y	Z
35	29.4	222.6	12	7.0	19.8	8.5	M10	9	40.0	8	99.60	61.45	124.60	40.00	63.8
45	36.6	262.1	15	8.0	22.8	10.4	M12	14	52.5	10	104.85	65.00	129.85	50.00	78.0
55	44.4	295.4	18	9.0	28.7	12.4	M14	16	60.0	12	109.03	68.03	134.03	56.35	91.4
65	57.0	341.3	23	9.3	36.5	14.6	M16	18	75.0	15	116.75	76.65	141.75	75.00	119.0

<sup>1</sup>)Dimension H<sub>2</sub> with cover strip

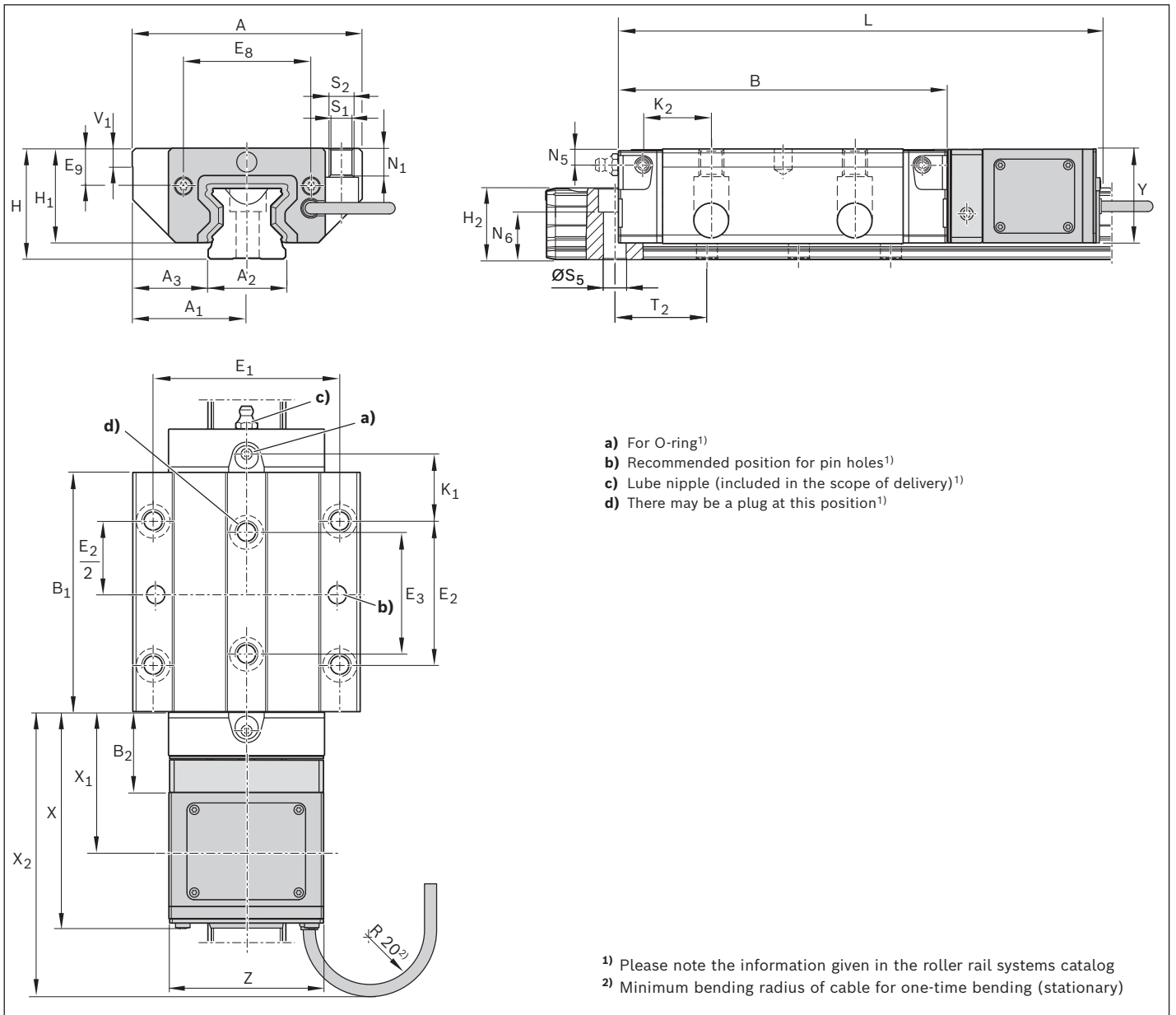
<sup>2</sup>)Dimension H<sub>2</sub> without cover strip

**Technical data**

Size	Weight (kg)	Max. permissible load <sup>3)</sup> (N) for preload class	Max. permissible moment load <sup>3)</sup> (Nm) for preload class	
				
	m		C2/C3	C2/C3
35	3.07		37 450	610
45	5.67		66 150	1 345
55	7.84		87 000	2 210
65	15.42		147 950	4 435

<sup>3)</sup> Values for roller runner block with assembled scanner. Compliance with these values will ensure safe functioning of the application. Exceeding these values can lead to destruction of the equipment. For the nominal life calculation, the values from the "Roller rail systems" catalog must be used.

## Roller runner blocks SNS

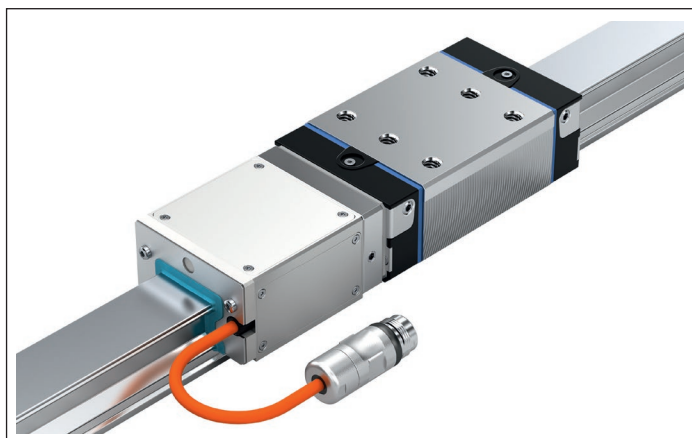

### Dynamic characteristics

See the section “Description and technical data of overall system”.

### Notes:

- ▶ Preserved (sufficient for mounting and start-up). For more details on lubrication, please refer to the “Maintenance instructions” section.
- ▶ Delivery: Roller runner block with ready-mounted adapter plate and ready-mounted scanner. A lube nipple is included in the delivery.
- ▶ Note mounting instructions. See the chapter entitled “Mounting instructions”.
- ▶ For ordering examples, see the “Ordering examples” section.

### Available versions

SNS	Size															
	35				45				55				65			
	P		S		P		S		P		S		P		S	
	C2	C3	C2	C3	C2	C3	C2	C3	C2	C3	C2	C3	C2	C3	C2	C3
	✓	✓	✓	✓	✓	✓	✓	✓	✓	✓	✓	✓	✓	✓	✓	✓

✓ = Available versions

### Dimensions (mm)

Size	A	A <sub>1</sub>	A <sub>2</sub>	A <sub>3</sub>	B	B <sub>1</sub>	B <sub>2</sub>	E <sub>1</sub>	E <sub>2</sub>	E <sub>8</sub>	E <sub>9</sub>	H	H <sub>1</sub>	H <sub>2</sub> <sup>1</sup>	H <sub>2</sub> <sup>2</sup>	K <sub>1</sub>
35	70	35	34	18.0	118.00	79.6	31.45	50	50	50.3	13.10	48	41	31.10	30.80	21.55
45	86	43	45	20.5	147.00	101.5	35.00	60	60	62.9	16.70	60	51	39.10	38.80	27.45
55	100	50	53	23.5	170.65	123.1	38.03	75	75	74.2	18.85	70	58	47.85	47.55	31.75
65	126	63	63	31.5	207.30	146.0	46.65	76	70	35.0	9.30	90	76	58.15	57.85	50.00

Size	K <sub>2</sub>	L	N <sub>3</sub>	N <sub>5</sub>	N <sub>6</sub> <sup>±0.5</sup>	S <sub>2</sub>	∅S <sub>5</sub>	T <sub>2</sub>	V <sub>1</sub>	X	X <sub>1</sub>	X <sub>2</sub>	Y	Z
35	23.40	198.9	12	7.0	19.8	M8	9	40.0	8	99.60	61.45	124.60	40.00	63.8
45	30.35	229.6	18	8.0	22.8	M10	14	52.5	10	104.85	65.00	129.85	50.00	78.0
55	34.90	256.4	17	9.0	28.7	M12	16	60.0	12	109.03	68.03	134.03	56.35	91.4
65	53.00	293.3	21	9.3	36.5	M16	18	75.0	15	116.75	76.65	141.75	75.00	119.0

<sup>1</sup>)Dimension H<sub>2</sub> with cover strip

<sup>2</sup>)Dimension H<sub>2</sub> without cover strip



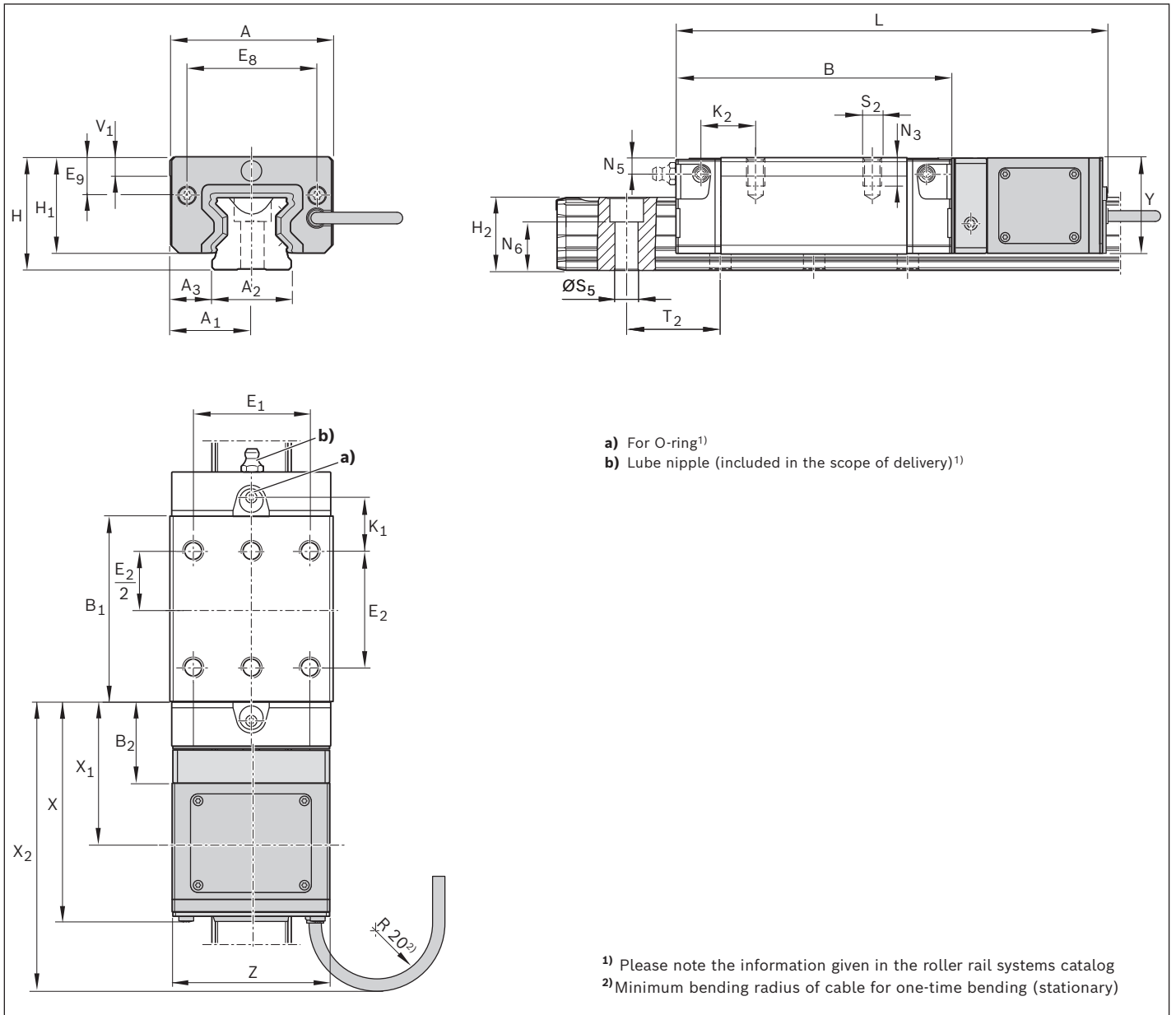

### Technical data

Size	Weight (kg)	Max. permissible load <sup>3)</sup> (N) for preload class	Max. permissible moment load <sup>3)</sup> (Nm) for preload class	
			$M_Z$ max	
	<b>m</b>		<b>C2/C3</b>	
<b>35</b>	1.92		30 500	380
<b>45</b>	3.42		53 300	825
<b>55</b>	4.83		70 200	1 305
<b>65</b>	9.36		118 600	2 630

<sup>3)</sup> Values for roller runner block with assembled scanner. Compliance with these values will ensure safe functioning of the application. Exceeding these values can lead to destruction of the equipment. For the nominal life calculation, the values from the "Roller rail systems" catalog must be used.

# Roller runner blocks SLS

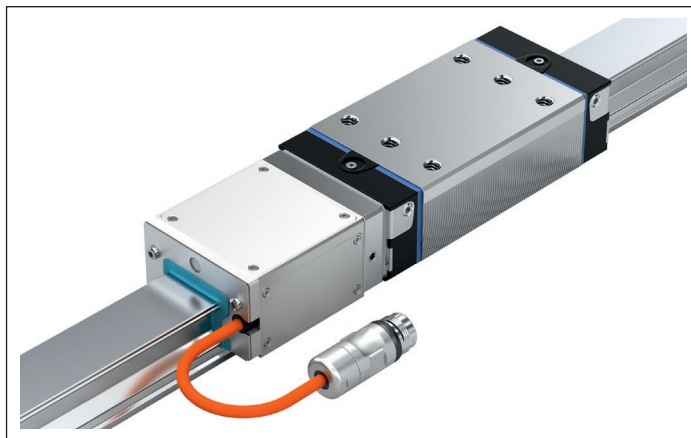

## Dynamic characteristics

See the section “Description and technical data of overall system”.

## Notes:

- ▶ Preserved (sufficient for mounting and start-up). For more details on lubrication, please refer to the “Maintenance instructions” section.
- ▶ Delivery: Roller runner block with ready-mounted adapter plate and ready-mounted scanner. A lube nipple is included in the delivery.
- ▶ Note mounting instructions. See the chapter entitled “Mounting instructions”.
- ▶ For ordering examples, see the “Ordering examples” section.

## Available versions

SLS	Size															
	35				45				55				65			
	P		S		P		S		P		S		P		S	
	C2	C3	C2	C3	C2	C3	C2	C3	C2	C3	C2	C3	C2	C3	C2	C3
	✓	✓	✓	✓	✓	✓	✓	✓	✓	✓	✓	✓	✓	✓	✓	✓

✓ = Available versions

## Dimensions (mm)



Size	A	A <sub>1</sub>	A <sub>2</sub>	A <sub>3</sub>	B	B <sub>1</sub>	B <sub>2</sub>	E <sub>1</sub>	E <sub>2</sub>	E <sub>8</sub>	E <sub>9</sub>	H	H <sub>1</sub>	H <sub>2</sub> <sup>1</sup>	H <sub>2</sub> <sup>2</sup>	K <sub>1</sub>
35	70	35	34	18.0	142.00	103.6	31.45	50	72	50.3	13.10	48	41	31.10	30.80	22.55
45	86	43	45	20.5	179.50	134.0	35.00	60	80	62.9	16.70	60	51	39.10	38.80	33.70
55	100	50	53	23.5	209.65	162.1	38.03	75	95	74.2	18.85	70	58	47.85	47.55	41.25
65	126	63	63	31.5	255.30	194.0	46.65	76	120	35.0	9.30	90	76	58.15	57.85	49.00

Size	K <sub>2</sub>	L	N <sub>3</sub>	N <sub>5</sub>	N <sub>6</sub> <sup>±0.5</sup>	S <sub>2</sub>	ØS <sub>5</sub>	T <sub>2</sub>	V <sub>1</sub>	X	X <sub>1</sub>	X <sub>2</sub>	Y	Z
35	24.4	222.6	12	7.0	19.8	M8	9	40.0	8	99.60	61.45	124.60	40.00	63.8
45	36.6	262.1	18	8.0	22.8	M10	14	52.5	10	104.85	65.00	129.85	50.00	78.0
55	44.4	295.4	17	9.0	28.7	M12	16	60.0	12	109.03	68.03	134.03	56.35	91.4
65	52.0	341.3	21	9.3	36.5	M16	18	75.0	15	116.75	76.65	141.75	75.00	119.0

<sup>1</sup>)Dimension H<sub>2</sub> with cover strip

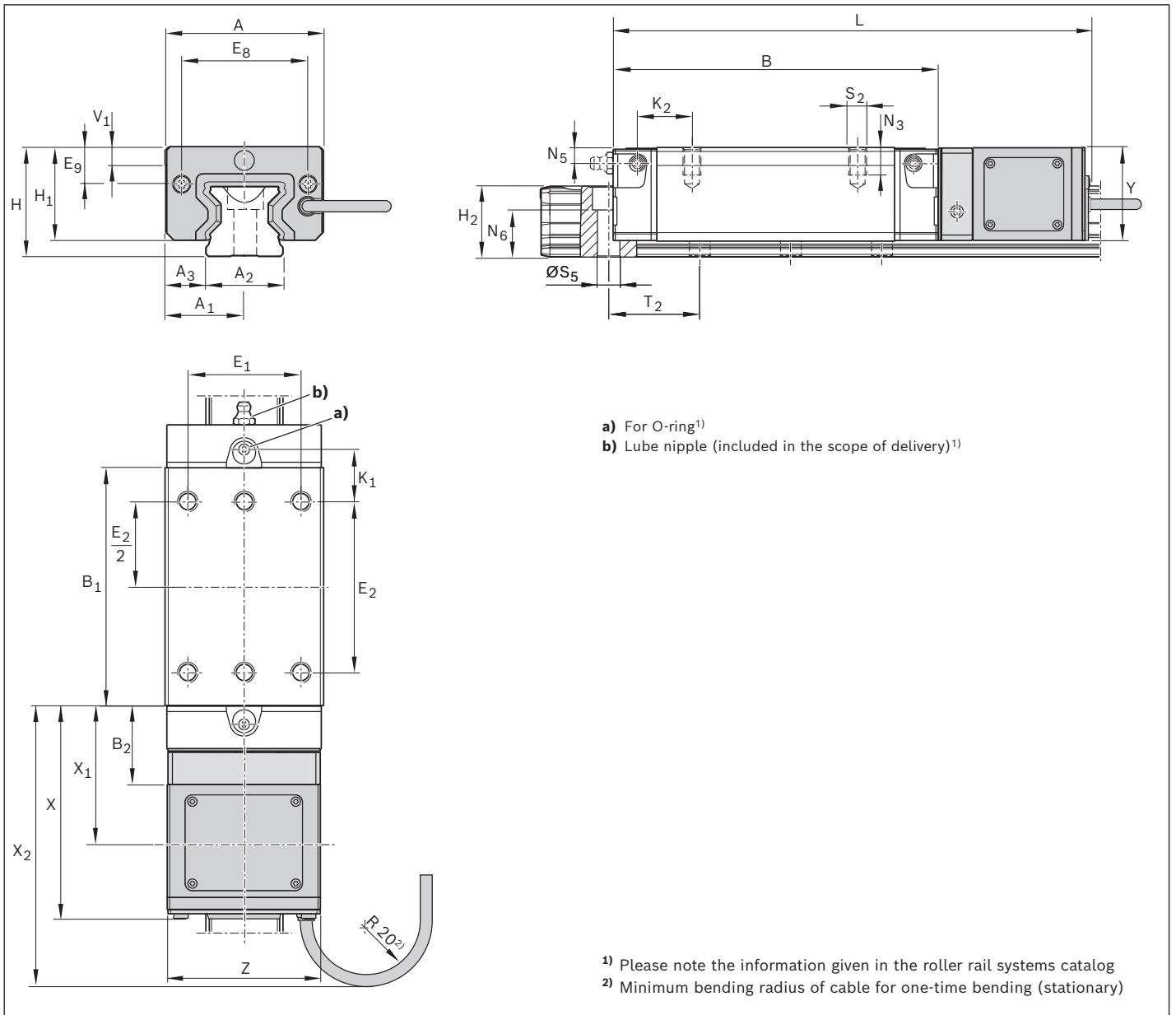
<sup>2</sup>)Dimension H<sub>2</sub> without cover strip

**Technical data**

Size	Weight (kg)	Max. permissible load <sup>3)</sup> (N) for preload class	Max. permissible moment load <sup>3)</sup> (Nm) for preload class	
				
	m		C2/C3	C2/C3
35	2.32		37 450	610
45	4.17		66 150	1 345
55	5.99		87 000	2 210
65	11.92		147 950	4 435

<sup>3)</sup> Values for roller runner block with assembled scanner. Compliance with these values will ensure safe functioning of the application. Exceeding these values can lead to destruction of the equipment. For the nominal life calculation, the values from the "Roller rail systems" catalog must be used.

# Roller runner blocks SNH

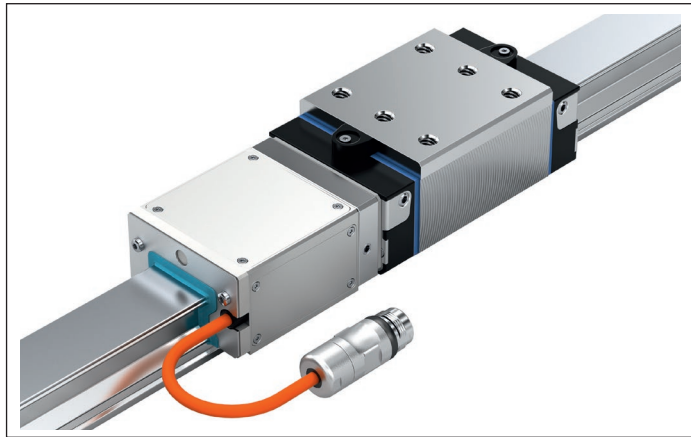

## Dynamic characteristics

See the section “Description and technical data of overall system”.

## Notes:

- ▶ Preserved (sufficient for mounting and start-up). For more details on lubrication, please refer to the “Maintenance instructions” section.
- ▶ Delivery: Roller runner block with ready-mounted adapter plate and ready-mounted scanner. A lube nipple is included in the delivery.
- ▶ Note mounting instructions. See the chapter entitled “Mounting instructions”.
- ▶ For ordering examples, see the “Ordering examples” section.

## Available versions

SNH	Size											
	35				45				55			
	P		S		P		S		P		S	
C2	C3	C2	C3	C2	C3	C2	C3	C2	C3	C2	C3	
	✓	✓	✓	✓	✓	✓	✓	✓	✓	✓	✓	✓

✓ = Available versions

## Dimensions (mm)

Size	A	A <sub>1</sub>	A <sub>2</sub>	A <sub>3</sub>	B	B <sub>1</sub>	B <sub>2</sub>	E <sub>1</sub>	E <sub>2</sub>	E <sub>8</sub>	E <sub>9</sub>	H	H <sub>1</sub>	H <sub>2</sub> <sup>1</sup>	H <sub>2</sub> <sup>2</sup>	K <sub>1</sub>
35	70	35	34	18.0	118.00	79.6	31.45	50	50	50.3	20.10	55	48	31.10	30.80	21.55
45	86	43	45	20.5	147.00	101.5	35.00	60	60	62.9	26.70	70	61	39.10	38.80	27.45
55	100	50	53	23.5	170.65	123.1	38.03	75	75	74.2	28.85	80	68	47.85	47.55	31.75



Size	K <sub>2</sub>	L	N <sub>3</sub>	N <sub>5</sub>	N <sub>6</sub> <sup>±0.5</sup>	S <sub>2</sub>	∅S <sub>5</sub>	T <sub>2</sub>	V <sub>1</sub>	X	X <sub>1</sub>	X <sub>2</sub>	Y	Z
35	23.40	198.9	13	14	19.8	M8	9	40.0	8	99.60	61.45	124.60	40.00	63.8
45	30.35	229.6	18	18	22.8	M10	14	52.5	10	104.85	65.00	129.85	50.00	78.0
55	34.90	256.4	19	19	28.7	M12	16	60.0	12	109.03	68.03	134.03	56.35	91.4

<sup>1</sup>)Dimension H<sub>2</sub> with cover strip

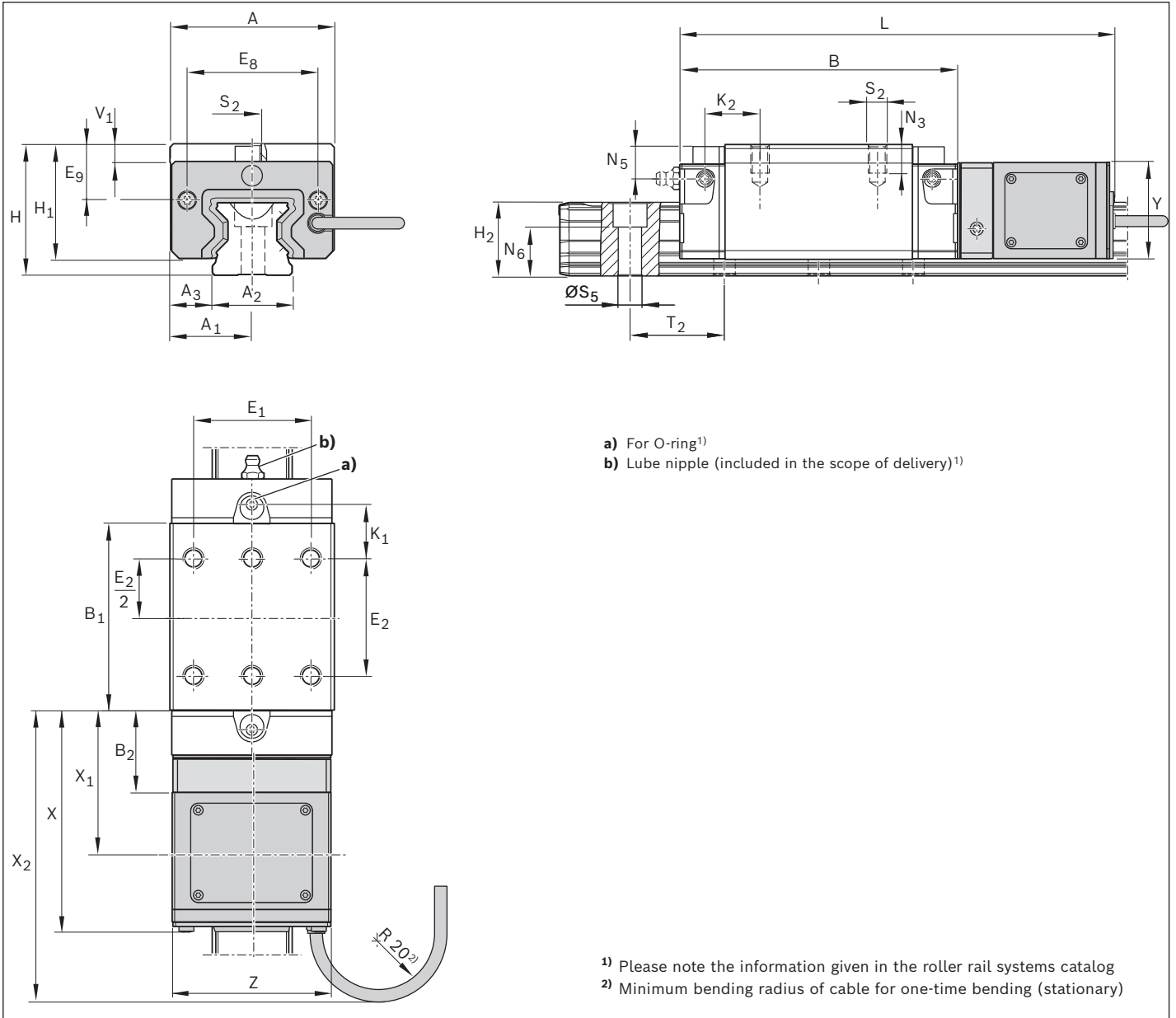
<sup>2</sup>)Dimension H<sub>2</sub> without cover strip



**Technical data**

Size	Weight (kg)	Max. permissible load <sup>3)</sup> (N) for preload class	Max. permissible moment load <sup>3)</sup> (Nm) for preload class	
				
	m		C2/C3	C2/C3
35	2.22		30 500	380
45	3.87		53 300	825
55	5.73		70 200	1 305

<sup>3)</sup> Values for roller runner block with assembled scanner. Compliance with these values will ensure safe functioning of the application. Exceeding these values can lead to destruction of the equipment. For the nominal life calculation, the values from the “Roller rail systems” catalog must be used.

# Roller runner blocks SLH

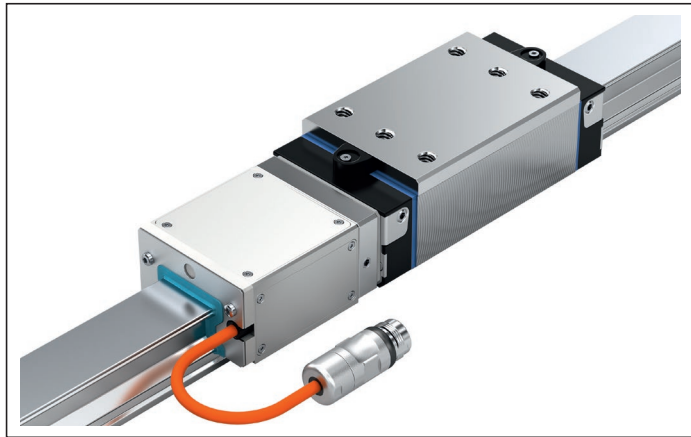

## Dynamic characteristics

See the section “Description and technical data of overall system”.

## Notes:

- ▶ Preserved (sufficient for mounting and start-up). For more details on lubrication, please refer to the “Maintenance instructions” section.
- ▶ Delivery: Roller runner block with ready-mounted adapter plate and ready-mounted scanner. A lube nipple is included in the delivery.
- ▶ Note mounting instructions. See the chapter entitled “Mounting instructions”.
- ▶ For ordering examples, see the “Ordering examples” section.

## Available versions

SLH	Size														
	35				45				55						
	P		S		P		S		P		S				
	C2	C3	C2	C3	C2	C3	C2	C3	C2	C3	C2	C3			
	✓	✓	✓	✓	✓	✓	✓	✓	✓	✓	✓	✓	✓	✓	✓

✓ = Available versions

## Dimensions (mm)

Size	A	A <sub>1</sub>	A <sub>2</sub>	A <sub>3</sub>	B	B <sub>1</sub>	B <sub>2</sub>	E <sub>1</sub>	E <sub>2</sub>	E <sub>8</sub>	E <sub>9</sub>	H	H <sub>1</sub>	H <sub>2</sub> <sup>1</sup>	H <sub>2</sub> <sup>2</sup>	K <sub>1</sub>
35	70	35	34	18.0	142.00	103.6	31.45	50	72	50.3	20.10	55	48	31.10	30.80	22.55
45	86	43	45	20.5	179.50	134.0	35.00	60	80	62.9	26.70	70	61	39.10	38.80	33.70
55	100	50	53	23.5	209.65	162.1	38.03	75	95	74.2	28.85	80	68	47.85	47.55	41.25

Size	L	K <sub>2</sub>	N <sub>3</sub>	N <sub>5</sub>	N <sub>6</sub> <sup>±0.5</sup>	S <sub>2</sub>	∅S <sub>5</sub>	T <sub>2</sub>	V <sub>1</sub>	X	X <sub>1</sub>	X <sub>2</sub>	Y	Z
35	222.6	24.4	13	14	19.8	M8	9	40.0	8	99.60	61.45	124.60	40.00	63.8
45	262.1	36.6	18	18	22.8	M10	14	52.5	10	104.85	65.00	129.85	50.00	78.0
55	295.4	44.4	19	19	28.7	M12	16	60.0	12	109.03	68.03	134.03	56.35	91.4

<sup>1</sup>) Dimension H<sub>2</sub> with cover strip

<sup>2</sup>) Dimension H<sub>2</sub> without cover strip

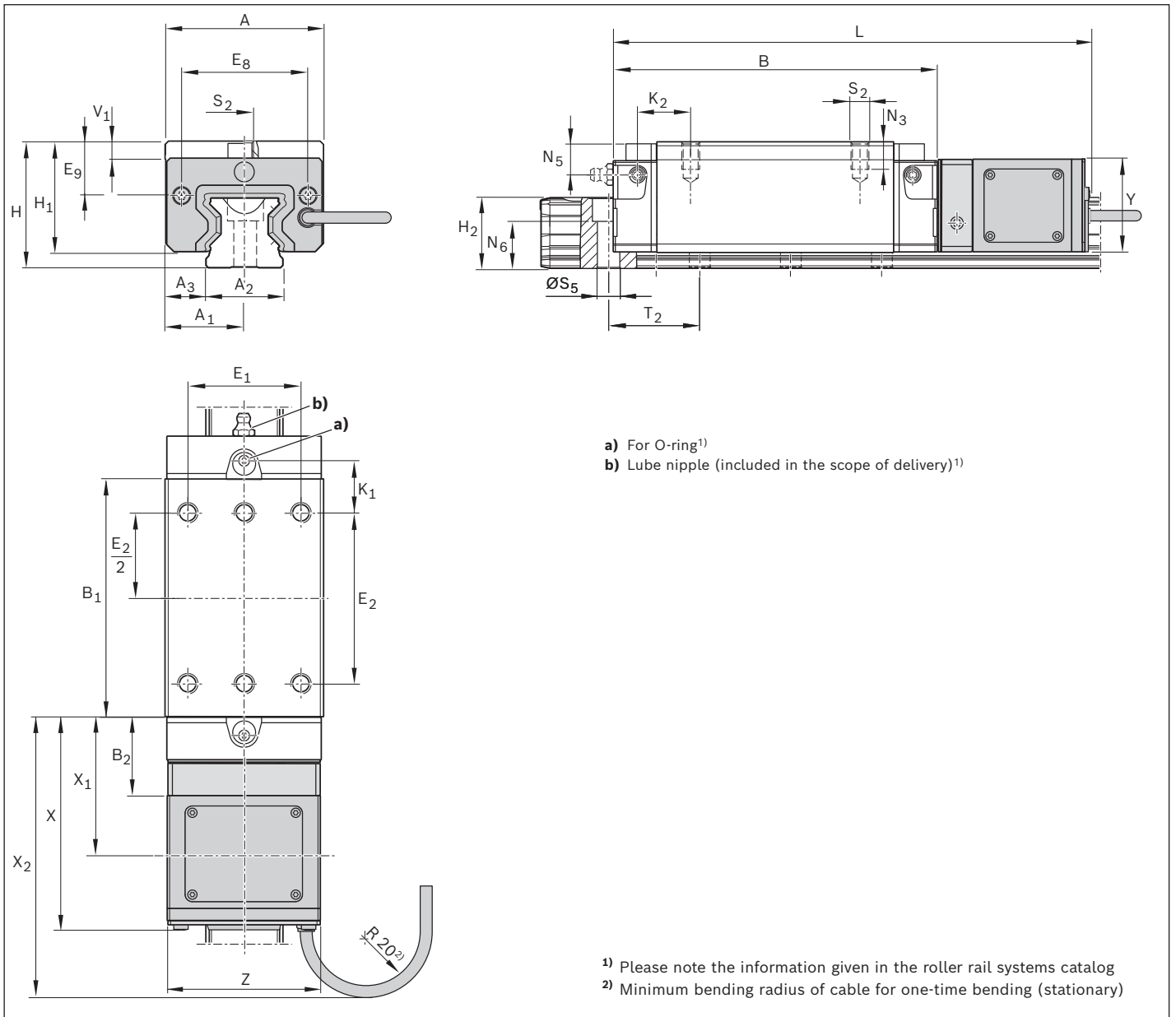

### Technical data

Size	Weight (kg)	Max. permissible load <sup>3)</sup> (N) for preload class	Max. permissible moment load <sup>3)</sup> (Nm) for preload class
	m	C2/C3	C2/C3
35	2.72	37 450	610
45	4.97	66 150	1 345
55	7.24	87 000	2 210

<sup>3)</sup> Values for roller runner block with assembled scanner. Compliance with these values will ensure safe functioning of the application. Exceeding these values can lead to destruction of the equipment. For the nominal life calculation, the values from the “Roller rail systems” catalog must be used.

# Product overview and type designation, roller guide rails

## Roller guide rails with cover strip and protective end caps and integrated scale

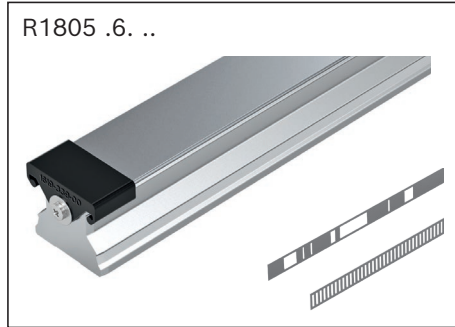

## Roller guide rails with plastic<sup>1)</sup> mounting hole plugs and integrated scale

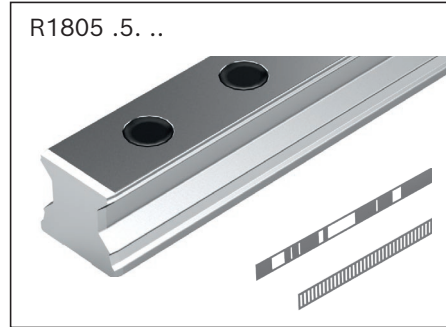

## Roller guide rails with steel mounting hole plugs and integrated scale

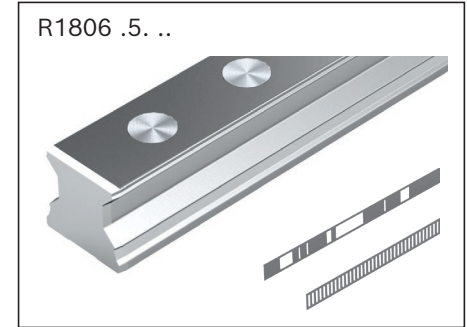

<sup>1)</sup>only for applications without dirt contamination

### Available versions

Roller guide rails SNS	Size								
	35		45		55		65		
	P	S	P	S	P	S	P	S	
	✓	✓	✓	✓	✓	✓	✓	✓	✓

✓ = Available versions

### Type designation for roller guide rails with scale (example)

I	M	S	2	A	-	R	S	A	-	0	3	5	-	S	N	S	-	S	-	M	A	-	A	B	-	1	-	AC	-	A	3	-	D
										1				2				3		4			5			6		7		8			9

1 Size	Feature	Designation
	035	Size 35
	045	Size 45
	055	Size 55
	065	Size 65 (only for IMS-A)

2 Format	Feature	Designation
	SNS	Slimline, normal, standard height
	SNO	SNS without groove (on request)

3 Accuracy class	Feature	Designation
	P	Precision
	S	Super precision (SP)

4 Fastening	Feature	Designation
	MA	Mounting from above



**5 Cover**

Feature	Designation
w	With cover strip and protective end caps
AK	With plastic mounting hole plugs
SK	With steel mounting hole plugs

**7 Coding**

Feature	Designation
<b>IMS-A</b>	
AC	With absolute code band

**6 Number of sections**

Feature	Designation
1	Number of sections

**8 Accuracy class**

Feature	Designation
A3	3 µm
A5	5 µm

**9 Documentation**

Feature	Designation
D	Standard documentation

# Roller guide rails SNS with cover strip and protective end caps

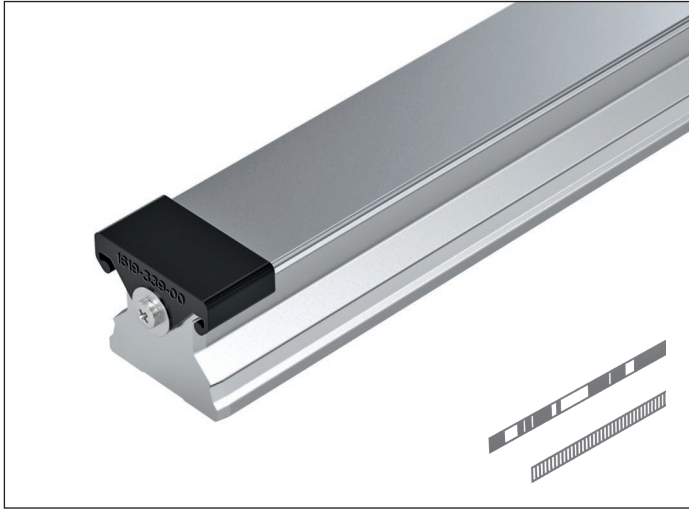

- ▶ For mounting from above, with cover strip made of corrosion-resistant spring steel per EN 10088 and screw-down plastic protective end caps (with threaded mounting holes on end faces)
- ▶ With integrated scale

### Notes

- ▶ Secure the cover strip!
- ▶ As an alternative, the cover strip can be secured with screws and washers.
- ▶ Protective caps with screws and washers are included in the scope of delivery.
- ▶ Note mounting instructions. See the chapter entitled "Mounting instructions".
- ▶ For ordering examples, see the "Ordering examples" section.

### Available versions

Roller guide rails SNS	Size								
	35		45		55		65		
	P	S	P	S	P	S	P	S	
	✓	✓	✓	✓	✓	✓	✓	✓	✓

✓ = Available versions

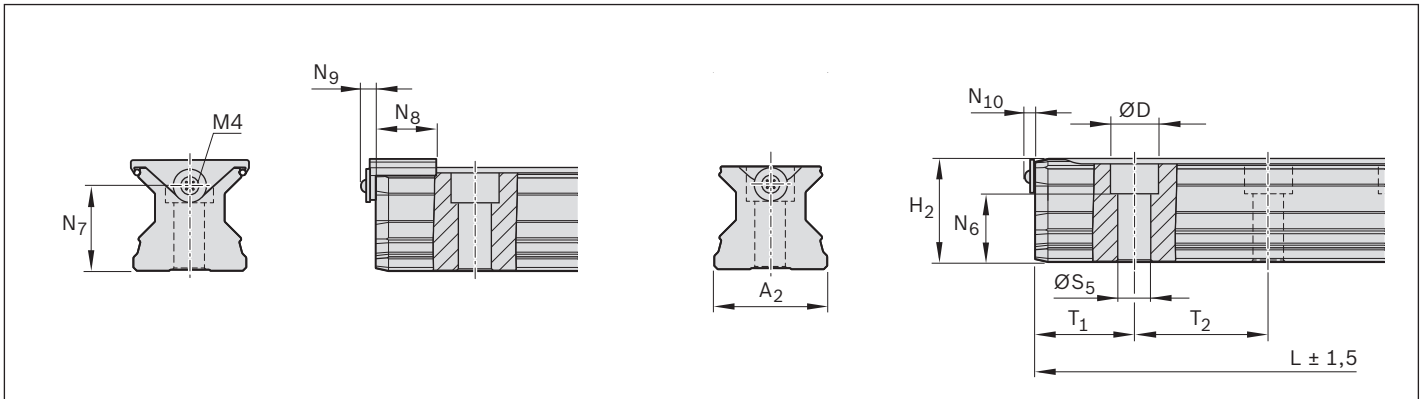

### Dimensions (mm)

Size	A <sub>2</sub>	D	H <sub>2</sub> <sup>1)</sup>	L <sub>min</sub>	L <sub>max</sub> <sup>2)</sup>	N <sub>6</sub>	N <sub>7</sub>	N <sub>8</sub>	N <sub>9</sub>	N <sub>10</sub>	ØS <sub>5</sub>	T <sub>1 min</sub>	T <sub>1 s</sub> <sup>3)</sup>	T <sub>1 max</sub>	T <sub>2</sub>	Mass m (kg/m)
35	34	15	31.10	312	3 996	19.4	22	18	7	4.10	9	16	18.00	28.0	40.0	6.3
45	45	20	39.10	351	3 986	22.4	30	20	7	4.10	14	18	24.25	36.5	52.5	10.3
55	53	24	47.85	400	3 956	28.7	30	20	7	4.35	16	20	28.00	42.0	60.0	13.1
65	63	26	58.15	430	3 971	36.5	40	20	7	4.35	18	21	35.50	55.0	75.0	17.4

<sup>1)</sup>Dimension H<sub>2</sub> with cover strip

<sup>2)</sup>For sizes 35 to 55 in accuracy class P, one-piece guide rails up to approx. 4 500 mm in length can be supplied in special cases.

<sup>3)</sup>Preferred dimension T<sub>1s</sub> with tolerances +0.5/-1.0

# Roller guide rail SNS with plastic or steel mounting hole plugs

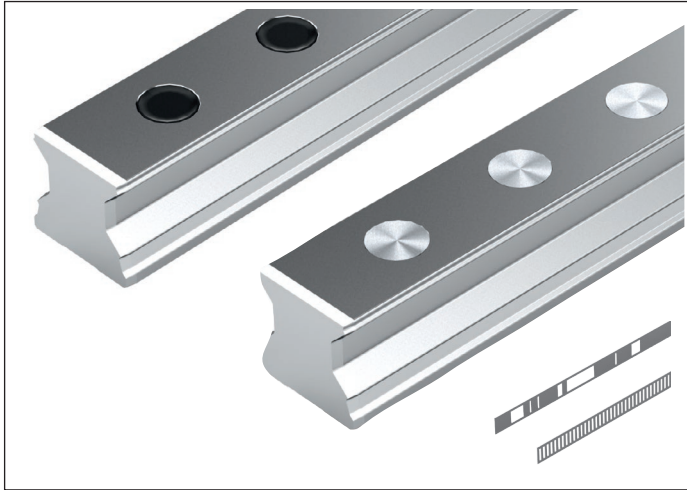

- ▶ For mounting from above:
  - delivered with plastic mounting hole plugs
  - for steel mounting hole plugs (not included, sold separately)
- ▶ With integrated scale

### Notes

- ▶ Note mounting instructions. See the chapter entitled "Mounting instructions".
- ▶ Order mounting tool for steel mounting hole plugs (see Roller Rail Systems catalog).
- ▶ For ordering examples, see the "Ordering examples" section.

### Available versions

Roller guide rails SNS	Size								
	35		45		55		65		
	P	S	P	S	P	S	P	S	
	✓	✓	✓	✓	✓	✓	✓	✓	✓

✓ = Available versions

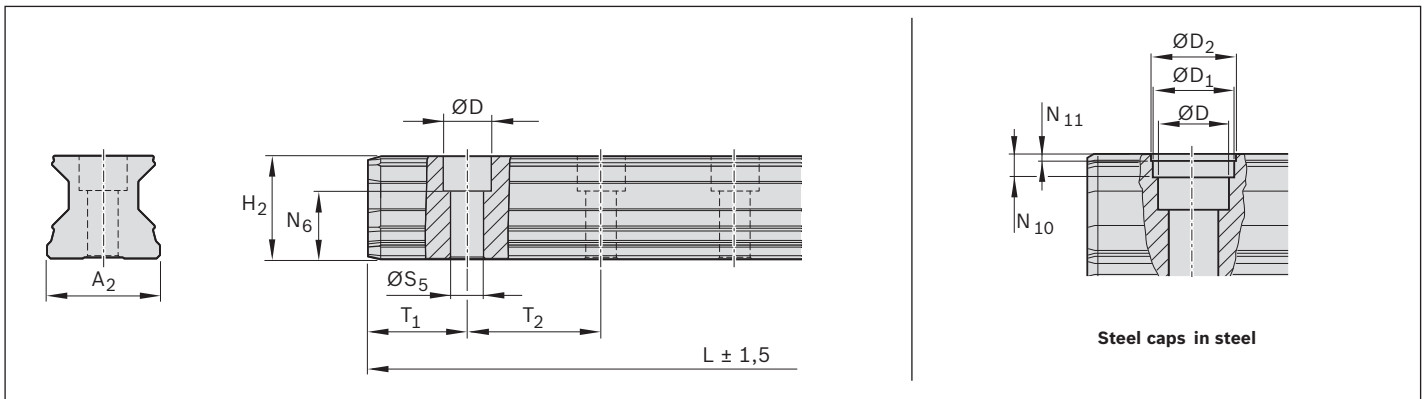

### Dimensions (mm)

Size	A <sub>2</sub>	D	D <sub>1</sub>	D <sub>2</sub>	H <sub>2</sub>	L <sub>min</sub>	L <sub>max</sub> <sup>1)</sup>	N <sub>6</sub> <sup>±0.5</sup>	N <sub>10</sub>	N <sub>11</sub>	ØS <sub>5</sub>	T <sub>1 min</sub>	T <sub>1 S</sub> <sup>2)</sup>	T <sub>1 max</sub>	T <sub>2</sub>	Mass (kg/m)
35	34	15	17.55	18	30.80	270	3996	19.4	3.6	0.90	9	12	18.00	28.0	40.0	6.3
45	45	20	22.55	23	38.80	310	3986	22.4	8.0	1.45	14	16	24.25	36.5	52.5	10.3
55	53	24	27.55	28	47.55	350	3956	28.7	8.0	1.45	16	18	28.00	42.0	60.0	13.1
65	63	26	29.55	30	57.85	420	3971	36.5	8.0	1.45	18	20	35.50	55.0	75.0	17.4

<sup>1)</sup>For sizes 35 to 55 in accuracy class P, one-piece guide rails up to approx. 4 500 mm in length can be supplied in special cases.

<sup>2)</sup>Preferred dimension T<sub>1S</sub> with tolerances +0.5/-1.0

# Cable

**IMS-I / IMS-A**

RKG 0055 connecting cable to Rexroth IndraDrive C/Cs (M17 → EC/ENS Interface (12 V DC))  
 IMS-I: only for I1/1V<sub>SS</sub> 40 μm  
 IMS-A: only for HF/HIPERFACE®



RGS1711 RGS0008

---

RKG 0057 extension cable (M17 → M17)



RGS1711 RGS1732

---

RKG 0058 extension cable (open cable ends)



RGS1711 Flying leads

---

RGS 1711 single connector for self-assembly M17



**IMS-A**

RKG 0071 connecting cable, e.g. for Siemens SME25/125 (M17 → M23, 17 pin, male)



RGS1711

**IMS-I**

RKG 0056 connecting cable to Rexroth IndraDrive C (M17 → EN2 Interface (5 V DC))



RGS1711 RGS0009

---

RKG 0060 extension cable (M17 → M23, 12 pin, male)



RGS1711

---

RKG 0061 connecting cable, e.g. for Siemens SME20/120 (M17 → M23, 12 pin, male)



RGS1711

**Cable lengths**

Length (m)	0.5	2	3	5	8	10	15	20
<b>Cable</b>	<b>Part number</b>							
<b>RKG 0055</b>	R911376423	R911341075	R911341076	R911342688	R911342689	R911347202	R911347204	R911347205
<b>RKG 0056</b>		R911342690	R911341069	R911342691	R911341071			
<b>RKG 0057</b>	R911344382	R911342692	R911341134	R911342693	R911342694	R911369771	R911341135	R911341136
<b>RKG 0058</b>		R911342695	R911341110	R911342696	R911342684	R911347720	R911347721	R911347722
<b>RKG 0060</b>	R911341555	R911343305	R911346280	R911346281		R911346283	R911346284	R911346285
<b>RKG 0061</b>	R911341146	R911343303	R911375949	R911370245				R911377043
<b>RKG 0071</b>	R911373025	R911374436	R911376265	R911374437		R911376266		R911376267
<b>Connection plug</b>								
<b>RGS 1711</b>	R911342383							

Other cable lengths on request

For further technical data/cable description see instructions for electrical interfaces IMS R320103166.

**Maximal cable length  
for IMS-I****For connection to Rexroth drive controller IndraDrive:**

Encoder interface EC (12 VDC supply): maximum length is 75 m. Encoder interface EN2 interface (5 VDC supply): maximum length is 50 m.

**For connection to other makes of evaluation electronics:**

Signal type I1 (1 V<sub>SS</sub>, current consumption 300 mA):

Voltage drop over 75 m cable length is 2.05 V, i.e., the encoder supply voltage for the evaluation electronics must be settable to at least 6.8 V (e.g. by sense-control).

Signal type I2, I3, I4 (TTL, current consumption 350 mA):

Voltage drop over 75 m cable length is 2.30 V, i.e., the encoder supply voltage for the evaluation electronics must be settable to at least 7.05 V (e.g. by sense-control).

**Maximal cable length  
for IMS-A**

Interface	Length (m)	Clock rate (MHz)
HF	75	–
SSI	10	2.00
	48	1.00
	74	0.75
DQ	in accordance with Siemens specification	
FN	48 m (when using FANUC cable LX660-4077-T321)	

**Please note that the cable length can additionally be limited by:**

- ▶ Plug-and-socket connections (> 2 pcs.)
- ▶ EMC behavior

Be sure to take note of the information in the project planning instructions for IndraDrive drive control units and the EMC project planning.

The overall length of the pre-assembled cables is measured inclusive of the connectors.

**Data for encoder cables REG0011**

RoHS	compliant with EU directive 2002/95/EC
AWM Style (UL)	20233
Diameter	10.0 <sup>±0.3</sup> mm
Cable sheath material	PUR
Cable sheath color	RAL2003 (orange)
Spec. cable weight	0.027 kg/m
Oil resistance	EN 60811-2-1 and EN 50363-10-2
Burning behavior	UL 758, section 40, Cable Flame Test Section 1061 as per UL 1581 and CSA C22.2 No. 210-05 Sec. 8.8.2. Test according to DIN EN 60332-1-2
Bending cycles	5 million
Bending radius for flexing installation	75 mm
Bending radius for fixed installation	40 mm

More information on connectors, cables, see documentation “Rexroth connection cable IndraDrive and IndraDyn” DOK-CONNEX-CABLE\*INDRV-CA03-DE-P, R911322948 de-DE, 24.04.2013.

**Cable for DRIVE-CLiQ**

For IMS with interface option “DQ” (DRIVE-CLiQ) we recommend MOTION-CONNECT DRIVE-CLiQ-lines with M12-connector for direct measuring systems from the Siemens accessories range.

**Cable for FANUC αi**

For IMS with the interface option “FN” (FANUC) we recommend the FANUC cable: LX660-4077-T321

# Safety instructions

## General notes

- ▶ Combinations of different accuracy classes

Combining guide rails and runner blocks of different accuracy classes results in different tolerances for dimensions H and A3. See relevant main catalog.

## Intended Use

Rail systems are linear guides capable of absorbing forces from all transverse directions and moments about all axes.

Rail systems are intended exclusively for guiding and positioning tasks when installed in a machine.

The integrated measuring system (IMS for short) is an assembly. The IMS consists of components for precise linear movements and incremental measurements of linear displacement. The product may be used in accordance with the technical documentation (product catalog) for the following purposes:

- ▶ as a direct linear position sensing system in industrial environments (woodworking, laser welding, laser cutting, metal cutting and metal forming machine tools).
- ▶ as a linear encoder in applications with a linear motor.
- ▶ in interpolating axes in machine tools.
- ▶ in measuring machines within the scope of the achievable accuracy.
- ▶ for connection to display units, evaluation electronics for PCs and drive controllers.

The product is intended exclusively for professional use and not for private use.

Use for the intended purpose also includes the requirement that you must have read and understood the product documentation completely, in particular these "Safety instructions".

The product is exclusively intended for incorporation into a final machine or system or for assembling with other components to build a final machine or system.



The permitted operating conditions are determined by the individual components.

## Misuse

Use of the product in any other way than as described under "Intended use" is considered to be misuse and is therefore not permitted.

The product may only be used in applications or environments constituting a danger to the health and life of persons if this use – for example, in potentially explosive atmospheres covered by ATEX regulations – has been expressly specified and permitted in the product documentation.

Bosch Rexroth AG will not accept any liability for injury or damage caused by misuse of the product. The risks associated with any misuse of the product shall be borne by the user alone.

Misuse of the product includes:

- ▶ the transport of persons
- ▶ use in potentially explosive atmospheres
- ▶ use in direct contact with unpacked foodstuffs
- ▶ use in liquids
- ▶ use as a safety component, either mechanical or electrical
- ▶ use in environments with increased radioactivity
- ▶ use with clamping and braking units

## General Safety Instructions

- ▶ The safety rules and regulations of the country in which the product is used must be complied with.
- ▶ All current and applicable accident prevention and environmental regulations must be adhered to.
- ▶ The product may only be used when it is in technically perfect condition.
- ▶ The technical data and environmental conditions stated in the product documentation must be complied with.

- ▶ The product must not be put into service until it has been verified that the final product (for example a machine or system) into which the product has been installed complies with the country-specific requirements, safety regulations and standards for the application.
- ▶ Rexroth rail systems may not be used in zones with potentially explosive atmospheres as defined in the ATEX directive 94/9/EC.
- ▶ Rexroth rail systems must never be altered or modified. The user may only perform the work described in the “Quick user guide” or the “Mounting instructions for ball- or roller rail systems”.
- ▶ The product is never allowed to be disassembled.
- ▶ At high travel speeds a certain amount of noise is caused by the product. If necessary, appropriate measures should be taken to protect hearing.
- ▶ The special safety requirements for specific sectors (e.g. crane construction, theaters, food technology) set forth in laws, directives and standards must be complied with.
- ▶ In all cases, the provisions of the following standard should be noted and followed. DIN 637, safety regulations for dimensioning and operation of profiled rail guides with recirculating rolling elements.

## Directives and standards

Rexroth rail systems are suitable for dynamic linear applications requiring reliability and high precision. The machine tool industry and other sectors must observe a series of standards and directives. These requirements can vary significantly worldwide. It is therefore essential to understand the legislation and standards that apply in each particular region.

### **DIN EN ISO 12100**

This standard describes the safety of machinery – general principles for design, risk assessment and risk reduction. It gives a general overview and contains a guide to the major developments governing machines and their intended use.

### **Directive 2006/42/EC**

The European machinery directive describes the basic safety and health requirements for the design and manufacture of machinery. The manufacturer of a machine or his authorized representative has a duty to ensure that a risk assessment has been performed in order to determine the health and safety requirements which have to be fulfilled for that machine. The machine must be designed and built taking into account the results of the risk assessment.

### **Directive 2001/95/EC**

This directive covers general safety requirements for any product placed on the market and intended for consumers, or likely to be used by consumers under reasonably foreseeable conditions, including products that are made available to consumers in the context of service provision for use by them.

### **Directive 85/374/EEC**

This directive concerns the liability for defective products and applies to industrially manufactured movable objects, irrespective of whether or not they have been incorporated into another movable or immovable object.

### **REGULATION (EC) No. 1907/2006 (REACH)**

This regulation relates to restrictions on the marketing and use of certain dangerous substances and preparations. “Substances” means chemical elements and their compounds as they occur in the natural state or as produced by industry. “Preparations” means mixtures or solutions composed of two or more substances.

# Ordering example for ball rail system IMS-I

## Ball runner block (KWD)

I	M	S	2	I	-	K	W	D	-	0	2	0	-	F	N	S	-	C	2	-	P	-	S	S	-	R	-	R	-	I	1	-	A	-	1	0	0	-	D
										1				2				3			4		5		6		7		8		9				10				11

Ordering data			
Feature	Designation		Description
	IMS2I-KWD	Version	Ball runner block with mounted scanner (incremental)
1	020	Size	Size 20
2	FNS	Format	Flanged, normal, standard height
3	C2	Preload class	Preload class C2
4	P	Accuracy class	Precision
5	SS	Seal	Standard seal
6	R	Ball chain	with ball chain
7	R	Scanner mounting side	Scanner mounted on the right side
8	I1	Interface	1 V <sub>SS</sub> 40 µm
9	A	Connector type	RGS 1722
10	100	Cable length	Cable length 1 m
11	D	Documentation	Standard documentation

## Ball guide rail (KSA)

I	M	S	2	I	-	K	S	A	-	0	2	0	-	S	N	S	-	P	-	M	A	-	A	B	-	1	-	R	2	-	A	3	-	D
										1				2				3			4		5		6		7		8				9	

Ordering data			
Feature	Designation		Description
	IMS2I-KSA	Ball guide rail with scale	Ball guide rail with scale
1	020	Size	Size 20
2	SNS	Format	Slimline, normal, standard height
3	P	Accuracy class	Precision
4	MA	Fastening	Mounting from above
5	AB	Cover	With cover strip and protective end caps
6	1	Number of sections	One-piece guide rail
7	R2	Coding	2 reference marks
8	A3	Accuracy class scale	3 µm
9	D	Documentation	Standard documentation

Rail length 1750 mm

T1 = 35 mm

R1 = 500 mm

R2 = 1500 mm

R3 = -

R4 = -

R5 = -

### Necessary ordering data:

IMS2I-KWD-020-FNS-C2-P-SS-R-R-I1-A-100-D

IMS2I-KSA-020-SNS-P-MA-AB-1-R2-A3-D

Rail length : 1750 mm

T1 : 35 mm

R1 : 500 mm

R2 : 1500 mm

R3 : -

R4 : -

R5 : -



# Ordering example for roller rail system IMS-A

## Roller Runner Block (RWD)

I	M	S	2	A	-	R	W	D	-	0	3	5	-	F	N	S	-	C	2	-	S	-	D	S	-	0	-	R	-	S	1	-	A	-	1	0	0	-	D
										1				2				3			4			5		6		7		8		9			10				11

Ordering data			Description
Feature	Designation		
	IMS2A-RWD	Version	Roller runner block with mounted scanner (absolute)
1	035	Size	Size 35
2	FNS	Format	Flanged, normal, standard height
3	C2	Preload class	Preload class C2
4	S	Accuracy class	Super precision
5	DS	Seal	Double-lipped seal
6	0	Roller chain	Without roller chain
7	R	Scanner mounting side	Scanner mounted on the right side
8	S1	Interface	SSI 10 µm
9	A	Connector type	RGS 1722
10	100	Cable length	Cable length 1 m
11	D	Documentation	Standard documentation

## Roller guide rail (RSA)

I	M	S	2	A	-	R	S	A	-	0	3	5	-	S	N	S	-	S	-	M	A	-	A	B	-	1	-	A	C	-	A	3	-	D	
										1				2				3			4			5		6		7		8					9

Ordering data			Description
Feature	Designation		
	IMS2A-RSA	Roller guide rail with scale	Roller guide rail with scale
1	035	Size	Size 35
2	SNS	Format	Slimline, normal, standard height
3	S	Accuracy class	Super precision
4	MA	Fastening	Mounting from above
5	w	Cover	With cover strip and protective end caps
6	1	Number of sections	One-piece guide rail
7	AC	Coding	Absolute code band
8	A3	Accuracy class scale	3 µm
9	D	Documentation	Standard documentation

Rail length 1640 mm  
T1 = 20 mm

### Necessary ordering data:

IMS2A-RWD-035-FNS-C2-S-DS-0-R-S1-A-100-D

IMS2A-RSA-035-SNS-S-MA-AB-1-AC-A3-D

Rail length : 1640 mm

T1 : 20 mm

# Mounting instructions / Maintenance instructions

⚠ Always handle the measuring system with great care!

See detailed assembly instructions

- ▶ **R320103262 Integrated measuring system mechanical instructions**
- ▶ **R320103166 Integrated measuring system instructions for electrical interfaces**

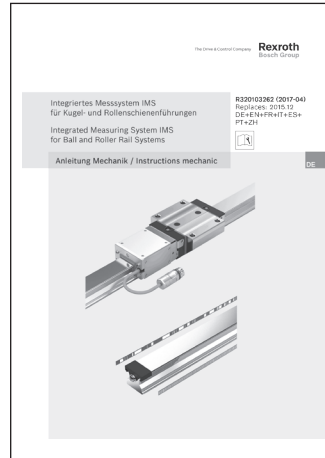

- ▶ **R320103885 Instructions for profiled rail systems**

This documentation is available for download at [www.boschrexroth.com/mediadirectory](http://www.boschrexroth.com/mediadirectory).

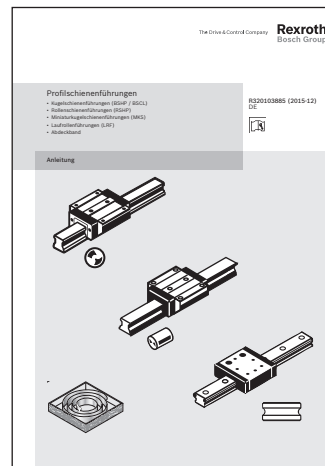

## Lubrication

Rexroth ball rail systems are delivered coated with anti-corrosion oil and with initial greasing. Rexroth roller rail systems are delivered filled with an anti-corrosion agent (sufficient for mounting and start-up). Immediately after mounting the runner blocks (before start-up), make sure the system has sufficient initial lubrication (basic lubrication) with the applicable lubricant. All runner blocks have been designed so that they can be lubricated either with grease or with oil. Ball rail and roller rail systems with measuring system cannot be lubricated through the scanner. Lubricate using the free lube fittings, as indicated by the arrows. For more information on maintenance and lubrication, see the respective sections in the ball rail systems catalog or the roller rail systems catalog.

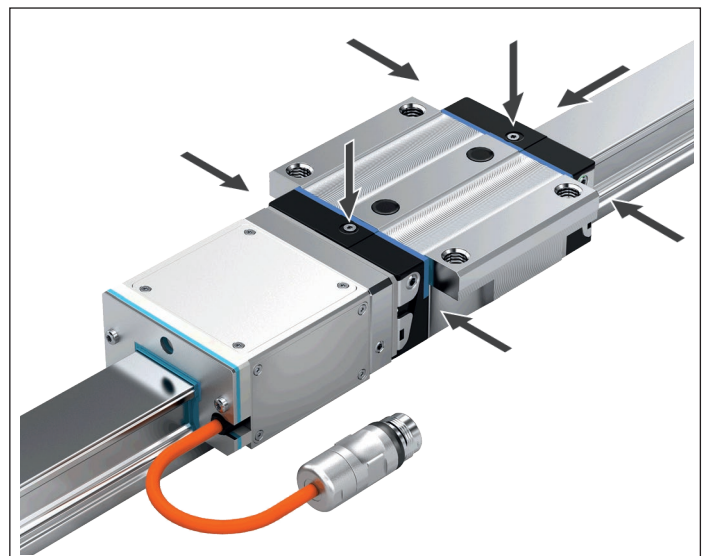

# Inquiry / Order form

**Bosch Rexroth AG**  
**D-97419 Schweinfurt**  
**Telephone (0 97 21) 9 37 -0**  
**Fax (direct) (0 97 21) 9 37-250**

**eShop:**  
<http://www.boschrexroth.com/eshop>



To be completed by customer: Inquiry  / Order

Runner block with scanner

I	M	S	2	-	W	D	-	-	-	-	-	-	-	-	-	-	-	-	1	0	0	-	D						
																			1	2	3	4	5	6	7	8	9	10	11

Guide rail with scale

I	M	S	2	-	S	A	-	-	-	S	N	S	-	-	M	A	-	-	1	-	-	-	-	-	-	-	-	-	D		

Rail length		mm
T1		mm
R1*)		mm
R2*)		mm
R3*)		mm
R4*)		mm
R5*)		mm

Please complete when ordering  
 (refer to ordering examples)

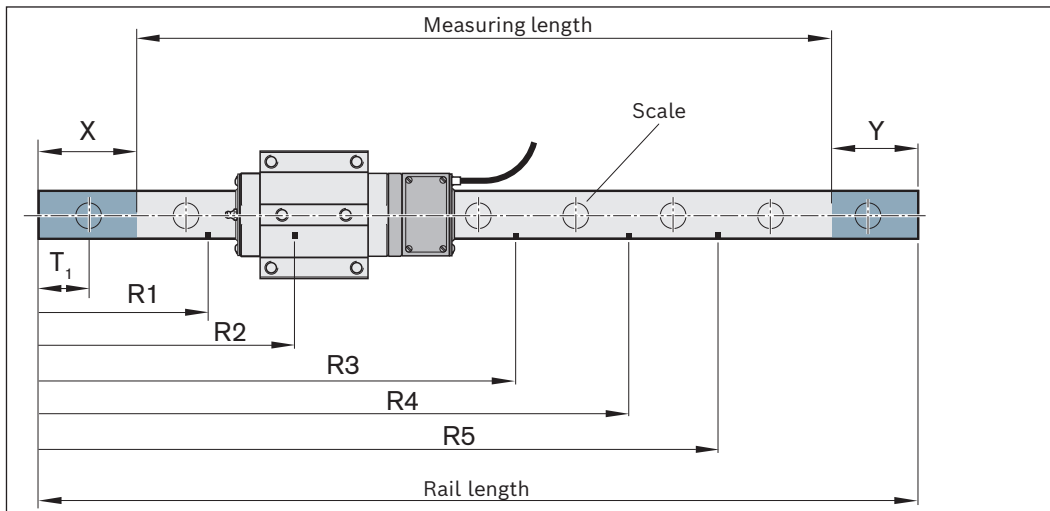

\*) R1 ... R5 Positions of the reference marks (only for IMS-I)

Quantity: \_\_\_\_\_ pieces

Comments: \_\_\_\_\_

**From**

Company: \_\_\_\_\_

Address: \_\_\_\_\_

\_\_\_\_\_

\_\_\_\_\_

Responsible person: \_\_\_\_\_

Department: \_\_\_\_\_

Phone: \_\_\_\_\_

Fax: \_\_\_\_\_

**Bosch Rexroth AG**

Ernst-Sachs-Straße 100  
97424 Schweinfurt, Deutschland  
Tel. +49 9721 937-0  
Fax +49 9721 937-275  
[www.boschrexroth.com](http://www.boschrexroth.com)

**Find your local contact person here:**

[www.boschrexroth.com/contact](http://www.boschrexroth.com/contact)

