

Electromechanical cylinders EMC

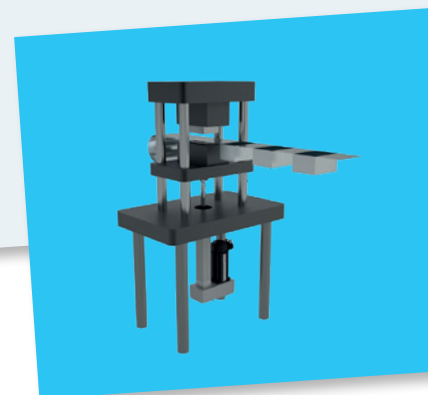
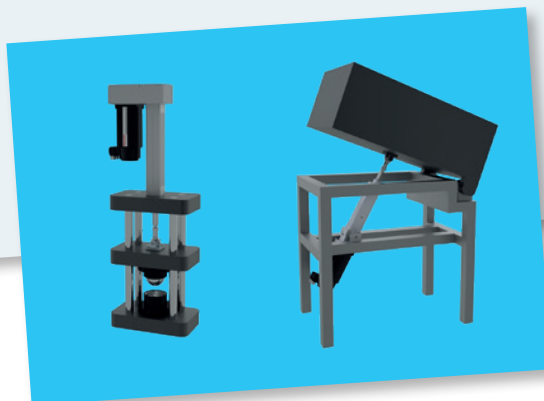
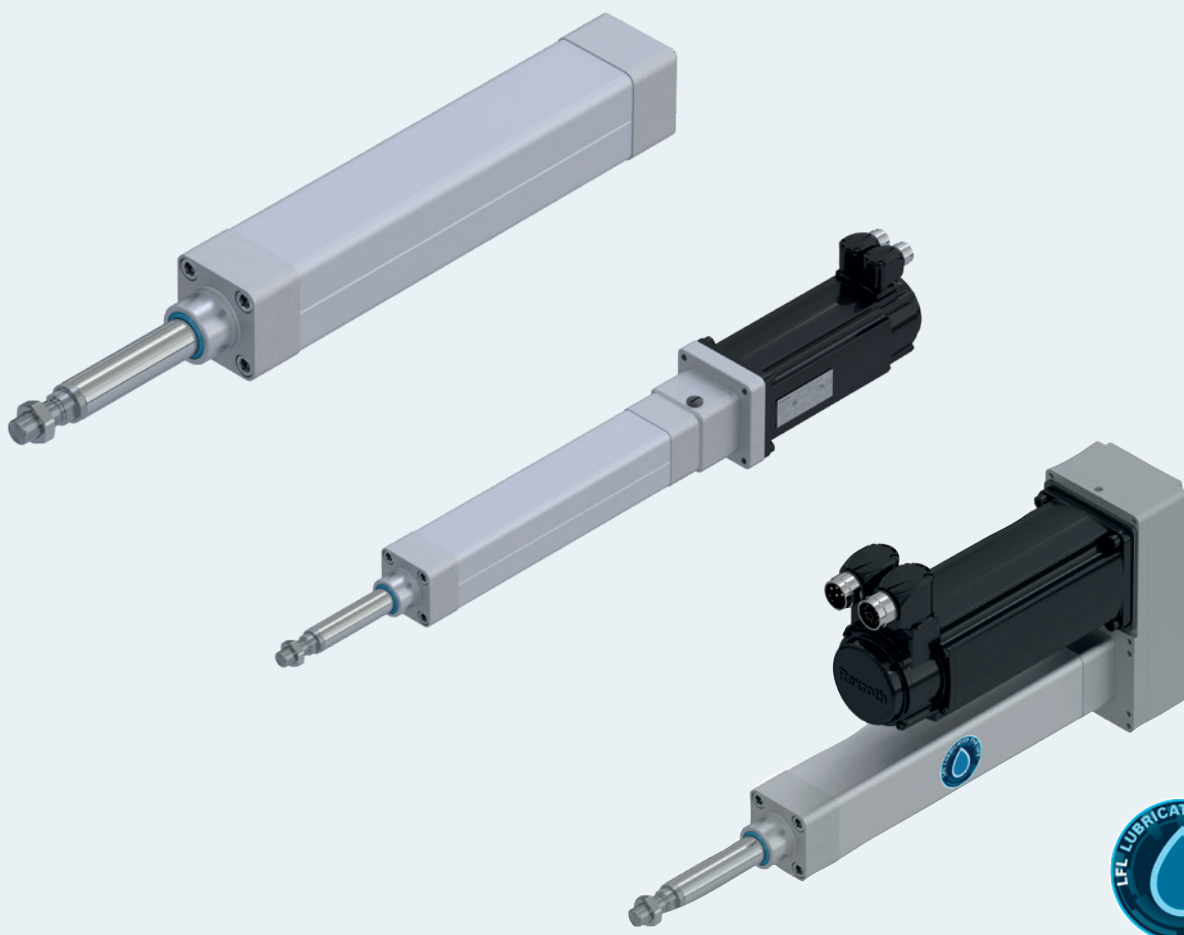

www.boschrexroth.com

Identification system for short product names

Short product name	Example: EMC - 063 - NN - 2
System	E lectro M echanical C ylinder
Size	032 / 040 / 050 / 063 / 080 / 100
Version	NN Normal version XC Extra Capacity
Generation	Product generation 2

Changes/additions at a glance:

- ▶ LFL lifelong lubrication supplemented
- ▶ Information on lubrication versions supplemented
- ▶ MS2N motors revised in chapter „Configuration and ordering“

Contents

Product description	4
Product selection guide	8
Motor-controller combination	12
Product overview	13
Structural design	14
Technical data	16
Axial load on the cylinder mechanics	23
Service life	26
Permissible speeds	27
Load on the piston rod	28
Calculations	30
Calculation principles	30
Drive dimensioning	32
Configuration and ordering	36
EMC 32 – EMC 50	36
EMC 63 – EMC 80	38
EMC 100 – EMC 100XC	40
Dimension drawings	44
Dimension drawing EMC	44
Dimension drawing for motor attachment with flange and coupling	46
Dimension drawing motor attachment with belt side drive	46
Attachments and accessories	48
Fastener	48
Fastening elements	49
Accessories	62
Force sensor	64
Switching system	68
IndraDyn S – servo motors MSM	74
IndraDyn S – servo motors MS2N	76
Service and information	82
Operating conditions and usage	82
Parameterization (start-up)	83
Lubrication and maintenance	84
Documentation	86
Abbreviations	87
Ordering example	88
Inquiry or ordering	90
Further information	91

Product description

A variable and complete system: hygienic, flexible, energy efficient

Its high variability makes the EMC so interesting for many industries and applications. By using the available configuration options, a cheaper, simpler base cylinder can be adjusted to virtually any customer requirement: chemical resistant, with perfect sealing and a high IP enclosure protection class. All these properties ensure a long service life – even under harsh industrial conditions. The powerful EMC always performs very efficiently. The resulting energy saving potential makes it an economical alternative to pneumatic systems.

Structural design

The mechanical system in the electromechanical cylinder is based on proven Rexroth ball screw assemblies in a variety of diameter and lead combinations. The Rexroth ball screw assembly converts the motor torque into linear motion with high mechanical efficiency. During this process, the piston rod fastened to the screw drive nut is extended and retracted. Both the screw drive nut and the piston rod are guided in the housing and cannot twist.

Optional limit switches prevent damage to the cylinder in operation. A reference point switch is available for the use of incremental encoder systems.

Thanks to grease lubrication, electromechanical cylinders EMC require only minimal maintenance at long intervals.

Advantages

- ▶ High-precision Rexroth ball screw assemblies: for high performance with maximum cost-effectiveness
- ▶ Complete building system with great variability: can be adapted to a wide range of applications
- ▶ A ready to install and turn on system for low design and assembly costs
- ▶ The smart, freely programmable drive system allows the realization of complex travel profiles (parameters for force, position and travel speed can be set as required over the complete working travel range)
- ▶ Optimized lubrication concept: optional connection to a central lubrication system reduces downtime
- ▶ Soundly sealed against dirt and water from the outside and lubrication leakage from the cylinder by selecting the IP65 enclosure protection class option
- ▶ Hygienic design: High resistance to chemicals and cleaning agents by selecting the option IP65 + R (resistant)



Notes on lubrication

- ▶ Liquid grease lubrication prepared for connection to central lubrication systems
- ▶ High operational reliability through automated relubrication
- ▶ Need-based maintenance reduces consumption of lubricant, while ensuring high availability
- ▶ More degrees of freedom as lubrication is not dependent on position and installation location
- ▶ Low-cost unmanned maintenance
- ▶ Observe the "Lubrication position" for relubrication. Further information on this and on lubrication see chapter "Lubrication and maintenance"

Lubrication versions**LSS:**

- ▶ Initial lubrication (standard lubrication) carried out by Bosch Rexroth with Dynalub 510
- ▶ Relubrication using manual grease gun

LCF:

- ▶ Prepared for connection to central lubrication systems for liquid grease (grade NLGI 00 in accordance with DIN 51818) with Dynalub 520
- ▶ Lubrication with liquid grease only via single-line piston distributor system

LPG:

- ▶ With corrosion prevention; relubrication with manual grease gun; basic lubrication required

LHG:

- ▶ Initial lubrication with NSF-H1 grease

LFL:

- ▶ Lifelong lubrication with Mobilith SHC 460 (R913073149)

Application conditions:

- Service life $\leq 15,000$ km
- Average load (F_m / C) ≤ 0.05
- Average linear speed (V_m) ≥ 0.05 m/s

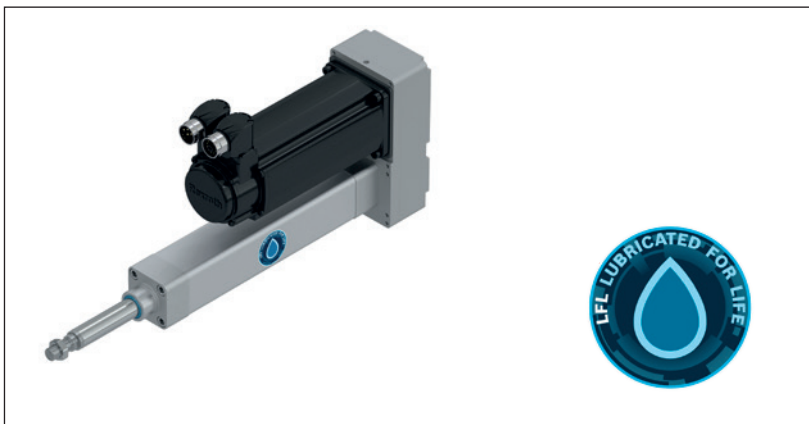

Application areas

Electromechanical cylinders EMC can be used in many application areas. Due to their specific characteristics, they offer advantages in terms of accuracy, dynamics and controllability, and can therefore not only help to shorten cycle times but also to increase flexibility and quality in the manufacturing process. Their space-saving design makes them ideal for use in tightly confined spaces.

Possible application areas are:

- ▶ Servo presses and forming technology
- ▶ Joining technology
- ▶ Thermoforming
- ▶ Injection molding and blow molding machines
- ▶ Woodworking machines
- ▶ Assembly and handling technology
- ▶ Packaging machines and conveyor systems
- ▶ Food processing machines
- ▶ Testing equipment and laboratory applications
- ▶ Special machines

Application examples

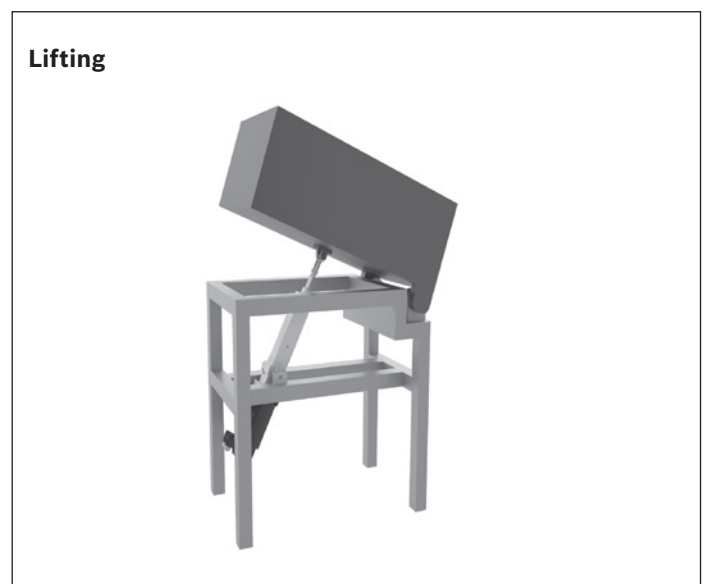
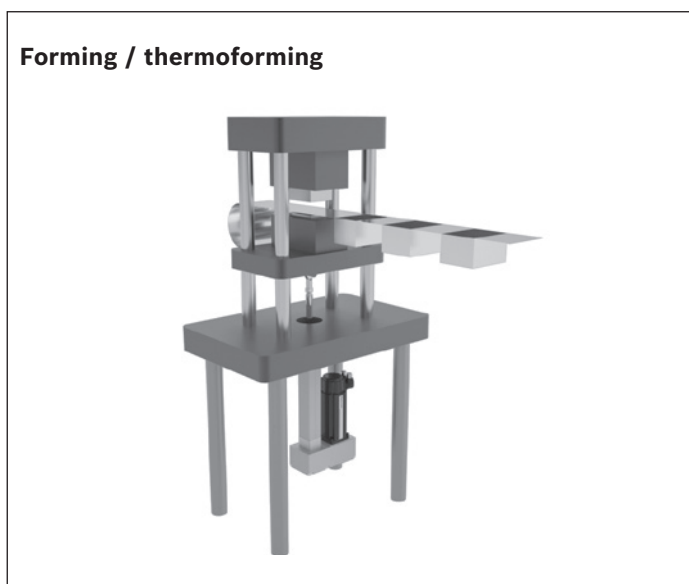

**FASTER, MORE PRODUCTIVE, SMARTER.
THE NEW SMART FUNCTION KIT.**

rexroth
A Bosch Company

PLUG & PRODUCE: MIT DEM NEUEN SMART FUNCTION KIT

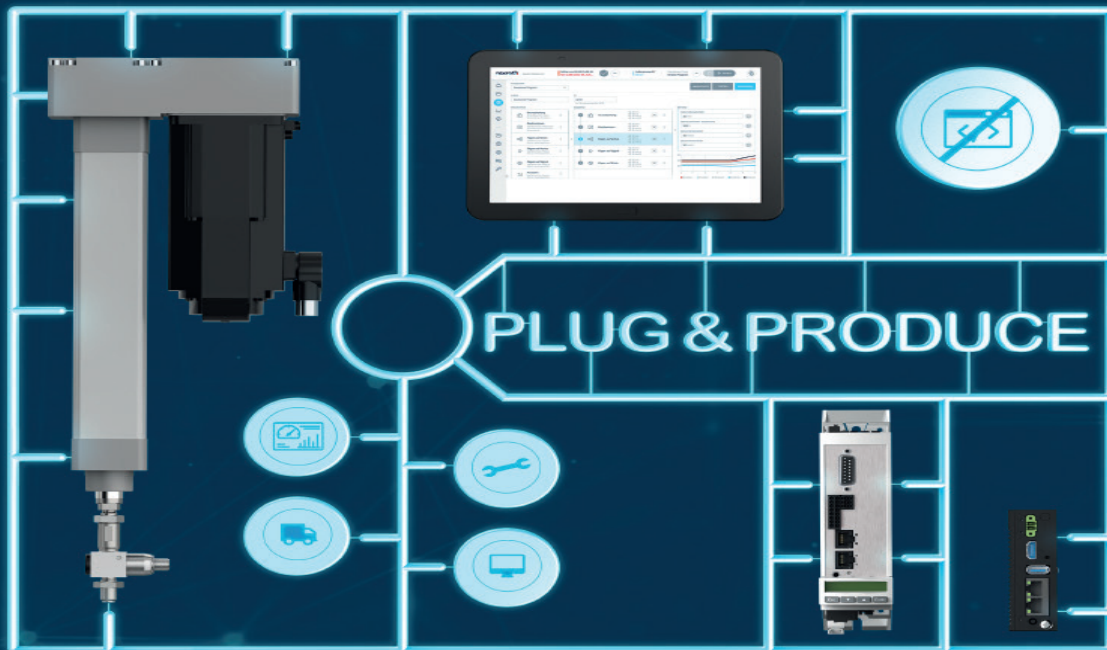

Times are changing. And so are industry requirements and processes. The trend is shifting away from individual products to simple and fast solutions with greater independence. The same applies to all pressing and joining processes in the Factory of the Future. With the new Smart Function Kit, Bosch Rexroth is meeting precisely these requirements for machine and plant manufacturers. It is a simple, fast and efficient package solution for versatile applications with pressing and joining functions. It functions according to the Plug & Produce principle and works with proven Rexroth components as well as browser-based software interfaces for all types of devices. Thanks to simple product selection, short delivery times as well as fast start-up and process configuration, the time spent on engineering can be reduced by up to 95%. Further information at:

<https://www.boschrexroth.com/en/xc/products/product-groups/linear-motion-technology/news/smart-function-kit/index>

Product selection guide

To make sure your electromechanical solution delivers optimal performance, both technically and economically, the right decisions have to be made as early as the planning phase. The following key parameters have a decisive influence on the choice of system and its structural design:

- ▶ Load
- ▶ Dynamics
- ▶ Geometry
- ▶ Environmental and installation conditions

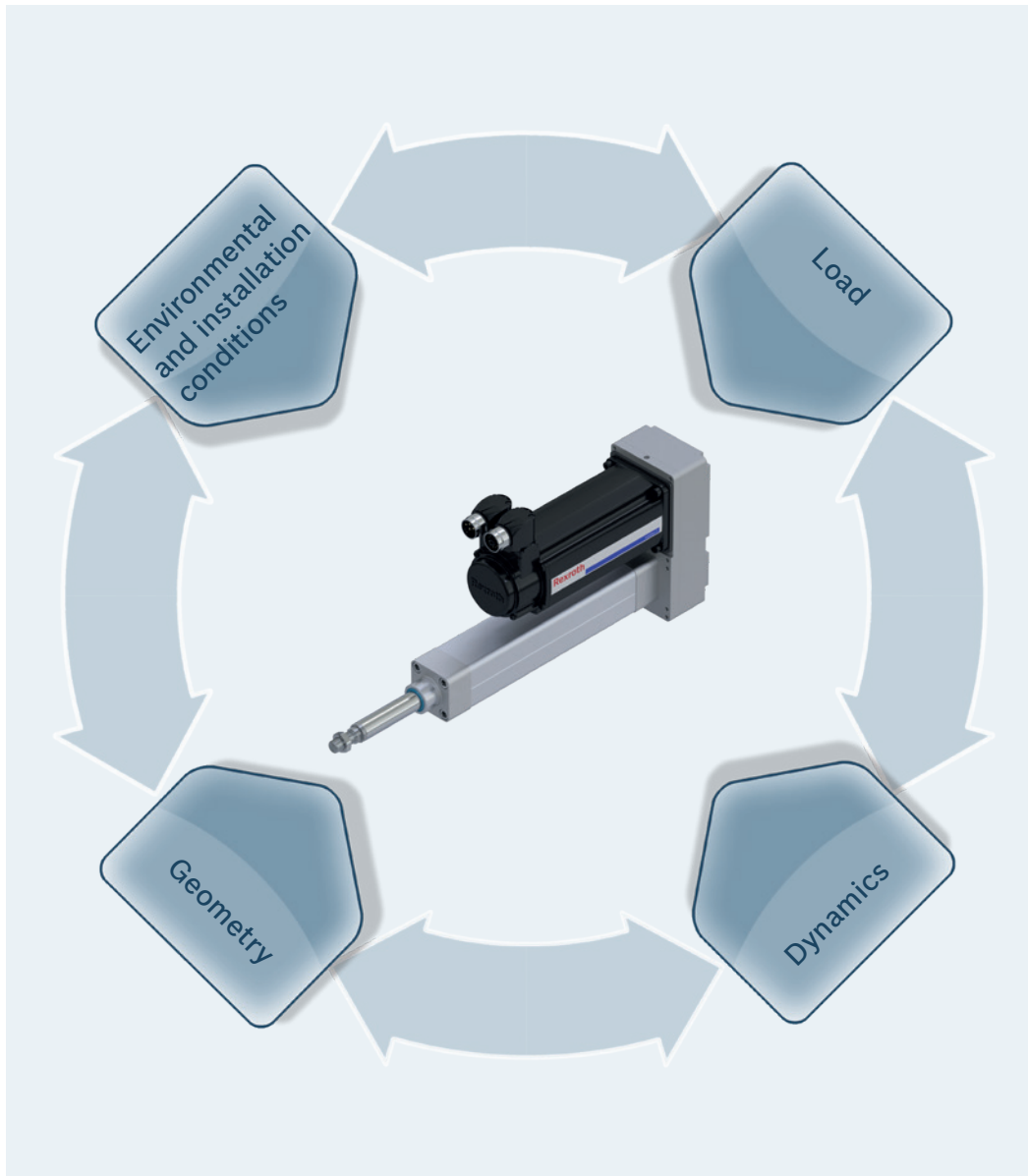

Load

- ▶ Process force
- ▶ Masses
- ▶ Duty cycle
- ▶ Service life requirement
- ▶ etc.

Dynamics

- ▶ Acceleration
- ▶ Travel speed
- ▶ Cycle time
- ▶ etc.

Geometry

- ▶ Working area
- ▶ Installation space
- ▶ Stroke length
- ▶ Interference contours
- ▶ etc.

Environmental and installation conditions

- ▶ Installation position
- ▶ Fastening options
- ▶ Degrees of freedom
- ▶ Temperature
- ▶ Humidity
- ▶ Contamination
- ▶ Vibration and shocks
- ▶ etc.

An electromechanical cylinder EMC that is optimal for your needs in just six steps

Electromechanical cylinders EMC offer higher dynamics and precision, better controllability, and greater mechanical efficiency than the majority of fluid-power drives (e.g. hydraulic cylinders). It is particularly important to fully define application requirements in advance because of the special characteristics compared to fluid-driven technology.

To find the most cost-efficient solution for your application, the following input parameters should be known:

1. Loads

An EMC solution that is both economical and reliable can be found when the loads (process forces and masses) are known as accurately as possible. Along with the maximum force in the application, it is important to also state changing forces over the stroke so that the average load over the entire cycle can be determined. This average load forms the basis for the service life calculation.

Large safety factors for the force required, as are common in some fluid-power applications, should be avoided so that the axis is not over-sized. A differentiation also needs to be made between static load (cylinder at standstill) and dynamic load (during feed motion).

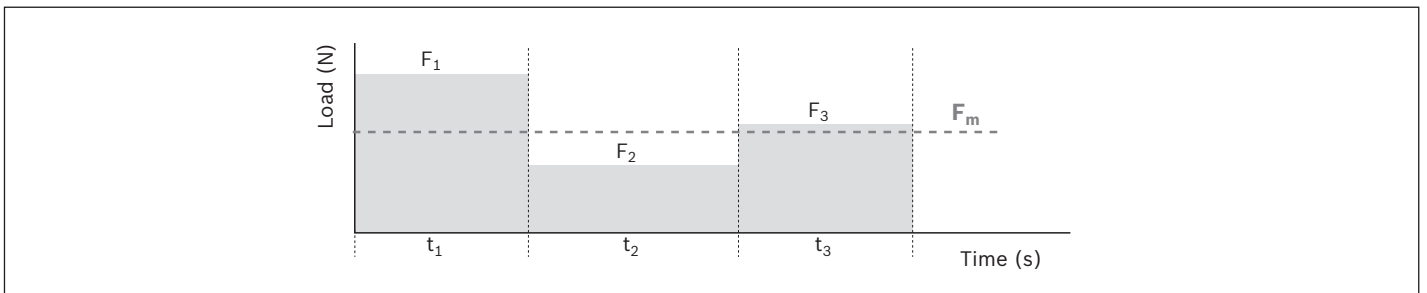

2. Duty cycle

The duty cycle is the percentage ratio of operating time to total cycle time. The duty cycle is an important input parameter for both the estimation of the total service life of the cylinder and for the thermal assessment of cylinder and motor.

Pause times should always be stated in the calculation as well.

$$ED = \frac{t_B}{t_B + t_P} \cdot 100\%$$

ED = Duty cycle (%)
 t_B = Operating time (s)
 t_P = Pause time (s)

Product selection guide

3. Total cycle

By stating the acceleration and linear speeds as accurately as possible or the necessary cycle time and the travel range, it is possible to adapt the complete drive chain to maximize results for the application.

The EMC and drive can be selected so that requirements are met precisely and efficiently.

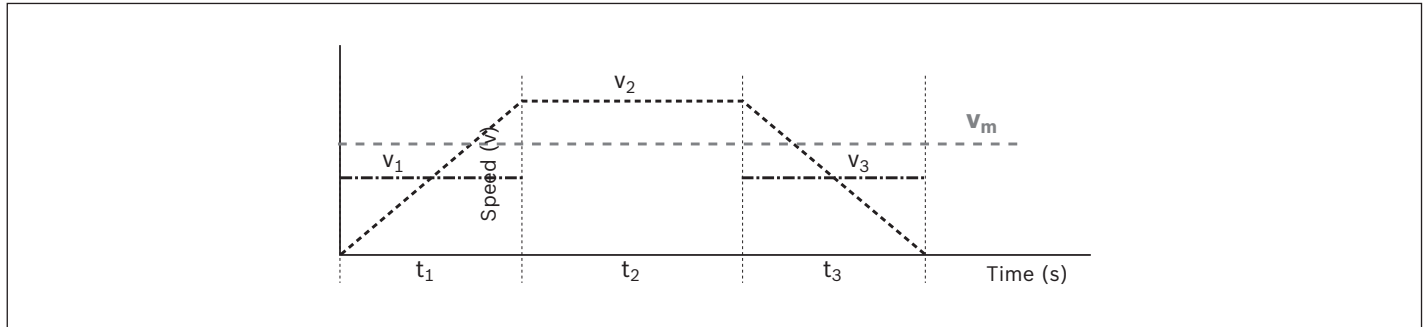

4. Integration in the machine

Transverse forces on the piston rod and alignment errors during assembly can shorten the service life of the electromechanical cylinder EMC.

During fastening, it must be ensured that the cylinder is mounted free of distortive stresses and heavy transverse loads are absorbed by an external guideway.

In addition, the type of attachment and the EMC fastening element have an effect on the maximum permissible axial load. (see section "Axial load" in the chapter "Technical data", see also "Fastening elements").

For an extensive and optimally balanced range of fastening elements, please refer to chapter "Attachments and accessories".

5. Travel range and overall dimensions

Determine the necessary operating stroke in your application. As electromechanical cylinders EMC must not be allowed to travel right up to the mechanical end stop, it is important to add excess travel (s_e) to both ends of the effective operating stroke (s_{eff}). This maximum travel range (s_{max}) is the parameter to be stated when ordering the cylinder.

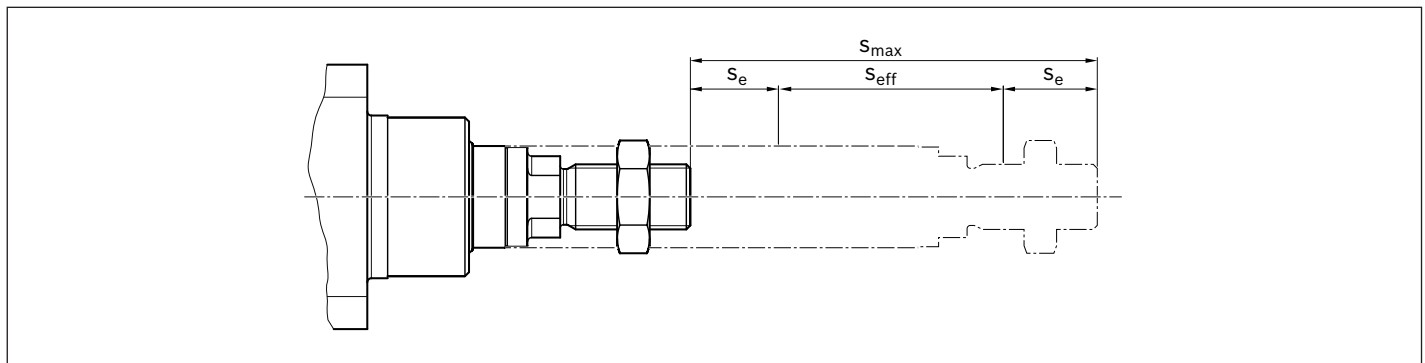

For structural design reasons, the overall length of the cylinder is greater than the maximum travel range (s_{max}), as it includes the length of components such as the screw drive nut and the bearings (represented by L_{ad}), in addition to the travel range. The dimension L_{ZS} describes the position of the piston rod in the retracted position.

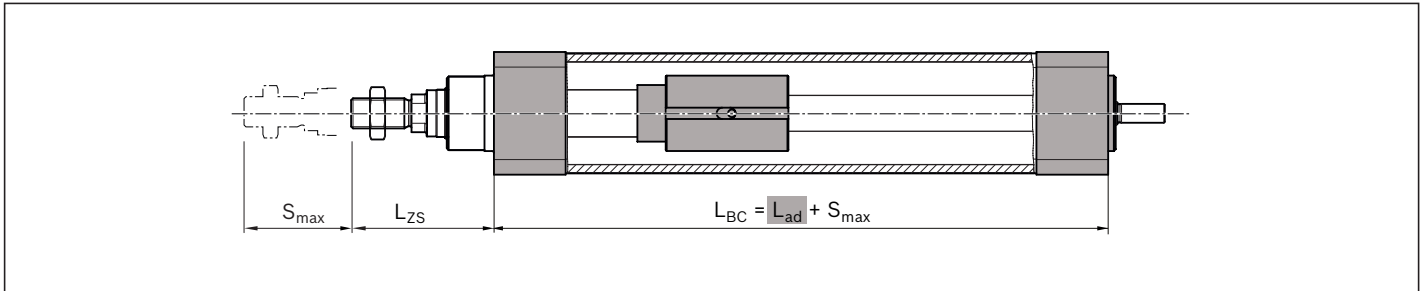

The cylinder can be adapted to the available installation space by mounting the motor as an extension to the axis (flange and coupling) or parallel to the axis (belt side drive). The type of motor attachment chosen also has an effect on the technical performance data and the selectable fastening methods.

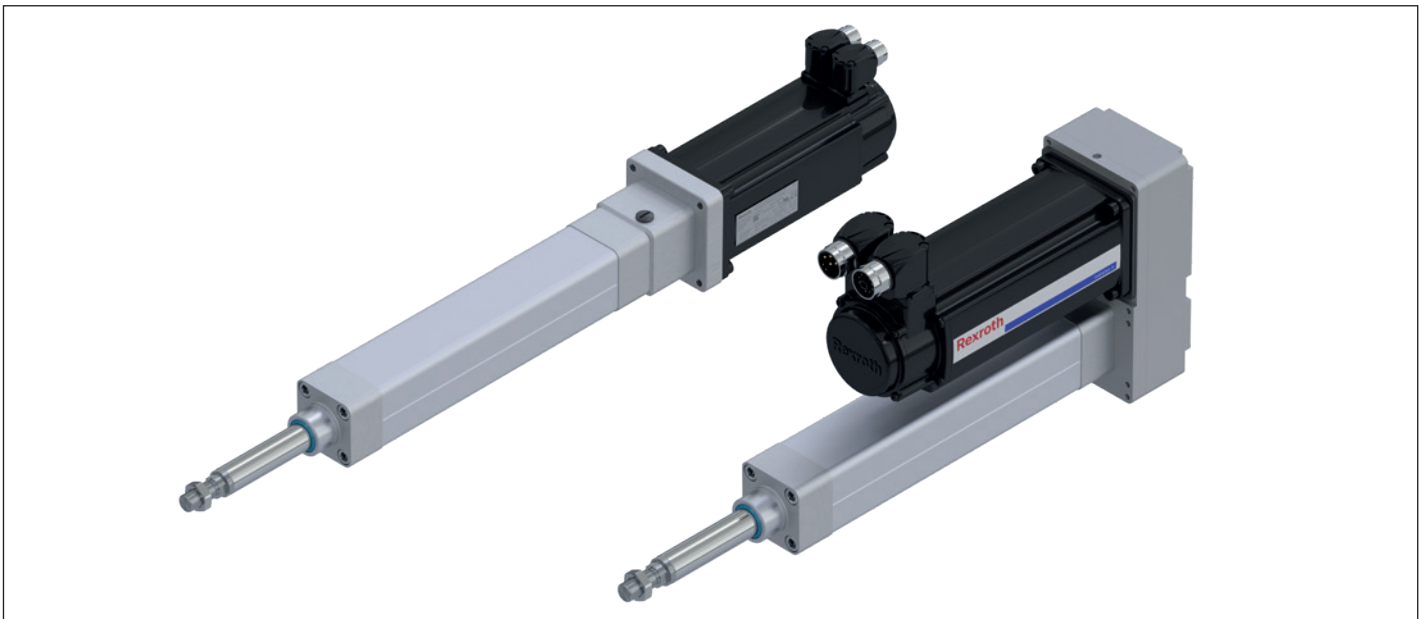

6. Ambient conditions

The environment in which a cylinder is operated can have a significant effect on its service life. Both very high and very low temperatures can affect seals, lubrication and the performance of the motor. Abrasive dirt and chemicals can damage the seals and ultimately cause the screw drive to fail over the long term.

Please ask if your application involves special environmental conditions.

Motor-controller combination

Several motor-controller combinations are available in order to provide the most cost-effective solution for every customer application. When sizing the drive, always consider the motor-controller combination.

Notes on motors and controllers

- ▶ Motors are available with control units and controllers
- ▶ For recommended motor-controller combinations, see chapter "Motors"
- ▶ You can find more information on motors and controllers in the Rexroth catalogs on drive technology at www.boschrexroth.com/mediadirectory.

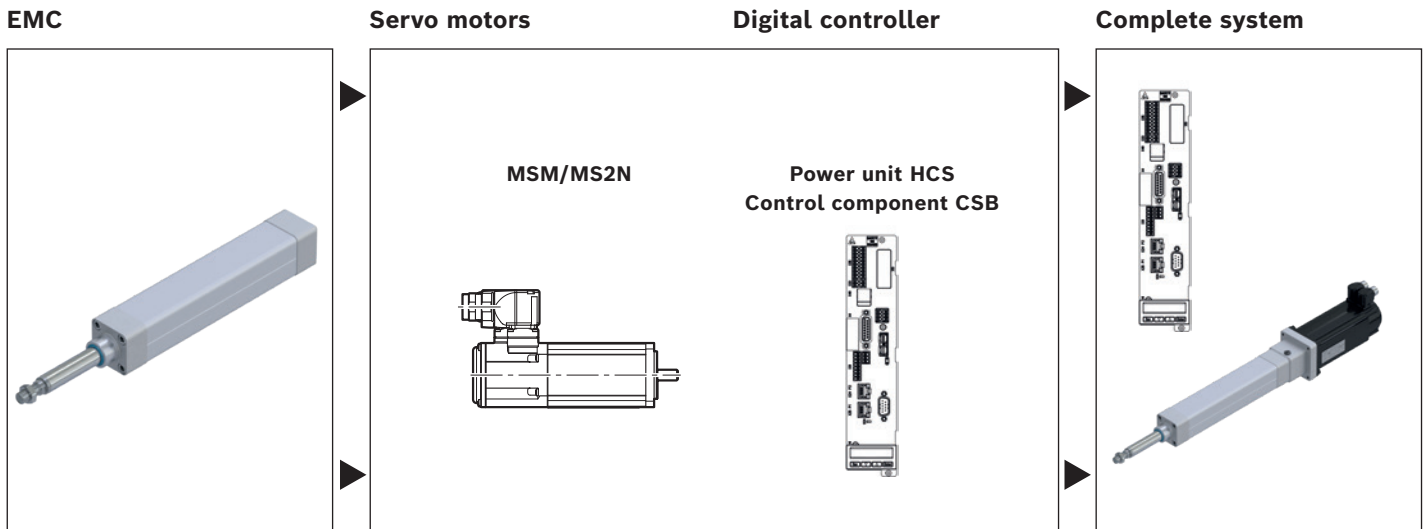

IndraDrive Mi distributed drive system

Control electronics and servo motor in one space-saving unit. The IndraDrive Mi is the ideal solution for applications that depend on minimum space yet require maximum flexibility and cost-effectiveness.

IndraDrive Mi – the new generation of cabinet-free drive technology from Rexroth.

For more information, see "Drive system Rexroth IndraDrive, R999000018".

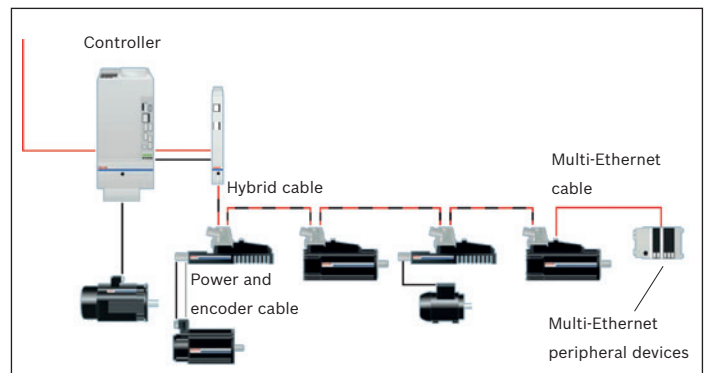

Up to 20 IndraDrive Mi in a chain - these motor-integrated servo drives (KSM) and servo drives close to the motor (KMS) are freely combinable. Via further KCU, additional IndraDrive Mi chains can be integrated.

Product overview

Note on dynamic load rating

In relation to the desired service life, generally speaking an equivalent dynamic axial load of up to about 20% of the dynamic load rating (C) has proven effective. (see also service life graphs in chapter "Technical data".)

Do not exceed the technical data.

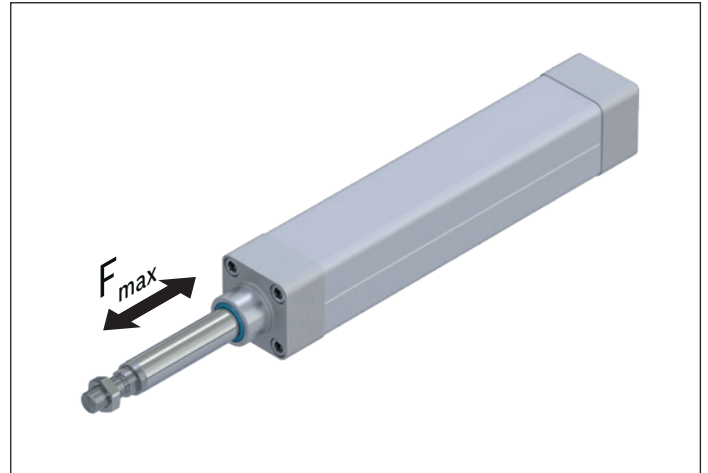

The size designation 32 to 100 is selected according to the piston diameter of an ISO 15552 standard cylinder.

The built-in Rexroth ball screw assemblies have a diameter of 12 mm to 50 mm.

EMC	$d_0 \times P$	C (N)	F_{max} (N)	$s_{max\ zul}$ (mm)	v_{max} (m/s)
32	12x5	4 100	1 200	750	0.57
	12x10	2 700	750		1.13
40	16x5	13 300	4 500	750	0.38
	16x10	10 400	3 000		0.77
	16x16	10 400	2 000		1.23
50	20x5	15 400	7 800	900	0.32
	20x10	15 200	5 500		0.63
	20x20	14 400	3 200		1.27
63	25x5	17 200	15 900	1 200	0.28
	25x10	17 000	14 800		0.55
	25x25	15 900	8 000		1.38
80	32x5	23 300	21 600	1 500	0.25
	32x10	26 000	22 000		0.50
	32x20	21 300	15 000		1.00
	32x32	21 100	10 400		1.60
100	40x5	31 400	29 000	1 500	0.18
	40x10	42 100	29 000		0.37
	40x20	40 900	29 000		0.73
	40x40	40 000	22 900		1.47
100XC	50x10	86 100	56 000	1 500	0.50
	50x20	104 900	50 000		1.00

For short product names, see chapter "Abbreviations".

Structural design

- 1 Hexagon nut
- 2 Piston rod (stainless steel)
- 3 Hex socket head cap screw
(for mounting fastening element
and motor attachments)
- 4 Cover
- 5 Housing
- 6 Bottom
- 7 Screw journal
- 8 Slot for sensor profile
(opposite the lube connection)

Attachments

- 9 Retaining bracket
(for sensor profile)
- 10 Sensor profile
- 11 Motor
- 12 Flange and coupling
- 13 Belt side drive
- 14 Lube connection for lubrication
versions LSS, LCF, LPG, LHG; for
lubrication version LFL: Housing
without lube connection
- 15 Connection for pressure
compensation

Motor flange and coupling

The motor flange is used to fasten the motor to the EMC and as a closed housing unit for the coupling. With the coupling, the drive torque of the motor is transmitted free of distortive stresses on the screw journal of the EMC.

Belt side drive

This configuration results in the shortest possible overall length of the EMC.

The space-saving, closed housing serves as protection for the belt, motor bracket and to connect fastening elements.

Various gear ratios are available:

$i = 1 : 1$

$i = 1 : 1.5$

$i = 1 : 2$

The belt side drive can be mounted in three directions (RV01 to RV03).

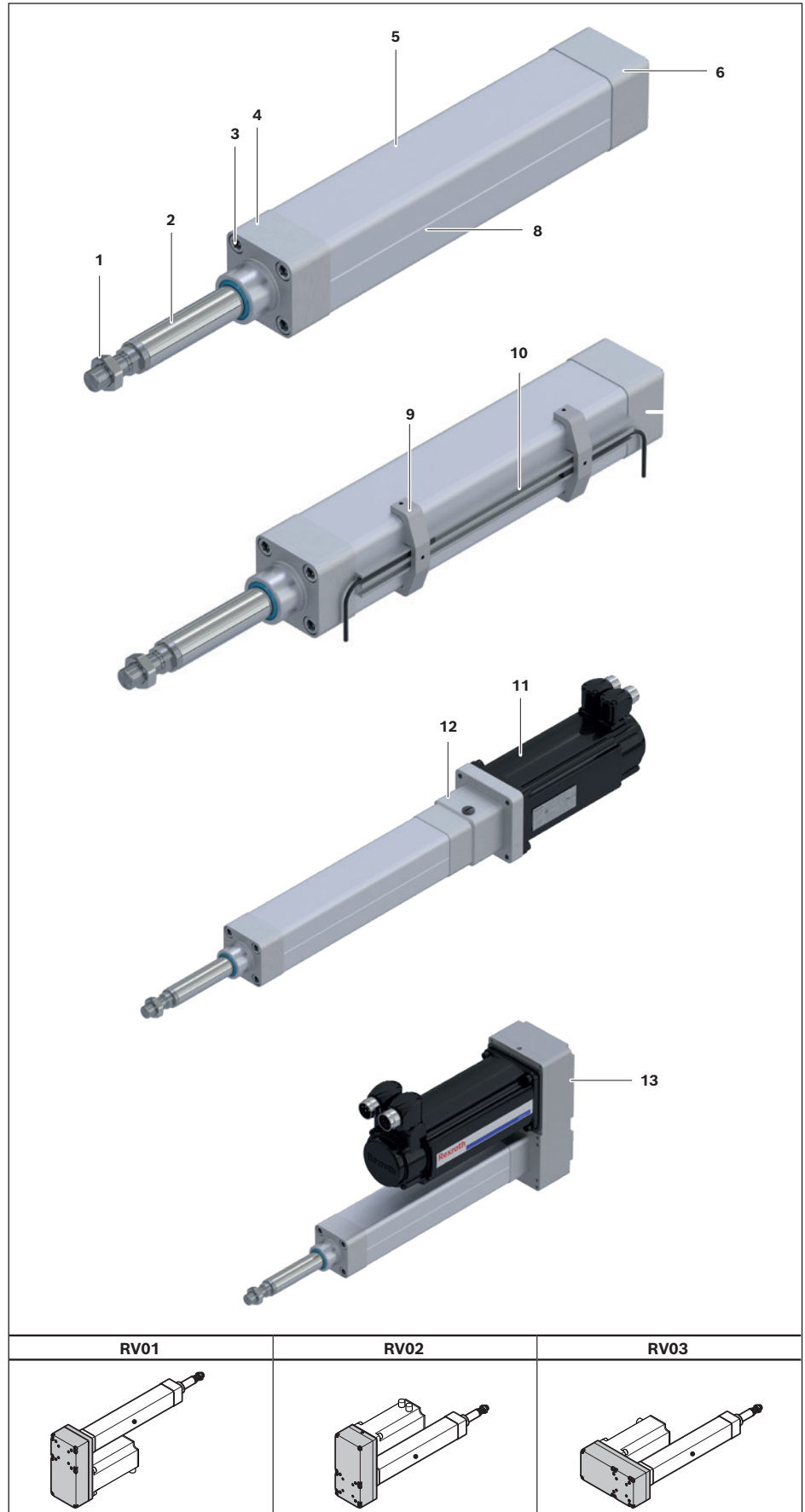

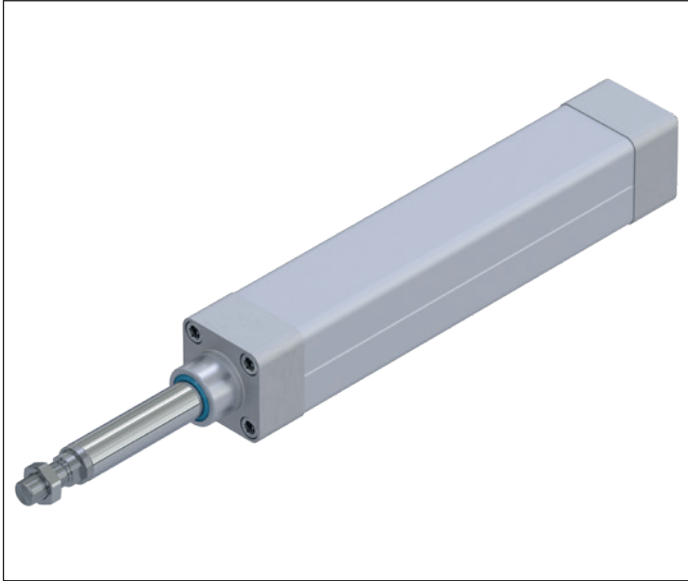

Features at a glance

- ▶ The hygienic design of the EMC with smooth surfaces prevents the formation of dirt and allows for easy cleaning of the cylinder. A sensor profile can be mounted to the housing to allow the use of limit and/or reference switches outside of the aluminum profile.

The EMC is pre-lubricated with standard grease or NSF-H1 grease and is therefore ready for immediate use. Alternatively, the built-in Rexroth ball screw assembly can also be ordered only conserved for initial lubrication by the customer. The EMC can be connected to a central lubrication system with liquid grease. A lube connection is included if the appropriate lubrication option has been selected.

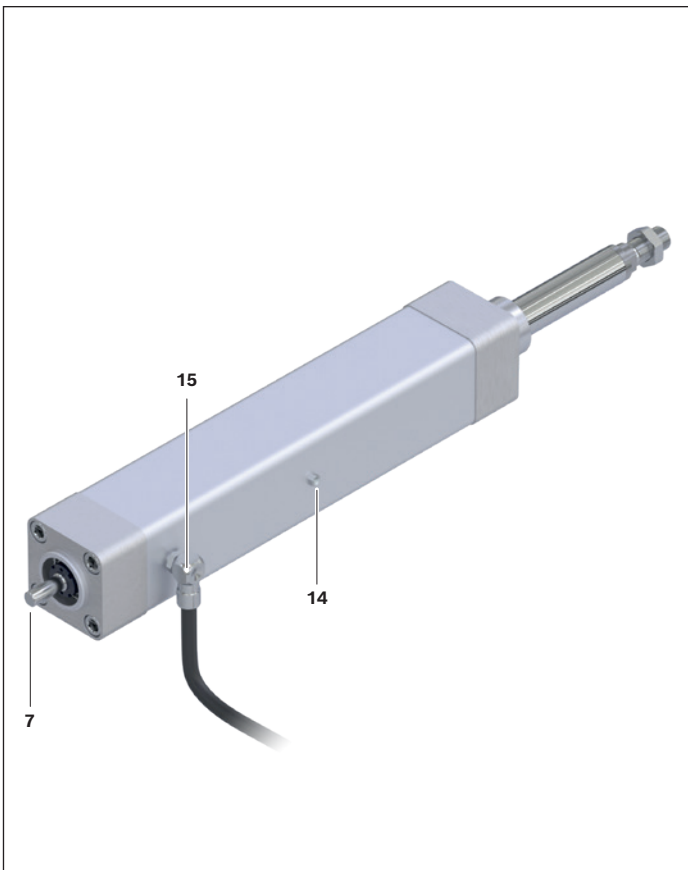

IP65 enclosure protection class

- ▶ Seals between the end caps and the housing and a reinforced seal on the piston rod ensure reliable protection against dust and water ingress. A connection for pressure compensation (15) in the housing prevents underpressure in the cylinder by allowing controlled air flow between interior and environment. The electric cylinder and motor mountings with IP65 fulfill the requirements according to IEC 60 529.

IP65 enclosure protection class +R (resistant)

- ▶ In addition to the benefits of the IP65 rating, this version provides chemical resistant seals between the end caps and the housing, as well as at the piston rod. The lube connection (14), the connection for pressure compensation (15) and the hexagon nut (1) are made from stainless steel. As additional accessories corrosion-resistant plug screws for the hex socket head cap screws in the cover are available.

Technical data

Drive data without motor attachment

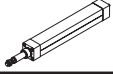
EMC 	d ₀ xP (mm)	C (N)	F _{max} (N)	M _p (Nm)	s _{min} (mm)	s _{max zul} (mm)	v _{max} (m/s)	n _p (min ⁻¹)	a _{max} (m/s ²)	L _{ad} (mm)	M _{RS} (Nm)
32	12x5	4 100	1 200	1.1	30	750	0.57	6 800	50.0	132.00	0.16
	12x10	2 700	750	1.3	40		1.13	6 800	50.0	136.00	0.20
40	16x5	13 300	4 500	4.0	35	750	0.38	4 600	50.0	134.00	0.28
	16x10	10 400	3 000	5.3	45		0.77	4 600	50.0	143.00	0.33
	16x16	10 400	2 000	5.7	65		1.23	4 600	50.0	159.00	0.40
50	20x5	15 400	7 800	6.9	40	900	0.32	3 800	39.8	142.00	0.50
	20x10	15 200	5 500	9.7	60		0.63	3 800	50.0	161.00	0.55
	20x20	14 400	3 200	11.3	80		1.27	3 800	50.0	180.00	0.65
63	25x5	17 200	15 900	14.1	45	1 200	0.28	3 300	28.9	148.00	0.75
	25x10	17 000	14 800	26.2	65		0.55	3 300	50.0	167.00	0.80
	25x25	15 900	8 000	35.4	95		1.38	3 300	50.0	199.00	1.00
80	32x5	23 300	21 600	19.1	50	1 500	0.25	3 000	17.9	163.00	1.20
	32x10	26 000	22 000	38.9	80		0.50	3 000	30.7	187.00	1.30
	32x20	21 300	15 000	53.1	85		1.00	3 000	50.0	195.00	1.40
	32x32	21 100	10 400	58.9	120		1.60	3 000	50.0	230.00	1.60
100	40x5	31 400	29 000	25.7	55	1 500	0.18	2 200	12.2	171.00	2.40
	40x10	42 100	29 000	51.3	70		0.37	2 200	16.8	185.00	2.50
	40x20	40 900	29 000	102.6	90		0.73	2 200	33.0	203.00	2.60
	40x40	40 000	22 900	162.0	145		1.47	2 200	50.0	258.00	2.80
100XC	50x10	86 100	56 000	99.0	90	1 500	0.50	3 000	12.1	316.00	4.00
	50x20	104 900	50 000	176.8	115		1.00	3 000	22.0	338.00	5.00

1) Total axial clearance of the EMC when new

2) Constants for calculating the mass moment of inertia. For formulas, see chapter "Drive dimensioning"

Note:

The travel range can be selected in mm steps between s_{min} and s_{max zul}.

Mass of the EMC

Weight calculation without the motor and without motor attachment

$$m_s = k_g \text{ fix} + k_g \text{ var} \cdot s_{\text{max}}$$

Weight calculation without motor with belt side drive

$$m_s = k_g \text{ fix} + k_g \text{ var} \cdot s_{\text{max}} + m_{\text{sd}}$$

Weight calculation without motor with flange and coupling

$$m_s = k_g \text{ fix} + k_g \text{ var} \cdot s_{\text{max}} + m_{\text{fc}}$$

Moved mass of system

$$m_{\text{ca}} = m_{\text{ca fix}} + m_{\text{ca var}} \cdot s_{\text{max}}$$

Length calculation

$$L_{\text{BC}} = s_{\text{max}} + L_{\text{ad}}$$

	Total axial clearance cylinder ¹⁾ (μm)	$k_{J \text{ fix}}^{2)}$	$k_{J \text{ var}}^{2)}$	$k_{J \text{ m}}^{2)}$	m_s	m_{ca}		
						$k_{g \text{ fix}}$ (kg)	$k_{g \text{ var}}$ (kg/mm)	$m_{ca \text{ fix}}$ (kg)
	10	1.945	0.012	0.633	0.885	0.004	0.311	0.001
	15	2.618	0.013	2.533	0.911	0.004	0.326	0.001
	10	6.616	0.032	0.633	1.255	0.005	0.432	0.001
	15	7.839	0.033	2.533	1.336	0.005	0.481	0.001
	20	11.114	0.040	6.485	1.487	0.005	0.567	0.001
	5	15.815	0.085	0.633	2.115	0.008	0.695	0.001
	10	19.092	0.088	2.533	2.382	0.008	0.838	0.001
	20	27.304	0.095	10.132	2.560	0.008	0.896	0.001
	5	39.693	0.223	0.633	3.018	0.010	1.059	0.002
	10	48.227	0.243	2.533	3.417	0.010	1.291	0.002
	20	76.002	0.242	15.831	4.047	0.010	1.679	0.002
	5	92.538	0.607	0.633	5.185	0.015	1.871	0.003
	10	119.067	0.647	2.533	6.182	0.015	2.495	0.003
	10	145.503	0.665	10.132	6.525	0.015	2.739	0.003
	20	225.036	0.684	25.938	7.610	0.015	3.404	0.003
	5	276.160	1.568	0.633	8.795	0.025	3.249	0.006
	5	291.780	1.369	2.533	9.684	0.025	3.829	0.006
	10	349.478	1.408	10.132	10.479	0.025	4.281	0.006
	20	628.583	1.567	40.528	13.410	0.025	6.166	0.006
	5	1 080,741	3.588	2.533	16.828	0.031	5.292	0.007
	10	1 184,852	3.519	10.132	18.020	0.031	5.994	0.007

Mechanical efficiency $\eta = 0.9$ (for all sizes)

Note:

F_{max} and v_{max} depend on the selected travel range (s_{max}) of the EMC. See the following tables.

Technical data

Drive data for motor attachment via flange and coupling

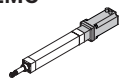
EMC 	d ₀ x P (mm)	for motor	Flange and coupling								a _{max} (m/s ²)
			F _{max} ²⁾ (N)	M _p ²⁾ (Nm)	v _{max} ²⁾ (m/s)	M _{Rs} (Nm)	k _{J fix} ¹⁾	k _{J var} ¹⁾	k _{J m} ¹⁾	m _{fc} (kg)	
32	12 x 5	MSM019B MSM031B MS2N03B	1 200	1.1	0.57	0.16	8.945	0.012	0.633	0.37	
	12 x 10	MSM019B MSM031B MS2N03B	750	1.3	1.13	0.20	9.618	0.013	2.533	0.37	
40	16 x 5	MSM031C MS2N03B MS2N03D	4 500	4.0	0.38	0.28	41.616	0.032	0.633	0.56	50.0
		MS2N04								0.68	
	16 x 10	MSM031C MS2N03B MS2N03D	3 000	5.3	0.77	0.33	42.839	0.033	2.533	0.56	
		MS2N04								0.68	
	16 x 16	MSM031C MS2N03B MS2N03D	2 000	5.7	1.23	0.40	46.114	0.040	6.485	0.56	
		MS2N04								0.68	
50	20 x 5	MSM031C MSM041B MS2N04	7 800	6.9	0.32	0.50	78.815	0.085	0.633	1.10	39.8
		MS2N05								1.13	
	20 x 10	MSM031C MSM041B MS2N04	5 500	9.7	0.63	0.55	82.092	0.088	2.533	1.10	50.0
		MS2N05								1.13	
	20 x 20	MSM031C MSM041B MS2N04	3 200	11.3	1.27	0.65	90.304	0.095	10.132	1.10	
		MS2N05								1.13	
63	25 x 5	MSM041B MS2N05	15 900	14.1	0.28	0.75	249.693	0.223	0.633	1.77	28.9
		MS2N04								1.28	
		MS2N06								1.97	
	25 x 10	MSM041B MS2N05	14 800	26.2	0.55	0.80	258.227	0.243	2.533	1.77	50.0
		MS2N04	10 700	18.9						1.28	
		MS2N06	14 800	26.2						1.97	
	25 x 25	MSM041B MS2N05	8 000	35.4	1.38	1.00	286.002	0.242	15.831	1.77	
		MS2N04	4 300	19.0						1.28	
		MS2N06	8 000	35.4						1.97	

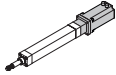
EMC 	d ₀ x P (mm)	for motor	Flange and coupling									
			F _{max} ²⁾ (N)	M _p ²⁾ (Nm)	v _{max} ²⁾ (m/s)	M _{Rs} (Nm)	k _{J fix} ¹⁾	k _{J var} ¹⁾	k _{J m} ¹⁾	m _{fc} (kg)	a _{max} (m/s ²)	
80	32 x 5	MS2N05	21 600	19.1	0.25	1.20	302.538	0.607	0.633	2.29	17.9	
		MS2N06								2.49		
		MS2N07								2.80		
	32 x 10	MS2N05	22 000	38.9	0.50	1.30	329.067	0.647	2.533	2.29	30.7	
		MS2N06								2.49		
		MS2N07								2.80		
	32 x 20	MS2N05	15 000	53.1	1.00	1.40	355.503	0.665	10.132	2.29	50.0	
		MS2N06								2.49		
		MS2N07								2.80		
	32 x 32	MS2N05	10 400	58.9	1.60	1.60	435.036	0.684	25.938	2.29	50.0	
		MS2N06								2.49		
		MS2N07								2.80		
100	40 x 5	MS2N06	29 000	25.7	0.18	2.40	686.160	1.568	0.633	3.77	12.2	
		MS2N07								3.94		
	40 x 10	MS2N06	29 000	51.3	0.37	2.50	701.780	1.369	2.533	3.77	16.8	
		MS2N07								3.94		
	40 x 20	MS2N06	29 000	102.6	0.73	2.60	759.478	1.408	10.132	3.77	33.0	
		MS2N07								3.94		
	40 x 40	MS2N06	21 900	154.9	1.47	2.80	1 038,583	1.567	40.528	3.77	50.0	
		MS2N07								3.94		
	100XC	50 x 10	MS2N07	56 000	99.0	0.50	4.00	1 980,741	3.588	2.533	6.06	12.1
			MS2N10								7.45	
		50 x 20	MS2N07	50 000	176.8	1.00	5.00	2 084,852	3.519	10.132	6.06	22.0
			MS2N10								7.45	

¹⁾ Constants for calculating the mass moment of inertia. For formulas, see chapter "Drive dimensioning"

²⁾ Force or torque and speed can be limited by the motor

Mechanical efficiency $\eta = 0.9$ (for all sizes)

Note:

All data is given for the complete mechanical drive chain (EMC with coupling) at the reference point motor shaft.

F_{max} and v_{max} depend on the selected travel range (s_{max}) of the EMC. See the following tables.

Actual results depend on the selected motor-controller combination.

The motor torque might need to be limited.

For short product names, see chapter "Abbreviations".

Technical data

Drive data for motor attachment via belt side drive

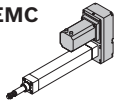
EMC 	d ₀ x P (mm)	i ¹⁾	for motor	Belt side drive													
				F _{max} ³⁾ (N)	M _p ³⁾ (Nm)	v _{max} ³⁾ (m/s)	M _{Rs} (Nm)	k _{J fix} ²⁾	k _{J var} ²⁾	k _{J m} ²⁾	m _{sd} (kg)	a _{max} (m/s ²)					
32	12 x 5	1	MSM019	680	0.6	0.57	0.22	14.2	0.012	0.633	0.55	50.0					
			MSM031B				0.31	45.6			0.95						
			MS2N03B					38.0			0.80						
	12 x 10	1	MSM019	450	0.8	1.13	0.26	14.9	0.013	2.533	0.55						
			MSM031B				0.35	46.3			0.95						
			MS2N03B					38.7			0.80						
40	16 x 5	1	MSM031C	3 100	2.8	0.38	0.43	47.6	0.032	0.633	0.80	50.0					
			MS2N03B					43.5			0.75						
			MS2N04					247.7			1.70						
		1.5	MSM031C	3 100	1.9		0.34	15.4	0.014	0.281	0.75						
			MS2N03B					16.0			0.75						
			MS2N04					84.0			1.60						
	16 x 10	1	MSM031C	1 800	3.2	0.77	0.48	48.8	0.033	2.533	0.80						
			MS2N03B					44.7			0.75						
			MS2N04					248.9			1.70						
		1.5	MSM031C	1 800	2.1		0.37	16.0	0.015	1.126	0.75						
			MS2N03B					16.3			0.75						
			MS2N04					84.5			1.60						
	16 x 16	1	MSM031C	1 100	3.2	1.23	0.55	52.1	0.040	6.485	0.80						
			MS2N03B					48.0			0.75						
			MS2N04					252.2			1.70						
		1.5	MSM031C	1 100	2.1		0.42	17.4	0.018	2.882	0.75						
			MS2N03B					17.7			0.75						
			MS2N04					86.0			1.60						
50	20 x 5	1	MSM031C	6 200	5.5	0.32		256.4	0.085	0.633	1.70	39.8					
			MSM041B					257.1			1.70						
			MS2N04					256.4			1.80						
		1.5	MS2N05	6 300	5.6		0.95	1,161.1	0.085	0.633	4.05						
			MSM031C				6 200	3.7			0.32		0.73	89.0	0.038	0.281	1.60
			MSM041B											91.1			1.60
	MS2N04		89.0	1.55													
	20 x 10	1	MSM031C	4 300	7.7	0.63		259.7	0.088	2.533	1.70						
			MSM041B					260.3			1.70						
			MS2N04					259.7			1.80						
		1.5	MS2N05	4 400	7.9		1.00	1,164.4	0.039	1.126	4.05						
			MSM031C				4 300	5.1			0.77		90.4	0.039	1.126	1.60	
			MSM041B													92.6	1.60
	MS2N04		90.4	1.55													
	20 x 20	1	MSM031C	2 300	8.2	1.27		267.9	0.095	10.132	1.70						
			MSM041B					268.5			1.70						
			MS2N04					267.9			1.80						
		1.5	MS2N05	2 400	8.5		1.10	1,172.5	0.042	4.503	4.05						
MSM031C			2 300				5.5	0.83			94.1	0.042	4.503	1.60			
MSM041B														96.2	1.60		
MS2N04		94.1		1.55													

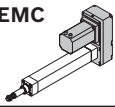
EMC 	d ₀ x P (mm)	i ¹⁾	for motor	Belt side drive									
				F _{max} ³⁾ (N)	M _p ³⁾ (Nm)	v _{max} ³⁾ (m/s)	M _{RS} (Nm)	k _{J fix} ²⁾	k _{J var} ²⁾	k _{J m} ²⁾	m _{sd} (kg)	a _{max} (m/s ²)	
63	25 x 5	1	MSM041B	15 900	14.1	0.28	1.20	1,081.2	0.223	0.633	4.2	28.9	
			MS2N04					1,082.9			4.6		
			MS2N05					1,350.2			4.5		
			MS2N06					1,359.7			4.7		
		2	MSM041B	15 900	7.0		0.83	202.2	3.9				
			MS2N04				188.2	4.2					
	25 x 10	1	MSM041B	10 400	18.5	0.55	1.25	1,089.7	0.243	2.533	4.2	50.0	
			MS2N04					1,091.5			4.6		
			MS2N05					1,358.7			4.5		
			MS2N06					1,368.2			4.7		
		2	MSM041B	10 400	9.3		0.85	204.3	0.061	0.633	3.9		
			MS2N04					190.4			4.2		
	25 x 25	1	MSM041B	4 200	18.6	1.38	1.45	1,117.5	0.242	15.831	4.2	50.0	
			MS2N04					1,119.2			4.6		
			MS2N05					1,386.5			4.5		
			MS2N06					1,396.0			4.7		
		2	MSM041B	4200	9.3		0.95	211.3	0.060	3.958	3.9		
			MS2N04					197.3			4.2		
	80	32 x 5	1	MS2N05	21600	19.1	0.25	1.70	0.607	0.633	4.3	17.9	
				MS2N06				1.75			5,161.9		10.1
				MS2N07				1.10			261.7		10.4
			2	MS2N05				9.5	1.15	861.3	4.4		
		MS2N06		1.15	861.3	9.2							
		32 x 10	1	MS2N05	13 900	24.6		0.50	1.80	0.647	2.533		4.3
MS2N06	18 400			32.6	1.85	5,188.4	10.1						
MS2N07	18 400			32.6	1.85	5,188.4	10.4						
2	MS2N05		13 900	12.3	1.15	268.3	0.162		0.633	4.4			
	MS2N06	18 400	16.3	1.20	867.9	9.2							
32 x 20	1	MS2N05	6 900	24.6	1.00	1.90	0.665	10.132	4.3	50.0			
		MS2N06	11 500	40.8		1.95			5,214.8		10.1		
		MS2N07	11 500	40.8		1.95			5,214.8		10.4		
	2	MS2N05	6 900	12.3		1.20	274.9	0.166	2.533		4.4		
MS2N06		11 500	20.4	1.25	874.5	9.2							
32 x 32	1	MS2N05	4 300	24.6	1.60	2.10	0.684	25.938	4.3	50.0			
		MS2N06	7 600	43.3		2.15			5,294.4		10.1		
		MS2N07				2.15			5,294.4		10.4		
	2	MS2N05	4 300	12.3		1.30	294.8	0.171	6.485		4.4		
MS2N06		7 600	21.7	1.35	894.4	9.2							

¹⁾ Gear ratio of the belt side drive.

²⁾ Constants for calculating the mass moment of inertia. For formulas, see chapter "Drive dimensioning"

³⁾ Force or torque and speed can be limited by the motor

Please pay attention to the note at the end of the table

Drive data

Drive data for motor attachment via belt side drive

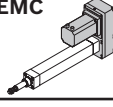
EMC 	d ₀ x P (mm)	i ¹⁾	for motor	Belt side drive								
				F _{max} ³⁾ (N)	M _p ³⁾ (Nm)	v _{max} ³⁾ (m/s)	M _{Rs} (Nm)	k _{J fix} ²⁾	k _{J var} ²⁾	k _{J m} ²⁾	m _{sd} (kg)	a _{max} (m/s ²)
100	40 x 5	1	MS2N06	29 000	25.6	0.18	2.95	5,466.6	1.568	0.633	10.2	12.2
			MS2N07				3.00	7,933.1			11.7	
		2	MS2N06		12.8		1.75	937.5	0.392	0.158	9.3	
			MS2N07				1.80	1,331.6			10.4	
	40 x 10	1	MS2N06	29 000	51.3	0.37	3.05	5,482.2	1.369	2.533	10.2	16.8
			MS2N07				3.10	7,948.7			11.7	
		2	MS2N06		25.6		1.80	941.4	0.342	0.633	9.3	
			MS2N07				1.85	1,335.5			10.4	
	40 x 20	1	MS2N06	19 200	68.1	0.73	3.15	5,539.9	1.408	10.132	10.2	33.0
			MS2N07	29 000	102.6		3.20	8,006.4			11.7	
		2	MS2N06	19 200	34.1		1.85	955.8	0.352	2.533	9.3	
			MS2N07	29 000	51.3		1.90	1,349.9			10.4	
	40 x 40	1	MS2N06	9 600	68.1	1.47	3.05	5,819.0	1.567	40.528	10.2	50.0
			MS2N07	15 000	106.4		3.10	8,285.5			11.7	
		2	MS2N06	9 600	34.1		1.80	1,025.6	0.392	10.132	9.3	
			MS2N07	15 000	53.2		1.85	1,419.7			10.4	
100XC	50 x 10	1	MS2N07	56 000	99.0	0.50	4.60	11,127.9	3.588	2.533	16.9	12.1
			MS2N10				10,690.7	17.7				
		1.5	MS2N07		66.0		3.27	3,897.4	1.595	1.126	16.0	
			MS2N10				3,626.9	16.9				
	50 x 20	1	MS2N07	37 400	132.4	1.00	5.60	11,232.0	3.519	10.132	16.9	22.0
			MS2N10				10,794.8	17.7				
		1.5	MS2N07		88.3		3.93	3,943.7	1.564	4.503	16.0	
			MS2N10				3,673.1	16.9				

¹⁾ Gear ratio of the belt side drive.

²⁾ Constants for calculating the mass moment of inertia. For formulas, see chapter "Drive dimensioning"

³⁾ Force or torque and speed can be limited by the motor

Mechanical efficiency $\eta = 0.9$ (for all sizes)

Note:

All data is given for the complete mechanical drive chain (EMC with belt side drive) at the motor shaft reference point.

F_{max} and v_{max} depend on the selected travel range (s_{max}) of the EMC. See the following tables.

Actual results depend on the selected motor-controller combination.

The motor torque might need to be limited.

For short product names, see chapter "Abbreviations".

Axial load on the cylinder mechanics

Note on special installation and usage example



Installation case III

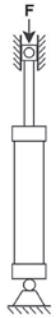

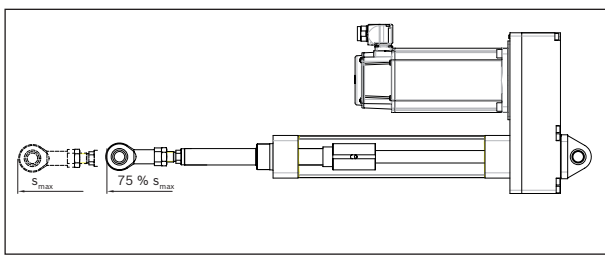

Note: In this installation case the cylinder mechanism of the EMC is loaded by its dead weight in a horizontal position. Thus, the piston rod may be extended horizontally only up to 75% of s_{max} .

Application example:
 Installation case III: Swivel clevis mount on the belt side drive, piston rod guided by means of rod end bearing or fork clevis.

Example for determining the permissible axial load on the cylinder mechanics

Pre-selection for the above installation case III as an application example:

- EMC-063 with Rexroth ball screw assembly 25 x 10
- selected travel range s_{max} 500 mm
- with belt side drive $i=1$ for MS2N05
- fastening with clevis mount and swivel mount

Max. permissible axial load according for installation case in the diagram: approx. 4,200 N.

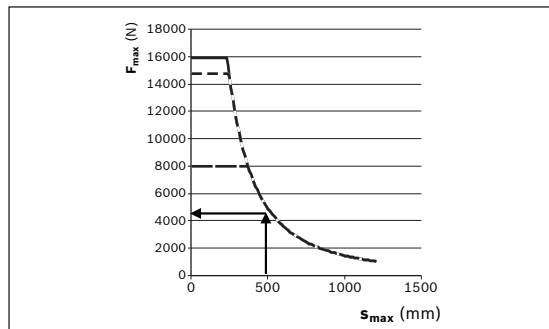

F_{max} in table "Drive data" with motor attachment via belt side drive:
 $F_{max} = 11,400$ N

EMC	$d_0 \times P$ (mm)	i ⁽¹⁾	für Motor		Riemenvorgelege	
			$F_{max}^{(2)}$ (N)	$M_2^{(3)}$ (Nm)		
63	25 x 5	1	MSM041B	15 900	14,1	
			MS2N04			
			MS2N05			
		2	MSM041B	15 900	7,0	
			MS2N04			
			MS2N05			
1	25 x 10	MSM041B	10 400	18,5		
		MS2N04				
		MS2N05				
2	25 x 10	MSM041B	11 400	20,2		
		MS2N04				
		MS2N05				
2	25 x 10	MSM041B	10 400	9,3		
		MS2N04				
		MS2N05				

Note: Limitations caused by additional orderable fastening elements are not taken into account in the consideration of the drive chain.

The F_{max} for the size 63 clevis mount, for example, is 10,900 N.

For F_{max} the smallest value is 4,200 N.

Gabelbefestigung
 Bolzen und Befestigungsschrauben im Lieferumfang enthalten

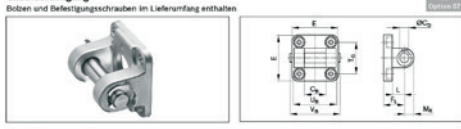

EMC	Materialnummer	Maße (mm)	F_{max}
	C_0	#C ₀	(N)
32	830940700 ¹⁾	20 10 49	22 12 30 32,5 45 50,0 0,09
40	830940800 ¹⁾	28 12 53	25 15 13 38,0 52 57,0 0,11
50	830940900 ¹⁾	32 12 63	27 15 13 46,5 60 65,0 0,18
63	830941000 ¹⁾	40 16 73	32 18 17 56,5 70 76,0 0,25
80	830941200 ¹⁾	50 16 98	36 20 17 72,0 90 96,0 0,32
100	830941400 ¹⁾	60 20 115	43 25 18 89,0 110 117,0 0,70
160MC	831417000 ¹⁾	90 30 177	55 35 25 140,0 170 180,5 2,14

¹⁾ Material Aluminium
²⁾ Material: Stahlnieten und Kugelnutgriffe, verzinkt

Axial load on the cylinder mechanics

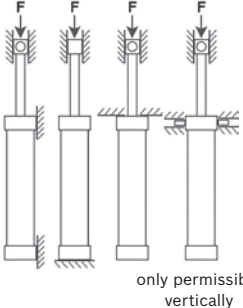
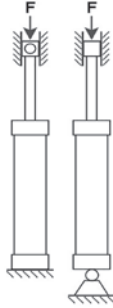
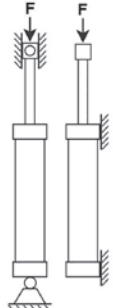
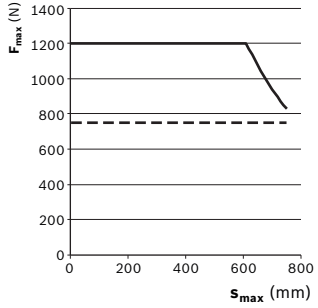
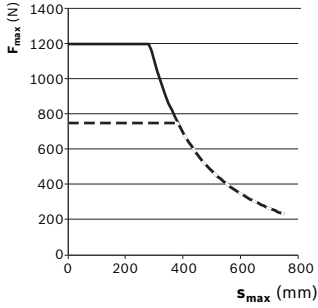
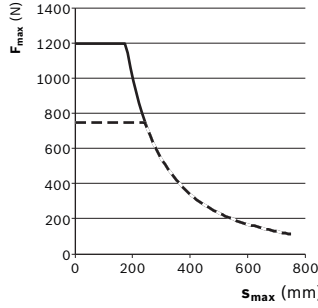
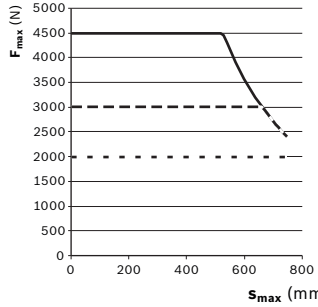
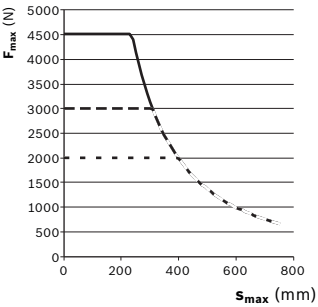
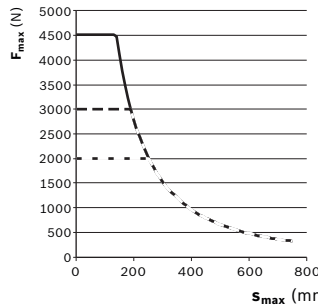
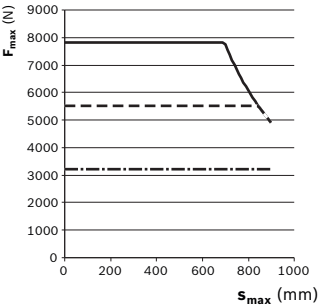
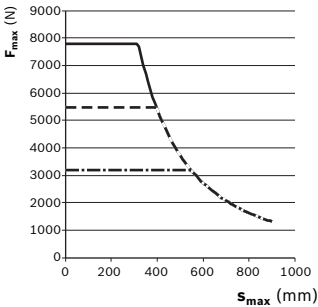
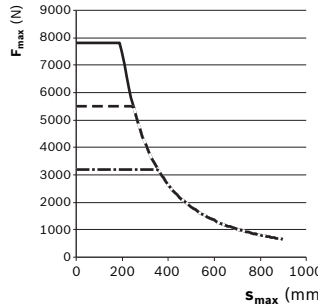
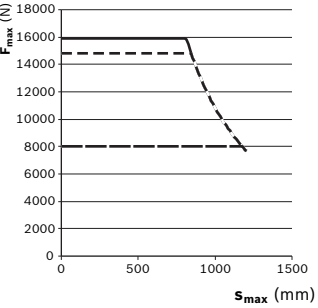
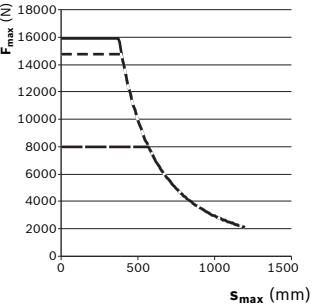
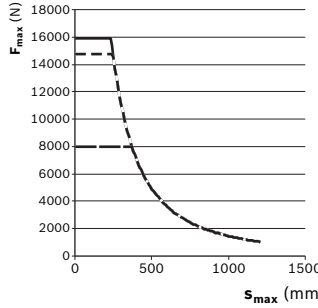
	Case I	Case II	Case III
	 <p>only permissible vertically</p>		
EMC-32	 <p>$d_0 \times P$ — 12 x 5 - - - 12 x 10</p>		
EMC-40	 <p>$d_0 \times P$ — 16 x 5 - - - 16 x 10 . . . 16 x 16</p>		
EMC-50	 <p>$d_0 \times P$ — 20 x 5 - - - 20 x 10 . . . 20 x 20</p>		
EMC-63	 <p>$d_0 \times P$ — 25 x 5 - - - 25 x 10 . . . 25 x 25</p>		

	Case I	Case II	Case III
	<p>only permissible vertically</p>		
EMC-80	<p>$d_0 \times P$ — 32 x 5 - - - 32 x 10 - · - · 32 x 20 - - - 32 x 32</p>		
EMC-100	<p>$d_0 \times P$ — 40 x 5/40 x 10 - · - · 40 x 20/40 x 40</p>		
EMC-100XC	<p>$d_0 \times P$ - - - 50 x 10 - · - · 50 x 20</p>		

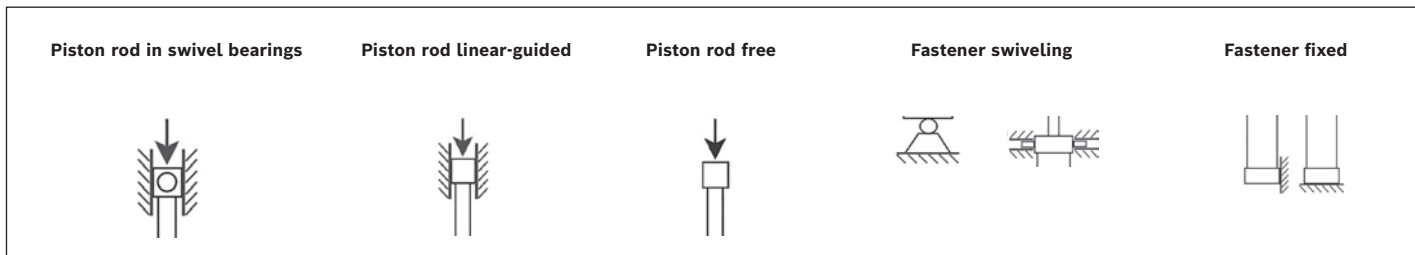

Service life

EMC-32

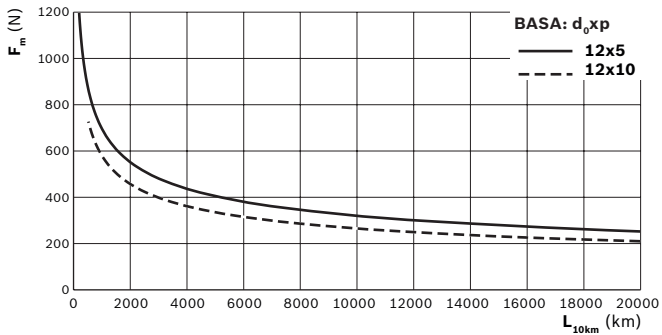

EMC-40

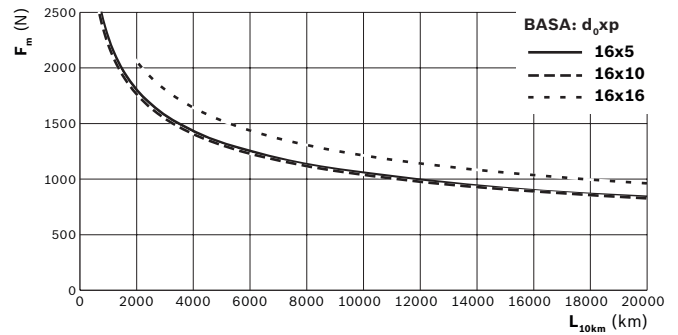

EMC-50

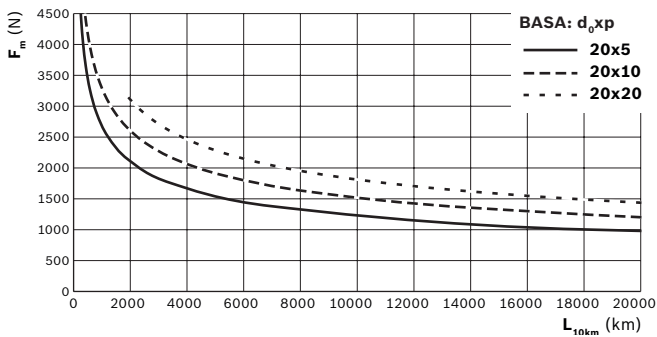

EMC-63

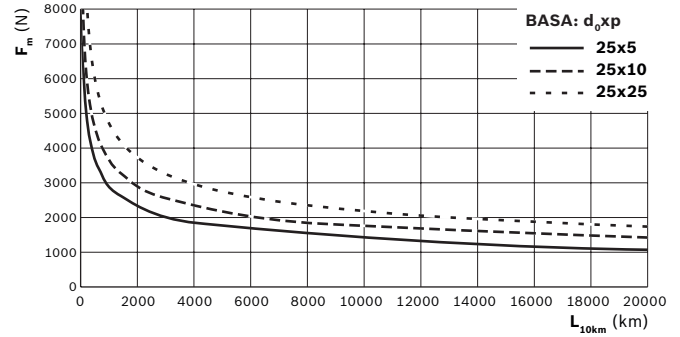

EMC-80

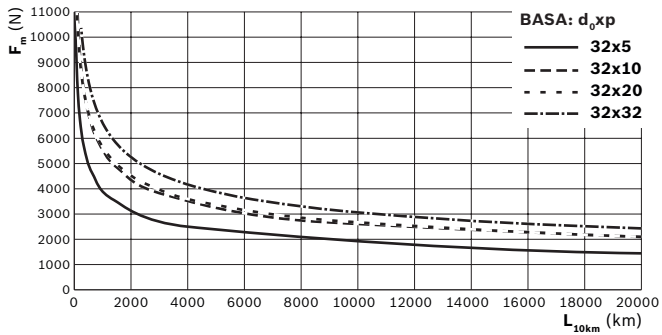

EMC-100

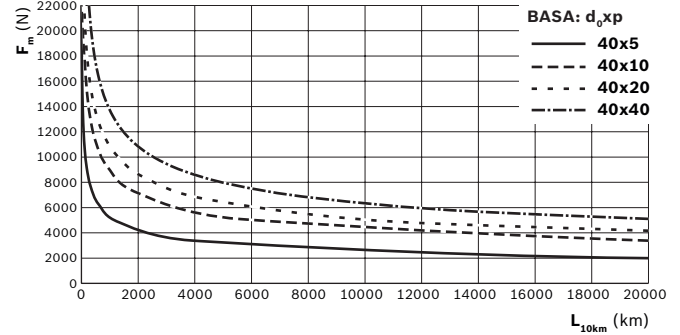

EMC-100XC

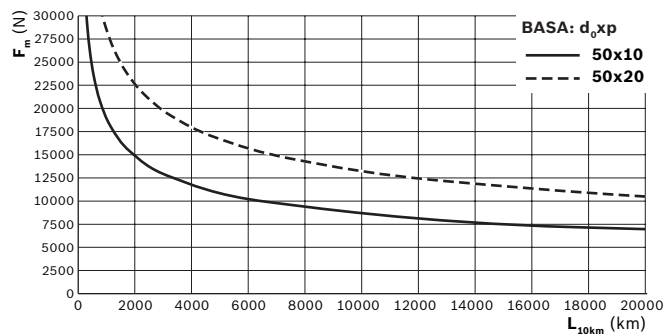

The stated values comply with the specified relubrication intervals (see chapter "Service and information"). For calculation of the equivalent dynamic axial load F_m see chapter "Calculation principles".

F_m = Equivalent dynamic axial load (N)
 $L_{10 km}$ = Nominal service life (km)

Permissible speeds

EMC-32

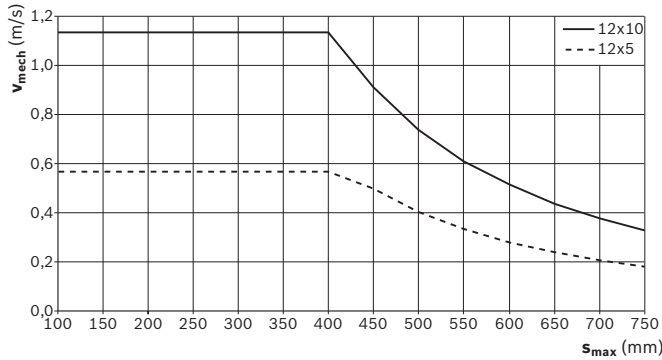

EMC-40

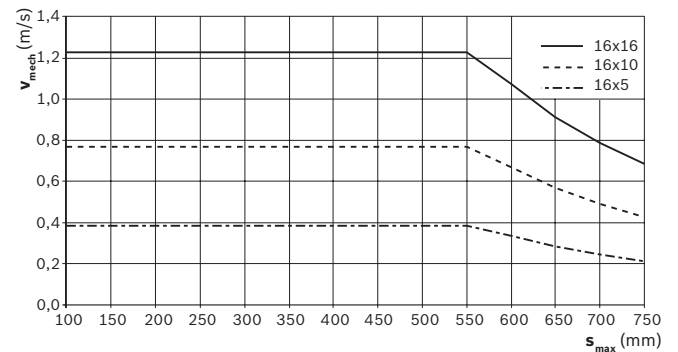

EMC-50

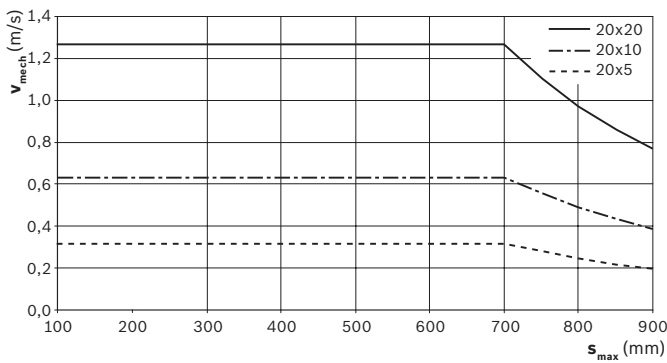

EMC-63

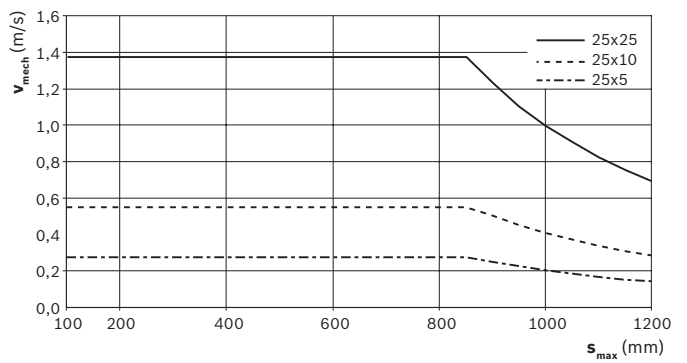

EMC-80

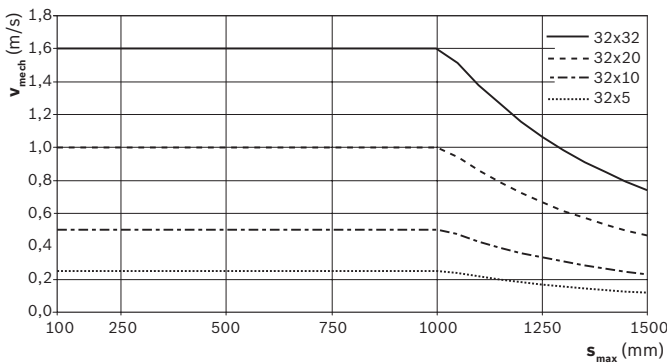

EMC-100

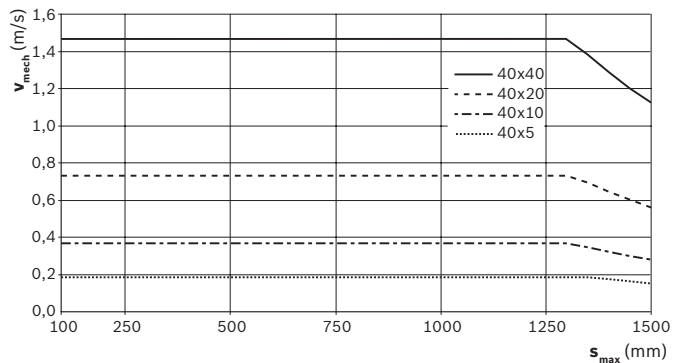

EMC-100XC

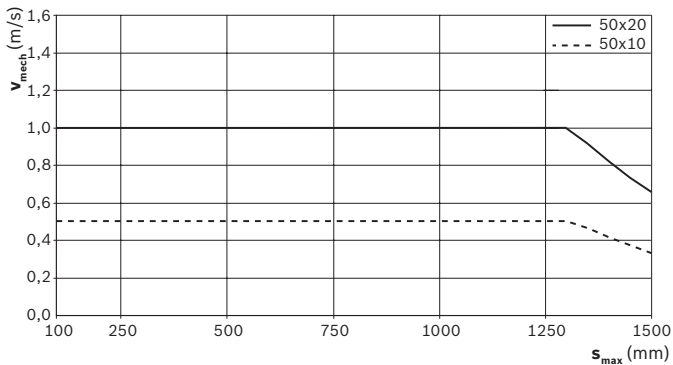

Load on the piston rod

Horizontal mounting

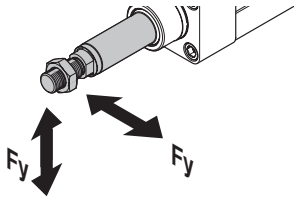

Vertical mounting

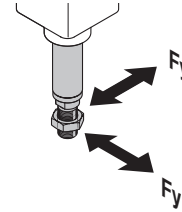

EMC-32

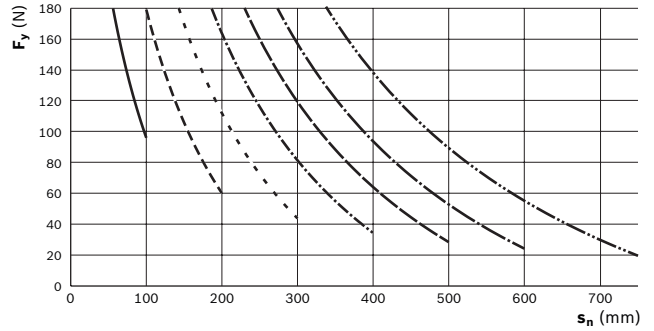
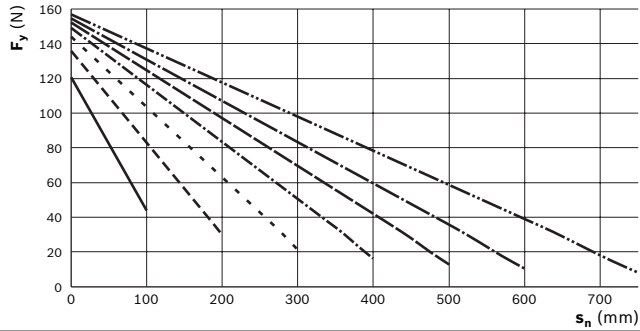

EMC-40

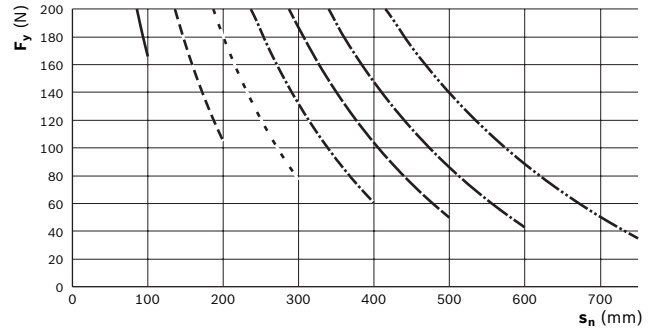
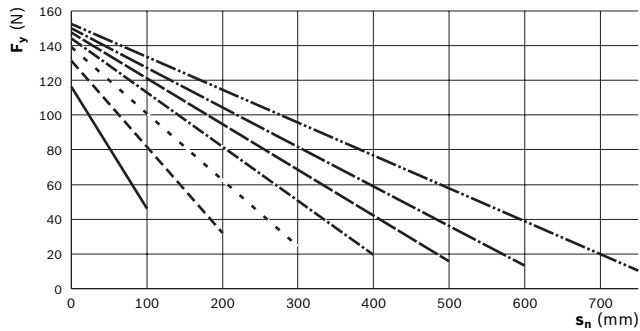

EMC-50

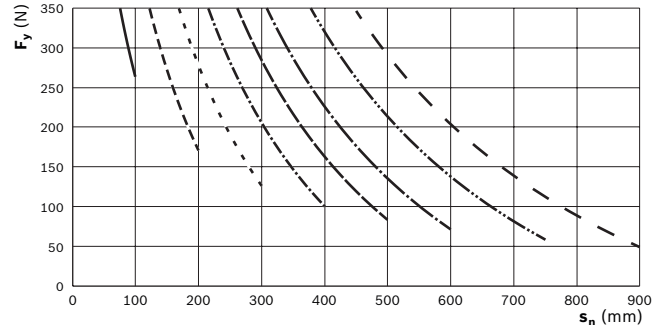
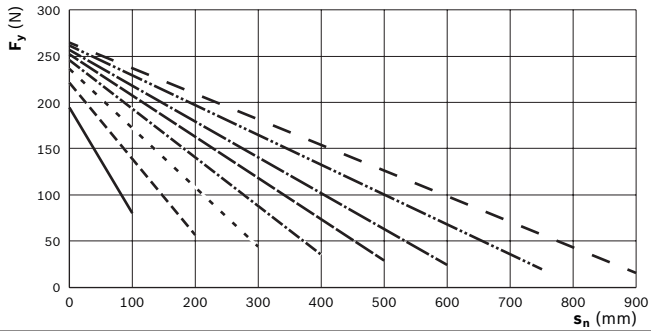

EMC-63

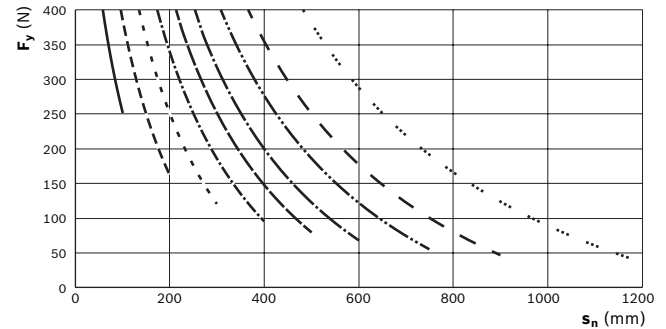
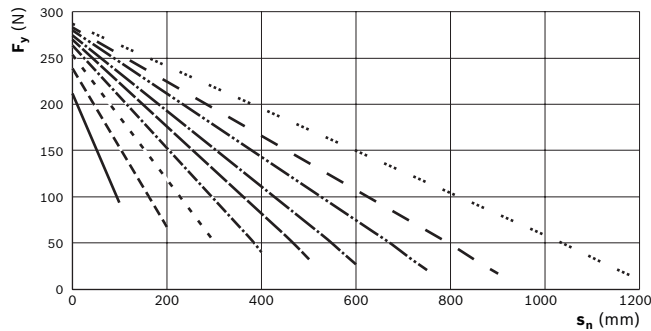

Horizontal mounting

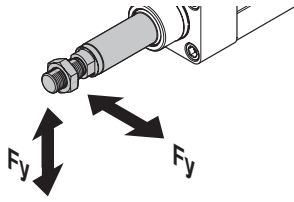

Vertical mounting

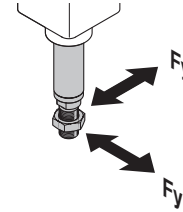

EMC-80

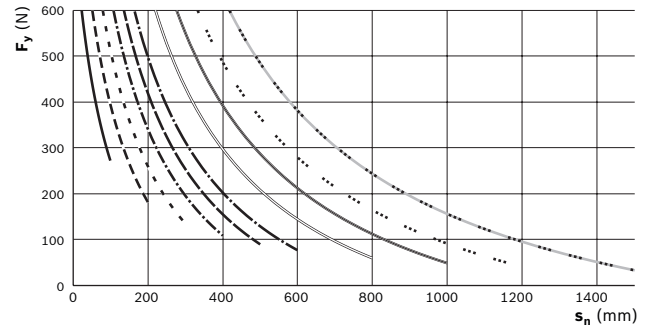
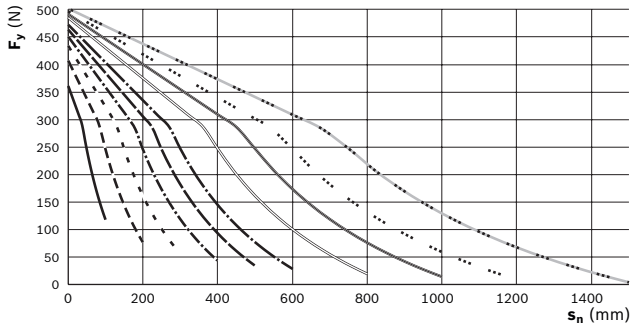

EMC-100

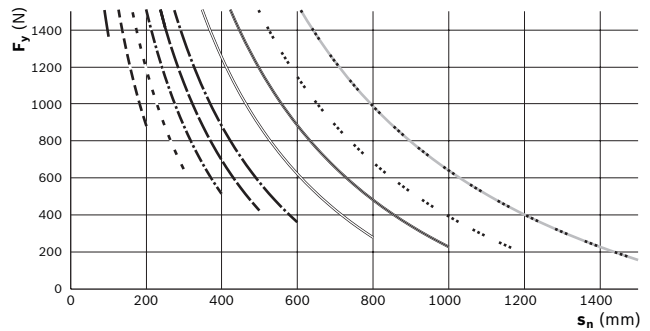
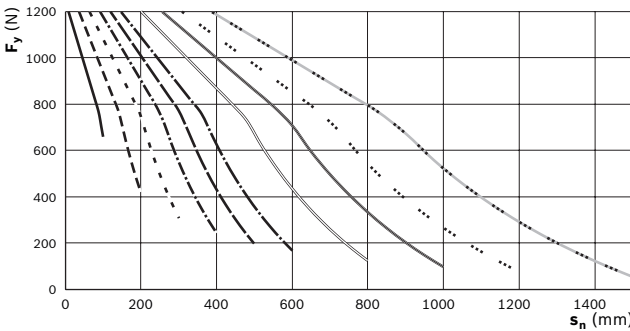

EMC-100XC

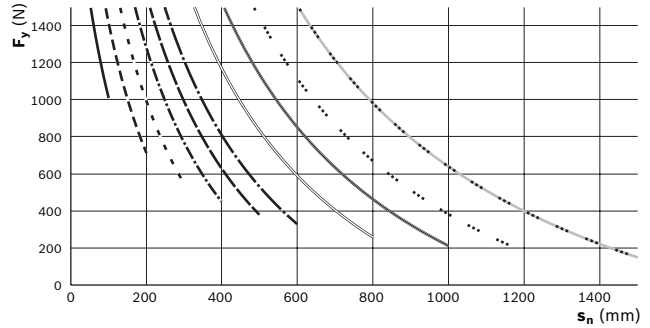
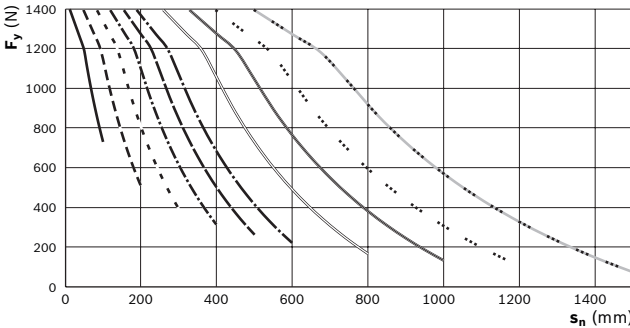

Characteristic curves for s_{max}

—————	100 mm	- - - - -	750 mm
- - - - -	200 mm	—————	800 mm
-	300 mm	- - - - -	900 mm
- - - - -	400 mm	—————	1000 mm
- - - - -	500 mm	· · · · ·	1200 mm
- - - - -	600 mm	- - - - -	1500 mm

F_y = Lateral force (N)
 s_n = Position of the piston rod (mm)
 s_{max} = Maximum travel range (mm)
 L_{ZS} = Position of the piston rod retracted (mm)

Diagrams are valid for:

- 25% of F_{max}
- a speed of 0.5 m/s

Definition s_{max} / s_n

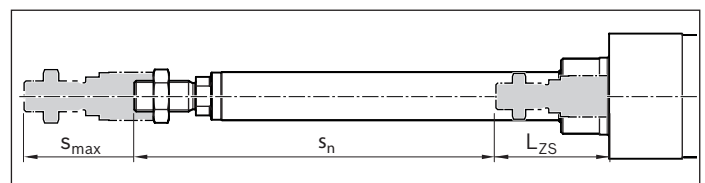

Calculation principles

Drive chain

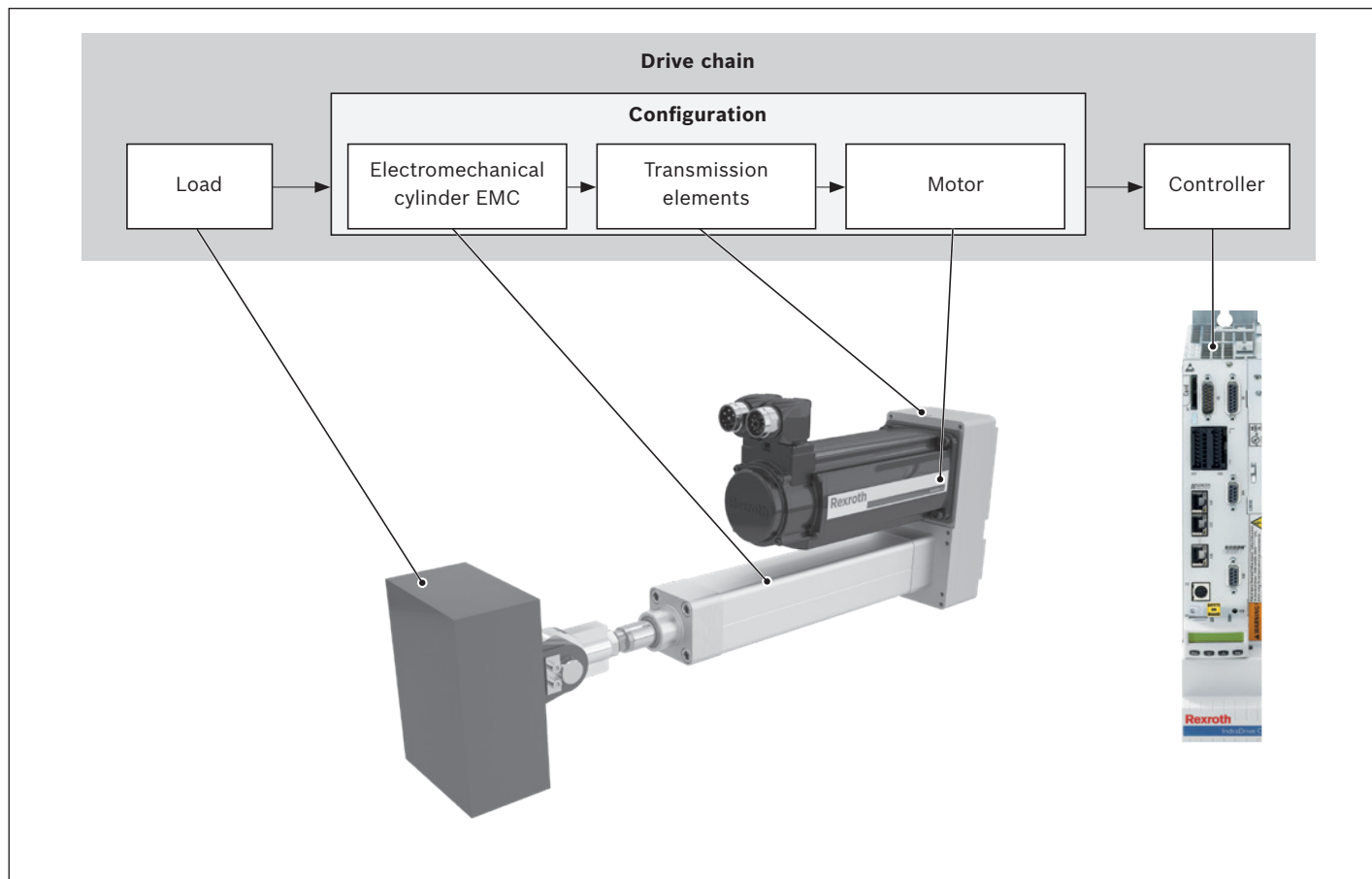

The correct dimensioning and assessment of an application requires structured consideration of the entire drive chain. The basic element of the drive chain is the configuration – comprising the electromechanical cylinder EMC, the transmission element (coupling or belt side drive) and the motor, which can be ordered in this constellation as per the catalog.

Maximum permissible loads

When selecting electromechanical cylinders EMC, maximum limits for permissible loads and forces must be taken into account. These limits can be found in chapter "Product description and technical data".

The values in this chapter are system-based, i.e. the limits are based not only on the load rating of the bearings, but also on design/material limits.

Mechanical calculation

Service life of electromechanical cylinder EMC

Where the operating conditions vary (fluctuating linear speed and load), the service life must be calculated using the average values for F_m and v_m .

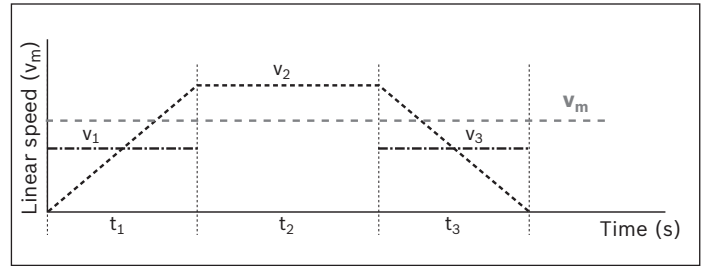

When the linear speed varies, the average speed v_m is calculated as follows:

$$v_m = \frac{1}{t_{ges}} \cdot (|v_1| \cdot t_1 + |v_2| \cdot t_2 + \dots + |v_n| \cdot t_n)$$

$$t_{ges} = t_1 + t_2 + \dots + t_n$$

When both the load and the rotary speed vary, the average load F_m is calculated as follows:

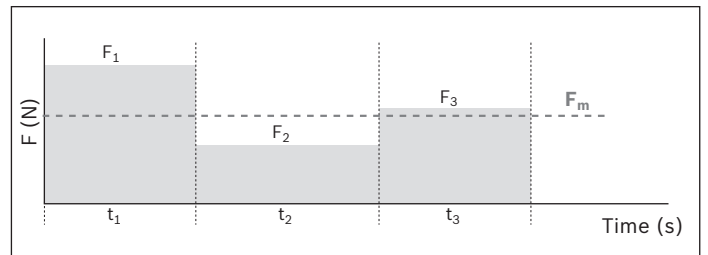

$$F_m = \sqrt[3]{|F_1|^3 \cdot \frac{|v_1|}{v_m} \cdot \frac{t_1}{t_{ges}} + |F_2|^3 \cdot \frac{|v_2|}{v_m} \cdot \frac{t_2}{t_{ges}} + \dots + |F_n|^3 \cdot \frac{|v_n|}{v_m} \cdot \frac{t_n}{t_{ges}}}$$

Nominal service life

- in revolutions L

$$L = \left(\frac{C}{F_m} \right)^3 \cdot 10^6$$

- in hours L_h

$$L_h = \frac{L}{n_m \cdot 60}$$

Drive torque M:

$$M = \frac{F \cdot P}{2,000 \cdot \pi \cdot \eta}$$

Drive dimensioning

Basic principles

For drive dimensioning, the drive chain can be divided into the **mechanical system** and **drive system**.

The **mechanical system** includes the physical components – electromechanical cylinder EMC (including gear unit transmission element) – and the load to be carried.

The electric **drive** is a motor-controller combination with corresponding performance data.

The dimensioning of the electric drive is done taking the motor shaft as a reference point.

For drive dimensioning, limits must be taken into account as well as base values. The limits must not be exceeded in order to avoid damaging the mechanical components.

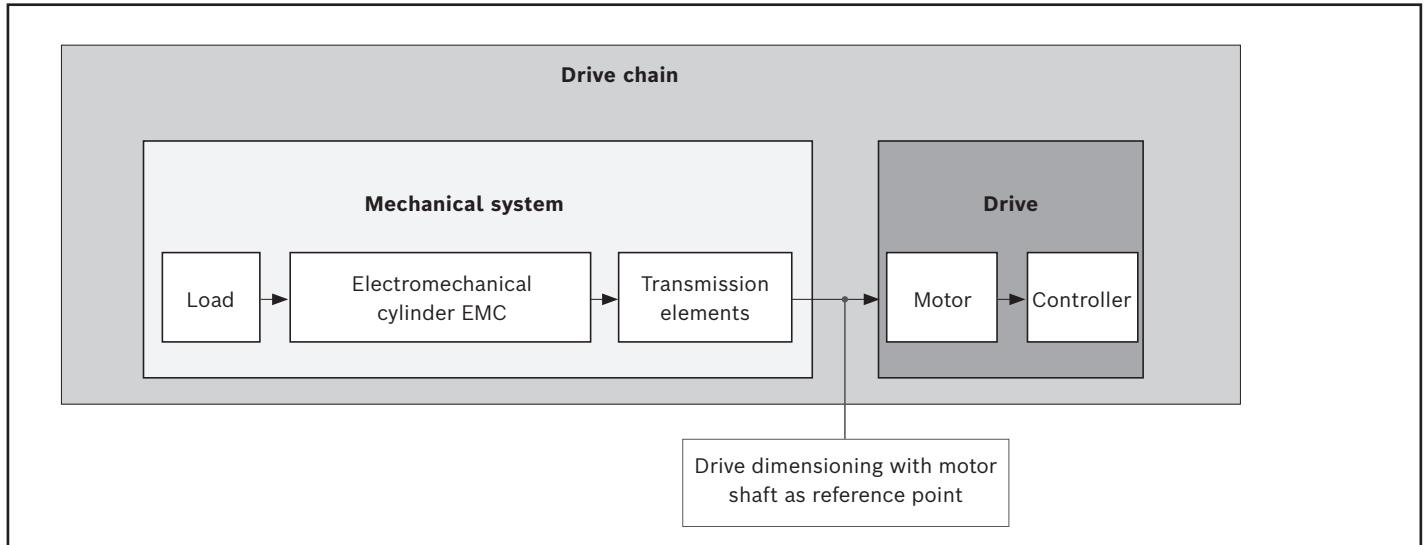

Technical data and formula symbols for the mechanical system

The relevant data for flange / coupling or belt side drive is already included in the specifications for the electromechanical cylinder EMC. In other words, the corresponding maximum permissible limits for drive torque and speed, as well as the underlying friction torque and mass moment of inertia with respect to the motor shaft are reduced, and can be taken directly from the tables (see "Drive data").

The following technical data with the associated symbols are used when considering the basic mechanical system requirements in the design calculations for drive dimensioning. The data listed in the table below can be found in chapter "Technical Data" or is determined using formulas based on the descriptions on the following pages.

		Mechanical system	
		Load	EMC
Weight moment	(Nm)	$M_g^{4)}$	—
Equivalent dynamic torque	(Nm)	$M_m^{1)}$	—
Friction torque	(Nm)	—	$M_{RS}^{3)}$
Mass moment of inertia	(kgm ²)	$J_t^{1)}$	$J_s^{2)}$
Max. permissible travel speed	(m/s)	—	$v_{max}^{3)}$
Max. permissible rotary speed	(min ⁻¹)		$n_p^{3)}$
Max. permissible drive torque	(Nm)	—	$M_p^{3)}, M_{pl}^{1)}$

1) Determine the value using the appropriate formula

2) Length-dependent value, determined using the appropriate formula

3) Use the value from the table

4) For vertical installation position: Determine the value using the appropriate formula

Drive dimensioning with motor shaft as reference point

When dimensioning the drive, all relevant design calculation values for the mechanical components in the drive chain have to be determined and be expressed/reduced to the motor shaft. In other words, for a combination of mechanical components within the drive chain, this will result in one value for each of the following:

- Friction torque M_R
- Mass moment of inertia J_{ex}
- Max. permissible speed v_{mech}
(maximum permissible rotary speed n_{mech})
- Max. permissible drive torque M_{mech}

Determination of the values for each mechanical component in the drive chain based on the motor shaft as a reference point

Friction torque M_R

With the value for friction torque of the EMC, friction is already reduced to the motor shaft.

$$M_R = M_{Rs}$$

Mass moment of inertia J_{ex}

The constants $k_{J_{fix}}$, $k_{J_{var}}$ and k_{J_m} used in the formulas already contain the mass moment of inertia and gear ratios for any incorporated transmission elements, and can therefore be taken from the "Drive data" table.

$$J_{ex} = J_s + J_t$$

Determining the mass moment of inertia of the EMC component (including transmission elements, if used)

$$J_s = (k_{J_{fix}} + k_{J_{var}} \cdot s_{max}) \cdot 10^{-6}$$

Determination of the translative mass moment of inertia of the external load (reduced to motor shaft)

$$J_t = m_{ex} \cdot k_{J_m} \cdot 10^{-6}$$

Maximum permissible speed and maximum permissible rotary speed

The value for the maximum permissible speed of the EMC already includes the permissible rotary speed for any incorporated transmission elements.

Maximum permissible speed v_{mech}

$$v_{mech} = v_{max}$$

Maximum permissible rotary speed n_{mech}

$$n_{mech} = n_p$$

When considering the complete drive chain (mechanical system + motor/controller) the rotary speed of the motor can lie below the maximum value for the mechanical system (M_{mech}) and thus limit the maximum permissible rotary speed of the overall drive chain.

Drive dimensioning

Maximum permissible drive torque M_p , M_{mech}

The lower value of the permissible drive torque of all mechanical components contained in the drive chain (M_p) and allowable axial load from the user-defined installation case determines the maximum permissible drive torque of the mechanical system which needs to be taken into account as a limitation in the drive dimensioning.

The smaller value from the drive data table or that calculated from the F_{max} value from the permissible axial load on the cylinder mechanism diagram is valid.

$$M_{pl} = \frac{F_{max} \cdot P}{2,000 \cdot \pi \cdot \eta}$$

$$M_{mech} = \text{Minimum} (M_p; M_{pl})$$

When considering the complete drive chain (mechanical system + motor/controller) the maximum torque of the motor can lie below the maximum value for the mechanical system (M_{mech}) and thus limit the maximum permissible drive torque of the overall drive chain.

If the maximum torque of the motor lies above the upper limit for the mechanical system (M_{mech}), the maximum motor torque must be limited to the permissible value for the mechanical system.

Pre-selecting the motor

The motor can be generally preselected using the following conditions.

Condition 1:

The rotary speed of the motor must be greater than or equal to the rotary speed required for the mechanical system (but not exceeding the maximum permissible limit value).

$$n_{max} \geq n_{mech}$$

Condition 2:

Consideration of the ratio of mass moments of inertia of the mechanical system and the motor. The ratio of the mass moments of inertia serves as an indicator for the control performance of a motor-controller combination.

The mass moment of inertia of the motor is directly related to the motor size.

Mass moment of inertia ratio

$$v = \frac{J_{ex}}{J_m + J_{br}}$$

For preselection, experience has shown that the following ratios will result in high control performance.

These are not rigid limits, but values exceeding them will require closer consideration of the specific application.

Application area	v
Handling	≤ 6.0
Machining	≤ 1.5

Condition 3:

Estimation of the ratio of the static load moment to the continuous torque of the motor. The torque ratio must be less than or equal to an empirical value of 0.6. This condition roughly factors in the missing dynamic characteristics of an exact motion profile with the required motor torques.

Torque ratio:

$$\frac{M_{\text{stat}}}{M_0} \leq 0.6$$

Static load moment:

$$M_{\text{stat}} = M_R + M_g + M_m$$

Weight moment:

For vertical installation position only!

For motor attachment via flange and coupling: $i = 1$

$$M_g = \frac{P \cdot (m_{\text{ex}} + m_{\text{ca}}) \cdot g}{2\,000 \cdot \pi \cdot i \cdot \eta}$$

Equivalent dynamic torque:

$$M_m = \frac{F_m \cdot P}{2\,000 \cdot \pi \cdot i \cdot \eta}$$

The equivalent dynamic torque can be calculated approximately via the average load F_m .

The appropriate mechanical efficiency must be used depending on the drive element BASA.

In chapter "Configuration and ordering", users can put together standard configurations including gear reducer and motor, for the various EMC sizes by selecting the appropriate options. By checking the three conditions stated above, it is possible to see whether a standard motor selected in a particular configuration will generally be of a suitable size for the specific application.

Precise drive dimensioning

Preselecting the motor according to this rough guide is no substitute for the required precise design calculations for the drive, taking all moments/torques and rotary speed levels into account. For precise calculation of the electric drive, including consideration of the specific motion profile, please refer to the performance data in the catalog "Rexroth drive technology". When dimensioning the drive, the maximum permissible values for speed, drive torque and acceleration must not be exceeded, in order to avoid damaging the mechanical system!

EMC 32 – EMC 50

Size short product name	Max. travel range mm	Housing			Drive		Lubrication ¹⁾					Switch ⁶⁾		Version			
		Standard	IP65 enclosure protection class	IP65 enclosure protection class +R	BASA d ₀ x P (mm)		LSS	LCF	LPG	LHG	LFL ⁹⁾	without switch and sensor profile	Sensor profile	Switches 1, 2, 3, 4			
EMC-032-NN-2					12 x 5	01								PNP NC contact	120	OF01	without motor attachment
					12 x 10	02									MF01	with flange	
															RV01 RV02 RV03	with belt side drive	
EMC-040-NN-2		01	02	03	16 x 5	01	01	02	03	04	05	00	80	NPN NC contact	121	OF01	without motor attachment
					16 x 10	02									MF01	with flange	
					16 x 16	03									RV01 RV02 RV03	with belt side drive	
EMC-050-NN-2					20 x 5	01								PNP NO contact	122	OF01	without motor attachment
					20 x 10	02									MF01	with flange	
					20 x 20	04									RV01 RV02 RV03	with belt side drive	

- ¹⁾ LSS: Standard lubrication; LCF: prepared for central lubrication system for fluid grease; LPG: preserved version; LHG: initial lubrication with NSF-H1 grease; LFL: lifelong lubrication.
- ²⁾ Attachment kit also available without motor (when ordering: enter "00" for motor); for motor attachment kit for customer motor see chapter "Motor attachment".
- ³⁾ For motor types see chapter "IndraDyn S - servo motors"
- ⁴⁾ Measurement of frictional torque
- ⁵⁾ Lead deviation
- ⁶⁾ Sensor profile and switch not possible in combination with version RV03
- ⁷⁾ Lube connection for LSS, LCF, LPG, LHG; for LFL lubrication: Housing without lube connection
- ⁸⁾ Slot for sensor profile
- ⁹⁾ Application conditions, see page 5

Flange (F)	Motor connector position			
	0°	90°	180°	270°
MF01	000	090 ★	180	270

★ standard delivery

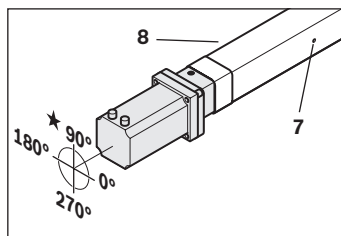

Example:
Flange MF01
Motor connector position 90°

Motor attachment		Motor						Documentation		
Gear ratio	Attachment kit ²⁾	Motor code ³⁾	Cables		Brake		Motor connector position	Standard report	Measurement reports	
			2 cables	1 cable	without	with				
		00	without		00					
		01	MSM019B-0300	134	135	-		000		
		02	MSM031B-0300	136	137	-				
		03	MS2N03-B0BYN	-	-	203	204			
i = 1		41	MSM019B-0300	134	135	-				
		42	MSM031B-0300	136	137	-				
		43	MS2N03-B0BYN	-	-	203	204			
		00	without		00			01	02 ⁴⁾	03 ⁵⁾
		05	MSM031C-0300	138	139	-				
		06	MS2N03-B0BYN	-	-	203	204			
		200	MS2N03-D0BYN	-	-	207	208			
		07	MS2N04-B0BTN	-	-	211	212			
i = 1		45	MSM031C-0300	138	139	-				
		46	MS2N03-B0BYN	-	-	203	204			
		47	MS2N04-B0BTN	-	-	211	212			
i = 1.5		47	MS2N04-C0BTN	-	-	215	216			
		49	MSM031C-0300	138	139	-				
		50	MS2N03-B0BYN	-	-	203	204			
		51	MS2N04-B0BTN	-	-	211	212			
		00	without		00			180		
		09	MSM031C-0300	138	139	-				
		10	MSM041B-0300	140	141	-				
		11	MS2N04-B0BTN	-	-	211	212			
			MS2N04-C0BTN	-	-	215	216			
		12	MS2N05-B0BTN	-	-	223	224			
i = 1		53	MSM031C-0300	138	139	-				
		54	MSM041B-0300	140	141	-				
		55	MS2N04-C0BTN	-	-	215	216			
i = 1.5		56	MS2N05-C0BTN	-	-	227	228			
		58	MSM031C-0300	138	139	-				
		59	MSM041B-0300	140	141	-				
		60	MS2N04-B0BTN	-	-	211	212			

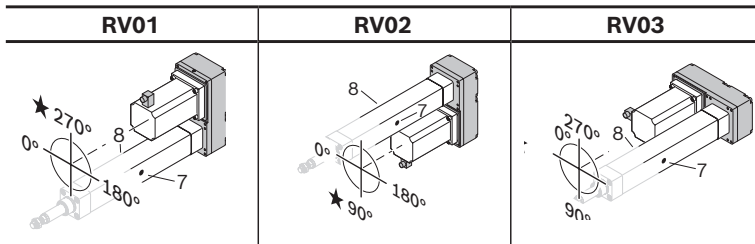

Example:
Belt side drive RV02
Motor connector position 90°

Belt side drive	Motor connector position			
	0°	90°	180°	270°
RV01	000	-	180	270 ★
RV02	000	090 ★	180	-
RV03	000 ★	090	-	270

Explanation of the order parameters and ordering example
⇒ Chapter "Ordering example".

★ standard delivery

EMC 63 – EMC 80

Size short product name	Max. travel range mm	Housing			Drive		Lubrication ¹⁾					Switch ⁶⁾		Version			
		Standard	IP65 enclosure protection class	IP65 enclosure protection class +R	BASA d ₀ x P (mm)		LSS	LCF	LPG	LHG	LFL ⁹⁾	without switch and sensor profile	Sensor profile	Switches 1, 2, 3, 4			
EMC-063-NN-2		01	02	03	25 x 5	01	01	02	03	04	05	00	80	PNP NC contact	120	OF01	without motor attachment
														MF01	with flange		
														NPN NC contact	121	RV01 RV02 RV03	with belt side drive
EMC-080-NN-2		01	02	03	32 x 5	01	01	02	03	04	05	00	80	PNP NO contact	122	OF01	without motor attachment
														MF01	with flange		
														NPN NO contact	123	RV01 RV02 RV03	with belt side drive

- 1) LSS: Standard lubrication; LCF: prepared for central lubrication system for fluid grease; LPG: preserved version; LHG: initial lubrication with NSF-H1 grease; LFL: lifelong lubrication;
- 2) Attachment kit also available without motor (when ordering: enter "00" for motor); for motor attachment kit for customer motor see chapter "Motor attachment".
- 3) For motor types see chapter "IndraDyn S - servo motors"
- 4) Measurement of frictional torque
- 5) Lead deviation
- 6) Sensor profile and switch not possible in combination with version RV03
- 7) Lube connection for LSS, LCF, LPG, LHG; for LFL lubrication: Housing without lube connection
- 8) Slot for sensor profile
- 9) Application conditions must be observed, see page 5

Flange (F)	Motor connector position			
	0°	90°	180°	270°
MF01	000	090 ★	180	270

★ standard delivery

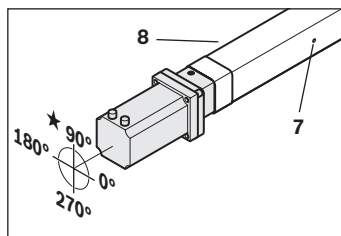

Example:
Flange MF01
Motor connector position 90°

Motor attachment		Motor						Documentation		
Gear ratio	Attachment kit ⁽²⁾	Motor code ⁽³⁾	Cables		Motor connector position		Standard report	Measurement reports		
			2 cables Brake	1 cable Brake						
			without	with	without	with				
	00	without			00					
	14	MSM041B-0300	140	141	-		00			
	15	MS2N04-D0BQN	-	-	219	220				
	16	MS2N05-D0BRN	-	-	231	232				
	17	MS2N06-C0BTN	-	-	239	240				
		MS2N06-D0BRN	-	-	243	244				
	62	MSM041B-0300	140	141	-		090			
	63	MS2N04-D0BQN	-	-	219	220				
	64	MS2N05-D0BRN	-	-	231	232				
		MS2N06-C0BTN	-	-	239	240				
	65	MS2N06-D1BNN	-	-	247	248				
	i = 2	67	MSM041B-0300	140	141	-		01	02 ⁽⁴⁾	03 ⁽⁵⁾
		68	MS2N04-C0BTN	-	-	215	216			
		69	MS2N05-B0BTN	-	-	223	224			
	00	without			00		180			
	19	MS2N05-D0BRN	-	-	231	232				
		MS2N06-C0BTN	-	-	239	240				
	20	MS2N06-D0BRN	-	-	243	244				
		MS2N06-E0BRN	-	-	251	252				
	201	MS2N07-C0BQN	-	-	259	260				
		MS2N07-D0BRN	265	266	-					
	i = 1	71	MS2N05-D0BRN	-	-	231	232	270		
		72	MS2N06-D1BNN	-	-	247	248			
		202	MS2N07-B1BNN	-	-	255	256			
			MS2N07-C1BRN	-	-	263	264			
	i = 2	75	MS2N05-B0BTN	-	-	223	224			
		76	MS2N05-C0BTN	-	-	227	228			
			MS2N06-C0BTN	-	-	239	240			
			-	-	243	244				

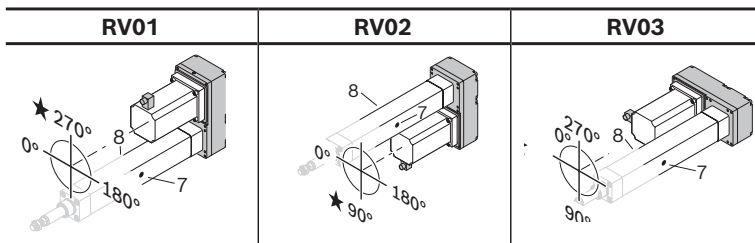

Example:
Belt side drive RV02
Motor connector position 90°

Belt side drive	Motor connector position			
	0°	90°	180°	270°
RV01	000	-	180	270 ★
RV02	000	090 ★	180	-
RV03	000 ★	090	-	270

★ standard delivery

Explanation of the order parameters and ordering example
⇒ Chapter "Ordering example".

EMC 100 – EMC 100XC

Size short product name	Max. travel range mm	Housing			Drive		Lubrication ¹⁾					Switch ⁶⁾			Version		
		Standard	IP65 enclosure protection class	IP65 enclosure protection class +R	BASA d ₀ x P (mm)		LSS	LCF	LPG	LHG	LFL ⁹⁾	without switch and sensor profile	Sensor profile	Switches 1, 2, 3, 4			
EMC-100-NN-2		01	02	03	40 x 5	01	01	02	03	04	05	00	80	PNP NC contact	120	OF01	without motor attachment
					40 x 10	02										MF01	with flange
					40 x 20	04										RV01 RV02 RV03	with belt side drive
					40 x 40	07											
EMC-100-XC-2		01	02	03	50 x 10	02	01	02	03	04	05	00	80	PNP NO contact	122	OF01	without motor attachment
					50 x 10	02										MF01	with flange
					50 x 20	04										RV01 RV02 RV03	with belt side drive

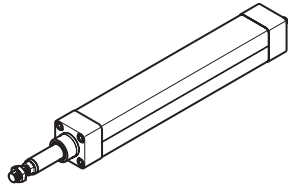

- ¹⁾ LSS: Standard lubrication; LCF: prepared for central lubrication system for fluid grease; LPG: preserved version; LHG: initial lubrication with NSF-H1 grease; LFL: lifelong lubrication;
- ²⁾ Attachment kit also available without motor (when ordering: enter "00" for motor); for motor attachment kit for customer motor see chapter "Motor attachment".
- ³⁾ For motor types see chapter "IndraDyn S - servo motors"
- ⁴⁾ Measurement of frictional torque
- ⁵⁾ Lead deviation
- ⁶⁾ Sensor profile and switch not possible in combination with version RV03
- ⁷⁾ Lube connection for LSS, LCF, LPG, LHG; for LFL lubrication: Housing without lube connection
- ⁸⁾ Slot for sensor profile
- ⁹⁾ Application conditions must be observed, see page 5

Flange (F)	Motor connector position			
	0°	90°	180°	270°
MF01	000	090 ★	180	270

★ standard delivery

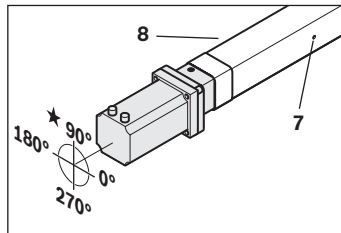

Example:
Flange MF01
Motor connector position 90°

Motor attachment		Motor						Documentation		
Gear ratio	Attachment kit ²⁾	Motor code ³⁾	Cables 2 cables		1 cable		Motor connector position	Standard report	Measurement reports	
			without brake	with brake	without brake	with brake				
	00	without			00					
	23	MS2N06-D0BRN	-	-	243	244	00			
		MS2N06-E0BRN	-	-	251	252				
		MS2N07-C0BQN	-	-	259	260				
	24	MS2N07-D0BRN	265	266	-		090			
		MS2N07-E0BQN	271	272						
	203	MS2N06-D1BNN	-	-	247	248				
	79	MS2N07-C1BRN	-	-	263	264				
		MS2N07-D0BRN	265	266	-					
		MS2N07-E0BQN	271	272						
	204	MS2N06-C0BTN	-	-	239	240	01	02 ⁴⁾	03 ⁵⁾	
		MS2N06-D0BRN	-	-	243	244				
		MS2N06-E0BRN	-	-	251	252				
	205	MS2N07-B1BNN	-	-	255	256				
		MS2N07-C0BQN	-	-	259	260				
		MS2N07-D0BRN	265	266	-					
	00	without			00		180			
	27	MS2N07-E0BQN	271	272	-					
	28	MS2N10-D0BNN	277	278						
		MS2N10-E0BNN	279	280						
	85	MS2N07-E1BNN	273	274	-		270			
	86	MS2N10-D0BNN	277	278						
	88	MS2N07-D1BNN	-	-	269	270				
		MS2N07-E1BNN	273	274	-					
		89	MS2N10-C0BNN	275	276	-				
	MS2N10-D0BNN		277	278						

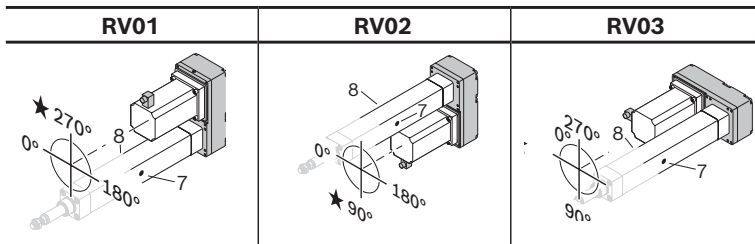

Example:
Belt side drive RV02
Motor connector position 90°

Belt side drive	Motor connector position			
	0°	90°	180°	270°
RV01	000	-	180	270 ★
RV02	000	090 ★	180	-
RV03	000 ★	090	-	270

Explanation of the order parameters
and ordering example

⇒ Chapter "Ordering example".

★ standard delivery

Fastening elements

Fastening element							
Version	Group						
	1		2		3		4
without motor attachment OF01 	00 without	01 	00 without	01 	00 without	01 ¹⁾ 	00 without
with flange and coupling MF01 	02 Clevis mount with force measuring bolt	07 Stainless steel	02 	03 	03 ¹⁾ 	04 	06 EMC-32 - EMC-50
		02 	04 	04 	06 EMC-63 - EMC-100XC 		
with belt side drive RV01 to RV03 		05 	05 	05 			
		06 Stainless steel	06 Stainless steel	06 Stainless steel			

¹⁾ Only permissible vertically

²⁾ Fastening elements are supplied assembled when version with flange and coupling is selected

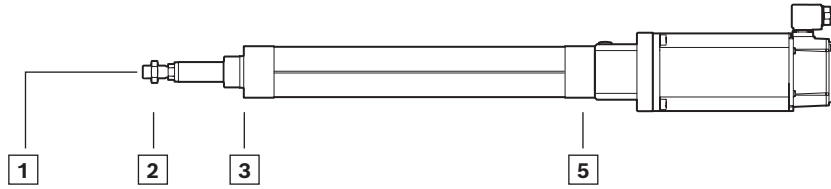

Version	Group			
	5		6	
	00	without	00	without
without motor attachment OF01	01 ²⁾ 			
	03 ²⁾ 			
with flange and coupling MF01	05 ²⁾ EMC-32 - EMC-50 EMC-63 - EMC-100XC 			
	06 EMC-32 - EMC-50 EMC-63 - EMC-100XC 			
	07		01 EMC-32 - EMC-50 EMC-63 - EMC-100XC 	02
with belt side drive RV01 to RV03	08		03 EMC-32 - EMC-50 EMC-63 - EMC-100XC 	04
	10	 Clevis mount with force measuring bolt	05 	

Note: Fastening elements are included

Dimension drawing EMC

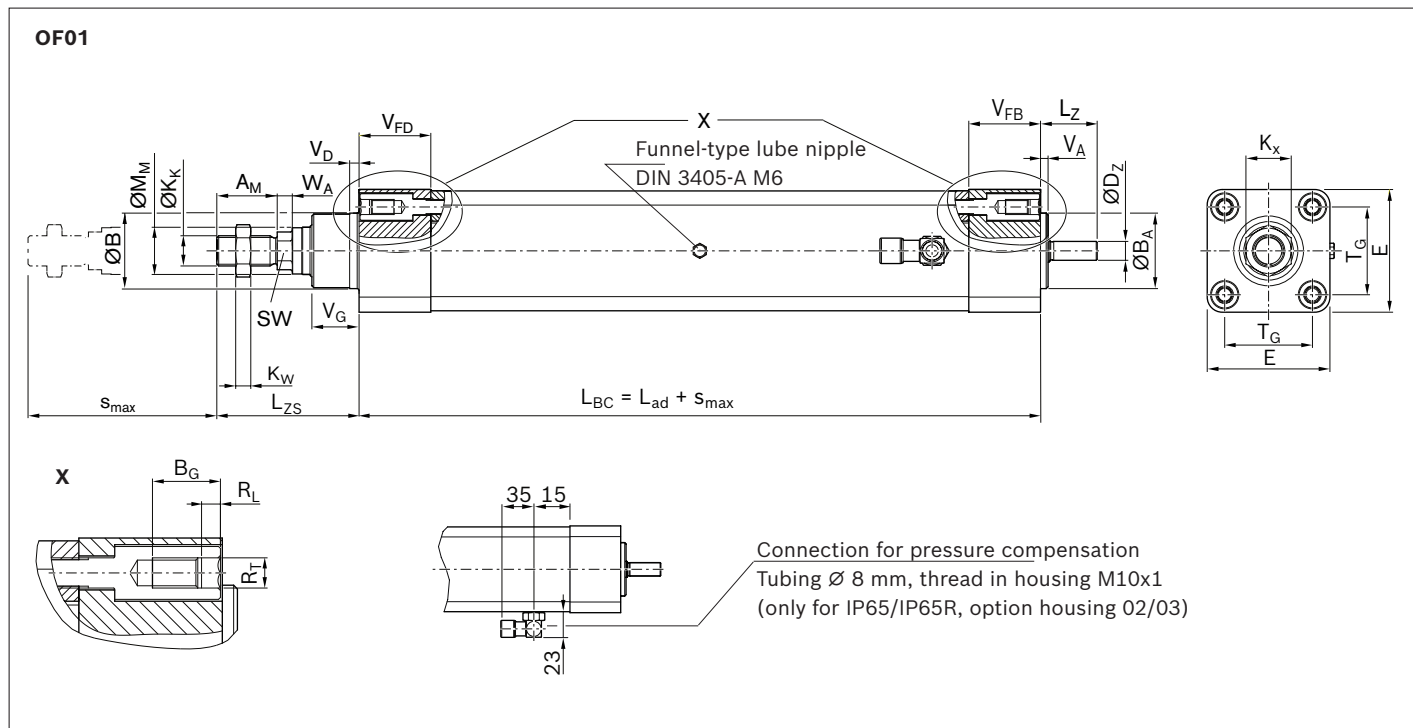

EMC	BASA $d_0 \times P$	Dimensions (mm)							
		A_M -0.1	B_{d11} / B_A h7	D^Z h7	E ± 0.1	K_K	K_W	K_X	L_{zs}
32	12 x 5	22	30	5	47	M10x1.25	6	17	55.00
	12 x 10								
40	16 x 5	24	35	8	53	M12x1.25	7	19	61.50
	16 x 10								
	16 x 16								
50	20 x 5	32	40	10	65	M16x1.5	8	24	76.75
	20 x 10								
	20 x 20								
63	25 x 5	32	45	15	75	M16x1.5	8	24	76.50
	25 x 10								
	25 x 25								
80	32 x 5	40	55	18	95	M20x1.5	10	30	94.50
	32 x 10								
	32 x 20								
	32 x 32								
100	40 x 5	40	65	25	115	M20x1.5	10	30	99.25
	40 x 10								
	40 x 20								
	40 x 40								
100XC	50 x 10	72	75	32	115	M36x2	18	55	144.00
	50 x 20								

Effective stroke

Excess travel must be greater than braking distance. The acceleration travel can be taken as a guideline value for braking distance.

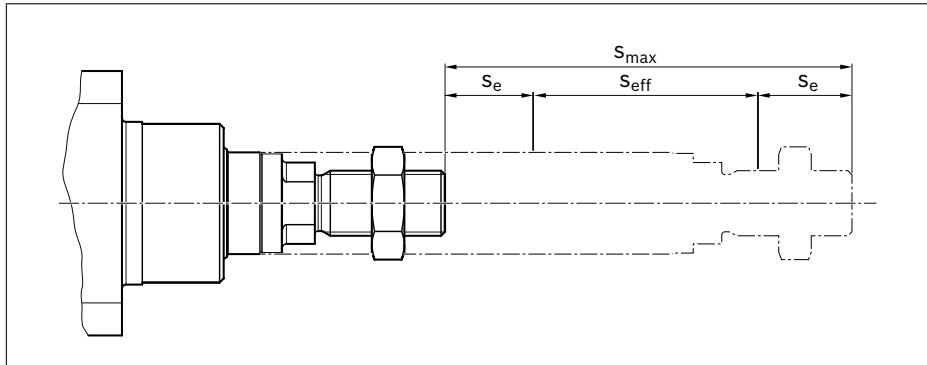

$$S_{\text{eff}} = S_{\text{max}} - 2 \cdot S_e$$

- S_e = Excess travel (mm)
- S_{eff} = Effective stroke (mm)
- S_{max} = Maximum travel (mm)

Length calculation:

Overall length of EMC for motor attachment with flange and coupling = $L_{zs} + S_{\text{max}} + L_{\text{ad}} + L_f + L_m$

Overall length of EMC for motor attachment with belt side drive = $L_{zs} + S_{\text{max}} + L_{\text{ad}} + G$

(for L_f , L_m and G , see following page)

	L_{ad}	L_z	$M_{\text{M f8}}$	R_T	B_G	R_L	SW	T_G	V_A ± 0.1	V_D	V_{FB}	V_{FD}	V_G ± 0.1	W_A				
	132	18	18	M6	18	4	10	32.5	4	5	30	30	16	6				
	136																	
	134	25	20	M6		4	13	38.0			4	5	33	30	20	6		
	143																	
	159																	
	142	30	25	M8		5	17	46.5			4	5	38	38	25	8		
	161																	
	180																	
	148	35	30	M8		5	17	56.5			4	5	40	38	25	8		
	167																	
	199																	
	163	46	38	M10		22	6	22			72.0	4	5	44	45	33	10	
	187																	
	195																	
	230																	
	171	57	50	M10	6		22	89.0	4	5	54			45	38	10		
	185																	
	203																	
	258																	
	316	62	60	M12	7		36	89.0			4			5	121	62	38	18
	338																	

Dimension drawing for motor attachment with flange and coupling

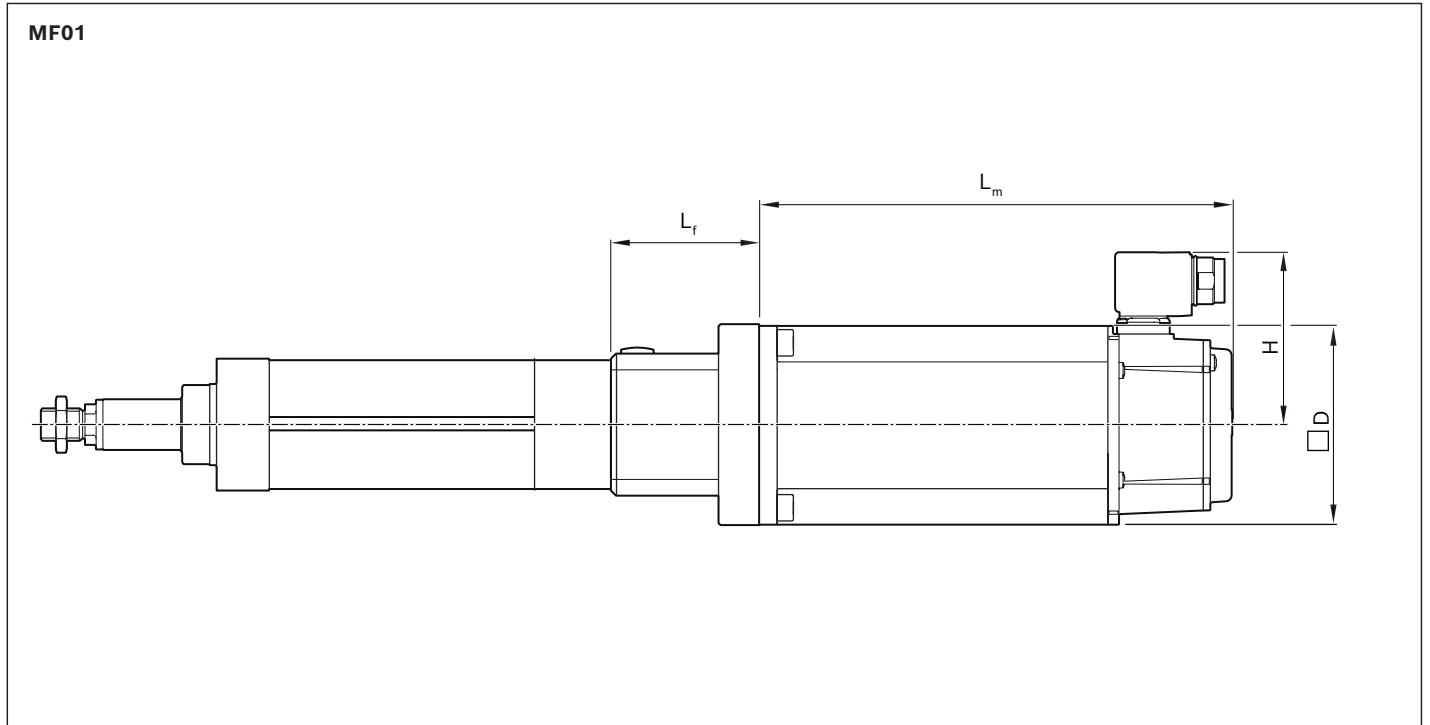

Dimension drawing motor attachment with belt side drive

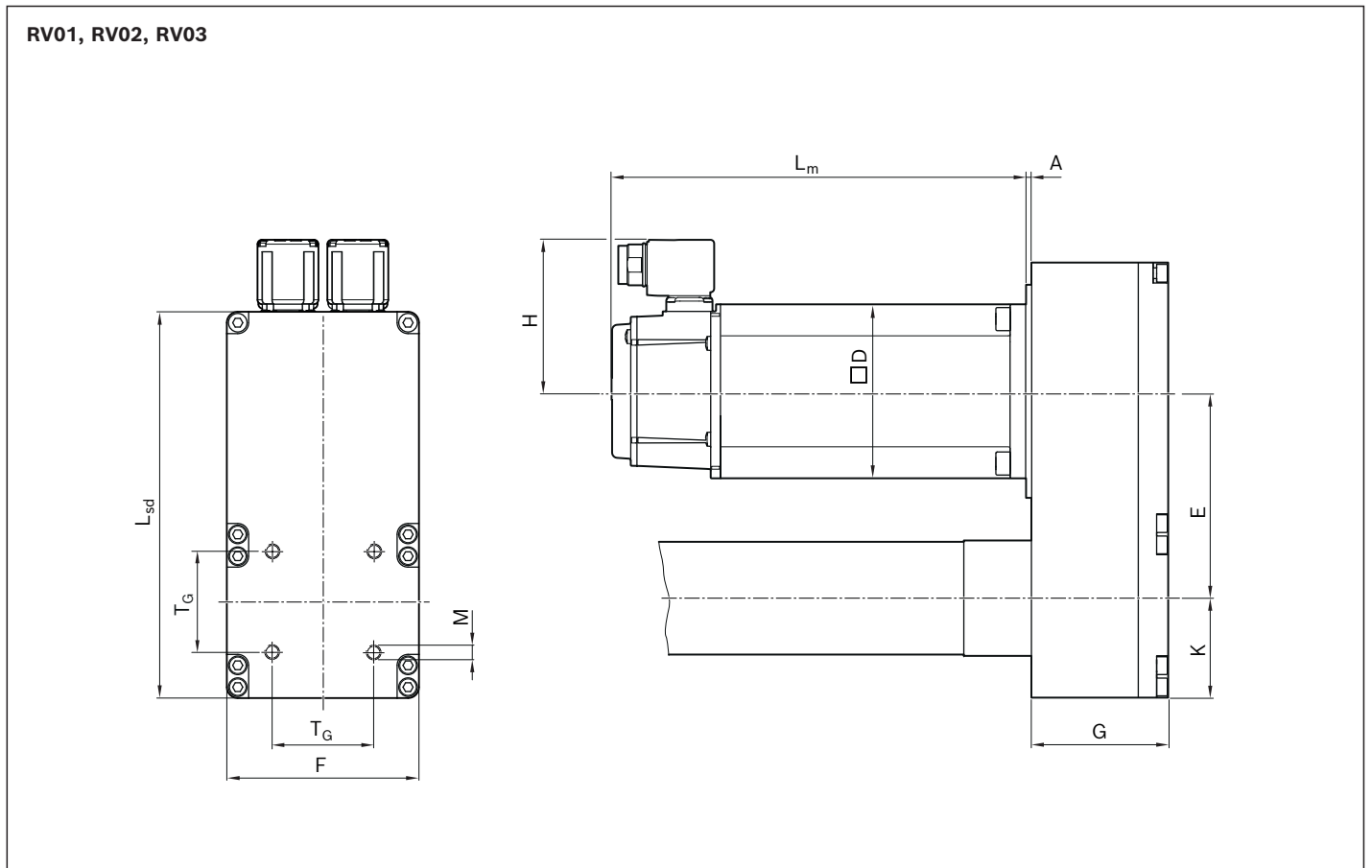

EMC	for motor	i	Dimensions (mm)													Max. permissible screw-in depth ¹⁾				
			A	E	K	G	□ D	H	without brake	L _m with brake	L _{sd}	L _f	F	T _G	M					
32	MSM019B	1	2.0	67.3	30.5	37.0	38	32.0	92.0	122.0	130	55	54.0	32.5	M6	10.5				
	MSM031B	1	2.0	62.8	33.0	45.5	60	43.0	79.0	115.5	138		64.5			16.0				
	MS2N03B	1	-				54	71.5	188.0	213.0										
40	MSM031C	1	2.0	62.8	33.0	45.5	60	42.0	98.5	135.0	138	61	64.5	38.0	M6	16.0				
		1.5	2.0	65.3																
	MS2N03B	1	-	62.8	54	71.5	188.0	213.0												
		1.5	-	65.3																
	MS2N04	1	-	82.2	44.0	55.5	82	83.5	185.5	215.5	177	88.0								
1.5		-	81.5																	
50	MSM031C	1	0.5	82.2	44.0	55.5	60	43.0	99.0	135.0	177	73	88.0	46.5	M8	16.0				
		1.5	0.5	81.5																
	MSM041B	1	3.0	82.2			80	53.0	112.0	149.0										
		1.5	3.0	81.5																
	MS2N04	1	-	82.2			82	83.5	185.5	215.5										
		1.5	-	81.5																
MS2N05	1	3.0	117.2	56.0	77.0	96	85.5	203.0	233.0	245	116.0									
63	MSM041B	1	3.0	117.2	56.0	77.0	80	53.0	112.0	149.0	245	95	116.0	56.5	M8	16.0				
		2	3.0	116.2																
	MS2N04	1	3.0	117.2			82	83.5	185.5	215.5										
		2	3.0	116.2																
	MS2N05	1	3.0	117.2			98	85.5	203.0	233.0										
		2	3.0	116.2																
MS2N06	1	-	117.2	116	98.5	226.0	259.0													
80	MS2N05	1	3.0	116.2	56.0	77.0	98	85.5	203.0	233.0	245	100	116.0	72.0	M10	16.0				
		2	3.0	117.2																
	MS2N06	1	2.5	149.7	116	98.5	226.0	259.0												
		2	2.5	151.4																
MS2N07	1	6.0	149.7	77.0	102.0	140	110.0	292.5	292.5	324	110	160.0								
100	MS2N06	1	2.5	149.7	77.0	102.0	116	98.5	226.0	259.0	324	119	160.0	89.0	M10	16.0				
		2	2.5	151.4																
	MS2N07	1	3.0	149.7													140	110.0	292.5	292.5
		2	3.0	151.4																
100XC	MS2N07	1	3.0	174.7	89.0	113.5	140	132.0	352.0	387.0	375	143	197.0	89.0/ 140.0	M12/ M16	24.0				
		1.5	3.0	175.6																
	MS2N10	1	4.0	174.7			192	166.0	410.0	410.0										
		1.5	4.0	175.6																

¹⁾ Do not exceed max. permissible screw-in depth for "M" threads

Fastener

⚠ When you order an EMC with flange, motor and foot mounting or trunnion on the bottom, the unit is delivered fully assembled. When assembling these fastening elements retrospectively to the cylinder base, the flange first needs to be disassembled.

The "Instructions EMC", R320103102 that are part of the product must be observed.

The fastening elements are mounted on the rear of the belt side drive. The screws are included with the fastening elements.

Before mounting the fastening elements, remove the set screws on the belt side drive.

Examples

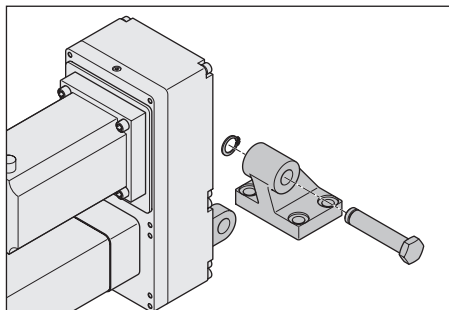
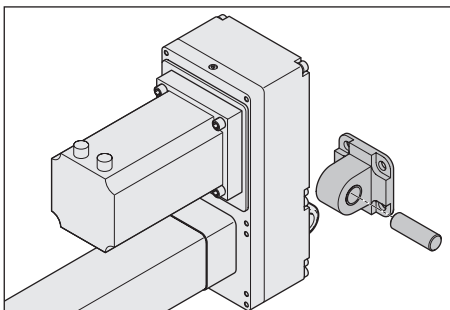
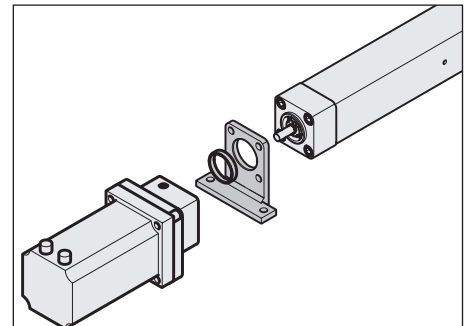
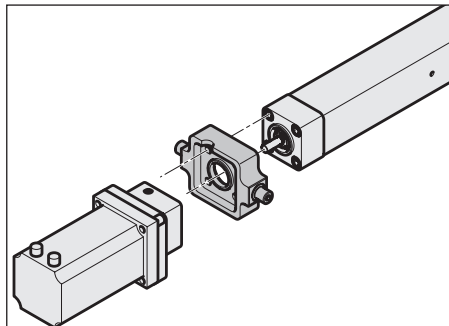
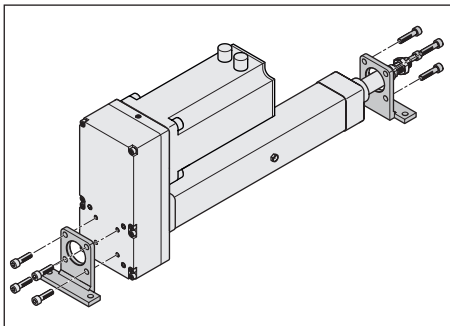
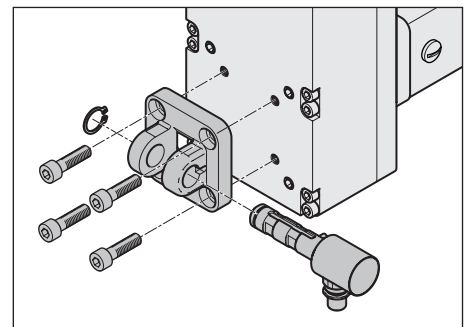
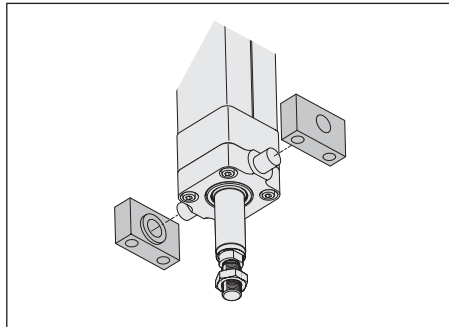
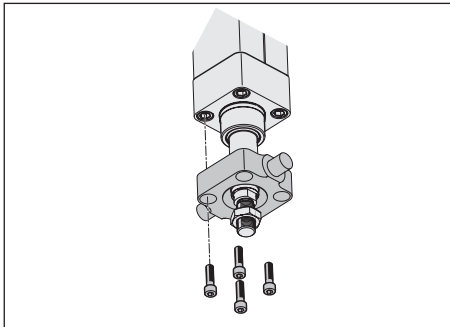
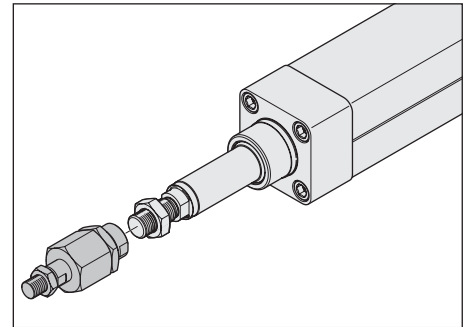
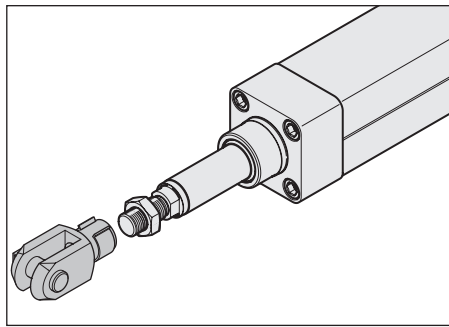
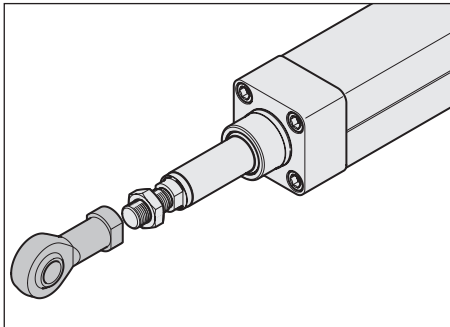

Fastening elements

Female spherical rod end bearing

Group 2
Option 01
Galvanized steel

Group 2
Option 07
Stainless steel

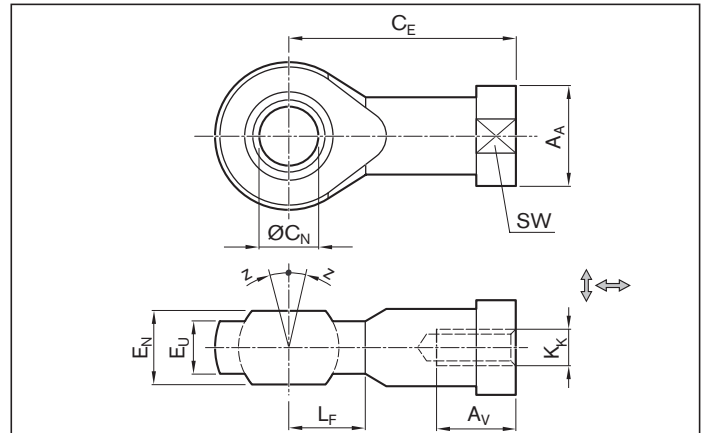

EMC	Material number		Dimensions (mm)										m (kg)
	Steel galvanized	Stainless steel	A _A	A _V min.	C _E	ØC _N H7	E _N -0.1	E _U max.	K _K	L _F	SW	Z (°)	
32	R349938500	R349951600	19	15	43	10	14	11.5 (10.5)	M10x1.25	14	17	4 (7)	0.070 (0.10)
40	R349938600	R349951700	22	18 (16)	50	12	16	12.5 (12)	M12x1.25	16	19	4 (7)	0.105 (0.12)
50	R349938700	R349951800	29	24	64	16	21	15.5 (15)	M16x1.5	21	24	4 (8)	0.210 (0.23)
63													
80	R349938900	R349951900	34	30 (33)	77	20	25	18.5 (18)	M20x1.5	25	30 (32)	4 (8)	0.380 (0.42)
100													
100XC	R349951500	R349952000	60 (53)	56 (53)	125	35	43 (35)	32 (24)	M36x2	40 (37)	50 (-)	4 (6)	2.000 (1.40)

Bracketed values for "stainless steel" version

Fastening elements

Hexagon nut

One included with the EMC

Group 2 Option 05 Galvanized steel	Group 2 Option 06 Stainless steel
--	---

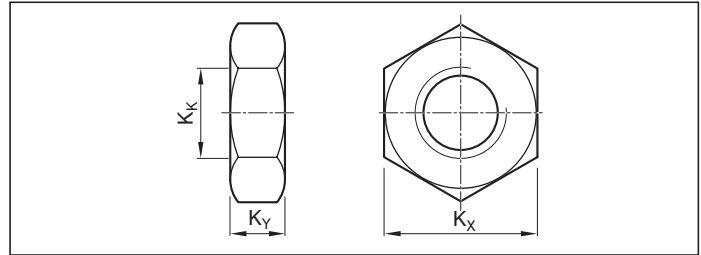

EMC	Material number		Dimensions (mm)			m (kg)
	Galvanized steel	Stainless steel	K _k	K _x	K _y	
32	1823A00020	2990600303	M10x1.25	17	6 (5)	0.010
40	1823A00021	2990600304	M12x1.25	19	6	0.012
50	1823300030	2990600305	M16x1.5	24	8	0.017
63						
80	1823300031	2990600308	M20x1.5	30	10	0.030
100						
100XC	8103190414	2990600316	M36x2	55 (50)	18 (16)	0.175 (0.15)

Bracketed values for "stainless steel" version

Fork clevis with internal thread

Material: Galvanized steel

Group 2
Option 02

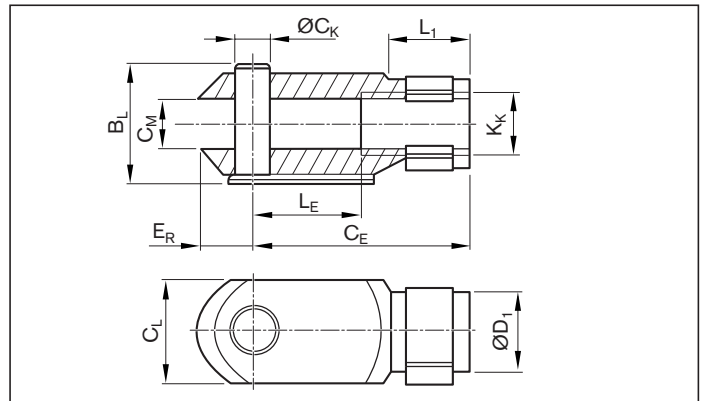

EMC	Material number	Dimensions (mm)										m (kg)
		B _L	C _E	ØC _k e11	C _L	C _M	ØD ₁	E _R	K _k	L ₁	L _E	
32	R349939100	26	40	10	20	10	18	12	M10x1.25	15.0	20	0.10
40	R349939200	31	48	12	24	12	20	14	M12x1.25	18.0	24	0.15
50	R349939300	39	64	16	32	16	26	19	M16x1.5	24.0	32	0.35
63												
80	R349939500	50	80	20	40	20	34	20	M20x1.5	30.0	40	0.70
100												
100XC	R349951000	80	144	35	70	35	60	57	M36x2	54.5	72	1.40

Flexible coupling with fastening plate

Material: Galvanized steel

Group 2
Option 03

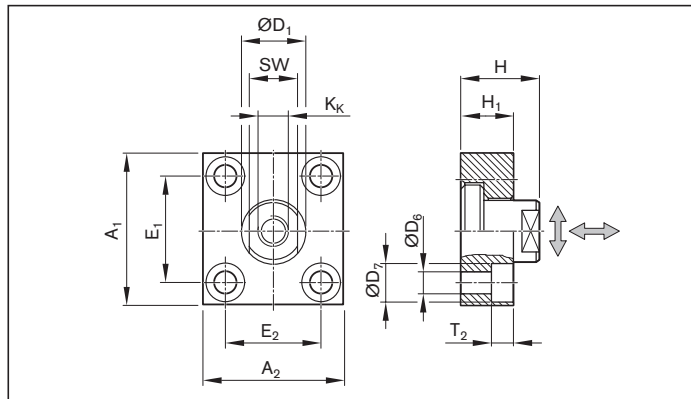

EMC	Material number	Dimensions (mm)												m (kg)	F _{max} (N)		
		A ₁	A ₂	ØD ₁ H11	ØD ₆ H13	ØD ₇ H13	E ₁	E ₂	H ₁	H	K _K	SW	T ₂			Clearance (min./max)	
														↔ axial	↕ radial		
32	R349939700	60	37	20	6.6	11	36±0.15	23±0.15	15	24	M10x1.25	17	7	0.4 – 0.8	1.9 – 2.3	0.30	F _{max} EMC
40	R349939800	60	56	25	9.0	15	42±0.20	38±0.20	20	30	M12x1.25	19	9			0.40	F _{max} EMC
50	R349939900	80	80	30	11.0	18	58±0.20	58±0.20	20	32	M16x1.5	24	11			0.90	F _{max} EMC
63		80	80	30	11.0	18	58±0.20	58±0.20	20	32	M16x1.5	24	11			0.90	F _{max} EMC
80	R349940100	90	90	40	14.0	20	65±0.30	65±0.30	20	35	M20x1.5	36	13			1.15	F _{max} EMC
100		90	90	40	14.0	20	65±0.30	65±0.30	20	35	M20x1.5	36	13	1.15	28 000		
100XC	R349951100	125	125	60	18.0	26	90±0.30	90±0.30	30	55	M36x2	50	17	0.4 – 0.95	2.8 – 3.4	3.40	44 000

Flexible coupling

Material: Galvanized steel

Group 2
Option 04

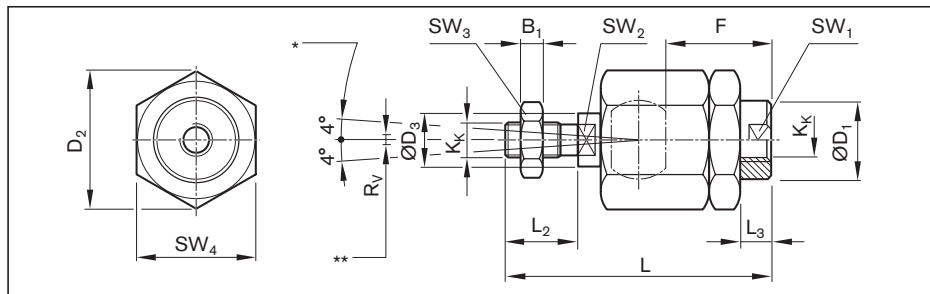
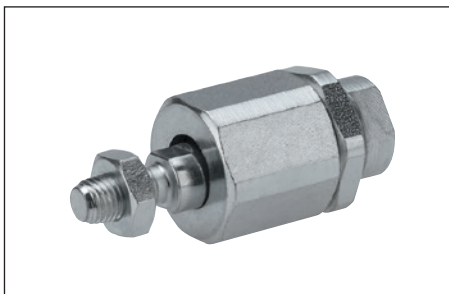

*) Axial angle equalization

**) Radial compensation

EMC	Material number	Dimensions (mm)														m (kg)	F _{max} (N)	
		B ₁	ØD ₁	D ₂	ØD ₃	F	K _K	L ±2	L ₂	L ₃ ±1	SW ₁	SW ₂	SW ₃	SW ₄	R _V			Axial backlash
32	R349937900	6	22	32	14	23	M10x1.25	74.5	23	7.5	19	12	17	30	0.7	0.05 – 0.5	0.21	F _{max} EMC
40	R349938000	7	22	32	14	22	M12x1.25	75.0	24	13.0	19	12	19	30	0.7	0.05 – 0.5	0.21	F _{max} EMC
50	R349938100	8	32	45	22	30	M16x1.5	103.0	30	9.0	30	20	24	41	1.0	0.05 – 0.5	0.65	F _{max} EMC
63		8	32	45	22	30	M16x1.5	103.0	30	9.0	30	20	24	41	1.0	0.05 – 0.5	0.65	10 300
80	R349938300	10	32	45	22	40	M20x1.5	119.0	40	19.0	30	20	30	41	1.0	0.05 – 0.5	0.68	10 300
100		10	32	45	22	40	M20x1.5	119.0	40	19.0	30	20	30	41	1.0	0.05 – 0.5	0.68	10 300
100XC	R349950900	18	80	80	38	86	M36x2	241	72	18.2	50	36	55	75	1.5	0.05 – 0.2	5.40	15 000

Radial clearance 0 – 2 mm

Fastening elements

Bearing for trunnion

Material: Galvanized steel, with female connectors made of sintered bronze. Delivered in pairs

Group 3
Option 03

Group 5
Option 03

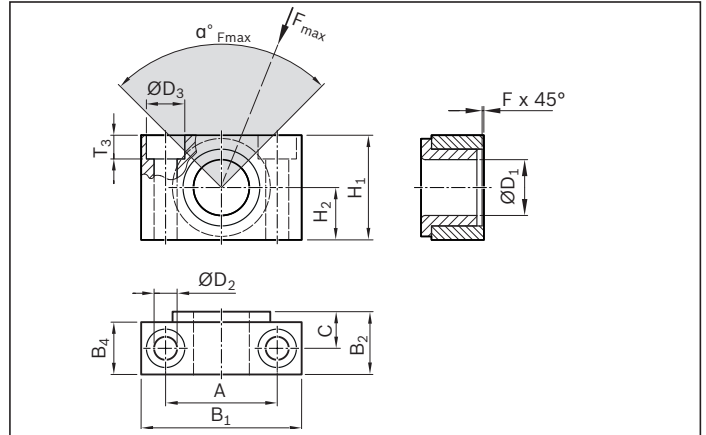

Note: Bearing for trunnion for vertical load; if αF_{max} is not complied with, a positive lock must be added

EMC	Material number	Dimensions (mm)											αF_{max}	
		A ±0.2	B ₁ f8	B ₂	B ₄	C	ØD ₁ H7	ØD ₂ H12	ØD ₃ H13	F x 45°	H ₁	H ₂ ±0.1		T ₃ -0.4
32	R349940900	32	46	18.0	15	10.5	12	6.6	11	1.0	30	15	6.8	180
40	R349941000	36	55	21.0	18	12.0	16	9.0	15	1.6	36	18	9.0	180
50														180
63	R349941200	42	65	23.0	20	13.0	20	11.0	18	1.6	40	20	11.0	110
80														70
100	R349941400	50	75	28.5	25	16.0	25	14.0	20	2.0	50	25	13.0	80
100XC														30

Trunnion for cover (only for vertical installation of EMC)

Material: Galvanized cast iron with spheroidal graphite. Fastening screws included in scope of delivery.

Group 3
Option 01

Group 3
Option 03

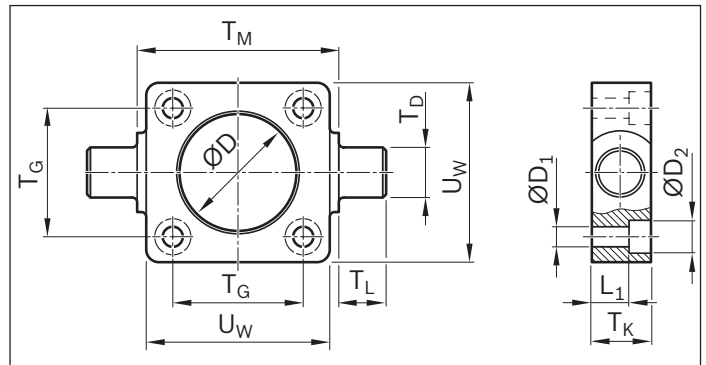
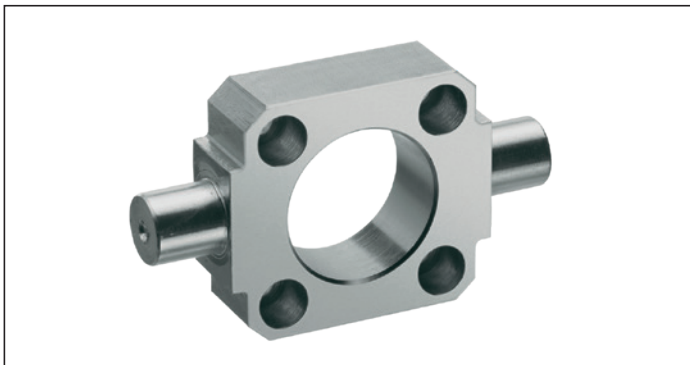

EMC	Material number	Dimensions (mm)										m (kg)
		ØD H11	ØD ₁	ØD ₂	L ₁	T _D e9	T _G ±0.2	T _K	T _L h14	T _M h14	U _W	
32	R349940300	30	6.6	11	7.5	12	32.5	16	12	50	48	0.29
40	R349940400	35	6.6	11	7.5	16	38.0	20	16	63	56	0.50
50	R349940500	40	9.0	15	10.0	16	46.5	24	16	75	65	0.70
63	R349940600	45	9.0	15	10.0	20	56.5	24	20	90	75	1.10
80	R15615A001	55	11.0	18	16.0	20	72.0	28	20	110	100	1.50
100	R15616A001	65	11.0	18	25.5	25	89.0	38	25	132	120	2.70
100XC	R15617A001	75	13.5	20	25.5	25	89.0	38	25	132	120	3.88

Trunnion, for base

Material: Galvanized steel. Fastening screws included in scope of delivery.

Group 5
Option 01

Group 5
Option 03

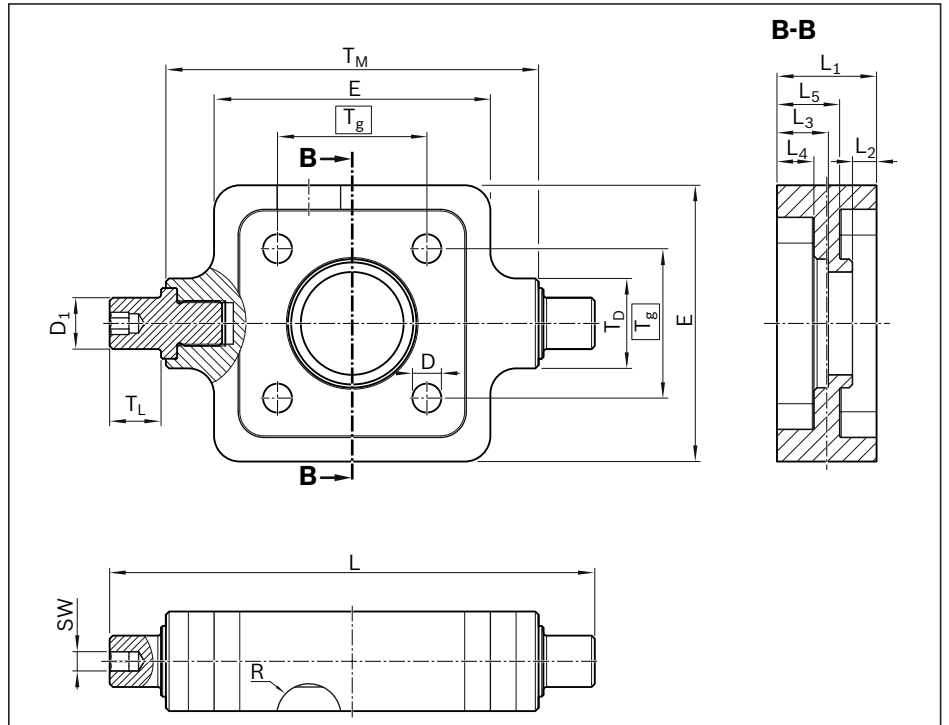
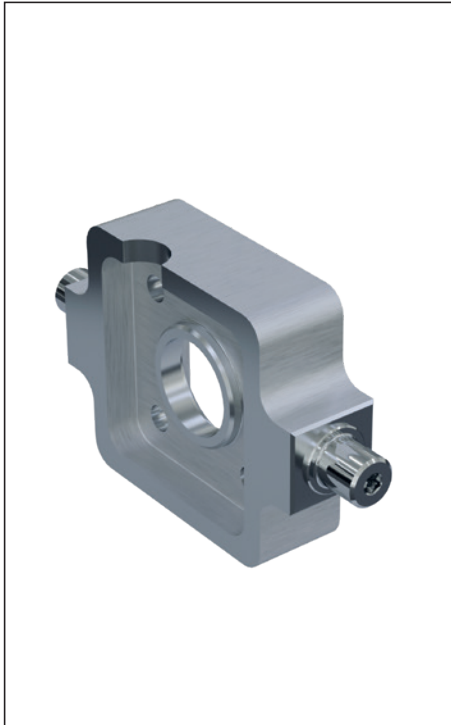

EMC	Material number	Dimensions (mm)															m
		$\varnothing D$ H13	$\varnothing D_1$ h7	L	L ₁ ±0.5	L ₂ ±0.2	L ₃ ±0.2	L ₄ ±0.5	L ₅ ±0.5	T _D ±0.5	T _g	T _M ±0.3	T _L ±0.2	E ±0.5	R	SW	
32	R15611B013	6.6	12	115	25	5.5	14.0	9.5	15.5	22	32.5	90	12	60	10	6	0.472
40	R15612B013	6.6	16	135	28	6.5	15.0	10.5	17.5	28	38.0	100	16	65	10	6	0.657
50	R15613B013	9.0		151	31	7.5	16.0	11.5	19.5	28	46.5	116		86	10		1.141
63	R15614B013	9.0	20	173	35	7.5	16.5	11.5	23.5	35	56.5	130	20	90	10	8	1.468
80	R15615B013	11.0		193	36	7.5	16.5	11.5	24.5	38	72.0	150		105	10		2.079
100	R15616B013	11.0	25	233	38	7.5	16.5	11.5	26.5	38	89.0	180	25	125	10	12	2.725
100XC	R15617B013	13.5	25	253	44	7.5	16.5	11.5	32.5	45	89.0	200	25	140	11	12	4.480

Fastening elements

Flange fastening

Material: Galvanized steel. Fastening screws included in scope of delivery.

Group 3
Option 04

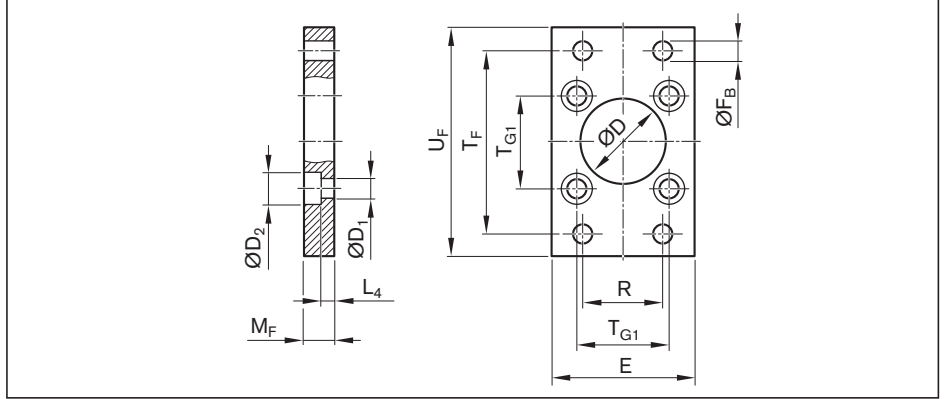

EMC	Material number	Dimensions (mm)											m
		ØD	ØD1	ØD2	E	ØFB	L4	MF	R	TF	TG1	UF	
		H11	H13	H13	max.			±0.1	±0.2	±0.2	±0.2	±0.2	
32	R349942100	30	6.6	11	50	7.0	4.5	10	32	64	32.5	80	0.3
40	R349942200	35	6.6	11	55	9.0	4.5	10	36	72	38.0	90	0.4
50	R349942300	40	9.0	15	65	9.0	6.0	12	45	90	46.5	110	0.8
63	R349942400	45	9.0	15	75	9.0	6.0	12	50	100	56.5	125	1.0
80	R15615A002	55	11.0	18	100	12.0	9.0	16	63	126	72.0	154	1.7
100	R15616A002	65	11.0	18	120	14.0	9.0	16	75	150	89.0	186	2.4
100XC	R15617A002	75	13.5	20	120	17.5	12.6	24	75	150	89.0	186	3.0

Foot mounting for assembly on the cover or belt side drive

Material: Galvanized steel
Fastening screws included in scope of delivery

Group 3 Option 06 Group 5 Option 06

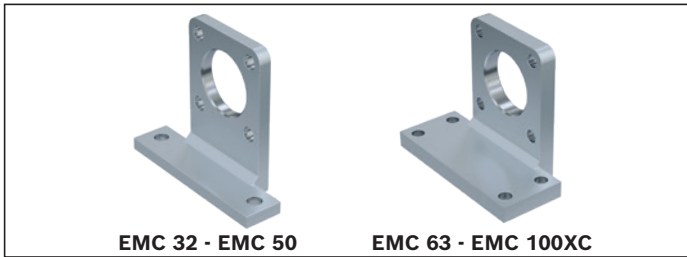

EMC	Material number	m (kg)
32	R15611B105	0.166
40	R15612B105	0.246
50	R15613B105	0.459
63	R15614B105	1.038
80	R15615B105	1.952
100	R15616B105	2.793
100XC	R15617B105	4.147

Foot mounting with centering ring for mounting on the base

Material: Galvanized steel
Fastening screws included in scope of delivery

Group 5 Option 05

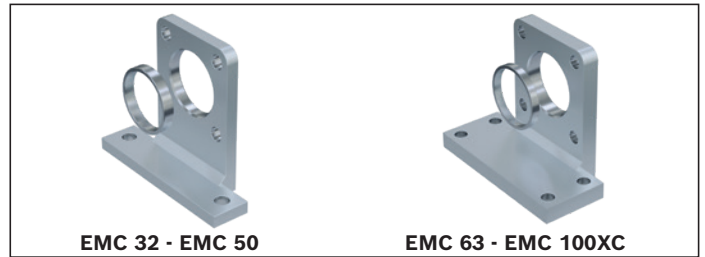

EMC	Material number	m ¹⁾ (kg)
32	R15611B104	0.172
40	R15612B104	0.252
50	R15613B104	0.465
63	R15614B104	1.047
80	R15615B104	1.962
100	R15616B104	2.805
100XC	R15617B104	4.165

¹⁾ including the weight of the centering ring

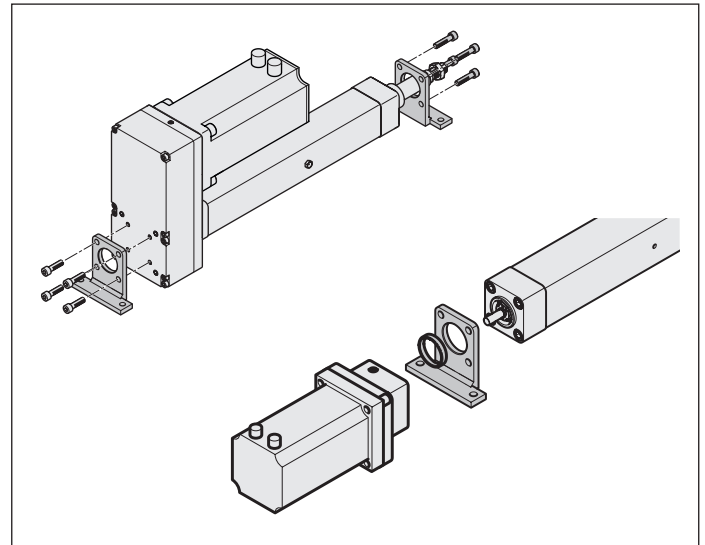
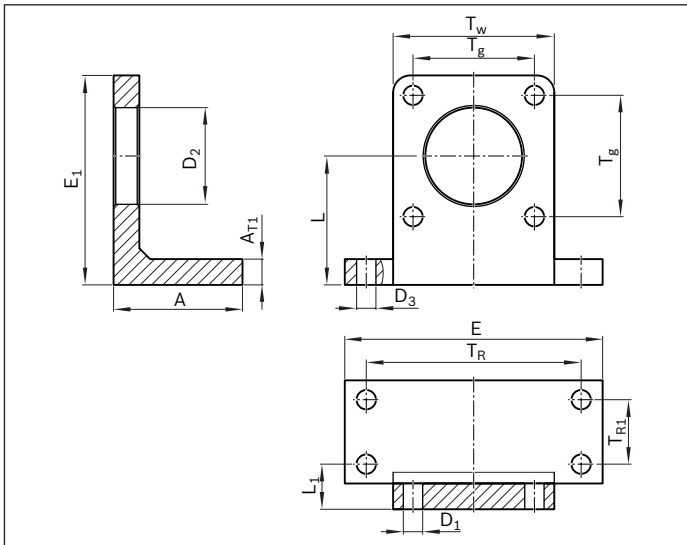

EMC	Dimensions (mm)												
	A ±0.5	AT1 ±0.5	ØD1 H13	ØD2 H7	ØD3 H13	E ±0.5	E1 ±0.5	L ±0.1	L1	TR	TR1	Tg	TW ±0.5
32	30	6	6.6	30	6.6	79	57.5	34	18	65	-	32.5	47
40	30	7	6.6	35	9.0	90	71.5	45	18	75	-	38.0	53
50	35	8	9.0	40	9.0	110	93.5	60	21	90	-	46.5	65
63	50	12	9.0	45	9.0	120	98.5	60	21	100	20	56.5	75
80	62	13	11.0	55	11.0	153	129.5	82	27	128	25	72.0	95
100	72	15	11.0	65	14.0	178	140.5	82	27	148	30	89.0	115
100XC	90	21	13.5	75	17.5	188	156.5	99	33	158	45	89.0	115

Fastening elements

Clevis mount

Bolts and fastening screws included in scope of delivery

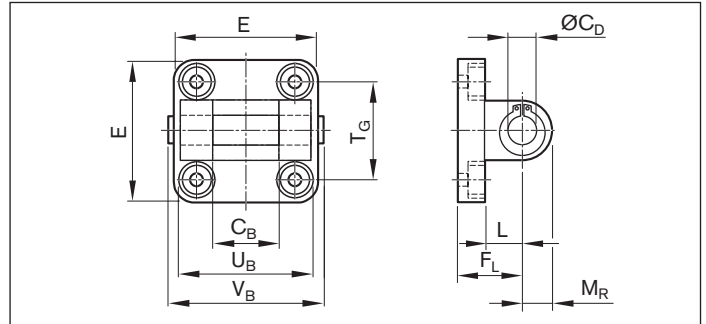
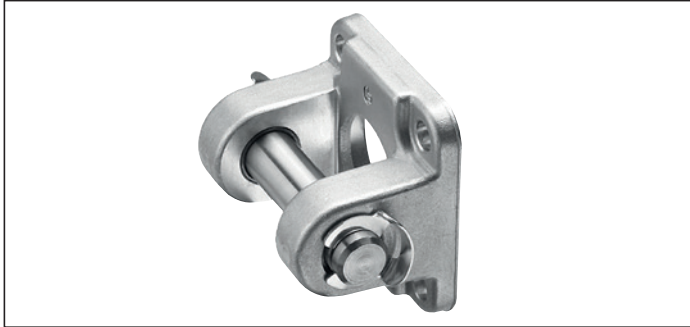
Group 5
Option 07

EMC	Material number	Dimensions (mm)									m (kg)	F _{max} (N)
		C _B H14	ØC _D H9	E max.	F _L ±0.2	L min.	M _R	T _G ±0.2	U _B h14	V _B		
32	R349945700 ¹⁾	26	10	49	22	12	10	32.5	45	50.0	0.09	F _{max} EMC
40	R349945800 ¹⁾	28	12	53	25	15	13	38.0	52	57.0	0.11	F _{max} EMC
50	R349945900 ¹⁾	32	12	63	27	15	13	46.5	60	65.0	0.18	F _{max} EMC
63	R349946000 ¹⁾	40	16	73	32	18	17	56.5	70	76.0	0.25	10 900
80	R349946100 ¹⁾	50	16	98	36	20	17	72.0	90	96.0	0.51	13 100
100	R349946200 ¹⁾	60	20	115	41	25	18	89.0	110	117.0	0.70	16 400
100XC	R15617B026 ²⁾	90	30	177	55	35	31	140.0	170	180.5	2.14	F _{max} EMC

1) Material: Aluminum

2) Material: Galvanized cast iron with spheroidal graphite

Swivel mount

Fastening screws included in scope of delivery

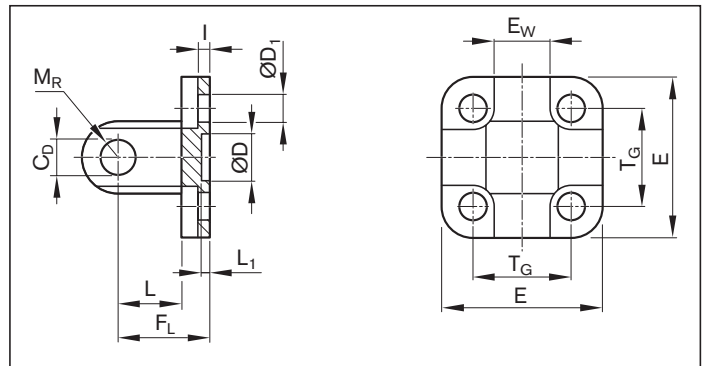
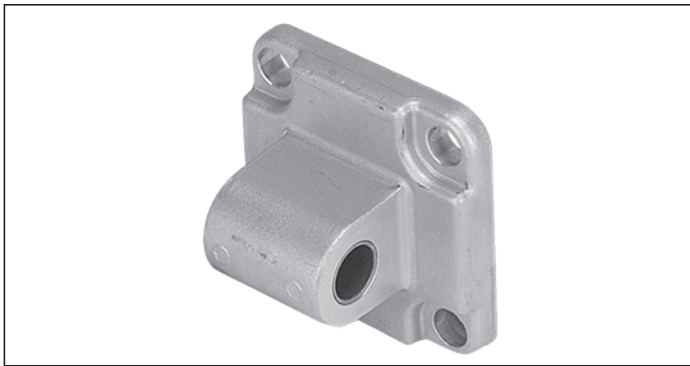
Group 6
Option 02

EMC	Material number	Dimensions (mm)											m (kg)	F _{max} (N)	
		C _D H9	ØD H11	D ₁ H13	E	E _w -0.2/-0.6	F _L ±0.2	I ±0.5	L min.	L ₁ min.	M _R max.	T _G ±0.2			DIN 912
32	R349948100 ¹⁾	10	30	6.6	48	26	22	5.5	12	4.5	10	32.5	M6x18	0.08	F _{max} EMC
40	R349948200 ¹⁾	12	35	6.6	53	28	25	5.5	15	4.5	12	38.0	M6x18	0.11	F _{max} EMC
50	R349948300 ¹⁾	12	40	9.0	63	32	27	6.5	15	4.5	12	46.5	M8x20	0.17	F _{max} EMC
63	R349948400 ¹⁾	16	45	9.0	73	40	32	6.5	20	4.5	16	56.5	M8x20	0.27	10 900
80	R349948500 ¹⁾	16	45	11.0	98	50	36	10.0	20	4.5	16	72.0	M10x20	0.50	13 100
100	R349948600 ¹⁾	20	55	11.0	115	60	41	10.0	25	4.5	20	89.0	M10x20	0.77	16 400
100XC	1827004867 ²⁾	30	65	13.5	180	90	55	10.0	35	7.0	31	140±0.3	M16x50	2.60	F _{max} EMC

1) Material: Aluminum

2) Material: Galvanized cast iron with spheroidal graphite

Bearing block

Material: Galvanized cast iron with spheroidal graphite. Without fastening screws

Group 6
Option 01

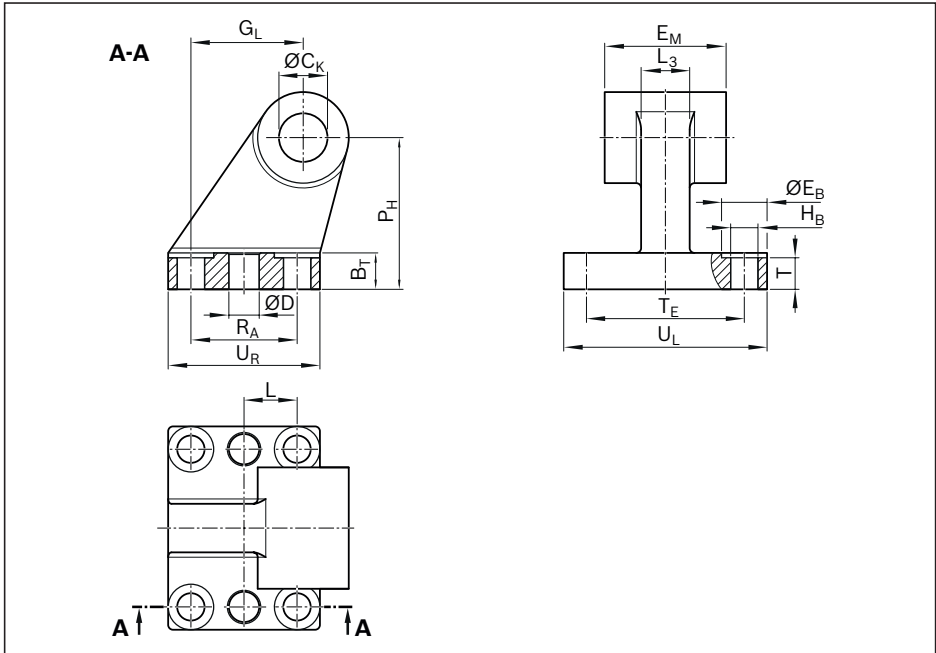
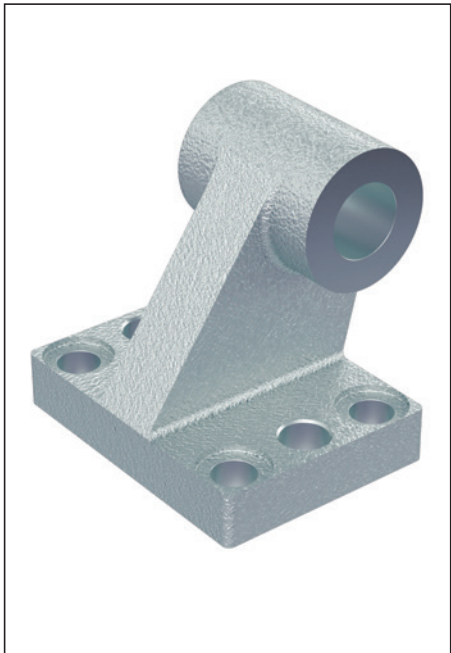

EMC	Material number	Dimensions (mm)																m (kg)
		BR	BT	ØCK H9	ØD H11	ØEB H13	EM -0.2 -0.6	GL	ØHB H13	L ±0.2	L3	PH JS15	RA JS14	T	TE JS14	UL	UR	
32	R349947500	10.0	8	10	-	10	26	21	6.6	-	10	32	18	4	38	51	31	0.20
40	R349947600	11.0	10	12	-	10	28	24	6.6	-	12	36	22	4	41	54	35	0.30
50	R349947700	13.0	12	12	-	11	32	33	9.0	-	16	45	30	6	50	65	45	0.50
63	R15614A017	15.0	12	16	10	11	40	37	9.0	17.5	16	50	35	6	52	67	50	0.85
80	R15615A017	15.0	14	16	10	15	50	47	9.0	20.0	20	63	40	6	66	86	60	1.40
100	R15616A017	19.0	15	20	10	15	60	55	11.0	25.0	20	71	50	6	76	96	70	1.90
100XC	R15617A017	31.5	25	25	12	26	90	97	14.0	44.0	36	115	88	17	118	156	126	1.90

Fastening elements

Clevis mount

Bolts and fastening screws included in scope of delivery

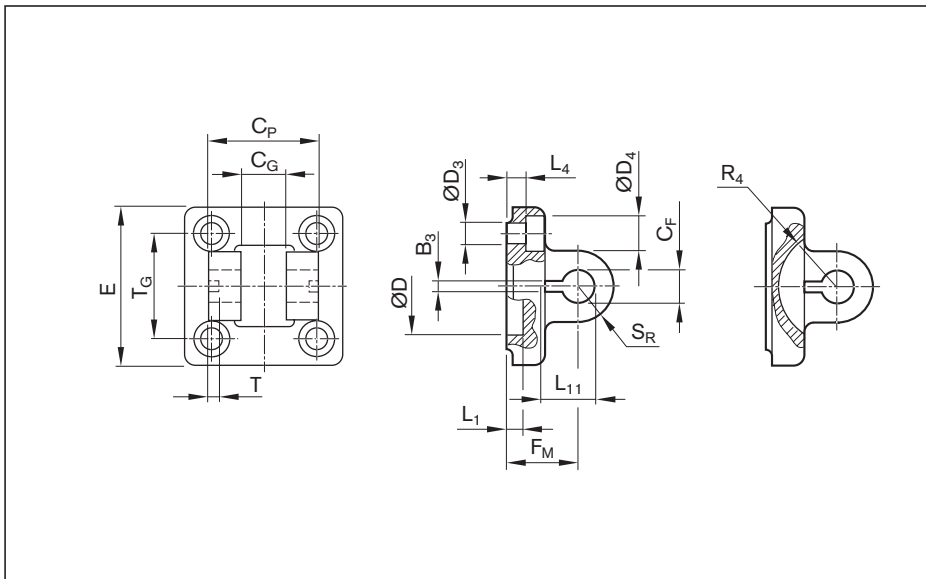
Group 1
Option 01Group 5
Option 08

EMC	Material number	Dimensions (mm)																	m (kg)	F _{max} (N)
		B ₃ ±0.2	C _F F7	C _G D10	C _P d12	ØD ₃	ØD ₄	ØD	E	F _M ±0.2	L ₁ ±0.5	L ₄ ±0.5	L ₁₁ -0.5	R ₄	S _R	T ±0.2	T _G ±0.2	DIN 912		
32	R349945100 ¹⁾	3.3	10	14	34	6.6	11	30	49	22	4.5	5.5	16.5	17	11	3	32.5	M6x18	0.22	F _{max} EMC
40	R349945200 ¹⁾	4.3	12	16	40	6.6	11	35	55	25	4.5	5.5	18.0	20	12	4	38.0	M6x18	0.29	F _{max} EMC
50	R349945300 ¹⁾	4.3	16	21	45	9.0	15	40	67	27	4.5	6.5	23.0	22	15	4	46.5	M8x20	0.49	F _{max} EMC
63	R349945400 ¹⁾	4.3	16	21	51	9.0	15	45	77	32	4.5	6.5	23.0	25	15	4	56.5	M8x20	0.68	14 500
80	R349945500 ¹⁾	4.3	20	25	65	11.0	18	45	97	36	4.5	10.0	27.0	30	20	4	72.0	M10x20	1.39	17 800
100	R349945600 ¹⁾	4.3	20	25	75	11.0	18	55	117	41	4.5	10.0	27.0	32	20	4	89.0	M10x20	2.04	22 900
100XC	1827001600 ²⁾	6.3	35	43	122	18.0	26	65	180	55	10.0	10.0	45.0	46	26	6	140.0	M16x50	2.13	F _{max} EMC

¹⁾ Material: Aluminum (forged)²⁾ Material: Galvanized spheroidal graphite iron

Swivel bearing

Fastening screws included in scope of delivery

Group 6
Option 04

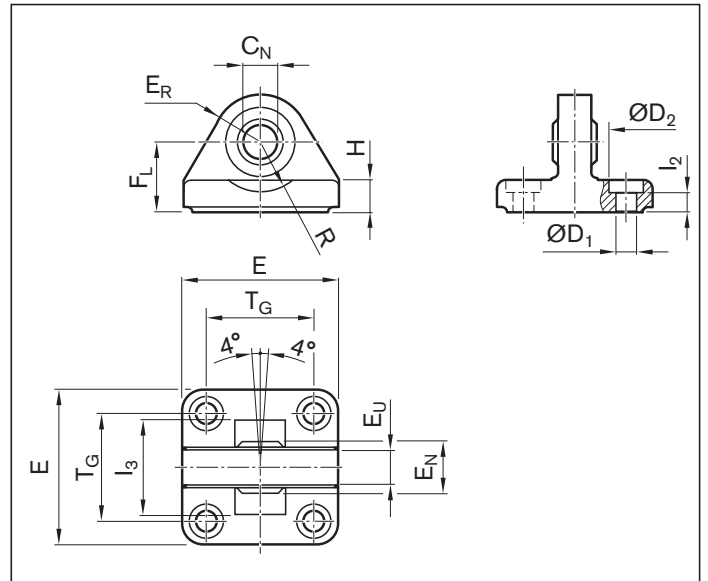

EMC	Material number	Dimensions (mm)														m (kg)	F _{max} (N)
		ØC _N H7	ØD ₁ H13	ØD ₂ H13	E	E _N -0.1	E _R	E _U	F _L -0.2	H	l ₂	l ₃ min.	R	T _G ±0.2	DIN 912		
32	R349946900 ¹⁾	10	6.6	11	47	14	15	10.5	22	9.0	5.5	36	12	32.5	M6x18	0.21	F _{max} EMC
40	R349947000 ¹⁾	12	6.6	11	53	16	18	12.0	25	9.0	5.5	42	15	38.0	M6x18	0.28	F _{max} EMC
50	R349947100 ¹⁾	16	9.0	15	65	21	20	15.0	27	10.5	6.5	48	19	46.5	M8x20	0.43	F _{max} EMC
63	R349947200 ¹⁾	16	9.0	15	75	21	23	15.0	32	10.5	6.5	55	21	56.5	M8x20	0.68	14 500
80	R349947300 ¹⁾	20	11.0	18	95	25	27	18.0	36	14.0	10.0	70	24	72.0	M10x20	1.21	17 800
100	R349947400 ¹⁾	20	11.0	18	115	25	30	18.0	41	15.0	10.0	80	25	89.0	M10x20	2.03	22 900
100XC	1827001626 ²⁾	35	18.0	26	176	43	44	30.0	55	17.0	10.0	130	39	140.0	M16x30	6.10	F _{max} EMC

¹⁾ Material: Aluminum

²⁾ Material: Galvanized cast iron with spheroidal graphite

Fastening elements

Swivel bearing, high

Material: Galvanized cast iron with spheroidal graphite. Without fastening screws

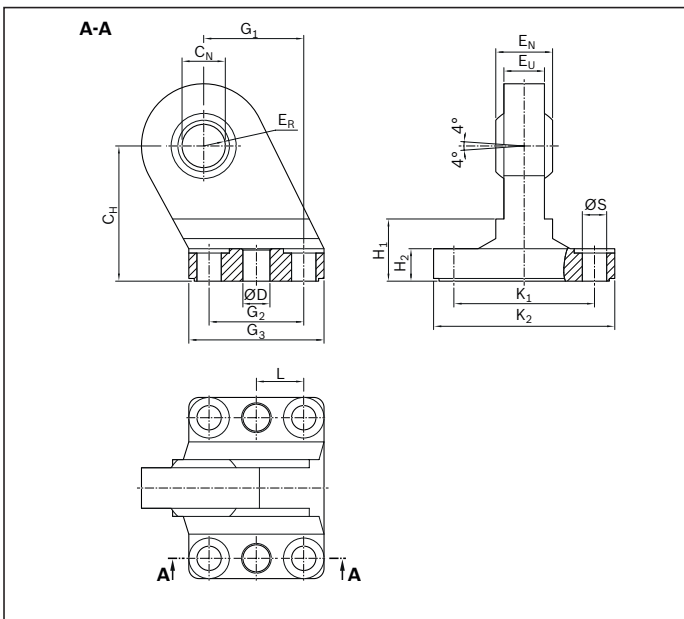
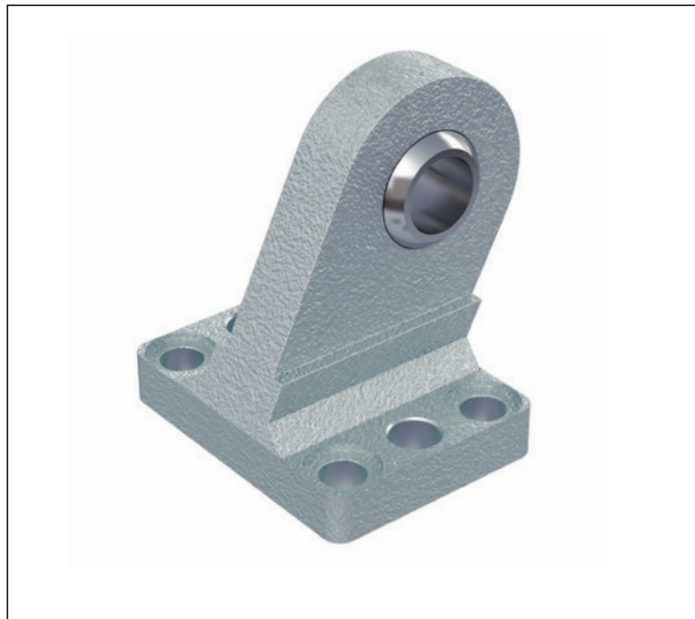
Group 6
Option 03

EMC	Material number	Dimensions (mm)															m (kg)
		CH JS15	CN H7	ØD H11	EN -1.0	ER max.	EU	G1 JS14	G2 JS14	G3 max.	H1	H2	K1 JS14	K2 max.	L ±0.2	ØS H13	
32	R349946300	32	10	-	14	16	10.5	21	18	31	16	9 ^{±1.0}	38	51	-	6.6	0.21
40	R349946400	36	12	-	16	18	12.0	24	22	35	16	9 ^{±1.0}	41	54	-	6.6	0.27
50	R349946500	45	16	-	21	21	15.0	33	30	45	23	11 ^{±1.0}	50	65	-	9.0	0.50
63	R15614A018	50	16	10	21	23	15.0	37	35	50	23	11 ^{±1.0}	52	67	17.5	9.0	0.61
80	R15615A018	63	20	10	25	28	18.0	47	40	60	32	12 ^{±1.5}	66	86	20.0	11.0	1.14
100	R15616A018	71	20	10	25	30	18.0	55	50	70	33	13 ^{±1.5}	76	96	25.0	11.0	1.56
100XC	R15617A018	115	35	12	43	44	28.0	97	88	126	70	17 ^{±1.5}	118	156	44.0	14.0	6.64

Clevis mount with force measuring bolt

Group 1
Option 02 Group 5
Option 10

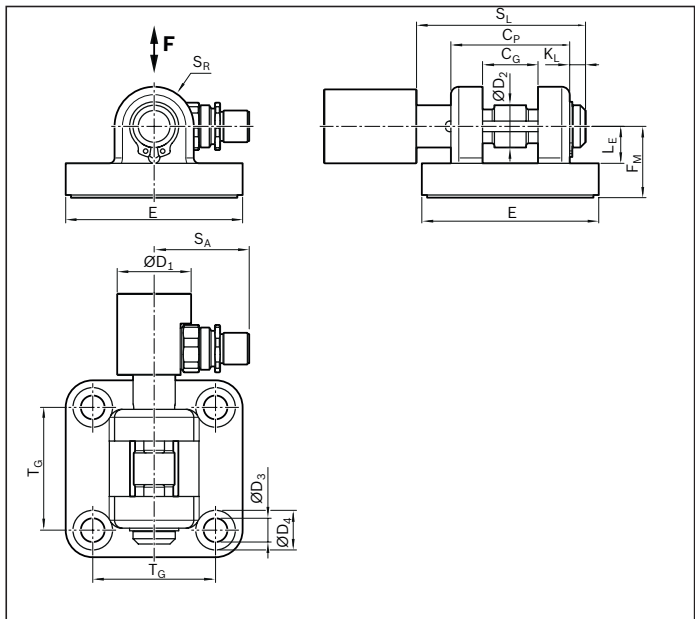

EMC	Material number	Dimensions (mm)															m (kg)	F _{max} (N)	
		C _G D10	C _P d12	ØD ₁	ØD ₂ f8	ØD ₃	ØD ₄	E	F _M ±0.2	K _L	L _E min.	S _A	S _L	S _R	T ±0.2	T _G ±0.2			DIN 912
32	R15611B021 ¹⁾	14	34	28	10	6.6	11	49	22	4.5	11.5	31.5	48	11	3	32.5	M6x18	0.372	F _{max EMC}
40	R15612B021 ¹⁾	16	40	28	12	6.6	11	55	25	4.5	12.0	31.5	54	12	4	38.0	M6x18	0.485	F _{max EMC}
50	R15613B021 ¹⁾	21	45	28	16	9.0	15	67	27	6.0	14.0	31.5	64	15	4	46.5	M8x20	0.721	F _{max EMC}
63	R15614B021 ¹⁾	21	51	28	16	9.0	15	77	32	6.0	14.0	31.5	72	15	4	56.5	M8x20	1.025	14 500
80	R15615B021 ¹⁾	25	65	28	20	11.0	18	97	36	6.5	16.0	31.5	74	20	4	72.0	M10x20	1.829	17 800
100	R15616B021 ¹⁾	25	75	28	20	11.0	18	117	41	6.5	16.0	31.5	84	20	4	89.0	M10x20	2.866	22 900
100XC	R15617B021 ²⁾	43	122	35	35	18.0	26	180	55	10.5	35.0	35.5	135	26	6	140.0	M16x50	2.994	F _{max EMC}

¹⁾ Material: Aluminum (forged)

²⁾ Material: Galvanized spheroidal graphite iron

Instruction for mounting

Pay attention to the direction of force, see also force sensor

Fastening elements

Swivel mount for force measuring bolt

Material: Aluminum

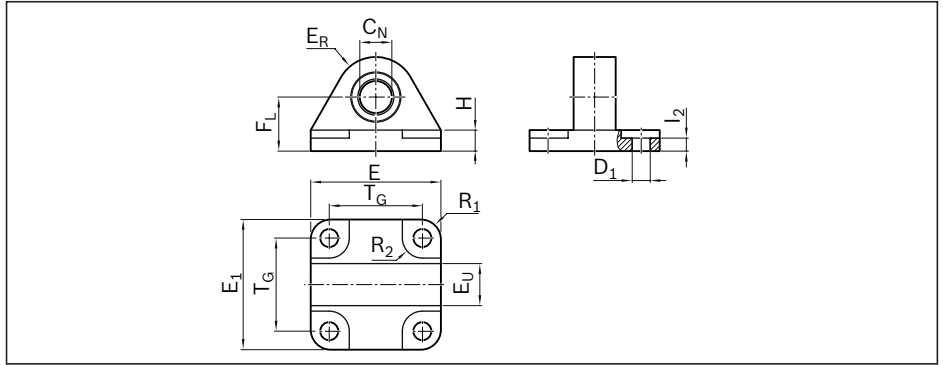
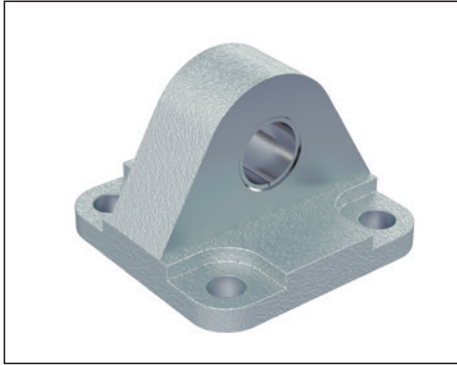
Group 6
Option 05

EMC	Material number	Dimensions (mm)											m (kg)
		$\varnothing C_N$ H7	$\varnothing D_1$ H13	F_L ± 0.2	H ± 0.5	E_R ± 0.2	E_U ± 0.2	l_2 ± 0.5	E/E_1 ± 0.5	T_G	R_1/R_2	DIN 912	
32	R15611B025	10	6.6	22	9.0	15	14	5.5	47	32.5	8	M6x18	0.074
40	R15612B025	12	6.6	25	9.0	18	16	5.5	53	38.0	8	M6x18	0.109
50	R15613B025	16	9.0	27	10.5	20	21	6.5	65	46.5	10	M8x20	0.181
63	R15614B025	16	9.0	32	10.5	23	21	6.5	80	56.5	10	M8x20	0.257
80	R15615B025	20	11.0	36	14.0	27	25	10.0	95	72.0	13	M10x20	0.493
100	R15616B025	20	11.0	41	15.0	30	25	10.0	115	89.0	13	M10x20	0.747
100XC	R15617B025	35	18.0	55	17.0	44	43	10.0	176	140.0	20	M16x40	2.238

Accessories

Screw plug for cover

Material: corrosion-resistant

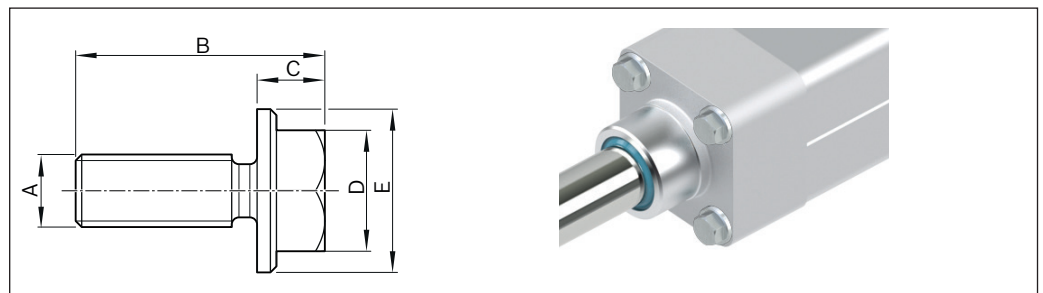
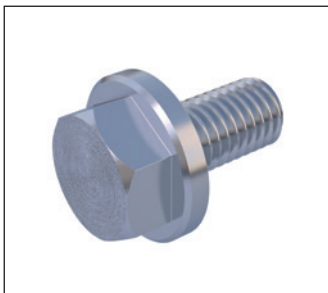

EMC	Material number	Dimensions (mm)				
		A	B	C	D	E
32/40	R15610A015	M6	20.6	5.6	SW 10	13.5
50/63	R15610A016	M8	24.0	8.0	SW 13	18.0
80/100	R15610A017	M10	29.0	8.5	SW 16	22.0
100XC	R15610A018	M12	36.0	10.0	SW 18	25.0

Accessories

Connection for central lubrication system

Is supplied once as part of the delivery if the lubrication option LCF has been chosen (prepared for central lubrication system for liquid grease).

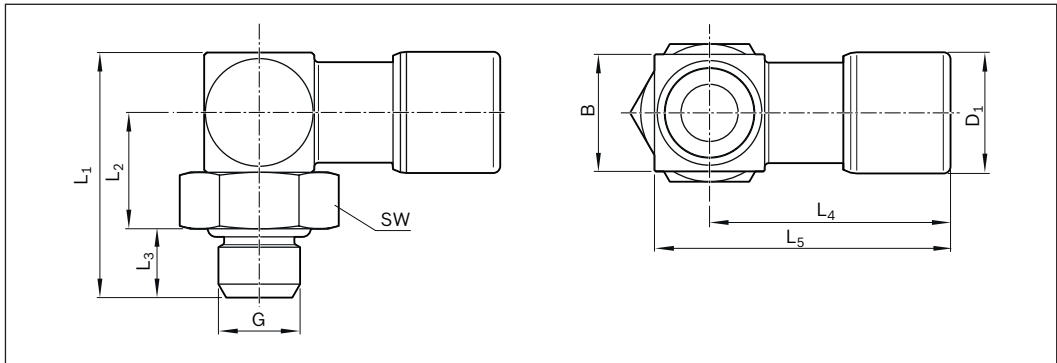

Material number	Material	G	for tubing	Dimensions (mm)								m (g)
				SW	L ₁	L ₂	L ₃	L ₄	L ₅	B	D ₁	
R913031697	Nickel-plated brass (for housing option standard and IP65)	M6	AD4(4/2)	10	17.8	8.5	5	17.5	21.5	8.5	8.8	10
R913031717	Corrosion-resistant steel 1.430/1.4307 (for housing option IP65+R)											

Features

- Enclosed O-ring
- Temperature range -20 to +120 °C
- Seals FPM
- Operating pressure range -0.95 to 24 bar

Instruction for mounting

In order to connect the EMC to a central lubrication system, remove the standard lube nipple from the housing and replace it with the port for the central lubrication system.

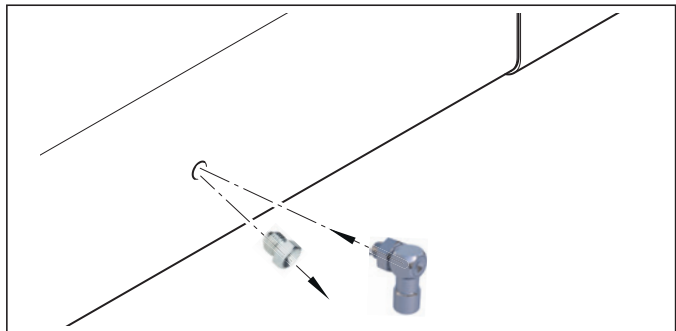

Force sensor

Force measuring bolt



Clevis mount with force measuring bolt

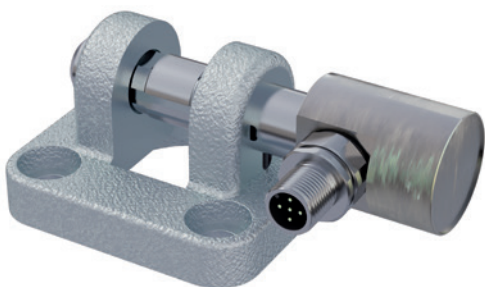

If your application requires precise load sensing, there is a clevis bearing block version with force measuring bolt available for this purpose. This option can be selected both at the piston rod end connected to the spherical rod end bearing, and at the belt side drive.

Thanks to the thin-film technology used, the load cells are very robust and stable over the long term. The load cells are compliant with the EN 61326 standard for electromagnetic compatibility (EMC) and are designed to sense both tensile and compressive forces.

Note

The use of a hammer or press to fit the bolt is not permissible. It may only be inserted by hand.

The bolt is not suitable to handle torques. It is secured axially and against rotation, like the standard bolt, on one side of the clevis mount using the included retaining ring and clamping pin.

For force control at the controller level, a control component with an analog input is required.

Output signal 4 - 20 mA, reduced measurement range and test certificate on request.

Technical data, force measuring bolts

Metrological specifications

Material	Stainless steel
Enclosure protection class	IP65
Hardness (load range)	38 HRC
Mechanical system	
Operating load	150% of MB
Breaking load	300% of MB
Accuracy	
Non-linearity	±0.5% of MB
Repeatability	±0.25% of MB
Hysteresis	±0.2% of MB
Temperature drift at zero point	±0.05% of MB/K.
Temperature drift over measurement range	±0.05% of MB/K.
Compensated temperature	+10 ... +40 °C
Operating temperature	-20 ... +60 °C

Electrical specifications

Output signal	OkN	0±0.03 V
Output signal	MB	-10 ... 10 V ±0.2 V
Power supply voltage		24 V ±2 V
Tare (zero setting function)		7.2 ... 24 V
Current consumption		25 mA (24 V)
Bandwidth		2.5 ±0.2 KHz
Connection		Plug M12x1

Technical data, connection cable

Length	5 m
Rated voltage	250 V
Rated current	4 A
Plug outlet	angled
Connection type 1	Female connector, M12, 4-pin
Connection type 2	Flying leads
Type of cable	PUR black, shielded
Suitable for drag chains	yes
Cable cross-section	4x0.34 mm ²
Cable diameter D	5.9 ±0.2 mm
Static bending radius	>10xD
Dynamic bending radius	>5xD
Bending cycles	> 2 Mio
Ambient temperature, stationary	-25 ... +80 °C
Ambient temperature, in motion	-40 ... +80 °C
Enclosure protection class	IP65

Connection cable in the scope of delivery

MB = Measurement range
MB/K. = Measurement range per Kelvin

Features

- ▶ For tensile and compressive forces
- ▶ Corrosion-resistant
Stainless steel version
- ▶ Integrated amplifier
- ▶ Low temperature coefficient
- ▶ High long term stability
- ▶ High shock and vibration resistance
- ▶ For dynamic or static measurements
- ▶ Good reproducibility
- ▶ Easy mounting

Dimensions/material numbers

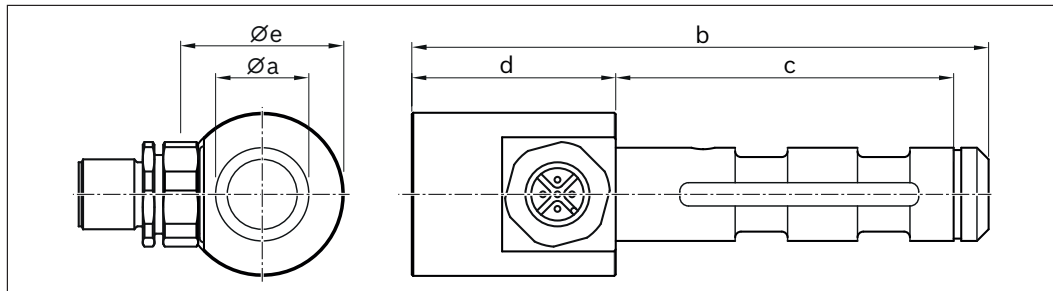

EMC	Material number (force measuring bolt) ¹⁾	Dimensions (mm)					Measurement range (kN)	Measurement inaccuracy (kN)
		Øa _{FB}	b	c	d	Øe		
32	R15611A007	10	83	43.5	35	28	1.3	± 0.007
40	R15612A007	12	89	49.5	35	28	5.0	± 0.025
50	R15613A007	16	99	58.0	35	28	8.0	± 0.04
63	R15614A007	16	107	66.0	35	28	16.0	± 0.08
80	R15615A007	20	109	67.5	35	28	22.0	± 0.11
100	R15616A007	20	119	77.5	35	28	45.0	± 0.23
100XC	R15617A007	35	170	124.5	35	35	56.0	± 0.28

¹⁾ with connection cable

Connection diagram

Force measuring bolt

- 1 Supply (+)
- 2 Tare
- 3 GND
- 4 Output
- 5 Internal assignment

Connection cable

- 1 brn = brown, supply (+)
- 2 wht = white, tare
- 3 blu = blue, GND
- 4 blk = black, output

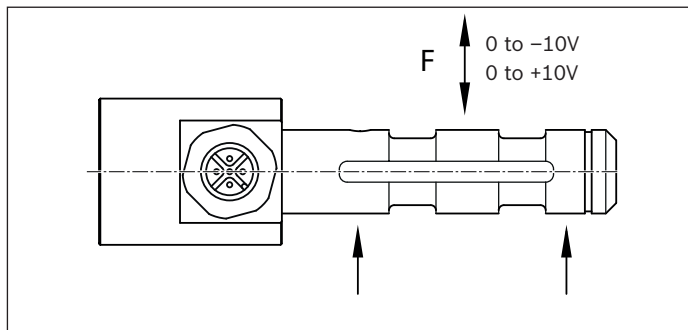

Output signal depending on direction of loading

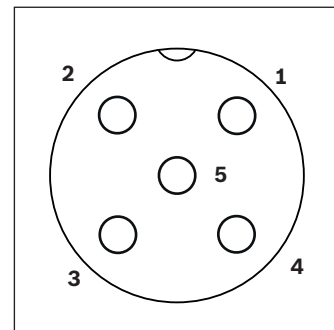

Connection diagram for measuring bolt

Switching system

Sensor profile

- 1 Retaining bracket
- 2 Sensor profile
- 3 Slot for sensor profile (opposite the lube nipple)
- 4 Lube nipple

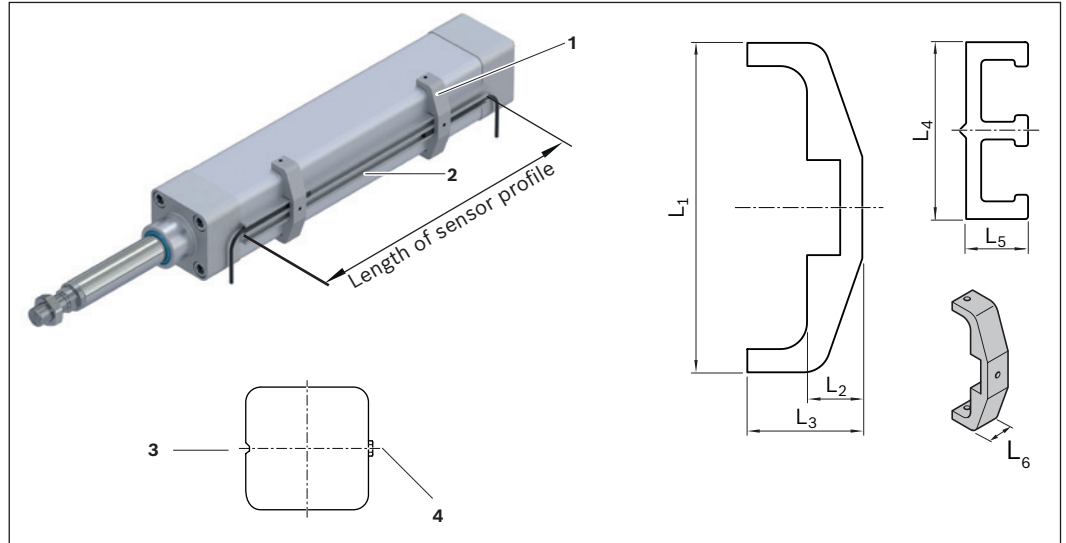

EMC	Material number		BASA size d ₀ x P (mm)	Dimensions (mm)						
	Retaining bracket	Sensor profile		L _{SL}	L ₁	L ₂	L ₃	L ₄	L ₅	L ₆
32	R15611B022	R15610A009	12 x 5	68	56.5	12.5	25	20	7	15
			12 x 10	72						
40	R15612B022		16 x 5	67	62.5	12.5	25			
			16 x 10	76						
			16 x 16	92						
50	R15613B022		20 x 5	62	74.5	12.5	26			
			20 x 10	81						
			20 x 20	100						
63	R15614B022		25 x 5	66	84.5	12.5	26			
			25 x 10	85						
			25 x 25	117						
80	R15615B022		32 x 5	70	104.5	12.5	26			
			32 x 10	94						
			32 x 20	102						
		32 x 32	137							
100	R15616B022	40 x 5	68	124.0	12.5	31				
		40 x 10	82							
		40 x 20	100							
		40 x 40	155							
100XC	R15616B022	50 x 10	129	124.0	12.5	31				
		50 x 20	151							

Number of retaining brackets

Length of sensor profile (mm)	Number of retaining brackets
≤500	2
≤900	3
≤1 200	4
≤1 500	5

Length calculation Sensor profile

Length of sensor profile = s_{max} + L_{SL}

s_{max} = Maximum travel range (mm)

Switching system

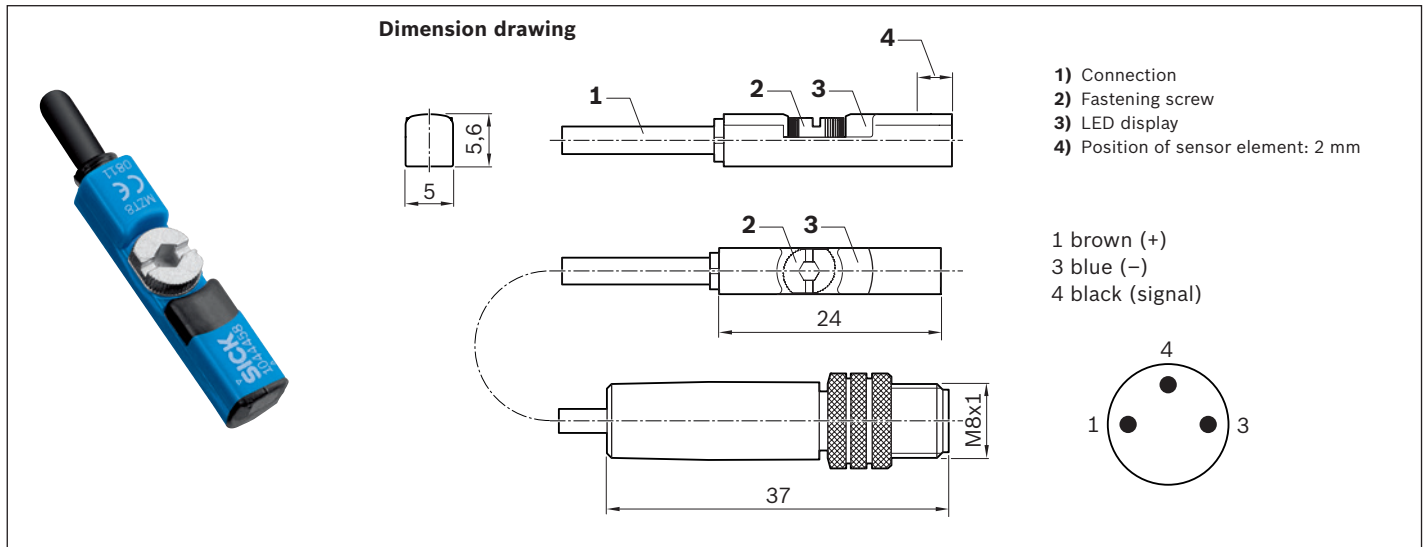

Magnetic switches

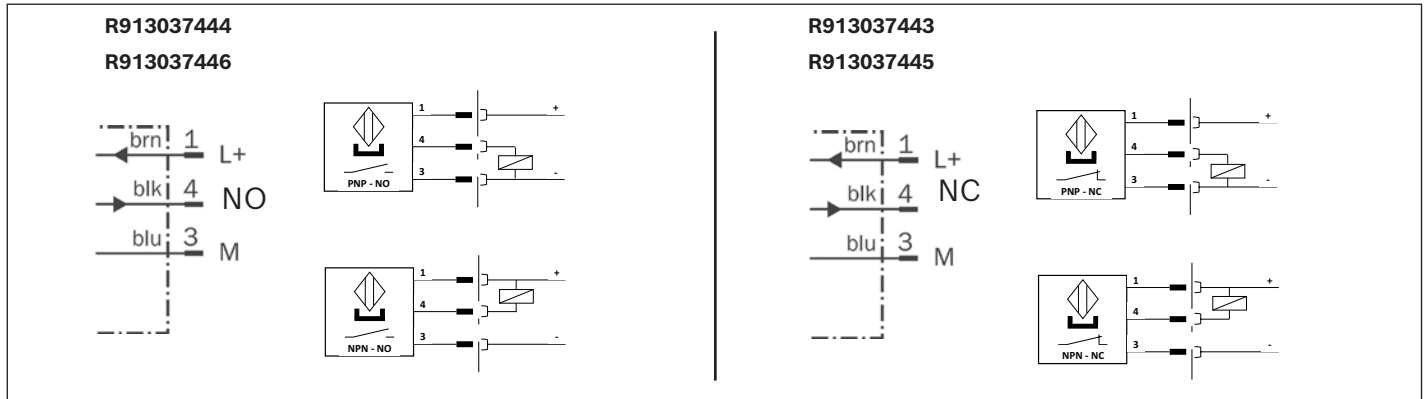

Connection diagram



Material numbers/technical data

Use	Limit switch	Reference switch	Limit switch	Reference switch
Material number	R913037445	R913037444	R913037443	R913037446
Name	MZT8-03VPO-KRDS14	MZT8-03VPS-KRDS13	MZT8-03VNO-KRDS16	MZT8-03VNS-KRDS15
Functional principle	magnetic			
Operating voltage	10 - 30 VDC			
Load current	≤ 200 mA			
Switching function	PNP/NC	PNP/NO	NPN/NC	NPN/NO
Connection type	0.5 m cable and M8x1 plug, 3-pin with knurled screw connection			
Function indicator	✓			
Short-circuit protection	✓			
Reverse polarity protection	✓			
Switch-on suppression	✓			
Switching frequency	3 kHz			
Pulse elongation (off delay)	20 ms			
Max. permissible starting speed	5 m/s			
Suitable for drag chains*	✓			
Torsion-resistant*	✓			
Welding spark-resistant*	—			
Cable cross-section*	3x0.14 mm ²			
Cable diameter D*	2.9 ±0.15 mm			
Static bending radius*	≥ 5xD			
Dynamic bending radius*	≥ 10xD			
Bending cycles*	> 2 Mio.			
Max. permissible travel speed*	5 m/s			
Max. permissible acceleration*	≤ 5 m/s ²			
Ambient temperature	-30 °C to +80 °C			
Enclosure protection class	IP68			
MTTFd (per EN ISO 13849-1)	MTTFd = 2,339.0 years			
Certifications and approvals**	  			

*) Technical data for connection line (0.5 m) cast on magnetic sensor only. Available extension cables offer even more performance, e.g. for use in a cable drag chain (see below).

** No  certificate for import to the Chinese market required for these products. Document "Sales information CCC" available on request.

Switching system

Extensions

Assembled on one end

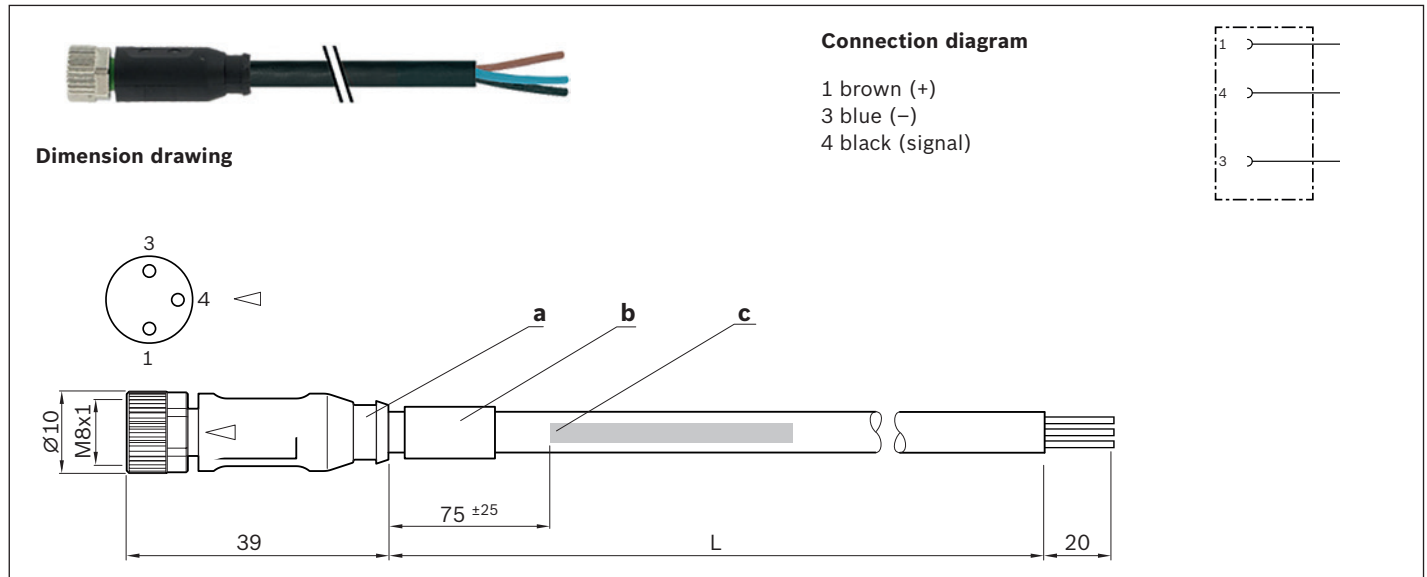

Material numbers



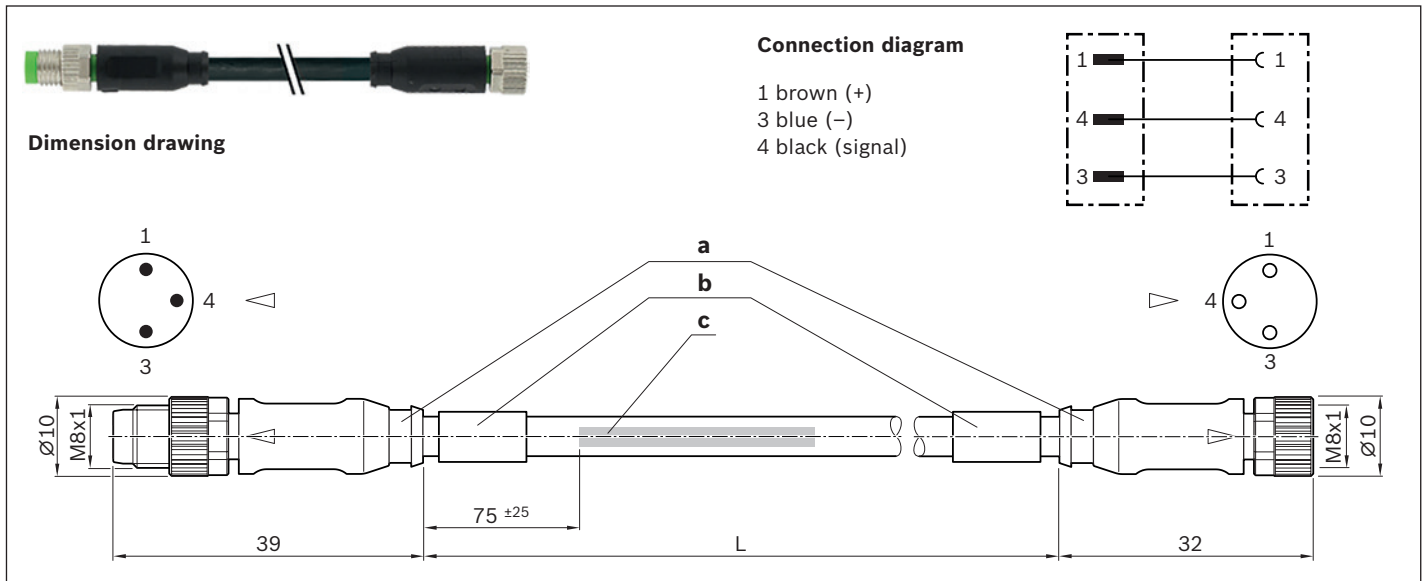

Use	Extension cable		
Material number	R911344602	R911344619	R911344620
Name	7000-08041-6500500	7000-08041-6501000	7000-08041-6501500
Length (L)	5.0 m	10.0 m	15.0 m
Connection type 1	Female connector, straight, M8x1, 3-pin		
Connection type 2	Unassembled cable end		

- a) Contour for 6.5 mm corrugated tube (inner diameter)
- b) Cable grommet
- c) Cable printing per printing specification

Assembled on two sides

Material numbers

Use	Extension cable				
Material number	R911344621	R911344622	R911344623	R911344624	R911344625
Name	7000-88001-6500050	7000-88001-6500100	7000-88001-6500200	7000-88001-6500500	7000-88001-6501000
Length (L)	0.5 m	1.0 m	2.0 m	5.0	10.0
Connection type 1	Female connector, straight, M8x1, 3-pin				
Connection type 2	Plug, straight, M8x1, 3-pin				

Technical data for extensions pre-assembled on one or two sides

Function indicator	-
Operating voltage indicator	-
Operating voltage	10 - 30 VDC
Type of cable	PUR black
Suitable for drag chains	✓
Torsion-resistant	✓
Weld spark-resistant	✓
Cable cross-section	3x0.25 mm ²
Cable diameter D	4.1 ±0.2 mm
Static bending radius	≥ 5xD
Dynamic bending radius	≥ 10xD
Bending cycles	> 10 Mio.
Max. permissible travel speed	3.3 m/s for 5 m travel range (typ.), up to 5 m/s for 0.9 m travel range
Max. permissible acceleration	≤ 30 m/s ²
Ambient temperature fixed ext.	-40 °C to +85 °C
Ambient temperature flexible ext.	-25 °C to +85 °C
Enclosure protection class	IP68
Certifications and approvals	    



- a) Contour for 6.5 mm corrugated tube (inner diameter)
 b) Cable grommet
 c) Cable printing per printing specification

Switching system

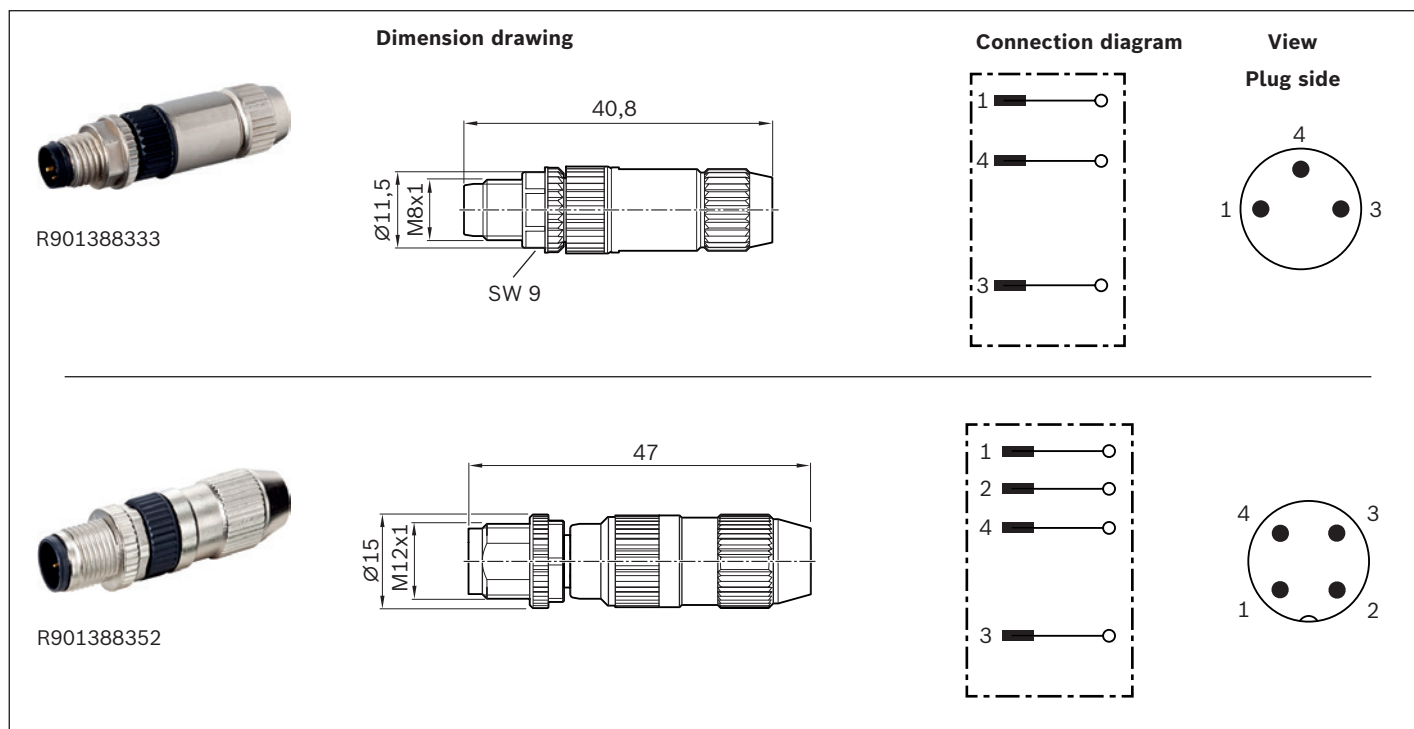

Plugs





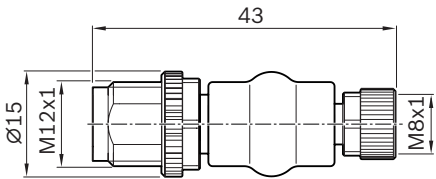

Material numbers / technical data

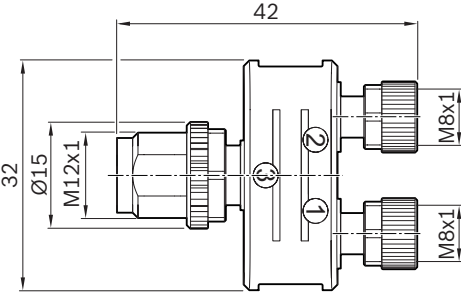
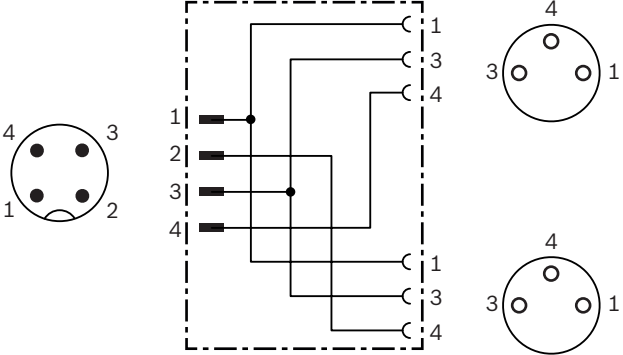
Use	Plug, single	
Material number	R901388333	R901388352
Name	7000-08331-0000000	7000-12491-0000000
Version	straight	
Operating current per contact	max. 4 A	
Operating voltage	max. 32 V AC/DC	
Connection type	Plug, straight, M8x1, 3-pin Insulation displacement, self-locking screw thread	Plug, straight, M12x1, 4-pin Insulation displacement, self-locking screw thread
Function indicator	-	
Operating voltage indicator	-	
Connection cross-section	0.14...0.34 mm ²	
Ambient temperature	-25 °C to +85 °C	
Enclosure protection class	IP67 (inserted and locked)	
Certifications and approvals	  	

Adapters

	Dimension drawing	Connection diagram
 R911344591		
 R911344592		

Material numbers / technical data

Use	Adapters	
Material number	R911344591	R911344592
Name	7000-42201-0000000	7000-41211-0000000
Version	straight	
Operating current per contact	max. 4 A	
Operating voltage	max. 32 V AC/DC	
Connection type 1	Female connector, straight, M8x1, 3-pin self-locking screw thread	2 X Female connector, straight, M8x1, 3-pin self-locking screw thread
Connection type 2	Plug, straight, M12x1, 3-pin, self-locking screw thread	Plug, straight, M12x1, 4-pin self-locking screw thread
Function indicator	-	
Operating voltage indicator	-	
Connection cross-section	-	
Ambient temperature	-25 °C to +85 °C	
Enclosure protection class	IP67 (inserted and locked)	
Certifications and approvals		  

IndraDyn S – servo motors MSM

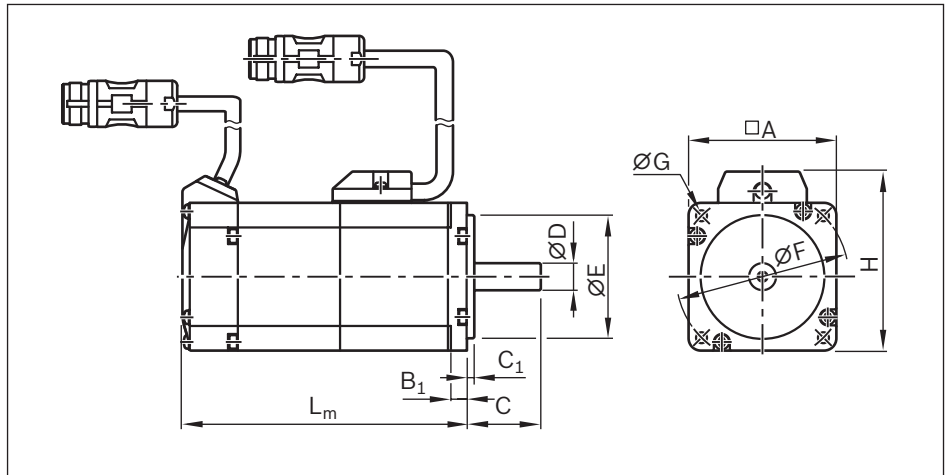

Motor schematic

Motor code	Dimensions (mm)										
	A	B ₁	C	C ₁	∅ D h6	∅ E h7	∅ F	∅ G	Brake		L _m
									without	with	
MSM 019B-0300	38	6.0	25	3	8	30	45	3.4	92.0	122.0	
MSM 031B-0300	60	6.5	30	3	11	50	70	4.5	79.0	115.5	
MSM 031C-0300	60	6.5	30	3	14	50	70	4.5	98.5	135.0	
MSM 041B-0300	80	6.0	35	3	19	70	90	6.0	112.0	149.0	

Version:

- ▶ Plain shaft without shaft seal
- ▶ M5 multi-turn absolute encoder (20-bit, absolute encoder function only available with backup battery)
- ▶ Cooling system: natural convection
- ▶ IP54 enclosure protection class (shaft: IP40)
- ▶ With and without brake
- ▶ M17 metal round connector

Note

Motors are available with control units and controllers. You can find more information on motors and controllers in the Rexroth catalogs on drive technology at www.boschrexroth.com/medienverzeichnis.

Motor data									Motor connection	Brake	Type code	Material number
n_{max} (min^{-1})	M_0 (Nm)	M_{max} (Nm)	M_{br} (Nm)	J_m (kgm^2)	J_{br} (kgm^2)	m_m (kg)	m_{br} (kg)					
5 000	0.32	0.95	0.29	0.0000051	0.0000002	0.47	0.21	2	N	MSM 019B-0300-NN-M5-MH0	R911344211	
									Y	MSM 019B-0300-NN-M5-MH1	R911344212	
5 000	0.64	1.91	1.27	0.0000140	0.0000018	0.82	0.48	2	N	MSM 031B-0300-NN-M5-MH0	R911344213	
									Y	MSM 031B-0300-NN-M5-MH1	R911344214	
5 000	1.30	3.80	1.27	0.0000260	0.0000018	1.20	0.50	2	N	MSM 031C-0300-NN-M5-MH0	R911344215	
									Y	MSM 031C-0300-NN-M5-MH1	R911344216	
4 500	2.40	7.10	2.45	0.0000870	0.0000075	2.30	0.80	2	N	MSM 041B-0300-NN-M5-MH0	R911344217	
									Y	MSM 041B-0300-NN-M5-MH1	R911344218	

Recommended motor-controller combination



Motor	Controller
MSM 019B-0300	HCS 01.1E-W0003
MSM 031B-0300	HCS 01.1E-W0006
MSM 031C-0300	HCS 01.1E-W0009
MSM 041B-0300	HCS 01.1E-W0013

Motor characteristic

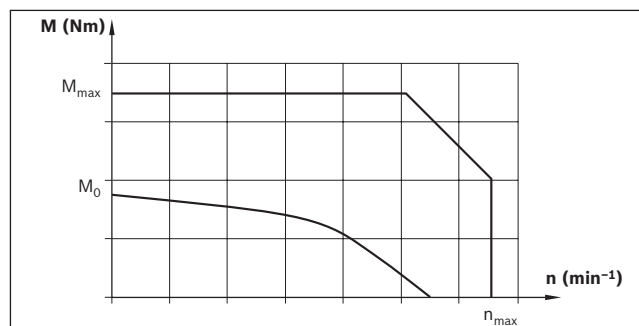
(schematic)

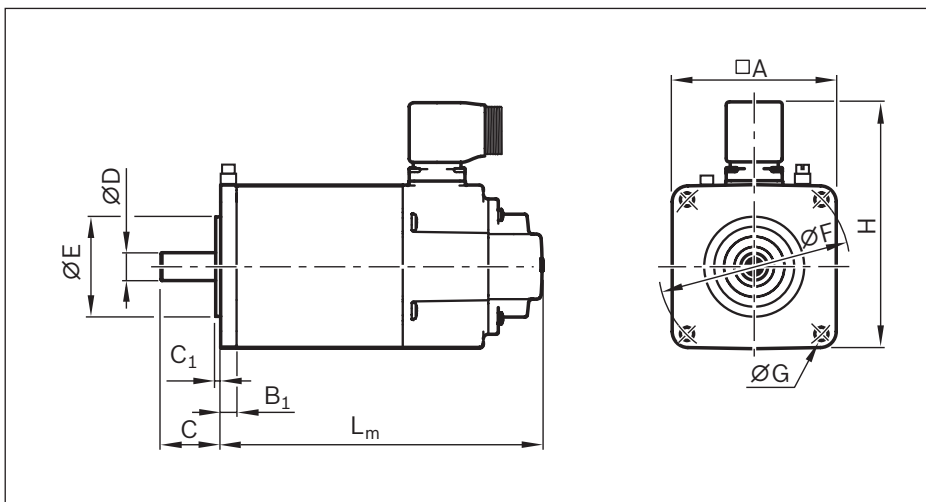
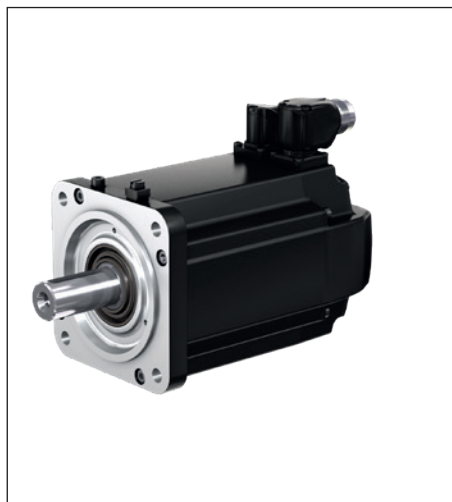

IndraDyn S – servo motors MS2N



Motor schematic

Dimensions / motor data

Motor code	Dimensions (mm)											
	□ A	B ₁	C	C ₁	Ø D k6	Ø E j7	Ø F	Ø G	Cables 2	1	H Brake without	L _m with
MS2N03-B0BYN	58	7.5	20	2.5	9	40	63	4.5	84	99	163	192
MS2N03-D0BYN	58	7.5	23	2.5	11	40	63	4.5	84	99	203	232
MS2N04-B0BTN	82	8	30	2.5	14	50	95	6.6	108	123	162	194.5
MS2N04-C0BTN	82	8	30	2.5	14	50	95	6.6	108	123	194	226.5
MS2N04-D0BQN	82	8	30	2.5	14	50	95	6.6	108	123	226	258.5
MS2N05-B0BTN	98	9	40	3	19	95	115	9	124	139	188	218
MS2N05-C0BTN	98	9	40	3	19	95	115	9	124	139	224	254
MS2N05-D0BRN	98	9	40	3	19	95	115	9	124	139	260	290

Version

- ▶ Plain shaft without shaft seal ring
- ▶ Multi-turn encoder
- ▶ Standard encoder (B) in conjunction with 2-cable connection (Hiperface interface)
- ▶ Advanced encoder (C) in conjunction with 1-cable connection (AcuroLink interface)
- ▶ IP64 enclosure protection class
- ▶ With and without brake
- ▶ Special ground connection terminal near motor flange (used as needed)

Notes:

Motors are available with control units and controllers. You can find more information on motors and controllers in the Rexroth catalogs on drive technology at www.boschrexroth.com/medienverzeichnis.

Motor data									Motor connection	Brake	Type code	Material number
n_{max} (min ⁻¹)	M_0 (Nm)	M_{max} (Nm)	M_{br} (Nm)	J_m (kgm ²)	J_{br} (kgm ²)	m_m (kg)	m_{br} (kg)					
9 000	0.73	3.46	1.8	0.000023	0.000007	2.0	0.4	2	N	MS2N03-B0BYN-BMDH0-NNNNE-NN	R911384765	
								2	Y	MS2N03-B0BYN-BMDH1-NNNNE-NN	R911384766	
								1	N	MS2N03-B0BYN-CMSH0-NNNNE-NN	R911384767	
								1	Y	MS2N03-B0BYN-CMSH1-NNNNE-NN	R911384769	
9 000	1.15	6.8	1.8	0.000037	0.000007	2.0	0.4	2	N	MS2N03-D0BYN-BMDH0-NNNNE-NN	R911384770	
								2	Y	MS2N03-D0BYN-BMDH1-NNNNE-NN	R911384771	
								1	N	MS2N03-D0BYN-CMSH0-NNNNE-NN	R911384772	
								1	Y	MS2N03-D0BYN-CMSH1-NNNNE-NN	R911384773	
6 000	1.75	5.9	5.0	0.000070	0.000040	2.7	0.7	2	N	MS2N04-B0BTN-BMDH0-NNNNE-NN	R911384525	
								2	Y	MS2N04-B0BTN-BMDH1-NNNNE-NN	R911384526	
								1	N	MS2N04-B0BTN-CMSH0-NNNNE-NN	R911384527	
								1	Y	MS2N04-B0BTN-CMSH1-NNNNE-NN	R911384528	
6 000	2.80	12.0	5.0	0.000110	0.000050	3.7	0.7	2	N	MS2N04-C0BTN-BMDH0-NNNNE-NN	R911384529	
								2	Y	MS2N04-C0BTN-BMDH1-NNNNE-NN	R911384530	
								1	N	MS2N04-C0BTN-CMSH0-NNNNE-NN	R911384531	
								1	Y	MS2N04-C0BTN-CMSH1-NNNNE-NN	R911384532	
6 000	3.85	18.1	5.0	0.000160	0.000040	4.7	0.7	2	N	MS2N04-D0BQN-BMDH0-NNNNE-NN	R911384533	
								2	Y	MS2N04-D0BQN-BMDH1-NNNNE-NN	R911384534	
								1	N	MS2N04-D0BQN-CMSH0-NNNNE-NN	R911384535	
								1	Y	MS2N04-D0BQN-CMSH1-NNNNE-NN	R911384536	
6 000	3.75	10.6	10.0	0.000170	0.000110	4.0	1.1	2	N	MS2N05-B0BTN-BMDH0-NNNNE-NN	R911384539	
								2	Y	MS2N05-B0BTN-BMDH1-NNNNE-NN	R911384540	
								1	N	MS2N05-B0BTN-CMSH0-NNNNE-NN	R911384542	
								1	Y	MS2N05-B0BTN-CMSH1-NNNNE-NN	R911384543	
6 000	6.10	20.8	10.0	0.000290	0.000110	5.9	1.1	2	N	MS2N05-C0BTN-BMDH0-NNNNE-NN	R911384544	
								2	Y	MS2N05-C0BTN-BMDH1-NNNNE-NN	R911384545	
								1	N	MS2N05-C0BTN-CMSH0-NNNNE-NN	R911384546	
								1	Y	MS2N05-C0BTN-CMSH1-NNNNE-NN	R911384547	
6 000	7.90	31.3	10.0	0.000400	0.000110	7.3	1.1	2	N	MS2N05-D0BRN-BMDH0-NNNNE-NN	R911384548	
								2	Y	MS2N05-D0BRN-BMDH1-NNNNE-NN	R911384549	
								1	N	MS2N05-D0BRN-CMSH0-NNNNE-NN	R911384550	
								1	Y	MS2N05-D0BRN-CMSH1-NNNNE-NN	R911384551	

IndraDyn S – servo motors MS2N

Dimensions / motor data

Motor code	Dimensions (mm)												
	A	B ₁	C	C ₁	∅ D k6	∅ E j7	∅ F	∅ G	Cables 2	1	H Brake without	with	L _m
MS2N06-C0BTN	116	14	50	3	24	95	130	9	156	156	184	202	
MS2N06-D0BRN	116	14	50	3	24	95	130	9	156	156	224	261	
MS2N06-D1BNN	116	14	50	3	24	95	130	9	156	156	224	261	
MS2N06-E0BRN	116	14	50	3	24	95	130	9	156	156	264	301	
MS2N07-B1BNN	140	18	58	4	32	130	165	11	180	180	176	230	
MS2N07-C0BQN	140	18	58	4	32	130	165	11	180	180	205	259	
MS2N07-C1BRN	140	18	58	4	32	130	165	11	180	180	205	259	
MS2N07-D0BRN	140	18	58	4	32	130	165	11	180	180	263	317	
MS2N07-D1BNN	140	18	58	4	32	130	165	11	180	180	263	317	
MS2N07-E0BQN	140	18	58	4	32	130	165	11	180	180	321	375	
MS2N07-E1BNN	140	18	58	4	32	130	165	11	180	180	321	375	
MS2N10-C0BNN	196	20	80	4	38	180	215	14	270	270	238	298	
MS2N10-D0BNN	196	20	80	4	38	180	215	14	270	270	296	356	
MS2N10-E0BNN	196	20	80	4	38	180	215	14	270	270	354	414	

Motor data									Motor connection	Brake	Type code	Material number
n_{max} (min^{-1})	M_0 (Nm)	M_{max} (Nm)	M_{br} (Nm)	J_m (kgm^2)	J_{br} (kgm^2)	m_m (kg)	m_{br} (kg)					
6 000	6.00	16.0	10.0	0.000390	0.000110	6.4	1.0	2	N	MS2N06-C0BTN-BMUH0-NNNNE-NN	R911384931	
								2	Y	MS2N06-C0BTN-BMUH1-NNNNE-NN	R911384932	
								1	N	MS2N06-C0BTN-CMSH0-NNNNE-NN	R911384933	
								1	Y	MS2N06-C0BTN-CMSH1-NNNNE-NN	R911384934	
6 000	9.70	32.0	15.0	0.000650	0.000140	9.0	1.5	2	N	MS2N06-D0BRN-BMUH0-NNNNE-NN	R911384935	
								2	Y	MS2N06-D0BRN-BMUH2-NNNNE-NN	R911384936	
								1	N	MS2N06-D0BRN-CMSH0-NNNNE-NN	R911384937	
								1	Y	MS2N06-D0BRN-CMSH2-NNNNE-NN	R911384938	
6 000	9.00	38.4	15.0	0.001400	0.000140	9.0	1.5	2	N	MS2N06-D1BNN-BMUH0-NNNNE-NN	R911384939	
								2	Y	MS2N06-D1BNN-BMUH2-NNNNE-NN	R911384940	
								1	N	MS2N06-D1BNN-CMSH0-NNNNE-NN	R911384941	
								1	Y	MS2N06-D1BNN-CMSH2-NNNNE-NN	R911384942	
6 000	13.0	49.0	15.0	0.000890	0.000140	11.5	1.5	2	N	MS2N06-E0BRN-BMUH0-NNNNE-NN	R911384943	
								2	Y	MS2N06-E0BRN-BMUH2-NNNNE-NN	R911384944	
								1	N	MS2N06-E0BRN-CMSH0-NNNNE-NN	R911384945	
								1	Y	MS2N06-E0BRN-CMSH2-NNNNE-NN	R911384946	
6 000	7.40	21.0	20.0	0.001970	0.000260	9.5	2.0	2	N	MS2N07-B1BNN-BMUH0-NNNNE-NN	R911384949	
								2	Y	MS2N07-B1BNN-BMUH1-NNNNE-NN	R911384950	
								1	N	MS2N07-B1BNN-CMSH0-NNNNE-NN	R911384951	
								1	Y	MS2N07-B1BNN-CMSH1-NNNNE-NN	R911384952	
6 000	12.8	35.7	20.0	0.001200	0.000260	12.0	2.0	2	N	MS2N07-C0BQN-BMUH0-NNNNE-NN	R911384953	
								2	Y	MS2N07-C0BQN-BMUH1-NNNNE-NN	R911384954	
								1	N	MS2N07-C0BQN-CMSH0-NNNNE-NN	R911384955	
								1	Y	MS2N07-C0BQN-CMSH1-NNNNE-NN	R911384956	
6 000	11.50	42.2	20.0	0.003050	0.000260	12.0	2.0	2	N	MS2N07-C1BRN-BMUH0-NNNNE-NN	R911384957	
								2	Y	MS2N07-C1BRN-BMUH1-NNNNE-NN	R911384958	
								1	N	MS2N07-C1BRN-CMSH0-NNNNE-NN	R911384959	
								1	Y	MS2N07-C1BRN-CMSH1-NNNNE-NN	R911384960	
6 000	22.0	73.2	36.0	0.00210	0.000410	17.5	2.5	2	N	MS2N07-D0BRN-BMVH0-NNNNE-NN	R911384961	
								2	Y	MS2N07-D0BRN-BMVH2-NNNNE-NN	R911384962	
6 000	18.90	84.8	36.0	0.005290	0.000410	17.5	2.5	2	N	MS2N07-D1BNN-BMUH0-NNNNE-NN	R911384963	
								2	Y	MS2N07-D1BNN-BMUH2-NNNNE-NN	R911384964	
								1	N	MS2N07-D1BNN-CMSH0-NNNNE-NN	R911384965	
								1	Y	MS2N07-D1BNN-CMSH2-NNNNE-NN	R911384966	
6 000	29.2	109.5	36.0	0.00300	0.0000410	23.0	3.0	2	N	MS2N07-E0BQN-BMVH0-NNNNE-NN	R911384967	
								2	Y	MS2N07-E0BQN-BMVH2-NNNNE-NN	R911384968	
6 000	25.8	128.5	36.0	0.00752	0.0000410	23.0	3.0	2	N	MS2N07-E1BNN-BMVH0-NNNNE-NN	R911384969	
								2	Y	MS2N07-E1BNN-BMVH2-NNNNE-NN	R911384970	
6 000	30.2	70.5	53.0	0.00480	0.001470	23.5	5.0	2	N	MS2N10-C0BNN-BMVH0-NNNNE-NN	R911384875	
								2	Y	MS2N10-C0BNN-BMVH2-NNNNE-NN	R911384876	
6 000	51.0	142.0	53.0	0.00810	0.001470	34.0	5.0	2	N	MS2N10-D0BNN-BMVH0-NNNNE-NN	R911384877	
								2	Y	MS2N10-D0BNN-BMVH2-NNNNE-NN	R911384878	
6 000	67.7	214.0	90.0	0.01140	0.002700	45.0	7.0	2	N	MS2N10-E0BNA-BMAH0-NNNNE-NN	R911384881	
								2	Y	MS2N10-E0BNA-BMAH3-NNNNE-NN	R911384882	
								2	N	MS2N10-E0BNN-BMAH0-NNNNE-NN	R911384879	
								2	Y	MS2N10-E0BNN-BMAH3-NNNNE-NN	R911384880	

Motor attachment kits according to customer specification

The motor attachment for linear motion systems with Rexroth ball screw assembly consists of either an attachment kit with flange and coupling (MF) or a belt side drive (SD).

The available combinations are shown in the "Configuration and ordering" selection tables for each size. In addition to attachment kits for Rexroth motors, attachment kits for motors according to customer specification are also available. In order to determine the appropriate attachment kit, the connection geometry of the motor is crucial. Characteristics required to clearly determine motor geometry are shown below.

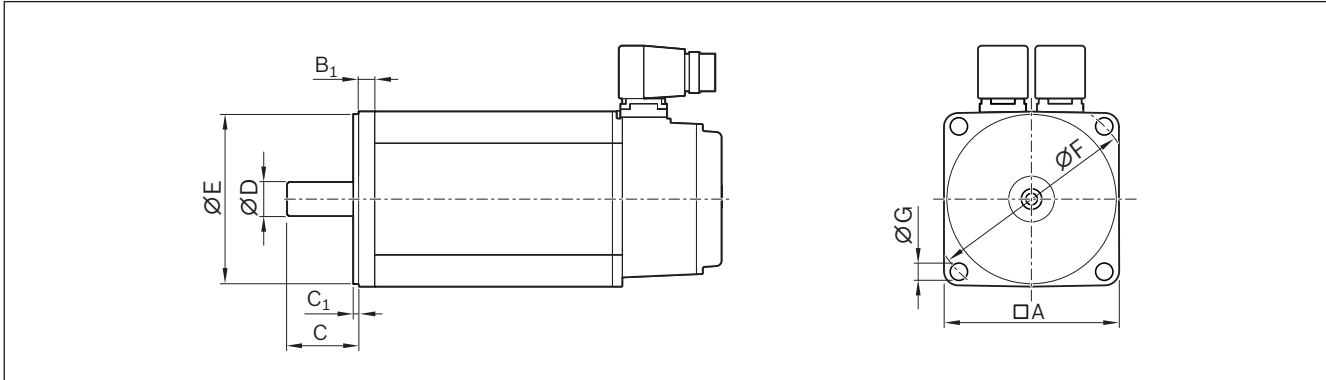

The dimensions queried result in a unique "motor geometry code":

	□□	-	□□	-	□□□	-	□□□	-	□□□	-	M	□□	-	□□□	-	□□□
ØD	=	Shaft diameter														
C	=	Shaft length														
ØE	=	Centering diameter														
C ₁	=	Centering depth														
ØF	=	Pitch diameter														
ØG	=	Drill hole for mounting screw (specify thread diameter)														
B ₁	=	Flange thickness														
A	=	Flange edge dimension														

Example illustration of servo motor IndraDyn S type MS2N04

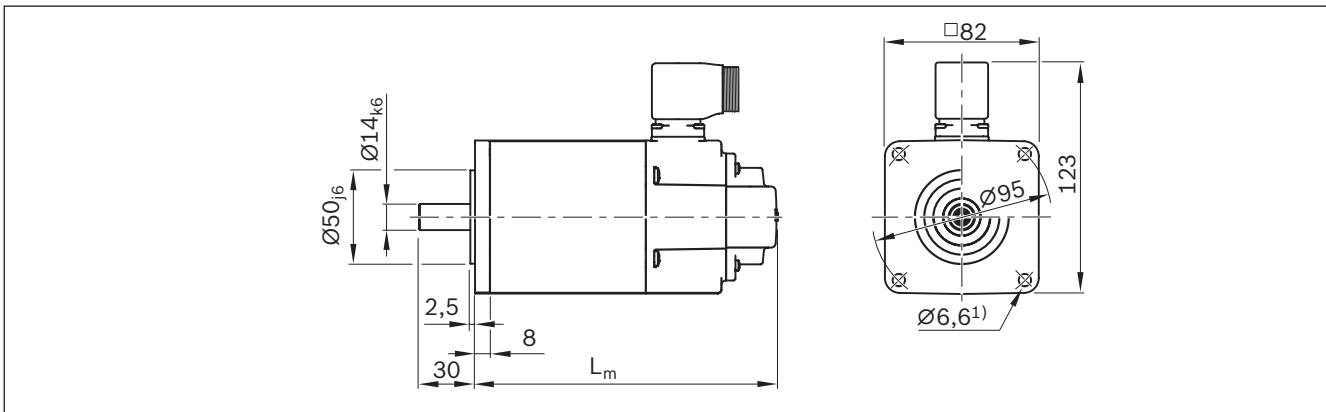

1 4 - 3 0 - 0 5 0 - 2 . 5 - 0 9 5 - M 0 6 - 0 0 8 - 0 8 2

¹⁾ The drill hole Ø 6.6 mm results in the type designation M06 for the geometry motor code (nominal thread diameter mounting screw M6).

Motor attachment kits for motors according to customer specification can be selected using the online configurator in the eShop. To do this, select the "mechanical interface" and "motor according to customer specification" option.

Size customer motor

Motor manufacturer

Motor type

Example

Size customer motor

Motor manufacturer

Motor type

Operating conditions and usage

Normal operating conditions

Ambient temperature with Bosch Rexroth servo motor	0 °C ... 40 °C, above 40 °C loss of performance
Ambient temperature Mechanical system (no dropping below dew point)	-10 °C ... 50 °C
Enclosure protection class	IP54, IP65 as an option
Duty cycle	100%
Normal stroke	The distance traveled per cycle is $\geq s_{min}$ (see diagram)

Stroke definition

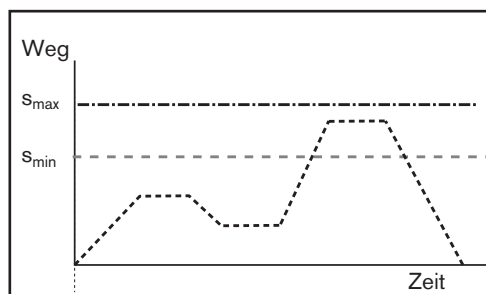

Normal stroke

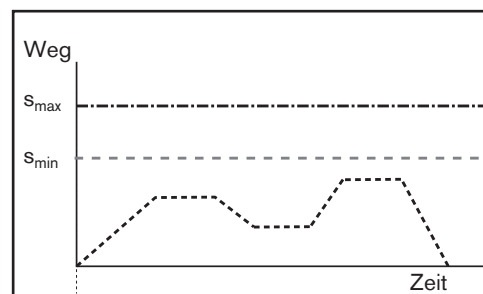

Short stroke

Short stroke: The distance traveled per cycle is $< s_{min}$ (see diagram).

Short stroke case 1:

Distance traveled in the cycle $< s_{min}$ and $> 2 \times$ screw lead:

- Perform the service life calculation with 69% of the dynamic load rating
- Halve the maintenance interval (see "Instructions EMC R320103102")

Short stroke case 2:

Distance traveled in the cycle $< s_{min}$ and $\leq 2 \times$ screw lead:

- Only permissible with regular lubricating strokes
- Perform the service life calculation with reduction to the dynamic load capacity
- Adapt maintenance interval

Contact Bosch Rexroth for further details.

Notes

For more information about intended use and safety, see "Safety instructions for linear motion systems R320103152".

For more information on assembly/start-up see "Instructions EMC R320103102".

PDF files of these documents can be found on the Internet at:
www.boschrexroth.com/mediadirectory

Parameterization (start-up)

The nameplate contains reference information on the production of the linear motion system as well as technical start-up parameters.

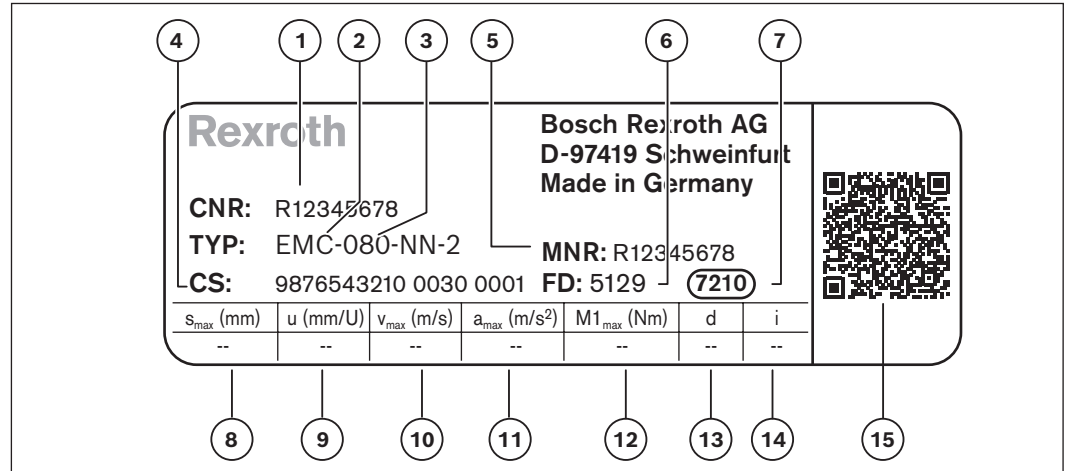

1	CNR	Customer's material number
2	TYP	Short product name
3	080	Size
4	CS	Customer information
5	MNR	Material number
6	FD	Date of manufacture
7	7210	Manufacturing location
8	s_{max}	Maximum travel range
9	u	Feed constant without motor attachment
10	v_{max}	Maximum travel speed
11	a_{max}	Maximum acceleration rate
12	$M1_{max}$	Maximum drive torque at motor journal
13	d	Direction of motor rotation to travel in positive (+) direction CW = clockwise CCW = counterclockwise
14	i	Gear ratio
15		QR-Code

Note

The values given describe the mechanical limit values of the axle.

Limit values for the included fastening elements and application-related installation cases are not taken into account here.

Lubrication and maintenance

Grease lubrication

The advantage of grease lubrication is that Rexroth ball screw assemblies can run for prolonged periods without needing relubrication.

All high-quality ball bearing lubricating greases can be used. Follow the lubricant manufacturer's instructions!

Greases in accordance with DIN 51825-K2K and, for higher loads, KP2K of grade NLGI 2 in accordance with DIN 51818 are recommended for the longest possible lubrication intervals. Tests have shown that grade NLGI 00 greases achieve only about 75% of the travel life of grade 2 at higher loads.

Lubrication position and notes on lubrication

Basic lubrication is applied in-factory before shipment. When selecting the LPG option (preserved version), initial lubrication by the customer is necessary prior to start-up.

The electromechanical cylinders are designed for grease lubrication using a manual grease gun with a lubricating pin, or for connecting to a central lubrication system (with liquid grease). Maintenance is limited to relubrication of the Rexroth ball screw assembly. In order to reach lubrication position L_{Lub} , move the piston rod to stroke position S_2 . For this purpose, move S_1 from the rear end position according to the table. For more information, see "Instructions EMC, R320103102".

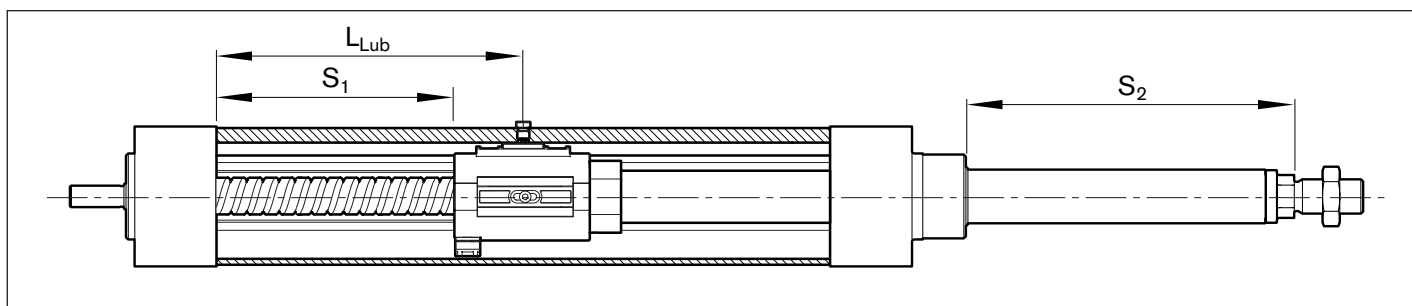

EMC	P ¹⁾ (mm)	L_{Lub} (mm)	S_1 (mm)	S_2 (mm)
32	5	$36.0 + s_{max}/2^2$	$21.5 + s_{max}/2^2$	$33.0 + s_{max}/2^2$
	10	$38.0 + s_{max}/2^2$	$18.5 + s_{max}/2^2$	$30.0 + s_{max}/2^2$
40	5	$35.5 + s_{max}/2^2$	$16.1 + s_{max}/2^2$	$28.1 + s_{max}/2^2$
	10	$40.0 + s_{max}/2^2$	$17.5 + s_{max}/2^2$	$29.5 + s_{max}/2^2$
	16	$48.0 + s_{max}/2^2$	$15.0 + s_{max}/2^2$	$27.0 + s_{max}/2^2$
50	5	$33.0 + s_{max}/2^2$	$10.0 + s_{max}/2^2$	$24.0 + s_{max}/2^2$
	10	$42.5 + s_{max}/2^2$	$10.0 + s_{max}/2^2$	$24.0 + s_{max}/2^2$
	20	$52.0 + s_{max}/2^2$	$10.0 + s_{max}/2^2$	$24.0 + s_{max}/2^2$
63	5	$35.0 + s_{max}/2^2$	$10.0 + s_{max}/2^2$	$24.0 + s_{max}/2^2$
	10	$44.5 + s_{max}/2^2$	$10.0 + s_{max}/2^2$	$24.0 + s_{max}/2^2$
	25	$60.5 + s_{max}/2^2$	$10.0 + s_{max}/2^2$	$24.0 + s_{max}/2^2$
80	5	$37.0 + s_{max}/2^2$	$10.0 + s_{max}/2^2$	$26.0 + s_{max}/2^2$
	10	$49.0 + s_{max}/2^2$	$7.5 + s_{max}/2^2$	$24.5 + s_{max}/2^2$
	20	$53.0 + s_{max}/2^2$	$7.5 + s_{max}/2^2$	$24.5 + s_{max}/2^2$
	32	$70.5 + s_{max}/2^2$	$7.5 + s_{max}/2^2$	$24.5 + s_{max}/2^2$
100	5	$36.0 + s_{max}/2^2$	$7.9 + s_{max}/2^2$	$23.9 + s_{max}/2^2$
	10	$43.0 + s_{max}/2^2$	$10.5 + s_{max}/2^2$	$27.5 + s_{max}/2^2$
	20	$52.0 + s_{max}/2^2$	$4.5 + s_{max}/2^2$	$21.5 + s_{max}/2^2$
	40	$79.5 + s_{max}/2^2$	$4.5 + s_{max}/2^2$	$21.5 + s_{max}/2^2$
100XC	10	$66.5 + s_{max}/2^2$	$15.3 + s_{max}/2^2$	$43.4 + s_{max}/2^2$
	20	$77.5 + s_{max}/2^2$	$18.4 + s_{max}/2^2$	$46.5 + s_{max}/2^2$

¹⁾ BASA lead

²⁾ s_{max} : maximum travel range of the EMC (see name plate)

Recommended lubricants**Note**

Do not use lubricants with solid particles (e.g. graphite or MoS₂ additives).

For central lubrication systems we recommend using Dynalub 520.

Grease	
Consistency class NLGI 2 per DIN 51818	Consistency class NLGI 00 per DIN 51818
<ul style="list-style-type: none"> - Dynalub 510 (Bosch Rexroth) Cartridge (400 g) R341603700 Bucket (5 kg) R341603500 - Berulub FG H2 SL (Bechem) NSF-H1 grease Cartridge (400 g) R341604600 	<ul style="list-style-type: none"> - Dynalub 520 (Bosch Rexroth) Cartridge (400 g) R341604300 Bucket (5 kg) R341604200
Can also be used	Can also be used
<ul style="list-style-type: none"> Elkalub GLS 135 / N2 (Chemie-Technik) Tribol GR 100-2 PD (Castrol) 	<ul style="list-style-type: none"> Elkalub GLS 135 / N00 (Chemie-Technik) Tribol GR 100-00 PD (Castrol)

Initial lubrication with NSF-H1 lubricant:

Ball screw assembly and other components are pre-lubricated with NSF-H1 lubricant.

Even when using an H1 lubricant, the EMC is only conditionally suitable for use in the foodstuff industry.

H1 lubricants or separating agents (anti-corrosion agents) only have H1 approval if they are available with grade purity in an unmixed state. A blend of two H1 approval lubricants or separating agents does not have H1 approval. Owing to the preservation used for the ball screw assembly, the H1 lubricant in the EMC does not have grade purity.

Information on the materials used is available upon request.

In case of any doubt, please consult Bosch Rexroth.

Connection for central lubrication system

For additional information, please refer to chapter "Attachments and accessories".



Documentation

Standard report Option 01

The standard report serves to confirm that the checks listed in the report have been carried out and that the measured values lie within the permissible tolerances.

Checks listed in the standard report:

- Functional checks of mechanical components
- Functional checks of electrical components
- Design as per order confirmation

Measurement of frictional torque of complete system Option 02

All items as per the standard report.

The friction torque M is measured over the entire travel range.

Example diagram

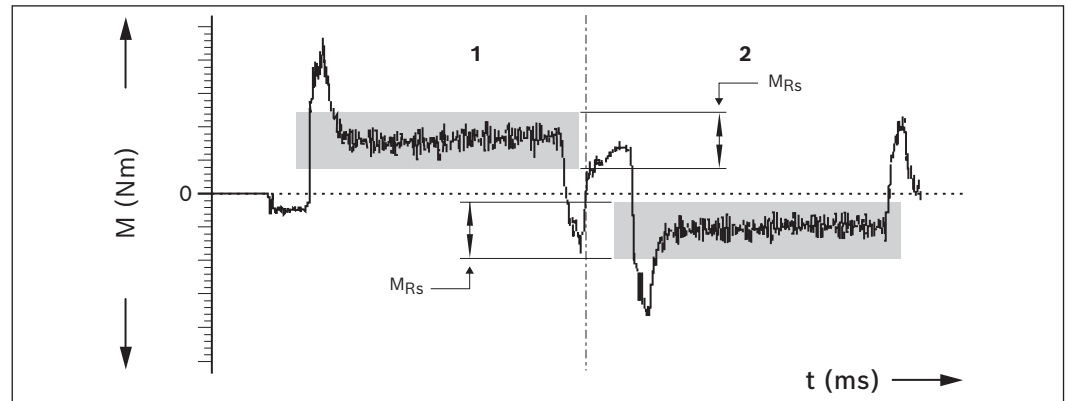

- 1 Advance
2 Return

M_{Rs} = Friction torque (N)
 t = Travel time (ms)

Lead deviation of screw drive Option 03

All items as per the standard report.

In addition to the graphical illustration (see figure), a measurement report is included in tabular form.

Example diagram

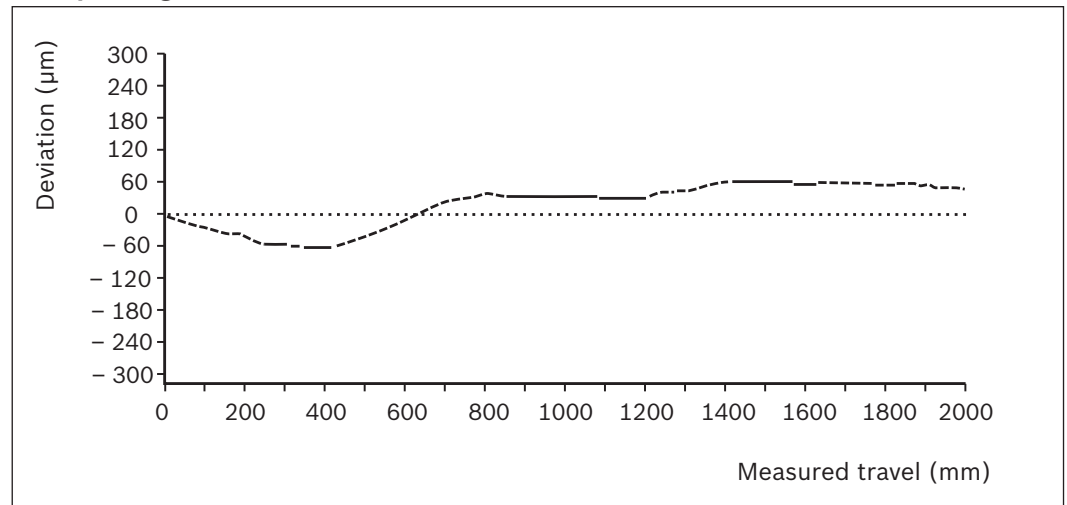

Abbreviations

Abbreviation/ index	Name	Unit
a	Acceleration	(m/s ²)
a_{max}	Maximum acceleration rate	(m/s ²)
BASA	Ball screw assembly	(–)
C	Dynamic load capacity, guideway	(N)
d₀	Nominal diameter of ball screw assembly	(mm)
F₁, F₂, ... F_n	Axial load during phases 1 ... n	(N)
F_m	Equivalent dynamic axial load	(N)
i	Gear ratio	(–)
J_{br}	Mass moment of inertia of the motor brake	(kgm ²)
J_{ex}	Mass moment of inertia of the mechanical system	(kgm ²)
J_{ge}	Mass moment of inertia of the gear at motor journal	(kgm ²)
J_m	Mass moment of inertia of motor	(kgm ²)
J_s	Mass moment of inertia	(kgm ²)
J_t	Translative mass moment of inertia of external load based on the linear motion system screw journal	(kgm ²)
k_{g fix}	Constant for fixed portion of mass	(kg)
k_{g var}	Constant for variable-length portion of mass	(kg/mm)
k_{J fix}	Constant for fixed portion of mass moment of inertia	(kgmm ²)
k_{J m}	Constant for mass-specific portion of mass moment of inertia	(mm ²)
k_{J var}	Constant for variable-length portion of mass moment of inertia	(kgmm)
L	Nominal service life – in revolutions – in meters	(min ⁻¹) (m)
L_{ad}	Additional length	(mm)
L_h	Nominal service life	(h)
L_m	Length of the motor	(mm)
m_{br}	Mass of the brake	(kg)
m_{ex}	Moved external load	(kg)
m_{fc}	Mass of flange and coupling	(kg)
m_m	Mass of the motor	(kg)
m_s	Mass of the linear system (without attachments)	(kg)
m_{sd}	Mass of the timing belt side drive	(kg)
M₀	Continuous motor torque	(Nm)
M_m	Equivalent dynamic torque	(Nm)
M_{max}	Max. possible motor torque	(Nm)
M_{mech}	Maximum permissible drive torque for mechanical system	(Nm)
M_p	Maximum permissible drive torque (at drive journal)	(Nm)
M_R	Frictional torque at motor journal	(Nm)
M_{Rs}	Friction torque of system	(Nm)

Abbreviation/ index	Name	Unit
M_{stat}	Static load moment	(Nm)
n₁, n₂, ... n_n	Rotary speed in acceleration and braking phases	(min ⁻¹)
n_{mech}	Maximum permissible rotary speed for mechanical system	(min ⁻¹)
n_{max}	Max. motor speed	(min ⁻¹)
n_p	Maximum permissible rotary speed	(min ⁻¹)
P	Screw lead	(mm)
s_e	Excess travel (excess travel s _e should be greater than braking distance. The acceleration travel can be used as a guideline value for braking distance.)	(mm)
s_{eff}	Effective stroke	(mm)
s_{min}	Min. travel range	(mm)
s_{max}	Maximum travel	(mm)
t₁, t₂, ... t_n	Time for phase 1 ... n	(s)
u	Feed constant	(mm/U)
v₁, v₂, ... v_n	Speed in phase 1 ... n	(m/s)
v_{max}	Maximum permissible speed	(m/s)
v_{mech}	Maximum permissible speed of mechanical system	(m/s)
v_m	Average linear speed	(m/s)
V	Ratio of mass moments of inertia of drive chain and motor	(–)
π	Pi	(–)

Ordering example

EMC 32 - EMC 50		Size short product name	Max. travel range mm	Housing	Drive	Lubrication ¹⁾	Switch ⁴⁾	Version	Motor attachment	Motor	Documentation							
				Standard PFS enclosure protection class PFS enclosure protection class + IR	BASA d ₀ x P (mm)	LSS LCF LPG LHG LFL ²⁾	Sensor profile without switch and sensor profile Switches 1, 2, 3, 4		Gear ratio Attachment kit ³⁾	Motor code ³⁾ Cables Brake 1 cable Brake Motor connector position	Standard report Measurement reports							
EMC-032-NN-2	01	02	03	12 x 5	01		PNP NC contact 120	OF01 without motor attachment			000							
				12 x 10	02	RV01 with flange		i = 1										
						RV02 with belt side drive												
	16 x 5	01	03	01	02	03	04	05	00	80		NPN NC contact 121	OF01 without motor attachment			090		
													16 x 10	02	MF01 with flange		i = 1	
															RV01 with belt side drive			
16 x 16	03	01	02	03	04	05	00	80	NPN NO contact 122	OF01 without motor attachment			180					
										20 x 5	01	MF01 with flange		i = 1.5				
												RV01 with belt side drive						
EMC-050-NN-2	01	02	04	20 x 5	01		NPN NO contact 123	OF01 without motor attachment			270							
				20 x 10	02	RV01 with flange		i = 1										
						RV02 with belt side drive												
			20 x 20	04														

Flange (F)	Motor connector position	0°	90°	180°	270°
MF01		000	090	180	270

★ standard delivery

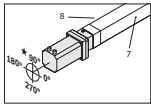

Example: Flange MF01 Motor connector position 90°

RV01	RV02	RV03
0°	90°	180°
180°	270°	0°

Example: Belt side drive RV02 Motor connector position 90°

RV01	RV02	RV03
0°	90°	180°
180°	270°	0°

Explanation of the order parameters and ordering example
★ Chapter "Ordering example".

★ standard delivery

Befestigungselement		Ausführung				Ausführung			
		1	2	3	4	5	6		
ohne Flansch OF01		00 ohne	00 ohne	00 ohne	00 ohne	00 ohne	00 ohne		
mit Flansch und Kupplung MF01		01	01	01 ¹⁾		01 ²⁾			
mit Riemenvorlege RV01 bis RV03		02	02	03 ¹⁾		03 ¹⁾			
		Gabelbefestigung mit Kraftmessbolzen	Edelstahl	04		05 ¹⁾	EMC-32 - EMC-50		
				06		06	EMC-63 - EMC-100XC		
				EMC-32 - EMC-50		07	EMC-32 - EMC-50		
				EMC-63 - EMC-100XC		08	EMC-32 - EMC-50		
				EMC-63 - EMC-100XC		09	EMC-63 - EMC-100XC		
				Edelstahl		10	Gabelbefestigung mit Kraftmessbolzen		

¹⁾ Nur vertikal zulässig
²⁾ Befestigungselemente bei Ausführung mit Flansch und Kupplung bereits abgebaut

Hinweis: Befestigungselemente liegen bei

Electromechanical cylinder EMC-040-NN-2

Ordering data	Option	Explanation	
Short product name	EMC-040-NN-2		
Max. travel range	580	580 mm	
Housing	01	Standard	
Drive	02	Rexroth ball screw assembly 16 x 10	
Lubrication	02	LCF	
Sensor profile	80	With sensor profile	
Switch 1	122	PNP NO contact	
Version	MF01	With flange	
Motor attachment	06	Attachment kit (flange and coupling) for MS2N03	
Motor	203	MS2N03, without brake, 1 cable	
Documentation	01	Standard	
Fastening elements	Group 1	00	None
	Group 2	01	Female spherical rod end bearing
	Group 3	06	Foot mounting
	Group 4	00	None
	Group 5	05	Foot mounting
	Group 6	00	None

Inquiry or ordering

Bosch Rexroth AG
 97419 Schweinfurt
 Germany

**You can find
 local contact
 person at:**

www.boschrexroth.com/adressen

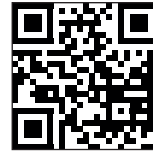

To be completed by customer	Option
Inquiry	
Order	

Ordering data	Option																		
Short product name	E	M	C	-					-			-	2						
Max. travel range (mm) =																			
Housing =																			
Drive =																			
Lubrication =																			
Sensor profile =																			
Switch 1 =																			
Switch 2 =																			
Switch 3 =																			
Switch 4 =																			
Version =																			
Motor attachment =					∅D	-	C	-	∅E	-	C ₁	-	∅F	-	∅G	-	B ₁	-	A
Motor geometry code =														M					
Motor =																			
Documentation =																			
Fastening elements =																			Group 1
																			Group 2
																			Group 3
																			Group 4
																			Group 5
																			Group 6

Order quantity	Quantity
one-off	
monthly	
annually	
per order	
comments	

From	
Company	
Address	
Name	
Department	
Fax	
Email	

Further information

Here you will find extensive information on products, eShop, safety engineering, as well as training and services offered.

[EMC product information](#)

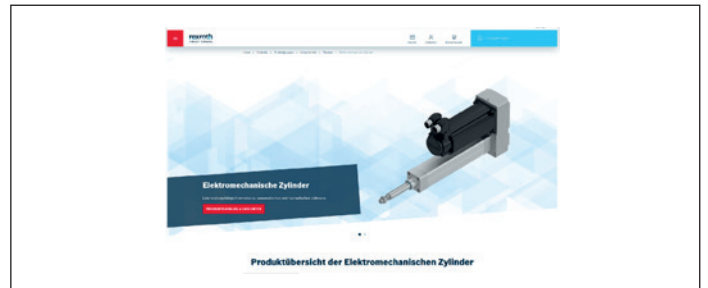

[Configurators and tools](#)



[Homepage Bosch Rexroth](#)

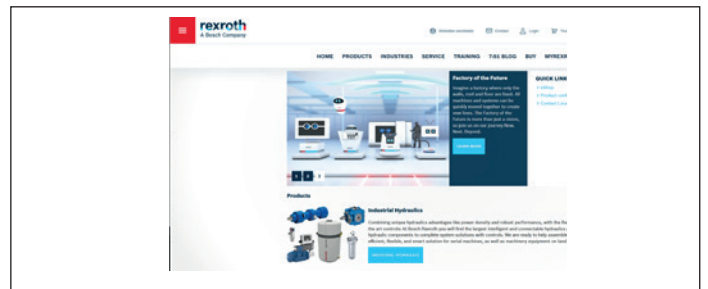

[eShop](#)



[GoTo Europe:](#)

- GoTo Europe Focused Delivery Program**
 Going to your product in only three steps:
1. Select the product
 2. View the product data
 3. Order the product

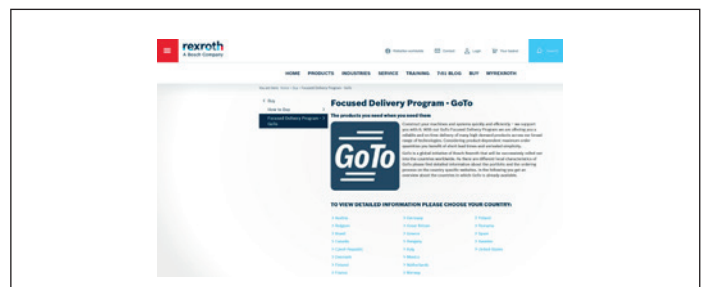

Bosch Rexroth AG

Ernst-Sachs-Straße 100
97424 Schweinfurt, Germany
Tel. +49 9721 937-0
Fax +49 9721 937-275
www.boschrexroth.com

Find your local contact person here:

www.boschrexroth.com/contact

