

# Compact modules CKK/CKR

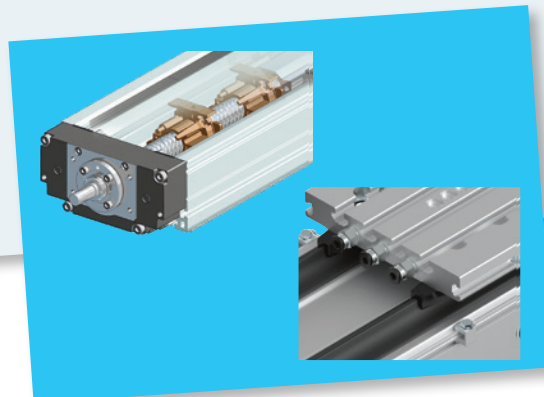
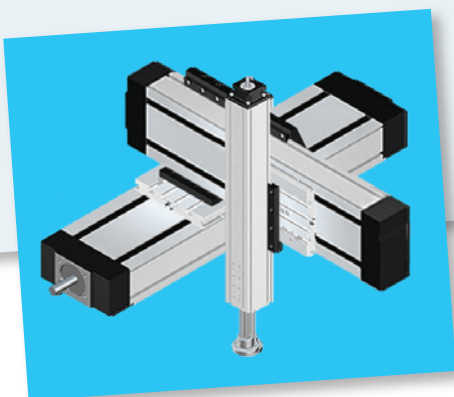
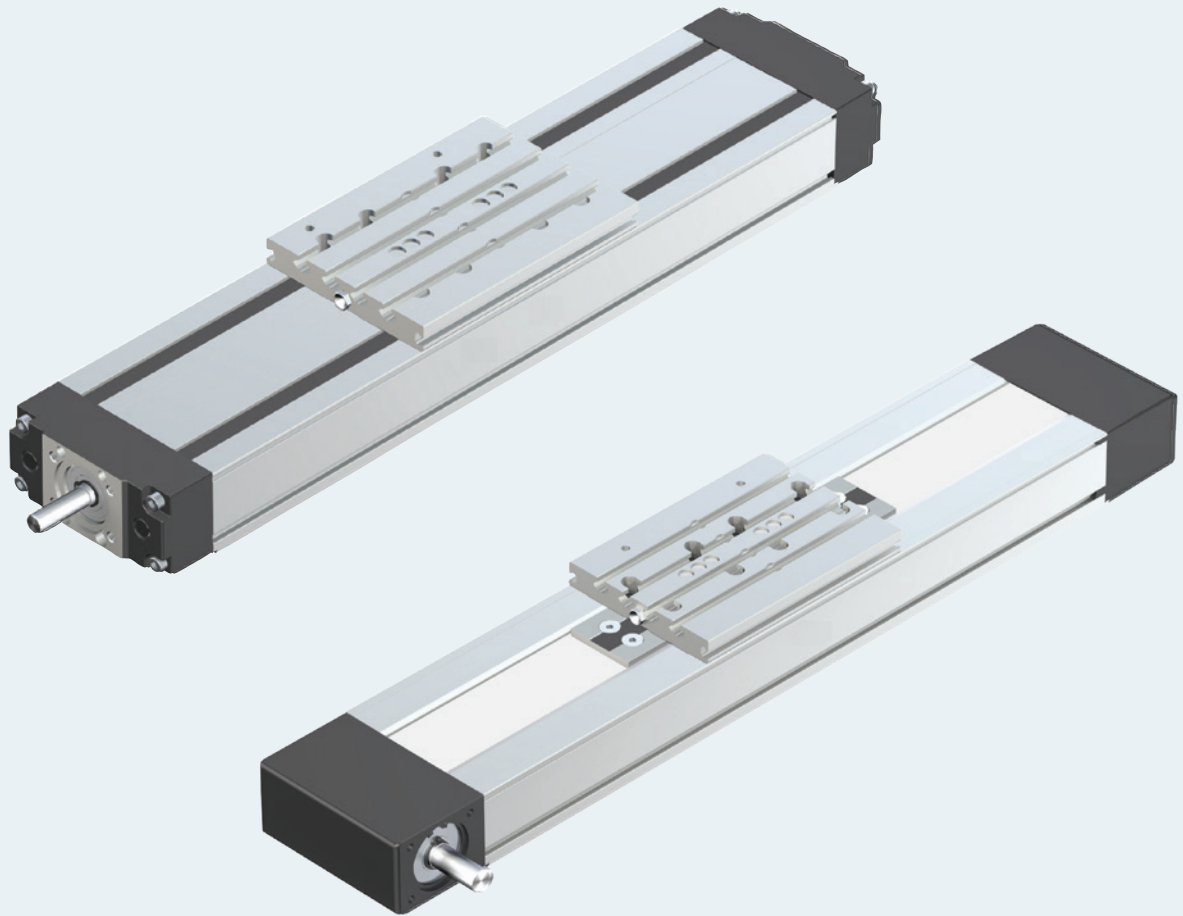

**Identification system for short product names**

Compact modules are identified by the type designation and size.

<b>Example</b>		<b>C</b>	<b>K</b>	<b>K</b>	<b>- 110 -</b>	<b>NN</b>	<b>- 1</b>
<b>System</b>	= Compact module ( <b>C</b> )						
<b>Guideway</b>	= Ball rail system ( <b>K</b> )						
<b>Drive</b>	= Ball screw assembly ( <b>K</b> ) Toothed belt drive ( <b>R</b> )						
<b>Size</b>	= 070 / 090 / <b>110</b> / 145 / 200						
<b>Version</b>	= Standard version ( <b>N</b> )						
<b>Generation</b>	= Product generation <b>1</b>						

**Changes/additions at a glance**

- ▶ MS2N motors revised: chapter "Configuration and ordering" and chapter "Motors"
- ▶ "Automation package" amended: in the product description, in the option tables, for accessories

# Contents

<b>Contents</b>	<b>3</b>		
<b>Product description</b>	<b>4</b>		
Axis / drive / software	<b>6</b>		
<b>Lubrication versions</b>	<b>8</b>		
<b>Form of delivery</b>	<b>10</b>		
<b>Overview of types with load capacities</b>	<b>12</b>		
<b>Compact modules with ball screw assembly (CKK)</b>	<b>14</b>		
<b>Product overview</b>	<b>14</b>		
<b>Structural design</b>	<b>18</b>		
<b>Technical data</b>	<b>20</b>		
General technical data	20		
Drive data	22		
<b>Technical data for CKK-200 with screw support</b>	<b>24</b>		
General technical data	24		
Drive data	26		
<b>Technical data</b>	<b>28</b>		
<b>Diagrams</b>	<b>30</b>		
Permissible drive torque	30		
Permissible speed	32		
<b>Configuration, order</b>	<b>34</b>		
CKK-070	34		
CKK-090	36		
CKK-110	38		
CKK-145	40		
CKK-200	42		
<b>Dimension drawings</b>	<b>44</b>		
Frame	44		
Carriages	48		
Motor attachment	50		
<b>Compact modules with toothed belt drive (CKR)</b>	<b>52</b>		
<b>Product overview</b>	<b>52</b>		
<b>Structural design</b>	<b>53</b>		
<b>Technical data</b>	<b>54</b>		
General technical data	54		
Drive data	54		
Gear data	56		
<b>Configuration, order</b>	<b>58</b>		
CKR-070	58		
CKR-090	60		
CKR-110	62		
CKR-145	64		
CKR-200	66		
<b>Dimension drawings</b>	<b>68</b>		
Frame	68		
Carriages	72		
		Motor attachment	74
		Adapter flange	75
		<b>Attachments and accessories</b>	<b>76</b>
		<b>Mounting/mounting accessories</b>	<b>76</b>
		<b>Connection plates</b>	<b>80</b>
		<b>Cover</b>	<b>85</b>
		<b>Connecting shafts</b>	<b>86</b>
		<b>Nozzle pipe</b>	<b>89</b>
		<b>Frequency meter</b>	<b>89</b>
		<b>Motors</b>	<b>90</b>
		Motor attachment kits according to customer specification	90
		IndraDyn S - Servo motors MSM	92
		IndraDyn S - Servo motors MS2N	94
		<b>Automation package</b>	<b>96</b>
		Motor/controller combinations	97
		Motor/controller/cable combinations	100
		<b>Type designation</b>	<b>104</b>
		<b>Switching system</b>	<b>108</b>
		Overview of attachment variants	108
		Sensors	112
		Switches	120
		Extensions	124
		Connectors	126
		Adapters	127
		Distributors	128
		Combination examples	132
		Socket and connector	134
		<b>Service and information</b>	<b>136</b>
		<b>Operating conditions</b>	<b>136</b>
		<b>Lubrication</b>	<b>137</b>
		<b>Overview of lubrication versions</b>	<b>137</b>
		Lubricants	138
		<b>Parameterization (commissioning)</b>	<b>140</b>
		<b>Documentation</b>	<b>141</b>
		<b>Project planning/calculation</b>	<b>142</b>
		<b>Calculation principles</b>	<b>142</b>
		<b>Drive sizing</b>	<b>146</b>
		<b>Calculation examples</b>	<b>152</b>
		<b>Abbreviations</b>	<b>160</b>
		<b>Ordering example CKK</b>	<b>162</b>
		<b>Inquiry/order form for CKK</b>	<b>163</b>
		<b>Ordering example CKR</b>	<b>164</b>
		<b>Inquiry/order form for CKR</b>	<b>165</b>
		<b>Further information</b>	<b>166</b>

## Product description

### Characteristic features

- ▶ Five fine-tuned sizes based on a compact precision aluminum profile with two integrated preloaded ball rail systems
- ▶ Identical external dimensions between compact module types CKK and CKR.
- ▶ Four different lube versions (see the following pages and the chapter "Lubrication")
- ▶ Ready-to-install compact modules in any length up to  $L_{max}$
- ▶ Aluminum carriages available in different versions depending on load

### Further highlights

- ▶ Flexible thanks to options
- ▶ Ready-to-install with various attachment parts
- ▶ Centering holes for simple combination with other linear motion systems and connection elements
- ▶ Economical maintenance thanks to one-point lubrication feature (grease lubrication) from both sides or via the carriage or via a connection plate

**Compact modules CKK**

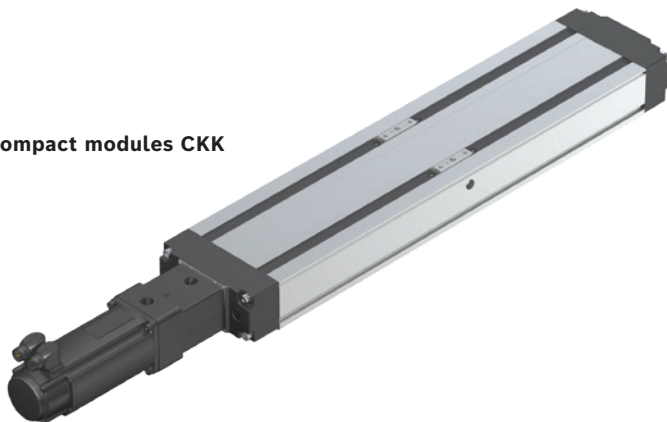

**Compact modules CKR**

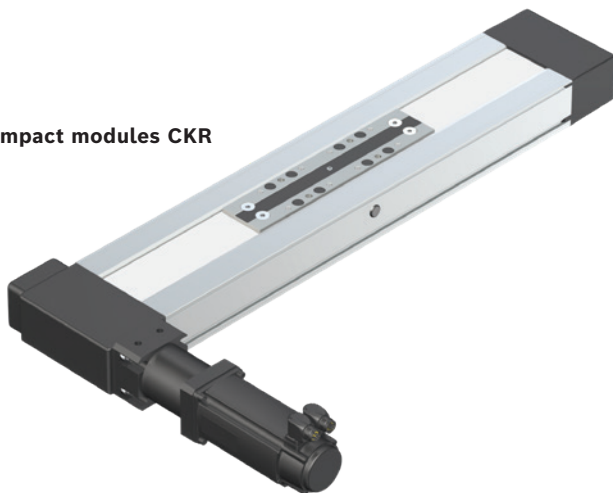

Compact modules are available as complete solutions with motor, controller, and control system. For more information, see the "Axis / drive / software" chapter.

**Compact modules CKK****with ball rail system and ball screw assembly**

- ▶ Drive via precision ball screw assembly
- ▶ Screw support for the realization of high speeds on long assembly lengths for CKK-200
- ▶ Protection of installation elements through a cover plate and two cover strips; Optionally increased protection thanks to "Resist" cover
- ▶ Repeatability of up to  $\pm 0.005$  mm

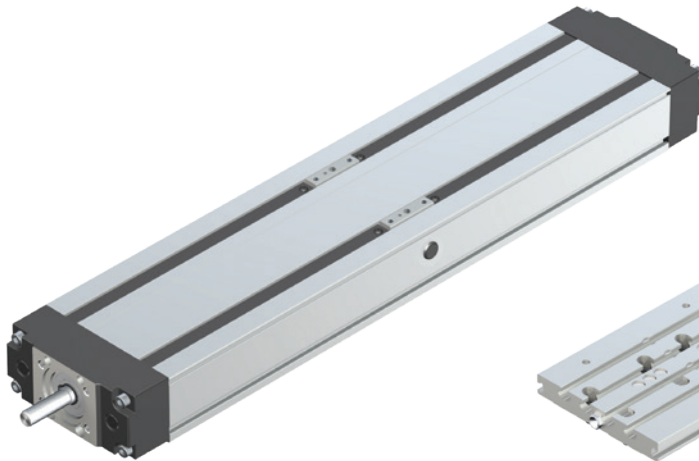
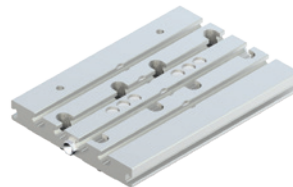
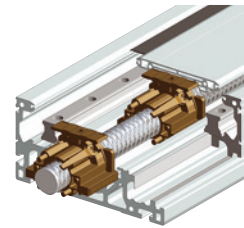
**"Resist" cover****Connection plates****Screw support SPU  
for CKK-200****Compact modules CKR****with ball rail system and toothed belt drive**

- ▶ Realization of greater lengths of up to 10,000 mm
- ▶ Preloaded toothed belt
- ▶ Intelligent toothed belt guide protects inner components
- ▶ Repeatability of up to  $\pm 0.05$  mm

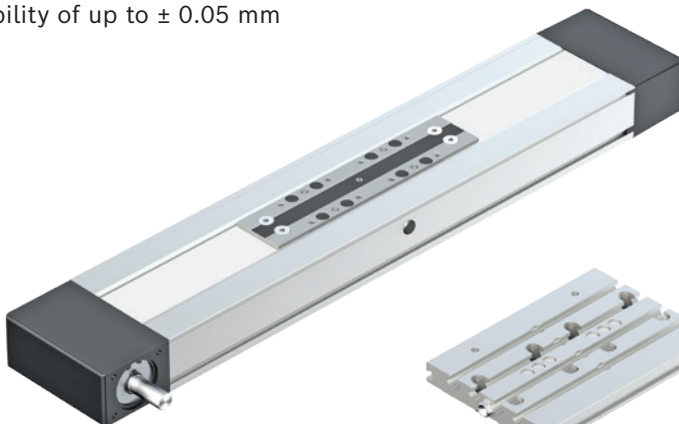
**Connection plates**

Axis / drive / software

**SIMPLY SAVE TIME AND MONEY:  
EVERYTHING FROM A SINGLE SOURCE.  
WITH A SINGLE MATERIAL NUMBER.**

So that you can realize fully automated movements with single axes faster, all components are now available in one package.

With just a few clicks, you can design and configure motor, drive controller, mains filter and cable online, and optionally also the software.

Ordered with just one material number, your solution will be available to you in now time – and immediately ready for operation thanks to the axis parameters stored in the motor. If necessary, the proven Rexroth service is always available to assist you.

Really everything from a single source.  
Can it be easier?



# Faster automation:

# single axis + drive + software in one package.



### 3 ORDERING OPTIONS, ALL FREEDOMS:

1. **Single axis**
2. **Single axis + drive**  
(incl. mains filter/cable)
3. **Single axis + drive + software**  
(incl. mains filter/cable) as plug & play complete solution

► For further information see chapter "Configuration and ordering" and chapter "Automation package".

## Lubrication versions

Two drive versions:

- ▶ Compact modules CKK with ball rail system and ball screw assembly
- ▶ Compact modules CKR with ball rail system and toothed belt drive

Four different lube versions

- ▶ Standard lubrication (LSS)
- ▶ Preserved (LPG)
- ▶ Carriage with connection plate prepared for connection to central lubrication systems for liquid grease (LCF)
- ▶ Carriage with connection plate prepared for connection to central lubrication systems for oil (LCO)

Versions for oil and liquid grease lubrication prepared for connection to central lubrication systems

- ▶ High operational reliability through automated relubrication
- ▶ Need-based maintenance reduces consumption of lubricant, while ensuring high availability
- ▶ More degrees of freedom as lubrication is not dependent on position and installation location
- ▶ Low-cost unmanned maintenance

### **Notes:**

#### **LSS:**

- ▶ Initial lubrication by Bosch Rexroth
- ▶ Relubrication using manual grease gun

#### **LPG:**

- ▶ Ball rail system and ball screw assembly only with corrosion prevention
- ▶ Relubrication using manual grease gun
- ▶ Basic lubrication required

#### **LCF:**

- ▶ Prepared for connection to central lubrication systems for liquid grease (grade NLGI 00 in accordance with DIN 51818)
- ▶ Lubrication with liquid grease only via single-line piston distributor system
- ▶ Basic lubrication required

#### **LCO:**

- ▶ Prepared for connection to central lubrication systems for oil
- ▶ Oil lubrication only via single-line piston distributor system
- ▶ Runner block and ball screw assembly nut with integrated non-return valves
- ▶ Basic lubrication required



**Compact modules CKK**  
**Lubrication version LSS, LPG**

- ▶ Grease lubrication with manual grease gun via frame, carriage or via connection plate

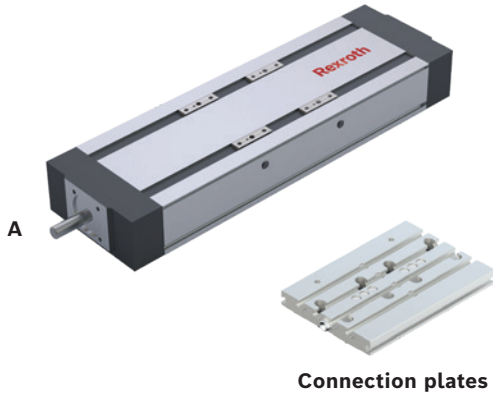

**Connection plates**

**Compact modules CKR**  
**Lubrication version LSS, LPG**

- ▶ Grease lubrication with manual grease gun via frame, carriage or via connection plate

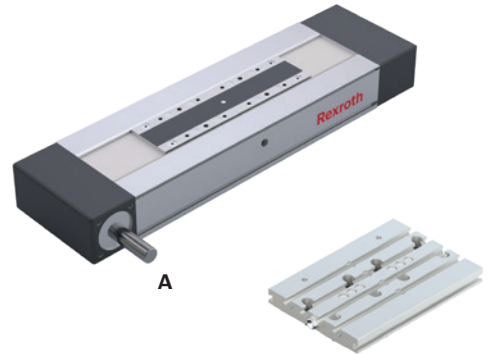

**Connection plates**

**Lubrication version LCF, LCO**

- ▶ 3 lube fittings
- ▶ Prepared for connection to central lubrication systems

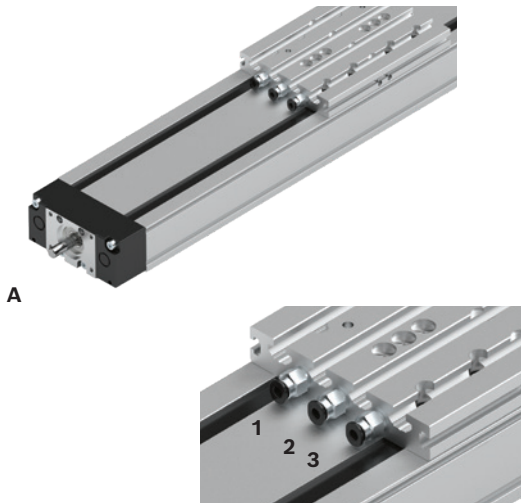

- A** Drive side
- 1** Lube connection, runner block left
- 2** Lube connection, runner block right
- 3** Lube connection, ball screw assembly

**Lubrication version LCF, LCO**

- ▶ 2 lube fittings
- ▶ Prepared for connection to central lubrication systems

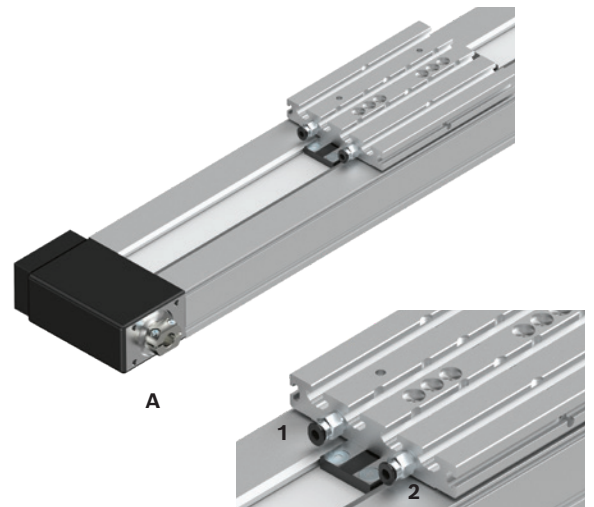

- A** Drive side
- 1** Lube connection, runner block left
- 2** Lube connection, runner block right

## Form of delivery

Compact modules with ball rail system and ball screw or toothed belt drive are delivered completely assembled.

### **Motor attachment**

If a combination of motor and motor attachment has been selected, then the components are attached as shown in the figure, which also shows the location of the motor connector.

When ordering motor attachments without motor, not all parts can be mounted.

Final assembly must then be carried out by the customer.

All necessary instructions and parameters for professional assembly are included.

### **Available options**

Cable duct, mounting duct, switch, switching cam and socket with connector are included as loose parts.

### **Lubrication**

Compact modules are delivered with initial greasing, depending on the lubricant used.

For more information on lubricants, see Chapter "Lubrication".

Documentation

Each compact module is supplied with the accompanying documentation.

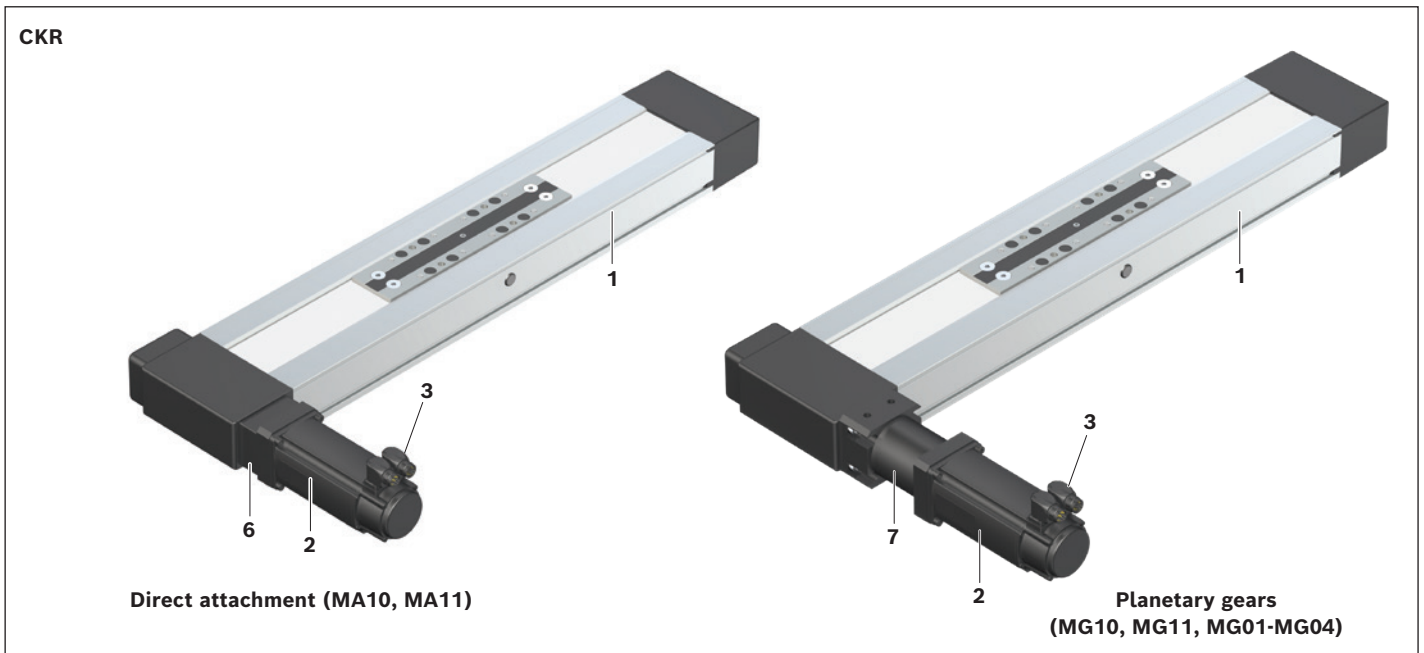
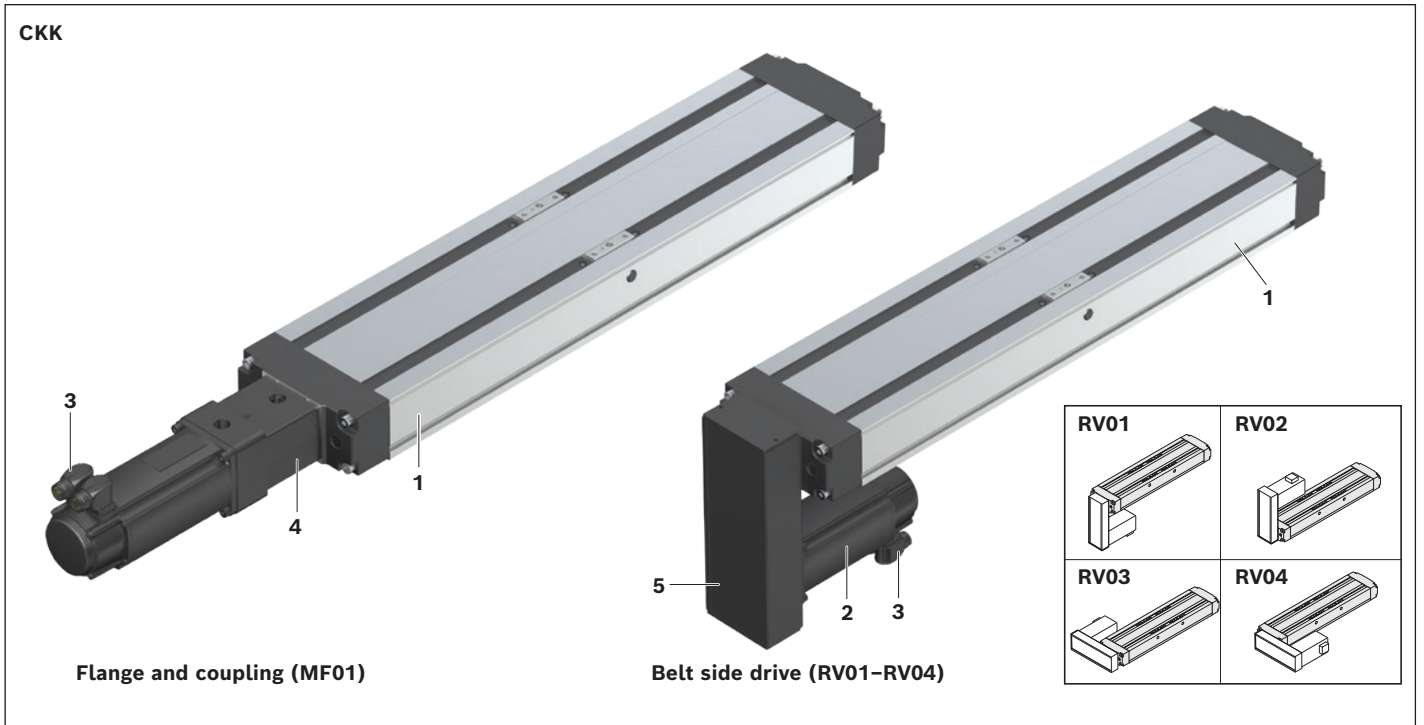

All CKK and CKR versions that have been configured with "Carriage with connection plate" are supplied without the lube ports in the frame. All configured compact modules with carriages without connection plate are still supplied with lube ports in the frame.

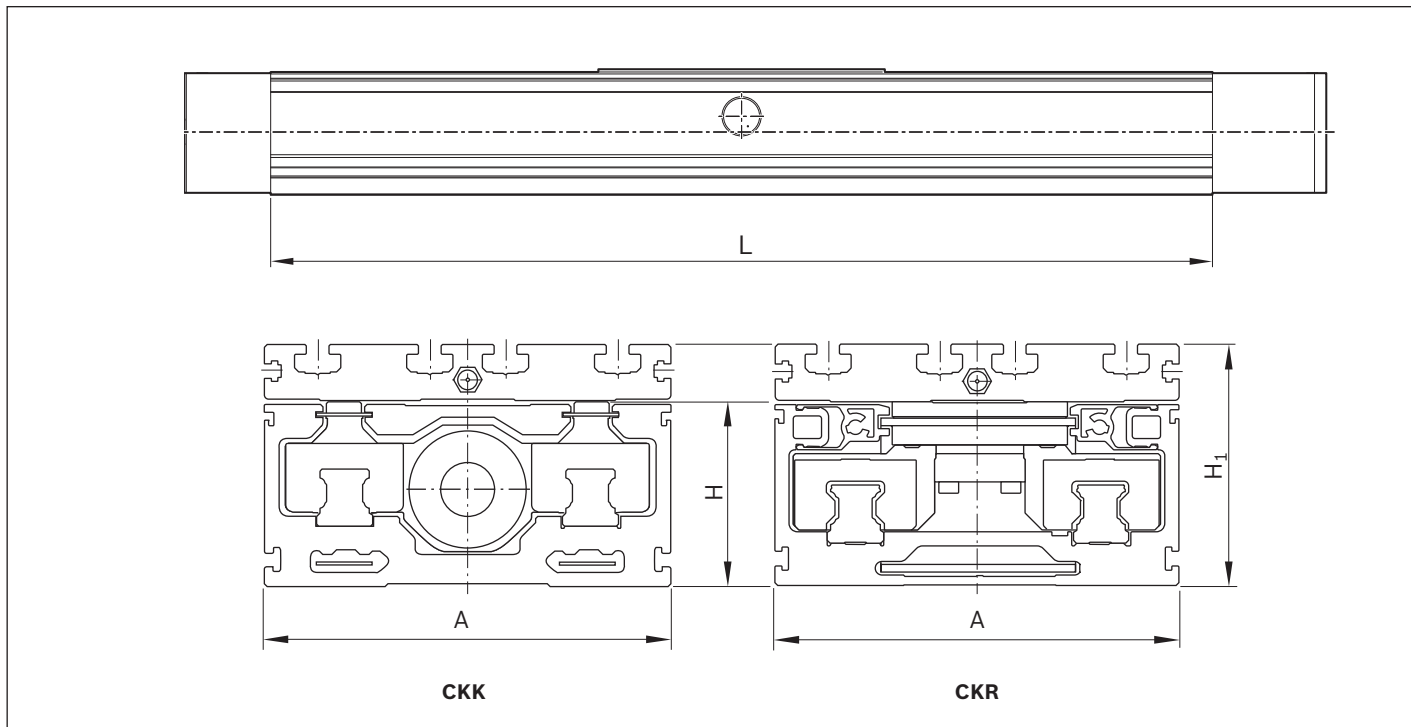

- 1 Linear motion system
- 2 Motor
- 3 Motor connector
- 4 Flange and coupling
- 5 Belt side drive
- 6 Direct attachment (flange)
- 7 Gearing

## Overview of types with load capacities

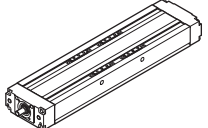
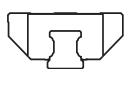

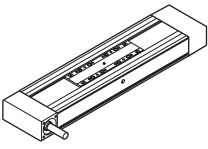
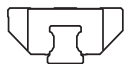
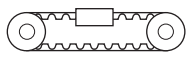
Compact modules	Type	Guideway	Drive
	CKK	 Ball rail system	 Ball screw assembly
	CKR	 Ball rail system	 Toothed belt drive

**Note on dynamic load capacities and moments**

Determination of the dynamic load capacities and moments is based on a total travel of 100,000 m. Often only 50,000 m of total travel are actually stipulated. For comparison: Multiply values C,  $M_t$  and  $M_L$  by a factor of 1.26.

Size	070			090			110			145			200		
Dimensions (mm)	A	H	H <sub>1</sub>	A	H	H <sub>1</sub>	A	H	H <sub>1</sub>	A	H	H <sub>1</sub>	A	H	H <sub>1</sub>
		70	32	44.5	90	40	56	110	50	66	145	65	85	200	100
L <sub>max</sub> (mm)	650			750			1,500			1,800			2,200 <sup>1)</sup>		
Dynamic load capacity C <sub>gw</sub> <sup>2)</sup> (N)	3,830			7,505			32,035			76,025			121,185		
L <sub>max</sub> (mm)	1,500			5,500			5,500			5,500			10,000		
Dynamic load capacity C <sub>gw</sub> <sup>2)</sup> (N)	3,830			7,505			32,035			76,025			121,185		

<sup>1)</sup> Up to 5,500 mm are possible with screw support (SPU).  
<sup>2)</sup> The maximum permitted dynamic values are specified here. They vary depending on the carriage length.

# Compact modules with ball screw assembly (CKK)

## Product overview

### Features

- ▶ Five fine-tuned sizes based on a compact precision aluminum profile with two integrated preloaded ball rail systems
- ▶ Four different lube versions
- ▶ Ready-to-install compact modules in any length up to  $L_{max}$
- ▶ Driven by precision ball screw assembly in rolled design tolerance grade T7 in accordance with DIN 69051 with single nut set to zero-clearance
- ▶ High travel speeds thanks to large leads with high precision over long lengths
- ▶ Aluminum carriages available in different lengths
- ▶ Protection of installation elements through a cover plate and two cover strips; optionally increased protection thanks to "Resist" cover
- ▶ Low-cost maintenance
- ▶ Repeatability of up to  $\pm 0.005$  mm

### Further highlights

- ▶ Flexible thanks to selectable options
- ▶ Centering holes for simple combination with other linear motion systems and connection elements
- ▶ Extensive accessories for connection and clamping units
- ▶ Nameplate with parameters for easy commissioning

### Attachments

- ▶ Motor attachments with flange and coupling or via a belt side drive
- ▶ Motor attachment kits according to customer specification
- ▶ Maintenance-free servo motors with selectable brake and attached feedback
- ▶ Magnetic sensors, switch activation without additional switching cam
- ▶ Socket and connector
- ▶ Cable duct made of aluminum for sensors

### Design/options for guideway (frame), carriages, connection plates

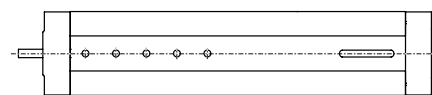
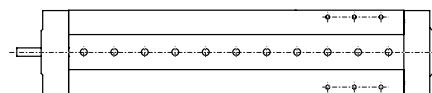
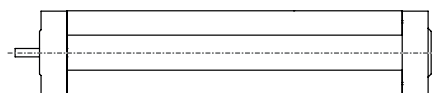

Guideway (frame)

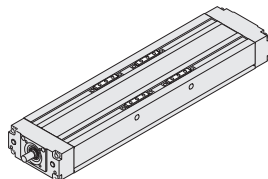
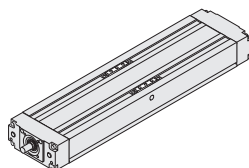

Carriages

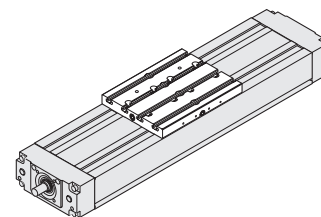

Connection plates

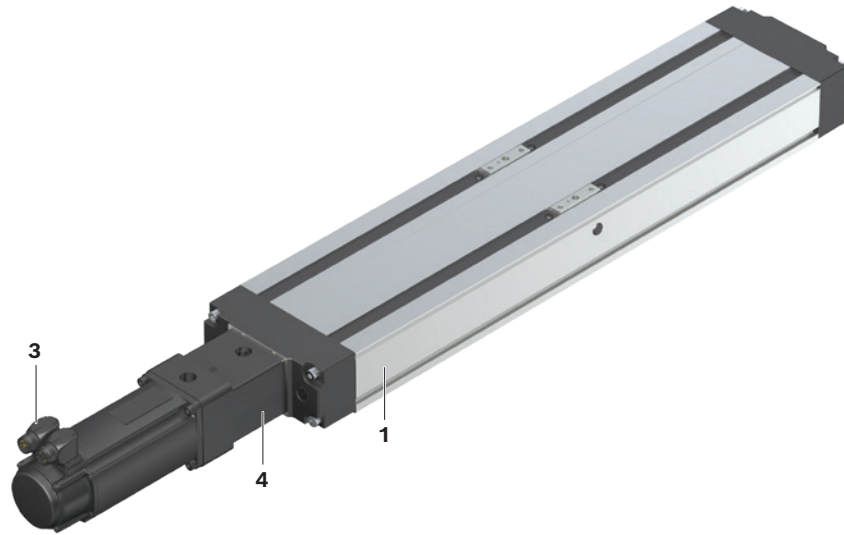

**Flange and coupling (MF01)**

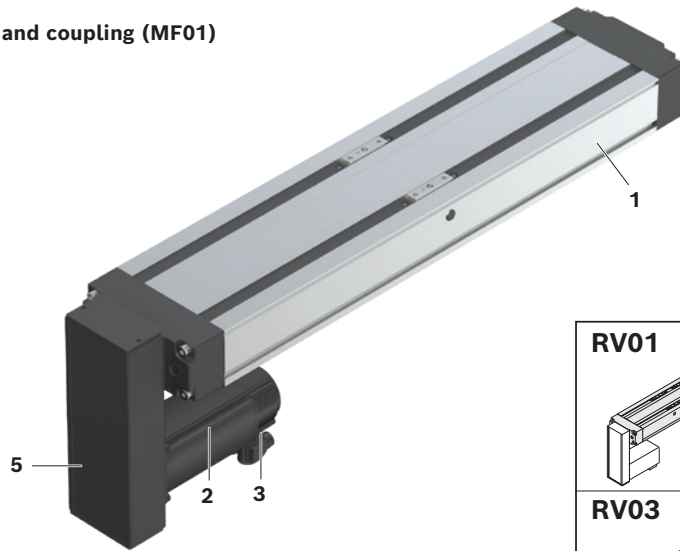

**Belt side drive (RV01-RV04)**

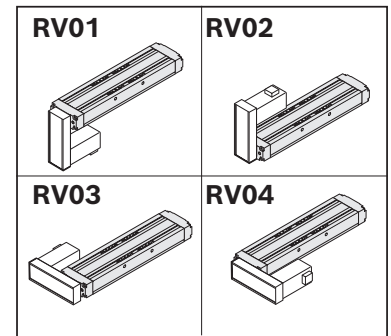

- 1 Linear motion system
- 2 Motor
- 3 Motor connector
- 4 Flange and coupling
- 5 Belt side drive

#### Screw support for compact module CKK-200

**Structural design:**

- ▶ Guidance of the screw supports in the frame.

**Features:**

- ▶ High speed over longer lengths of up to 5,500 mm.
- ▶ Elastomer buffer provides cushioning between carriage and screw supports.
- ▶ Screw supports are maintenance-free.
- ▶ Screw supports are protected by the cover plate and two cover strips.
- ▶ The screw supports prevent the cover plate from sagging in all directions.

 **Screw support suitable for horizontal operation only**

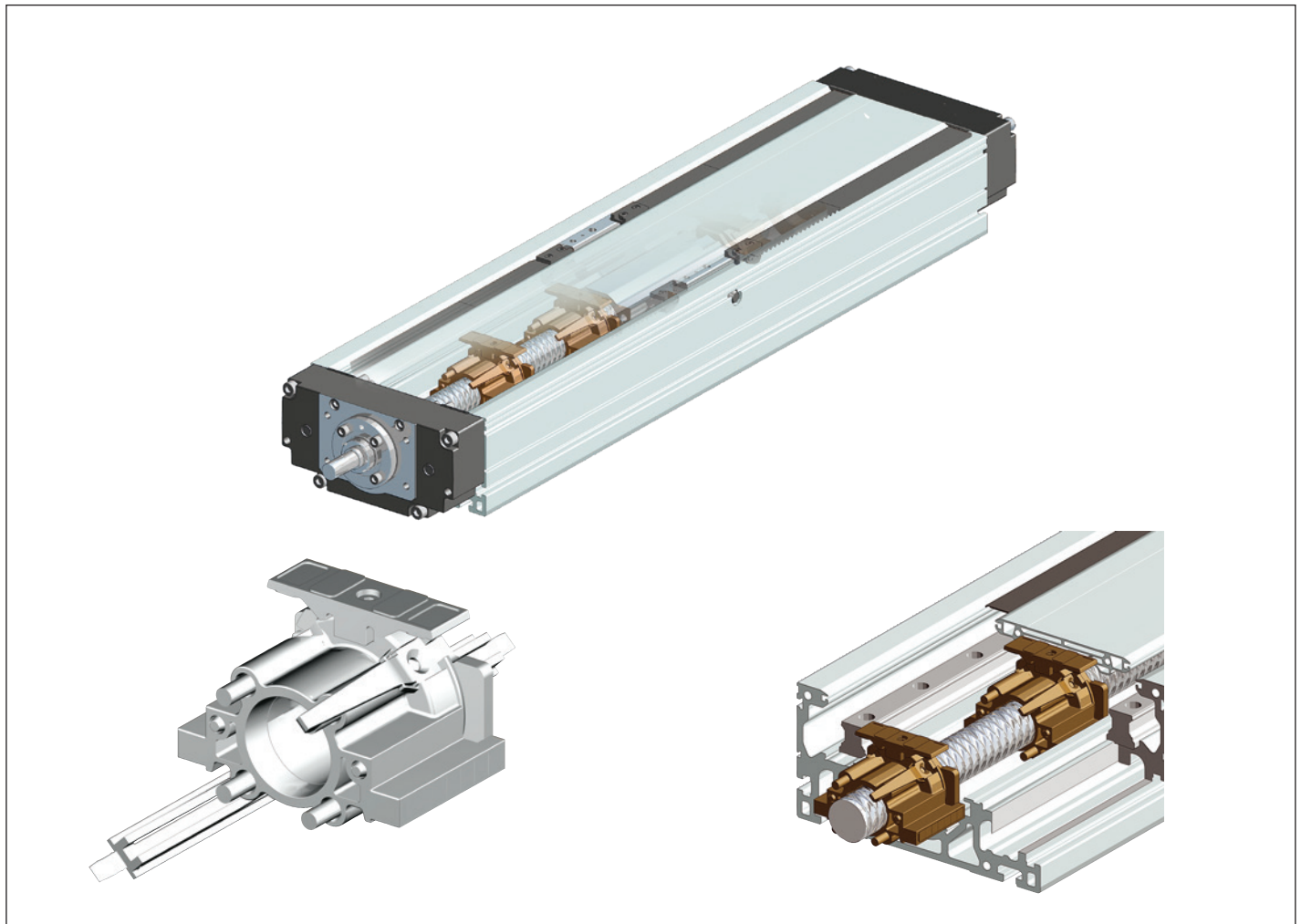



**"Resist" cover**

**Structural design:**

- ▶ Sizes: CKK -110, -145, -200
- ▶ Possible for version with connection plate

**Features:**

- ▶ Increased protection thanks to the toothed sealing profile
- ▶ The integrated guideway on the carriage ensures the sealing profile interlocks perfectly
- ▶ Sealing profile made of flexible FKM – material
- ▶ Free of LABS (substances harmful to paint structure)
- ▶ Replaceable sealing profile
- ▶ The sealing profile has a short-term temperature resistance of up to 300°C
- ▶ Suitable for exposure to dry chips with broken chips of aluminum and component handling during welding application
- ▶ Selectable with all lube versions

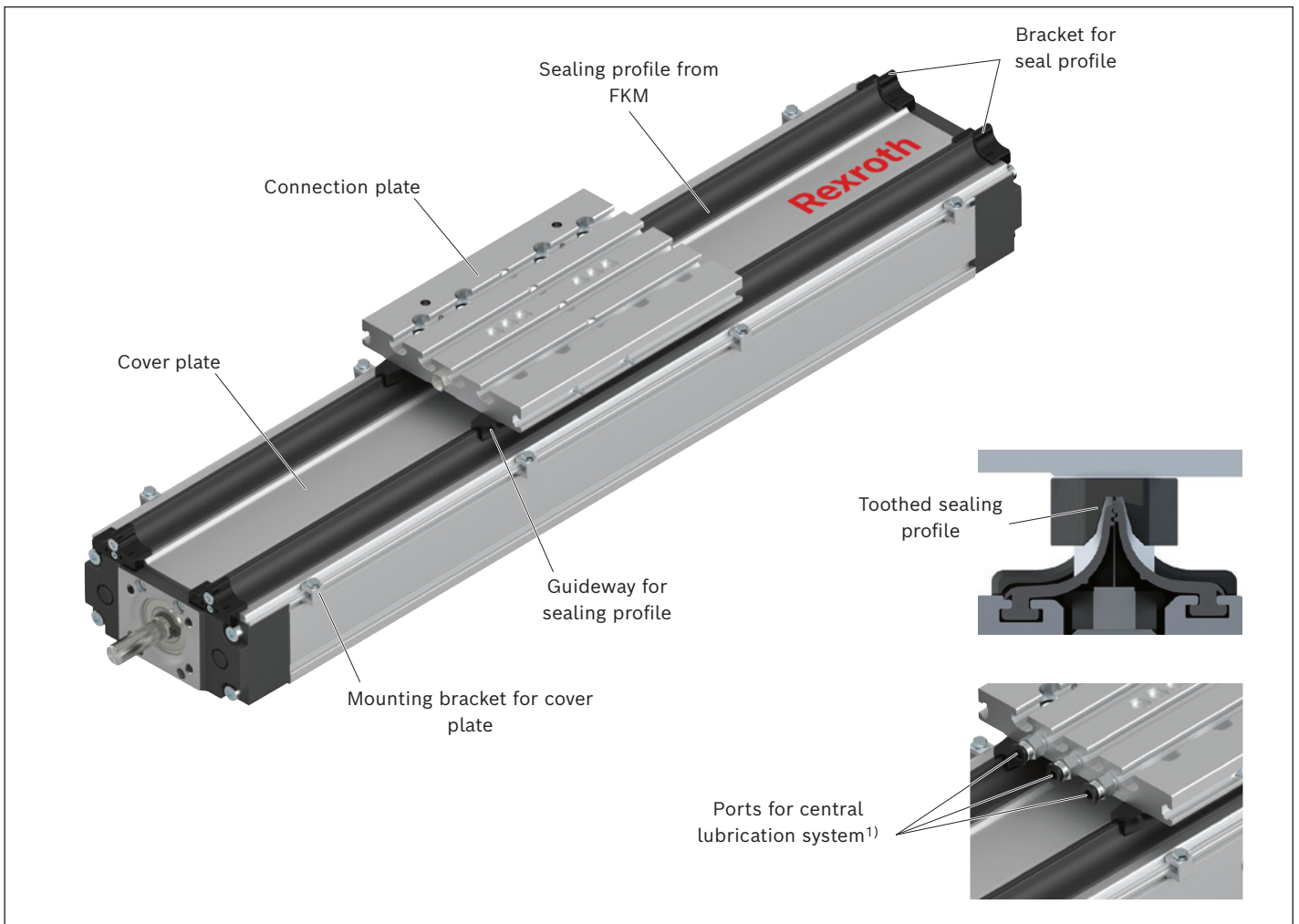

<sup>1)</sup> See chapter "Lubrication"

## Structural design

### Structural design CKK

- 1 Ball screw assembly with zero-backlash single nut
- 2 Drive side cross tie
- 3 Carriage with integrated runner block
- 4 Cover plate
- 5 Cover strip made of reinforced strip PU
- 6 End block
- 7 Frame

#### Attachments:

- 8 Connection plate
- 9 Magnetic sensor
- 10 Cable duct
- 11 Socket/connector
- 12 Flange and coupling
- 13 Belt side drive
- 14 Motor

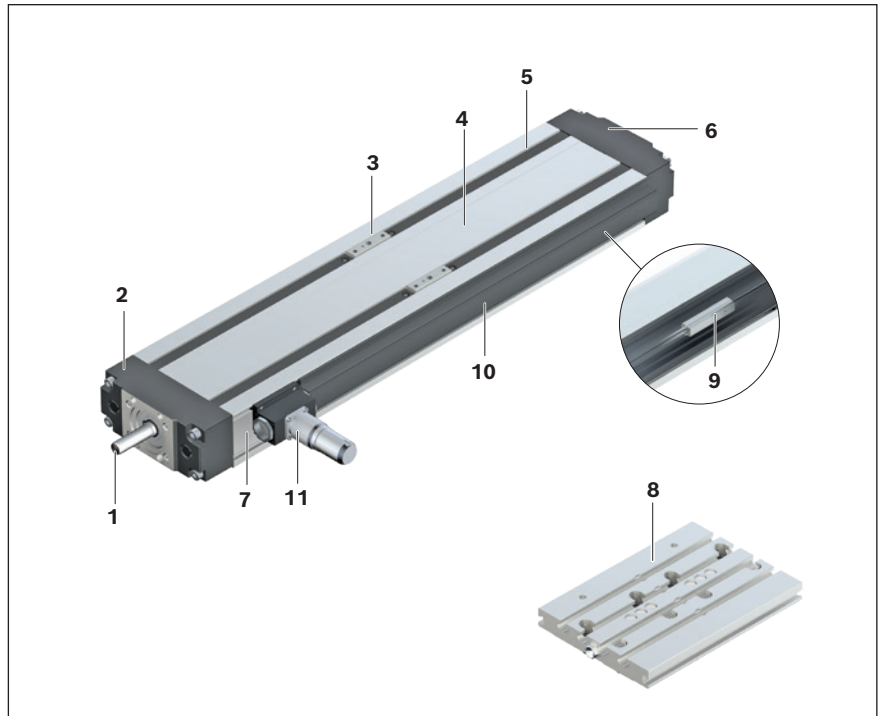

Motor attachment – flange and coupling

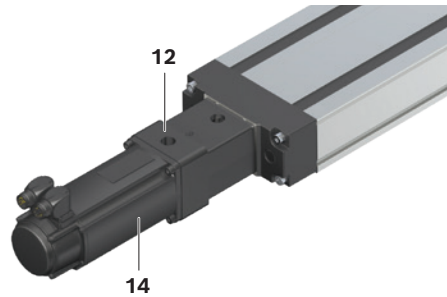

Motor attachment – belt side drive

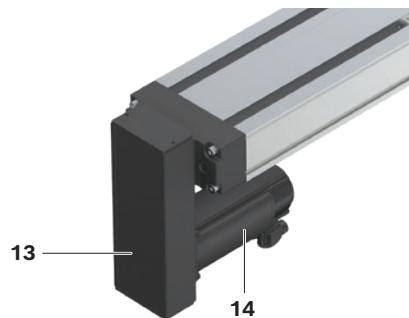

**Structure of flange and coupling**

A motor can be attached to all compact modules with ball screw assembly by means of a flange and coupling.

The flange serves to fasten the motor to the compact module and acts as a closed housing for the coupling. The motor's drive torque is transmitted stress-free through the coupling to the compact module's drive journal.

Our standard couplings compensate for the system's thermal expansion.

- 1 Motor
- 2 Flange
- 3 Coupling
- 4 Compact module

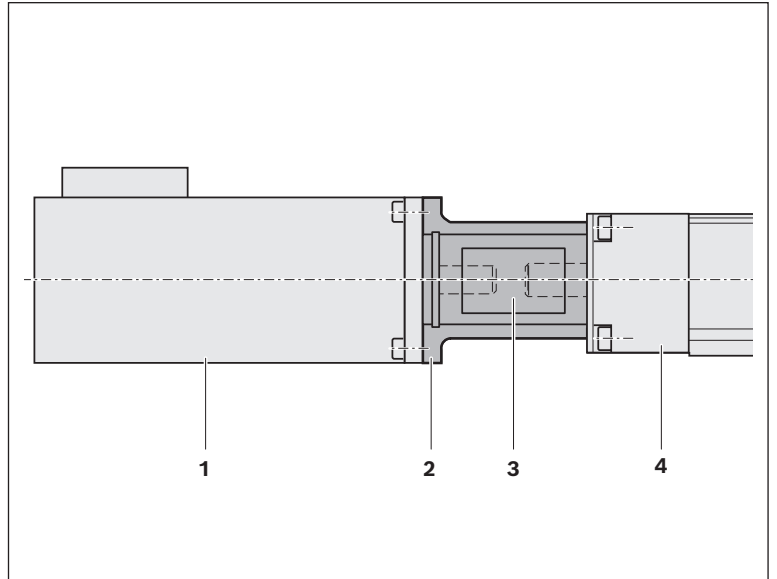

**Structure of belt side drive**

All compact modules with ball screw assembly offer the option of attaching the motor via a belt side drive. This makes the overall length shorter than when attaching the motor with flange and coupling. The space-saving, closed pulley housing serves as protection for the belt and as a motor bracket. In addition, various gear ratios are also available (depending on size):

- ▶  $i = 1$
- ▶  $i = 1.5$
- ▶  $i = 2$

The belt side drive can be mounted in four different directions:

- ▶ Below, above (RV01 and RV02)
- ▶ Left, right (RV03 and RV04)

- 1 Pulley housing made of anodized aluminum frame
- 2 Compact module
- 3 Support bearing at the screw journal in size CKK-070
- 4 Toothed belt drive
- 5 Motor
- 6 Toothed belt drive
- 7 Cover
- 8 Belt pulleys with tensioning units
- 9 Cover plate

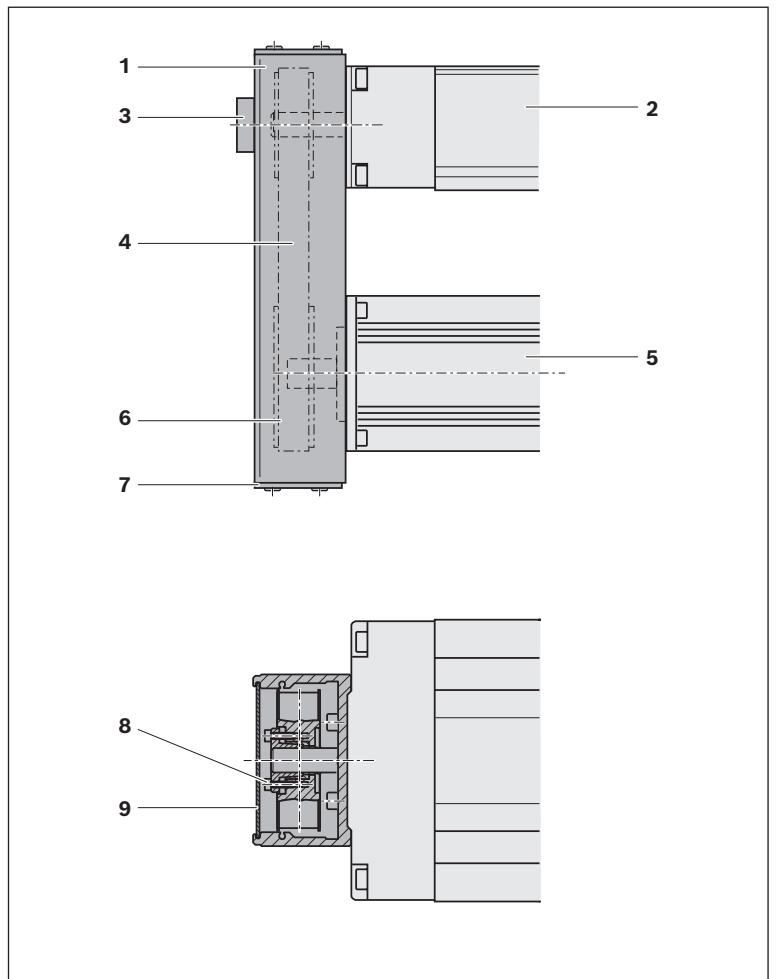

Technical data

**General technical data**

Observe the "Project planning/calculation" chapter.

CKK	Carriage			Additional length		Min. travel range	Max. length	BASA	Dynamic characteristic values									
	Connection plate		$L_W^{3)}$	Connection plate					Load capacities			Load moments						
	without <sup>1)</sup>	with <sup>2)</sup>		without	with	$s_{min}^{4)}$	$L_{max}$	$d_0 \times P$	$C_{gw}$	$C_{bs}$	$C_{fb}$	$M_t$	$M_L^{5)}$					
(mm)	(mm)	(mm)	(mm)	(mm)	(mm)	(mm)	(mm)	(N)	(N)	(N)	(Nm)	(Nm)						
<b>-070</b>	32	60	-	30	2	40	650	8 x 2.5	2,360	2 250	1 600	47	7					
					8			8 x 5		2500								
	73	95			8			8 x 2.5	2 250	3,830		77	111					
								8 x 5	2500									
<b>-090</b>	35	60	-	50	25	40	750	12 x 2	4,620	2,420	6,900	125	16					
										12 x 5				4,100				
										12 x 10				2,700				
	100	125			-		50	25	40	750	12 x 2	7,505	2,420	6,900	203	244		
													12 x 5				4,100	
													12 x 10				2,700	
	variable	-			variable		50	-		40	750	12 x 2	7,505	2,420	6,900	203	3.75 x $L_W$	
	min. 101				min. 66							12 x 5		4,100				
max. 235		max. 200	12 x 10	2,700														
<b>-110</b>	39	60	-	51	30	50	1,500	16 x 5			19,720	13,320	13,400	651	136			
												16 x 10				10,350		
									16 x 16			6,800						
	124	155			85		51	20	50		1,500	16 x 5	32,035	13,320	13,400	1,057	1,361	
														16 x 10				10,350
												16 x 16		6,800				
	variable	-			variable			51		-	50	1,500	16 x 5	32,035	13,320	13,400	1,057	16.01 x $L_W$
	min. 125				min. 86								16 x 10		10,350			
max. 289		max. 250	16 x 16	6,800														
<b>-145</b>	49	80	-	61	30	60		1,800		20 x 5		46,800	15,480	17,000	2,059	400		
													20 x 20				9,810	
									20 x 40	12,600								
									25 x 10	16,920								
	149	190		100	61		20	60	1,800	20 x 5		76,025	15,480	17,000	3,345	3,801		
											20 x 20		9,810					
											20 x 40		12,600					
											25 x 10		16,920					
	variable	-		variable	61		-		60	1,800	20 x 5	76,025	15,480	17,000	3,345	38.01 x $L_W$		
	min. 150			min. 101							20 x 20		9,810					
	max. 349			max. 300							20 x 40		12,600					
											25 x 10		16,920					
<b>-200</b>	79.5	190	-	120.5	10	80	2,200			32 x 5	74,600	23,310	26,000	4,849	1,053			
												32 x 10				34,200		
												32 x 20				21,240		
												32 x 32				21,060		
	254.5	305		175	120.5		70	80		2,200	32 x 5	121,185	23,310	26,000	7,877	10,604		
													32 x 10				34,200	
													32 x 20				21,240	
													32 x 32				21,060	
	variable	-		variable	120.5		-		80	2,200	32 x 5	121,185	23,310	26,000	7,877	60.59 x $L_W$		
	min. 255.5			min. 176							32 x 10		34,200					
	max. 429.5			max. 350							32 x 20		21,240					
											32 x 32		21,060					

1) In the "without connection plate" version, carriage length  $L_{ca}$  corresponds to the dimension of the outer edge to outer edge of the fastening bridges. Dynamic characteristic values and maximum permissible loads are valid only when connecting the fastening bridges via customer-built attachment.

2) The connection plate is mounted on the "without connection plate" carriage version. In the "with connection plate" version, carriage length  $L_{ca}$  corresponds to the length of the connection plate.

3) A variable center-to-center distance  $L_W$  is only possible for the "without connection plate" carriage design. The variable center-to-center distance is freely selectable between minimum and maximum distance in millimeters steps.

Maximum permissible loads							Planar moments of inertia		Point of force application	
Moments			Forces				$L_y$ (cm <sup>4</sup> )	$L_z$ (cm <sup>4</sup> )	Connection plate	
$M_{x \max}$ (Nm)	$M_{y \max}^{5)}$ (Nm)	$M_{z \max}^{5)}$ (Nm)	$F_{y \max}$ (N)	$F_{z1 \max}$ (N)	$F_{z2 \max}$ (N)	without $Z_1$ (mm)			with $Z_1$ (mm)	
47	7	7	1,270	2,360	2,360	5,72	50,0	19.2	31.7	
77	111	60	2070	3830	3830					
112	16	16	2,490	4,620	4,140	14,80	140,2	23.2	39.2	
203	244	132	4,050	7,505	7,505					
203	3.75 x L <sub>W</sub>	2.03 x L <sub>W</sub>	4,050	7,505	7,505					
198	32	32	3,480	6,000	6,000	38,90	361,7	26.7	42.7 (60.7) <sup>6)</sup>	
396	510	240	5,650	12,000	12,000					
396	6 x L <sub>W</sub>	2.82 x L <sub>W</sub>	5,650	12,000	12,000					
634	100	100	8,410	14,400	14,400	125,50	1,148.0	31.6	51.6 (71.6) <sup>6)</sup>	
1,267	1,440	683	13,660	28,800	28,800					
1,267	14.4 x L <sub>W</sub>	6.83 x L <sub>W</sub>	13,660	28,800	28,800					
1,375	299	299	12,265	21,150	21,150	551,00	3,895.0	36.0	63.0 (86.4) <sup>6)</sup>	
2,750	3,701	1,744	19,925	42,300	42,300					
2,750	21.14 x L <sub>W</sub>	9.97 x L <sub>W</sub>	19,925	42,300	42,300					

4) Minimum required travel range to ensure a reliable lubrication distribution.

5) For the variable L<sub>W</sub>, M<sub>L</sub>, M<sub>y max</sub> and M<sub>z max</sub> must be determined according to the selected centerline-to-centerline distance L<sub>W</sub>.

6) "Resist" cover → "Resist" chapter.

**Drive data**

Observe the "Project planning/calculation" chapter.

CKK	BASA	Carriage		Constant weight calculation		Moved mass of system	
		Connection plate without	with	$k_{g \text{ fix}}$ (kg)	$k_{g \text{ var}}$ (kg/mm)	Connection plate without <sup>1)</sup>	with
	$d_0 \times P$ (mm)	$L_{ca}$ (mm)	$L_{ca}$ (mm)			$m_{ca}$ (kg)	$m_{ca}$ (kg)
<b>-070</b>	8 x 2.5	32	60	0.29	0.0038	0.15	0.26
		73	95			0.25	0.42
	8 x 5	32	60			0.15	0.26
		73	95			0.25	0.42
<b>-090</b>	12 x 2	35	60	0.50	0.0054	0.36	0.54
		100	125			0.59	0.96
	12 x 5	35	60			0.36	0.54
		100	125			0.59	0.96
	12 x 10	35	60			0.36	0.54
		100	125			0.59	0.96
<b>-110</b>	16 x 5	39	60	0.91	0.0094	0.52	0.75
		124	155			0.86	1.45
	16 x 10	39	60			0.52	0.75
		124	155			0.86	1.45
	16 x 16	39	60			0.52	0.75
		124	155			0.86	1.45
<b>-145</b>	20 x 5	49	80	1.91	0.0179	1.21	1.71
		149	190			2.06	3.26
	20 x 20	49	80			1.21	1.71
		149	190			2.06	3.26
	20 x 40	49	80			1.21	1.71
		149	190			2.06	3.26
	25 x 10	49	80			1.21	1.71
		149	190			2.06	3.26
<b>-200</b>	32 x 5	79.5	190	4.06	0.0296	3.20	5.50
		254.5	305			5.20	8.90
	32 x 10	79.5	190			3.20	5.50
		254.5	305			5.20	8.90
	32 x 20	79.5	190			3.20	5.50
		254.5	305			5.20	8.90
	32 x 32	79.5	190			3.20	5.50
		254.5	305			5.20	8.90

<sup>1)</sup> To the carriage version with variable center-to-center distance  $L_w$ , the larger value applies

	Constant mass moment of inertia				Friction torque <sup>1)</sup>	Max. acceleration	Max. speed	Max. drive torque
	Connection plate		$k_{J\ var}$ (kg/mm)	$k_{J\ m}$ (mm <sup>2</sup> )				
	without <sup>1)</sup>	with						
	$k_{J\ fix}$ (kg/mm <sup>2</sup> )	$k_{J\ fix}$ (kg/mm <sup>2</sup> )						
	0.769	0.786	0.004	0.158	0.07	50.0	See "Diagrams" chapter	See "Diagrams" chapter
	0.785	0.812						
	0.840	0.910						
	0.903	1.011						
	1.279	1.298	0.013	0.101	0.13	48.4	See "Diagrams" chapter	See "Diagrams" chapter
	1.303	1.340			0.14			
	1.454	1.568	0.011	0.633	0.15	50.0		
	1.599	1.834			0.16			
	2.138	2.594	0.011	2.533	0.18	50.0		
	2.720	3.658			0.20			
	5.088	5.234	0.031	0.633	0.37	50.0		
	5.303	5.677			0.40			
	6.076	6.658	0.031	2.533	0.40	50.0		
	6.937	8.432			0.43			
	8.161	9.652	0.034	6.485	0.42	50.0		
	10.365	14.191			0.48			
	22.564	22.880	0.084	0.633	0.48	39.8		
	23.102	23.862			0.52			
	34.029	39.950	0.081	10.132	0.60	50.0		
	42.641	54.800			0.68			
	70.856	91.120	0.086	40.528	0.70	50.0		
	105.305	153.939			0.86			
	26.335	27.601	0.239	2.533	0.60	50.0		
	28.488	31.528			0.65			
	71.348	72.867	0.605	0.633	1.10	17.9		
	72.741	75.147			1.20			
	76.612	82.691	0.640	2.533	1.10	30.7		
	82.185	91.810			1.20			
	93.299	117.676	0.639	10.132	1.15	50.0		
	115.590	154.092			1.25			
	127.391	189.642	0.617	25.938	1.25	50.0		
	184.455	283.020			1.35			

Technical data for CKK-200 with screw support

**General technical data**

Observe the "Project planning/calculation" chapter.

CKK	Carriage		BASA	SPU	Additional length			Max. length	Min. travel range	Dynamic characteristic values					
	Connection plate without <sup>1)</sup>	Connection plate with <sup>2)</sup>			d <sub>0</sub> x P (mm)	L <sub>ad</sub> (mm)	L <sub>ad</sub> (mm)			L <sub>max</sub> (mm)	Load capacities			Load moments	
											L <sub>ca</sub> (mm)	L <sub>ca</sub> (mm)	S <sub>min</sub> <sup>3)</sup> (mm)	C <sub>gw</sub> (N)	C <sub>bs</sub> (N)
-200	79.5	190	32 x 5	0	120.5	10	2,200	80	74,600	26,000	4,849	1,053	23,310		
				1	235.5	-	3,500								
				2	360.5	-	4,600								
				3	485.5	-	5,500								
			32 x 10	0	120.5	10	2,200								
				1	235.5	-	3,500								
				2	360.5	-	4,600								
				3	485.5	-	5,500								
			32 x 20	0	120.5	10	2,200								
				1	235.5	-	3,500								
				2	360.5	-	4,600								
				3	485.5	-	5,500								
	32 x 32	0	120.5	10	2,200										
		1	235.5	-	3,500										
		2	360.5	-	4,600										
		3	485.5	-	5,500										
	254.5	305	32 x 5	0	120.5	70	2,200	80	121,185	26,000	7,877	10,604	23,310		
				1	235.5	185	3,600								
				2	360.5	310	4,700								
				3	485.5	435	5,500								
			32 x 10	0	120.5	70	2,200								
				1	235.5	185	3,600								
				2	360.5	310	4,700								
				3	485.5	435	5,500								
			32 x 20	0	120.5	70	2,200								
				1	235.5	185	3,600								
				2	360.5	310	4,700								
				3	485.5	435	5,500								
32 x 32			0	120.5	70	2,200									
			1	235.5	185	3,600									
			2	360.5	310	4,700									
			3	485.5	435	5,500									

<sup>1)</sup> In the "without connection plate" version, carriage length L<sub>ca</sub> corresponds to the dimension of the outer edge to outer edge of the fastening bridges. Dynamic characteristic values and maximum permissible loads are valid only when connecting the fastening bridges via customer-built attachment.

<sup>2)</sup> The connection plate is mounted on the "without connection plate" carriage version. In the "with connection plate" version, carriage length L<sub>ca</sub> corresponds to the length of the connection plate.

<sup>3)</sup> Minimum required travel range to ensure a reliable lubrication distribution.



Maximum permissible loads							Constants		Planar moments of inertia		Point of force application	
Moments			Forces				Mass calculation		$I_y$ (cm <sup>4</sup> )	$I_z$ (cm <sup>4</sup> )	Connection plate	
$M_x$ max (Nm)	$M_y$ max (Nm)	$M_z$ max (Nm)	$F_y$ max (N)	$F_{z1}$ max (N)	$F_{z2}$ max (N)	$k_g$ fix (kg)	$k_g$ var (kg/mm)	$Z_1$ (mm)			without	with
1,375	299	299	12,265	21,150	21,150	4.06	0.0296	551	3,895	36.0	63.0	
2,750	3,701	1,744	19,925	42,300	42,300	4.06	0.0296	551	3,895	36.0	63.0	

**Drive data**

Observe the "Project planning/calculation" chapter.

CKK	BASA	SPU	Carriage Connection plate		Constant mass calculation		Moved mass of system Connection plate	
			without L <sub>ca</sub> (mm)	with L <sub>ca</sub> (mm)	k <sub>g</sub> fix (kg)	k <sub>g</sub> var (kg/mm)	without <sup>1)</sup> m <sub>ca</sub> (kg)	with m <sub>ca</sub> (kg)
<b>-200</b>	32 x 5	0	79.5	190	4.06	0.0296	3.20	5.50
		1					3.40	-
		2					3.60	-
		3					3.80	-
		0	254.5	305			5.20	8.90
		1					5.40	9.10
		2					5.60	9.30
		3					5.80	9.50
	32 x 10	0	79.5	190			3.20	5.50
		1					3.40	-
		2					3.60	-
		3					3.80	-
		0	254.5	305			5.20	8.90
		1					5.40	9.10
		2					5.60	9.30
		3					5.80	9.50
	32 x 20	0	79.5	190			3.20	5.50
		1					3.40	-
		2					3.60	-
		3					3.80	-
		0	254.5	305			5.20	8.90
		1					5.40	9.10
		2					5.60	9.30
		3					5.80	9.50
	32 x 32	0	79.5	190			3.20	5.50
		1					3.40	-
		2					3.60	-
		3					3.80	-
0		254.5	305	5.20	8.90			
1				5.40	9.10			
2				5.60	9.30			
3				5.80	9.50			

<sup>1)</sup> To the carriage version with variable center-to-center distance L<sub>w</sub>, the larger value applies

	Constant mass moment of inertia				Friction torque <sup>1)</sup>	Max. acceleration	Max. speed	Max. drive torque
	Connection plate		$k_{J \text{ var}}$ (kg/mm)	$k_{J \text{ m}}$ (mm <sup>2</sup> )				
without <sup>1)</sup>	with	$k_{J \text{ fix}}$ (kg/mm <sup>2</sup> )			$k_{J \text{ fix}}$ (kg/mm <sup>2</sup> )			
	71.348	72.867	0.605	0.633	1.10	17.9	See "Diagrams" chapter	See "Diagrams" chapter
	71.474	-			1.20			
	71.601	-			1.20			
	71.728	-			1.40			
	72.741	75.147	0.605	0.633	1.20			
	72.867	75.274			1.30			
	72.994	75.400			1.30			
	73.121	75.527			1.50			
	76.612	82.691	0.640	2.533	1.10	30.7	See "Diagrams" chapter	
	77.119	-			1.20			
	77.625	-			1.40			
	78.132	-			1.50			
	82.185	91.810	0.640	2.533	1.20			
	82.691	92.317			1.30			
	83.198	92.823			1.50			
	83.705	93.330			1.60			
	93.299	117.616	0.639	10.132	1.15	50.0	See "Diagrams" chapter	
	95.326	-			1.30			
	97.352	-			1.50			
	99.378	-			1.70			
	115.590	154.092	0.639	10.132	1.25			
	117.676	156.118			1.40			
	119.643	158.145			1.60			
	121.669	160.171			1.80			
	127.391	189.642	0.617	25.938	1.25	50.0	See "Diagrams" chapter	
	132.578	-			1.40			
	137.766	-			1.70			
	142.953	-			1.90			
	184.455	283.020	0.617	25.938	1.35			
	189.642	288.207			1.50			
	194.830	293.395			1.80			
	200.018	298.583			2.00			

Technical data

**Drive data for motor attachment via belt side drive**

Observe the "Project planning/calculation" chapter.

CKK	Motor	BASA (mm) d <sub>0</sub> x P	up to L <sup>1)</sup> (mm)	M <sub>sd</sub> <sup>2)</sup> (Nm)		J <sub>sd</sub> (10 <sup>-6</sup> kgm <sup>2</sup> )		M <sub>Rsd</sub> (Nm)	m <sub>sd</sub> (kg)		B <sub>t</sub>	
				i = 1	i = 1.5	i = 1	i = 1.5		i = 1	i = 1.5	i = 1	i = 1.5
<b>-070</b>	MSM019B	8 x 2.5	450	0.71	0.47	10.7	4.1	0.06	0.28	0.26	6 AT3	6 AT3
	MS2N03-B MSM031B	8 x 2.5	450	0.71	0.47	34.77	13.05	0.15	0.66	0.63	10 AT3	10 AT3
	MSM019B	8 x 5	450	1.31	0.87	10.7	4.1	0.06	0.28	0.26	6 AT3	6 AT3
	MS2N03-B MSM031B	8 x 5	450	1.41	0.94	34.77	13.05	0.15	0.66	0.63	10 AT3	10 AT3
	<b>-090</b>	MS2N03-B MSM031C	12 x 2	750	0.79	0.53	38.0	14.0	0.15	0.53	0.48	10 AT3
12 x 5			750	2.39	1.59							
12 x 10			750	2.73	1.82							
<b>-110</b>	MS2N03-B MSM031C	16 x 5	1,250	3.17	2.11	41.0	16.0	0.15	0.53	0.48	10 AT3	10 AT3
		16 x 10	1,500	3.17	2.11							
		16 x 16	1,500	3.17	2.11							
	MS2N04 MSM041B	16 x 5	850	6.76	4.51	240.0	82.0	0.40	1.34	1.24	16 AT5	16 AT5
		16 x 10	1,150	7.66	5.11							
		16 x 16	1,450	7.66	5.11							
<b>-145</b>	MS2N04 MSM041B	20 x 5	1,350	8.22	5.48	250.0	85.0	0.40	1.42	1.31	16 AT5	16 AT5
		20 x 20	1,800	8.22	5.48							
		20 x 40	1,800	8.22	5.48							
		25 x 10	1,800	8.22	5.48							

CKK	Motor	BASA (mm) d <sub>0</sub> x P	up to L <sup>1)</sup> (mm)	M <sub>sd</sub> <sup>2)</sup> (Nm)		J <sub>sd</sub> (10 <sup>-6</sup> kgm <sup>2</sup> )		M <sub>Rsd</sub> (Nm)	m <sub>sd</sub> (kg)		B <sub>t</sub>	
				i = 1	i = 2	i = 1	i = 2		i = 1	i = 2	i = 1	i = 2
<b>-145</b>	MS2N05	20 x 5	1,150	11.00	5.50	1,310	217	0.45	3.5	3.1	25 AT5	25 AT5
		20 x 20	1,800	17.73	8.87							
		20 x 40	1,800	17.73	8.87							
		25 x 10	1,800	17.73	8.87							
<b>-200</b>	MS2N06	32 x 5	2,200	19.00	9.50	1,400	260	0.50	3.8	3.5	25 AT5	32 AT5
		32 x 10	2,200	19.21	12.30							
		32 x 20	2,200	19.21	12.30							
		32 x 32	2,200	19.21	12.30							

<sup>1)</sup> For greater lengths, the permissible drive torque is determined from the length-variable value M<sub>p</sub> of the linear motion system in accordance with the graph → Chapter "Project planning/calculation"

<sup>2)</sup> Values for M<sub>sd</sub> do not factor in motor torque.

**Drive data for motor attachment via flange and coupling**

CKK	Motor	Coupling		Flange and coupling
		$M_{cN}$ (Nm)	$J_c$ ( $10^{-6}$ kgm <sup>2</sup> )	
<b>-070</b>	MS2N03-B	3.7	7.00	0.30
	MSM019B	1.9	2.10	0.15
	MSM031B	3.7	7.00	0.30
<b>-090</b>	MS2N03-B	13.0	12.20	0.30
	MSM031C	13.0	12.20	0.35
<b>-110</b>	MS2N03-B	13.0	12.20	0.45
	MS2N03-D	14.0	12.20	0.45
	MS2N04	14.0	12.20	0.60
	MSM031C	14.0	12.20	0.45
	MSM041B	29.4	42.29	0.65
<b>-145</b>	MS2N04	26.1	42.29	0.80
	MS2N05	26.1	42.29	1.00
	MSM041B	26.1	42.29	0.80
<b>-200</b>	MS2N06	50.0	210.00	1.80
	MS2N07	98.0	390.00	2.25

Diagrams

**Permissible drive torque**

The values shown for  $M_p$  apply under the following conditions:

- ▶ Screw journal without keyway
- ▶ No radial loads on screw journal

**⚠ Keep in mind the rated torque of the coupling being used! Keep in mind the minimum travel range  $s_{min}$ !**

**⚠ Screw journal with keyway**

For reasons of stress concentration and a reduction of the effective diameter, observe the maximum values for drive torque!

CKK	$M_p$ (Nm)
-110 / -145	No reduction
-200	48.6

**⚠ For ball screw assemblies with keyway, the smallest value from the diagrams and the table is valid.**

Example:

CKK-200	$(d_o \times P)$	
	32 x 32	32 x 10
Length (mm)	1,500	1,500
$M_p$ from diagram (Nm)	58.5	39.0
$M_p$ maximum (Nm)	48.6	48.6
Value for sizing	48.6	39.0

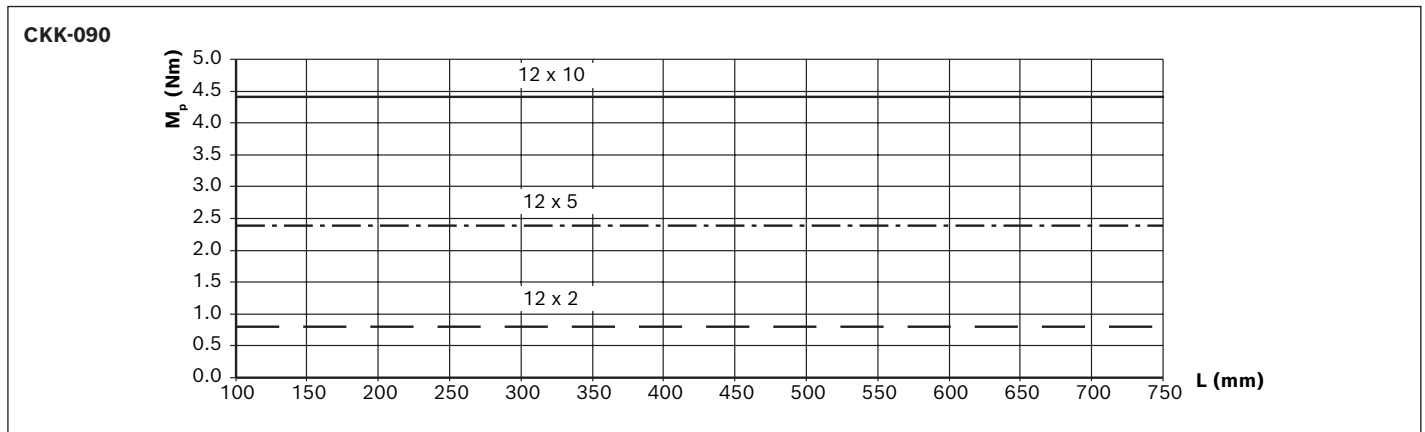
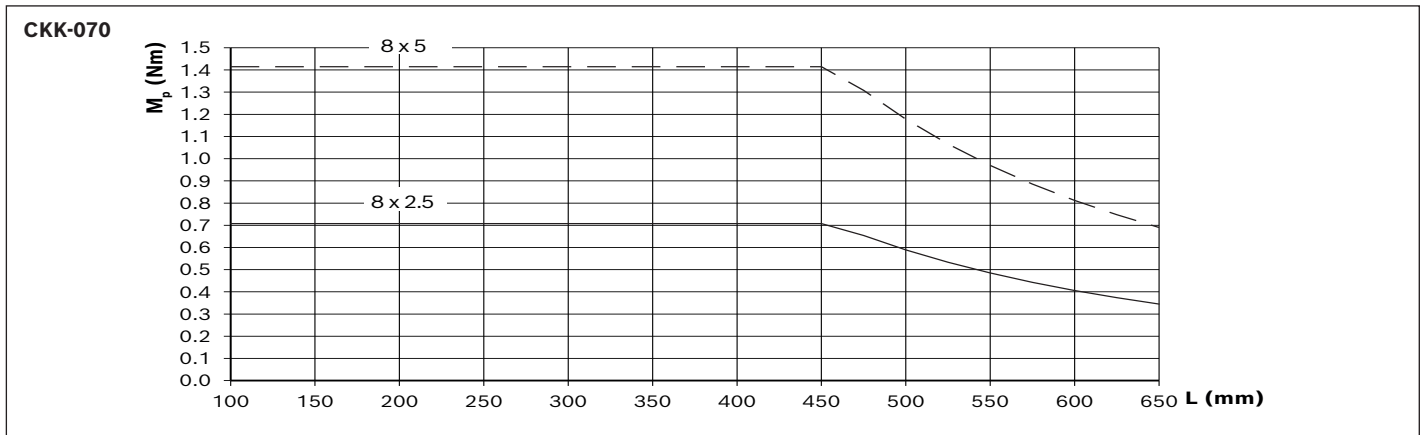

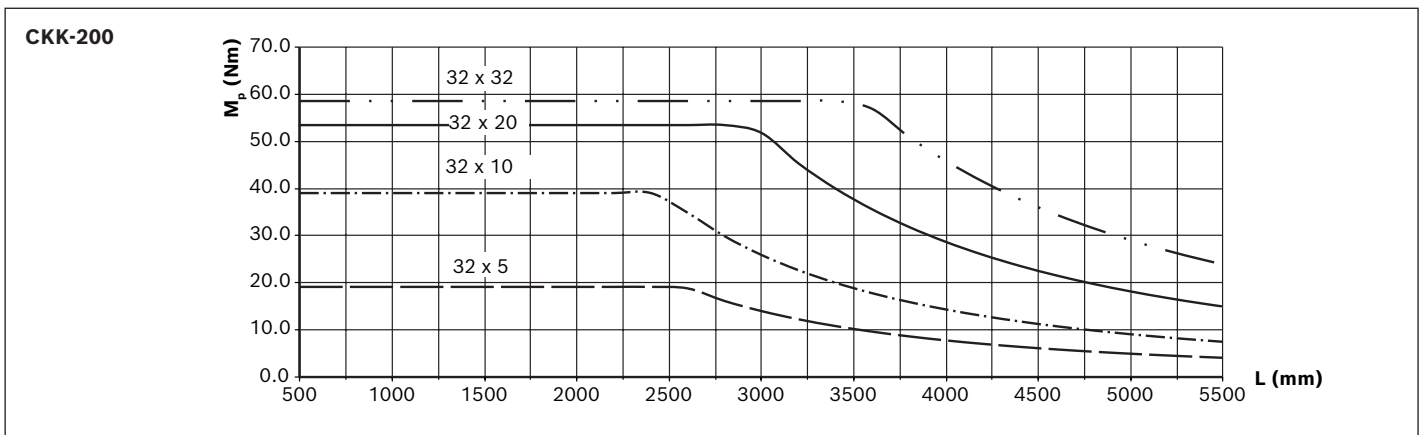
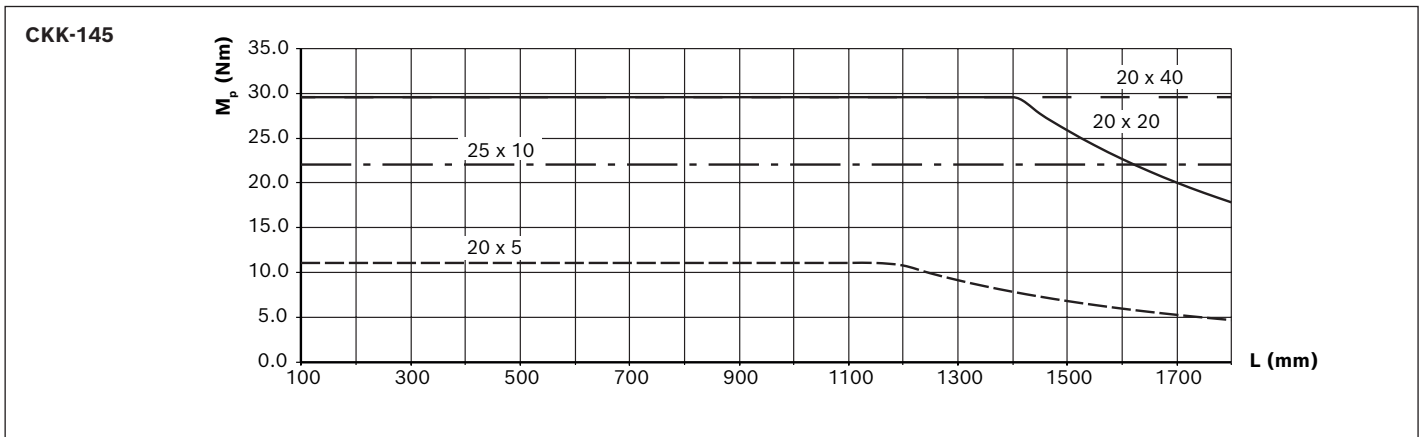
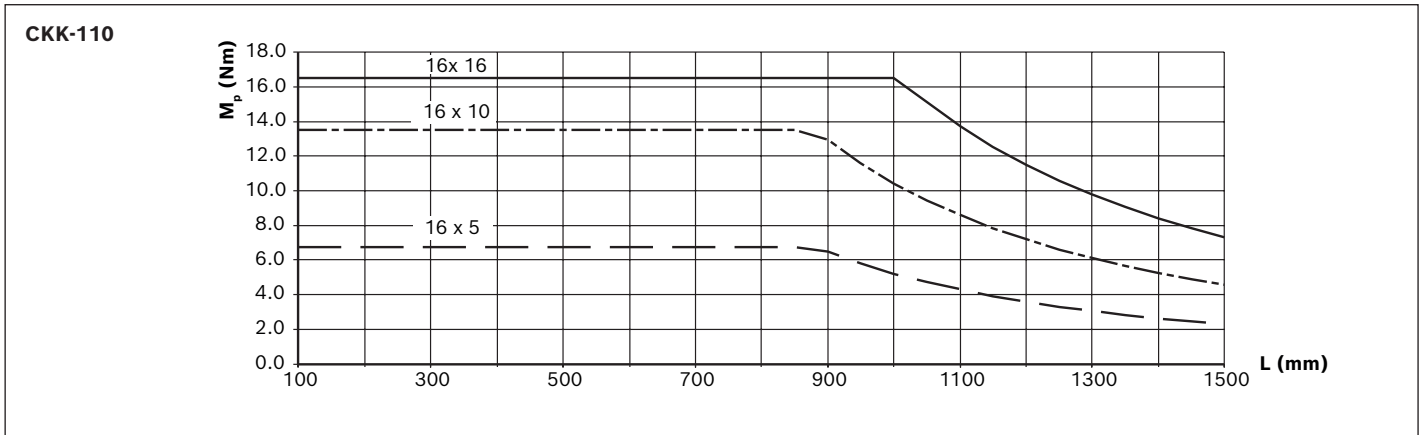

**Permissible speed**

Observe motor speed!

Keep in mind the minimum travel range  $s_{min}$ !

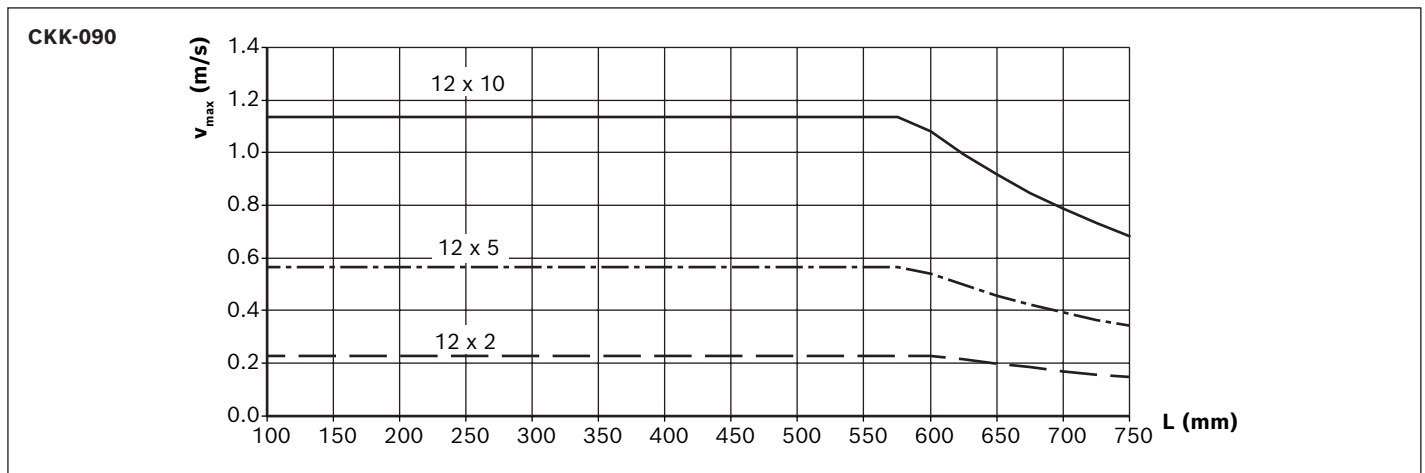
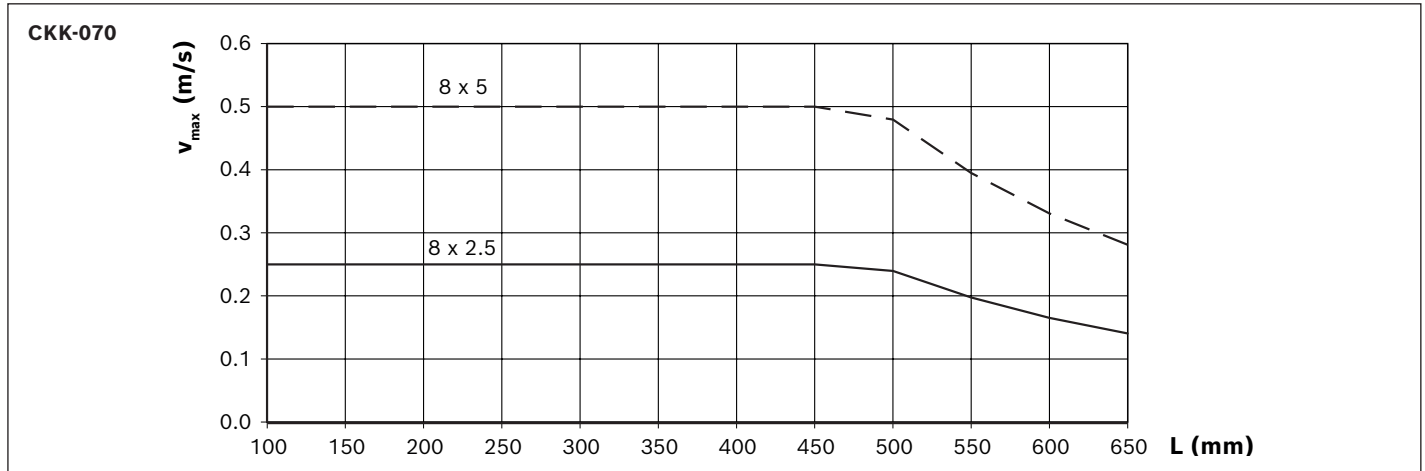



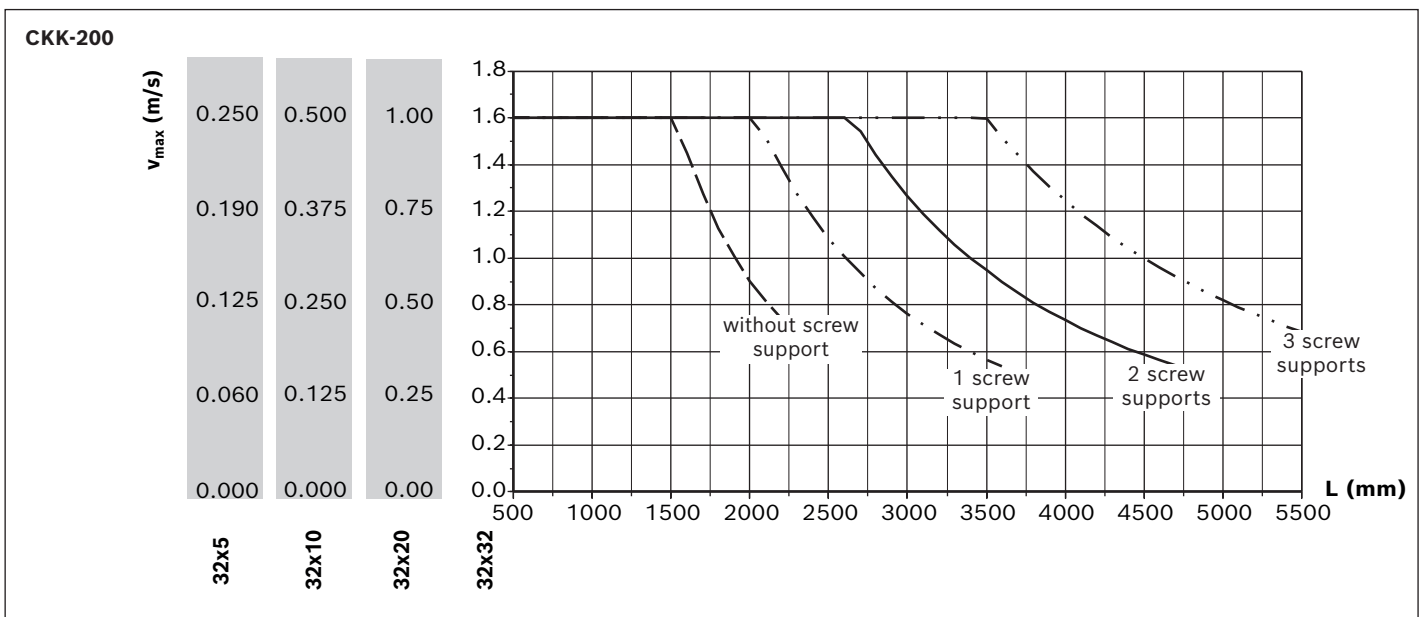
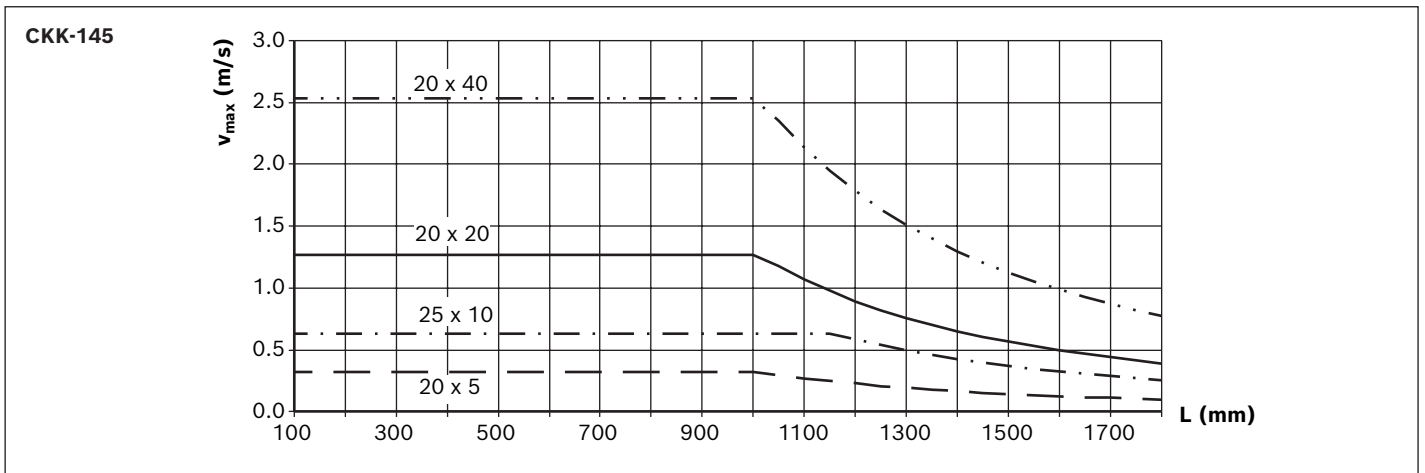
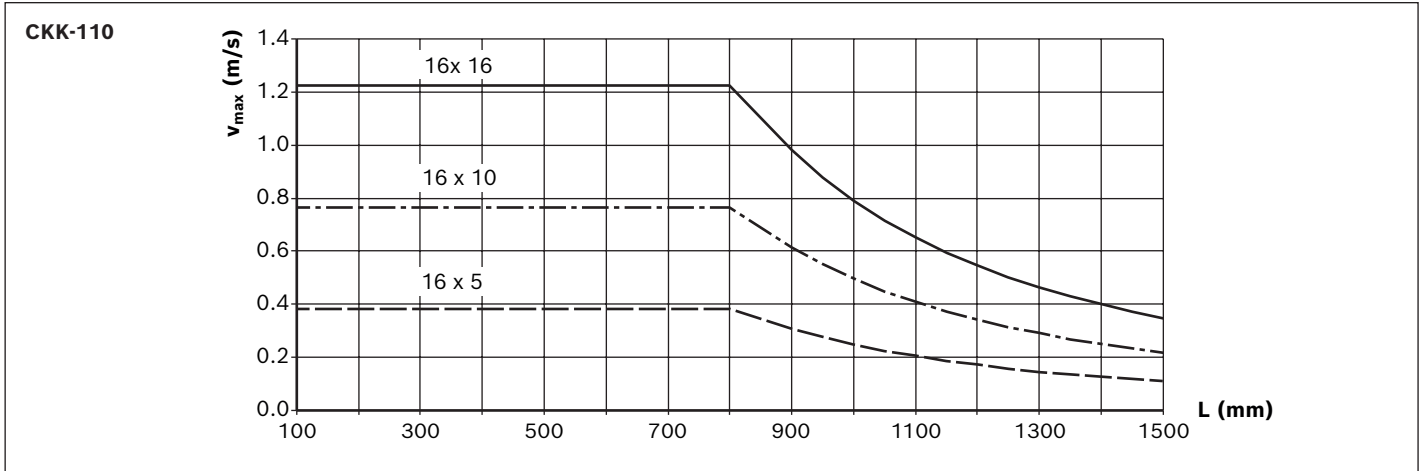





Configuration, order

**CKK-070**

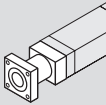
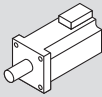
Short product name, length <sup>1)</sup> CKK-070-NN-1, ... mm		Guideway		Lubrication <sup>3)</sup>	Drive			Carriage				
		Standard	Centering holes <sup>2)</sup>		Screw journal (mm)	BASA d <sub>0</sub> x P (mm)		Connection plate without L <sub>ca</sub> (mm)		with L <sub>ca</sub> = (mm)		
Version							8 x 2.5	8 x 5	32	73	60	95
Without drive	OA01	01	03	04	LSS	-	050	050	01	02	40	41
	LPG				-				302	-	341	
Without attachment	OF01				LSS	∅6	01	02	01	02	40	41
Flange/ coupling	MF01				LPG	∅6	31	32	-	302	-	341
	RV01				RV02							
Belt side drive	RV03				RV04							

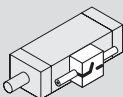
- 1) Length calculation of the linear motion system ⇒ "Project planning/calculation" chapter.
- 2) Centering holes for simple combination with other linear motion systems and connection elements (see dimension drawings).  
Option 03: with centering holes and fastening threads in the ground area of the frame  
Option 04: with centering holes and long hole in the ground area of the frame; selectable starting from length L ≥ 300 mm up to length L<sub>max</sub>
- 3) Lubrication ⇒ Chapter "Lubrication".
- 4) Attachment kit also available without motor. When ordering, enter the motor type "00"! Attachment kits according to customer specifications ⇒ Chapter "Attachment Kits for Motors according to Customer Specifications"
- 5) Recommended motor, motor data and type designations ⇒ Chapter "Motors"
- 6) More information ⇒ Chapter "Switching system"
- 7) Assembly contains 1 x sensor, 1 x switch mounting plate including set screws and square nuts as well as 3 x cable holders including set screws
- 8) Measurement report: 01 = standard report; 02 = Measurement of frictional torque; 03 = Lead deviation (see also "Documentation" chapter)

Motor attachment		Motor <sup>5)</sup>						Cover		Switching system <sup>6)</sup>		Automation package			Documentation <sup>8)</sup>	
																
i =	Attachment kit <sup>4)</sup>	Motor code		2 cables		1 cable		Motor connector position		Cover strip		Controller	Cable	Software		
				without brake	with brake	without brake	with brake	without	with	without	with					
OA01	-	00	-	00				-	01	Without		"Automation package" chapter		01		
	OF01										- Switch				00	
MF01	-	01	MS2N03-B0BYN	-	-	203	204	000	02	Magnetic sensor					02	
		03	MSM031B-0300	136	137	-	-			REED, changeover (NC: C+NC, NO: C+NO)	21					
		05	MSM019B-0300	134	135	-	-			Hall, PNP normally closed (NC)	22					
RV01 - RV04	1	17	MS2N03-B0BYN	-	-	203	204	090		Hall, PNP normally open (NO)	23				03	
		19	MSM031B-0300	136	137	-	-			Cable duct	25					
		15	MSM019B-0300	134	135	-	-			Socket-connector	28					
	1.5	18	MS2N03-B0BYN	-	-	203	204			Magnetic sensor with connector <sup>7)</sup>						58
		20	MSM031B-0300	136	137	-	-			REED, changeover (NC: C+NC, NO: C+NO)	58					
		16	MSM019B-0300	134	135	-	-			Hall, PNP normally closed (NC)	59					

Flange	Motor connector position			
	0°	90°	180°	270°
MF01	000	090 ★	180	270

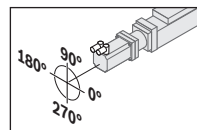

Example:  
Flange MF01  
Motor connector position 90°

Belt side drive	Motor connector position			
	0°	90°	180°	270°
RV01	000	-	180	270 ★
RV02	000	090 ★	180	-
RV03	000 ★	090	-	270
RV04	-	090	180 ★	270

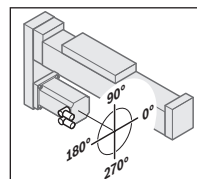

Example:  
Belt side drive RV01  
Motor connector position 180°



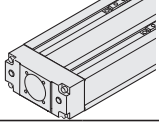
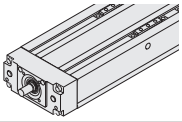
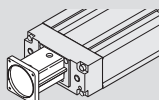
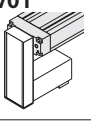
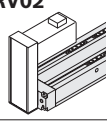
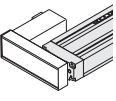
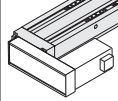

★ Standard delivery

Explanation of the order parameters and ordering example ⇒ Chapter "Ordering example".

**CKK-090**

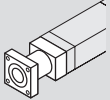
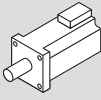
Short product name, length <sup>1)</sup> CKK-090-NN-1, ... mm		Guideway		Lubrication <sup>3)</sup>	Drive				Carriage					
		Standard	Centering holes <sup>2)</sup>		Screw journal (mm)	BASA d <sub>0</sub> x P (mm)			Connection plate without L <sub>ca</sub> = (mm)			with L <sub>ca</sub> = (mm)		
Version							12 x 2	12 x 5	12 x 10	35	100	variable <sup>3)</sup>	60	125
Without drive	OA01 			LSS	-	050			01	02	05	40	41	
				LPG	-	050			-	302	305	-	341	
Without attachment	OF01 	01	03	04	LSS	∅8	03	01	02	01	02	05	40	41
Flange/coupling	MF01 				LPG	∅8	31	32	33	-	302	305	-	341
Belt side drive	RV01 	RV02 			LCO	∅8	21	22	23	-			141	
	RV03 	RV04 			LCF	∅8	03	01	02	-			241	

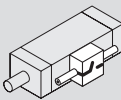
1) Length calculation of the linear motion system → "Project planning/calculation" chapter.  
 2) Centering holes for simple combination with other linear motion systems and connection elements (see dimension drawings).  
 Option 03: with centering holes and fastening threads in the ground area of the frame  
 Option 04: with centering holes and long hole in the ground area of the frame; selectable starting from length L ≥ 300 mm up to length L<sub>max</sub>  
 3) Lubrication → Chapter "Lubrication".  
 4) Attachment kit also available without motor. When ordering, enter the motor type "00"! Attachment kits according to customer specifications → Chapter "Attachment Kits for Motors according to Customer Specifications"  
 5) Recommended motor, motor data and type designations → Chapter "Motors"  
 6) More information → Chapter "Switching system"  
 7) Assembly contains 1 x sensor, 1 x switch mounting plate including set screws and square nuts as well as 3 x cable holders including set screws  
 8) Measurement report: 01 = standard report; 02 = Measurement of frictional torque; 03 = Lead deviation (see also "Documentation" chapter)

Motor attachment		Motor <sup>5)</sup>						Cover		Switching system <sup>6)</sup>		Automation package			Docu- menta- tion <sup>8)</sup>			
																		
i =	Attachment kit <sup>4)</sup>	Motor code	2 cables		1 cable		Motor connector position	Cover strip				Controller	Cable	Software				
			without brake	with brake	without brake	with brake		without	with									
OA01	-	00	-	-	00	-	-	-	-	Without		"Automation package" chapter			01			
OF01	-	00	-	-	00	-	-	-	-	- Switch - Cable duct - Socket-connector						00		
MF01	-	01	MS2N03-B0BYN	-	-	203	204	000	01	02	Magnetic sensor							
		05	MSM031C-0300	138	139	-	-				REED, changeover (NC: C+NC, NO: C+NO)					21		
RV01 - RV04	1	11	MS2N03-B0BYN	-	-	203	204	090	01	02	Hall, PNP normally closed (NC)					22		
		13	MSM031C-0300	138	139	-	-				Hall, PNP normally open (NO)					23		
	1.5	21	MS2N03-B0BYN	-	-	203	204	180			Cable duct					25		
		23	MSM031C-0300	138	139	-	-				270					Socket-connector	17	
											Magnetic sensor with connector <sup>7)</sup>							
											REED, changeover (NC: C+NC, NO: C+NO)					58		
											Hall, PNP normally closed (NC)	59						

Flange	Motor connector position			
	0°	90°	180°	270°
MF01	000	090 ★	180	270

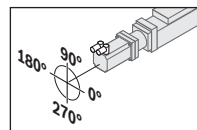

Example:  
Flange MF01  
Motor connector position 90°

Belt side drive	Motor connector position			
	0°	90°	180°	270°
RV01	000	-	180	270 ★
RV02	000	090 ★	180	-
RV03	000 ★	090	-	270
RV04	-	090	180 ★	270

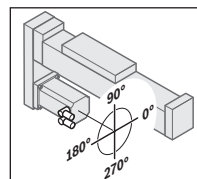

Example:  
Belt side drive RV01  
Motor connector position 180°



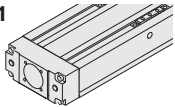
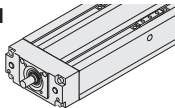
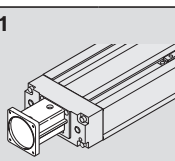
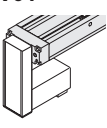
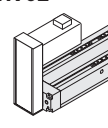
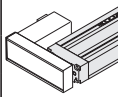
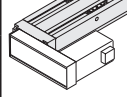

★ Standard delivery

Explanation of the order parameters and ordering example ⇒ Chapter "Ordering example".

**CKK-110**

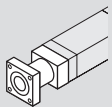
Short product name, length <sup>1)</sup> CKK-110-NN-1, ... mm		Guideway		Lubrication <sup>3)</sup>	Drive			Carriage						
		Standard	Centering holes <sup>2)</sup>		Screw journal (mm)	BASA d <sub>0</sub> x P (mm)			Connection plate without L <sub>ca</sub> = (mm)			with L <sub>ca</sub> = (mm)		
Version							16 x 5	16 x 10	16 x 16	39	124	variable <sup>3)</sup>	60	155
Without drive	OA01 	01	03	04	LSS	-	050			01	02	05	40	41
					LPG					-	302	305	-	341
Without attachment	OF01 	01	03	04	LSS	Ø11 with keyway (OF01)	11	12	13	01	02	05	40	41
Flange/ coupling	MF01 				LSS	Ø11	01	02	03	01	02	05	40	41
					LPG	Ø11	31	32	33	-	302	305	-	341
Belt side drive	RV01 				RV02 	LCF	Ø11	01	02	03	-			141
	RV03 				RV04 	LCO	Ø11	01	02	03	-			241

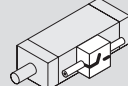
1) Length calculation of the linear motion system ⇒ "Project planning/calculation" chapter.  
 2) Centering holes for simple combination with other linear motion systems and connection elements (⇒ Dimension drawings).  
 Option 03: with centering holes and fastening threads in the ground area of the frame  
 Option 04: with centering holes and long hole in the ground area of the frame; selectable starting from length L ≥ 300 mm up to length L<sub>max</sub>  
 3) Lubrication ⇒ Chapter "Lubrication".  
 4) Attachment kit also available without motor. When ordering, enter the motor type "00"! Attachment kits according to customer specifications ⇒ Chapter "Attachment Kits for Motors according to Customer Specifications"  
 5) Recommended motor, motor data and type designations ⇒ Chapter "Motors"  
 6) Only possible with version Carriage with connection plate L<sub>ca</sub> = 155 mm; Switch mounting only possible with magnetic sensor with connector. (It may be necessary to move the mounting brackets for Resist cover)  
 7) More information ⇒ Chapter "Switching system"  
 8) Assembly contains 1 x sensor, 1 x switch mounting plate including set screws and square nuts as well as 3 x cable holders including set screws  
 9) Measurement report: 01 = Standard report; 02 = Measurement of frictional torque; 03 = Lead deviation (⇒ Chapter "Documentation")

Motor attachment		Motor <sup>5)</sup>						Cover		Switching system <sup>7)</sup>		Automation package			Documentation <sup>9)</sup>
															
i =	Attachment kit <sup>4)</sup>	Motor code	2 cables		1 cable		Motor connector position	without	with	Resist <sup>6)</sup>	Controller	Cable	Software		
			without brake	with brake	without brake	with brake									
OA01	-	00	-	-	00	-	-				Without				
OF01	-	00	-	-	00	-	-				- Switch - Cable duct - Socket-connector			00	
MF01	-	01	MS2N03-B0BYN	-	-	203	204	000	01	02	12	Magnetic sensor			
		07	MS2N03-D0BYN	-	-	207	208					REED, changeover (NC: C+NC, NO: C+NO)	21		
		03	MS2N04-C0BTN	-	-	215	216					Hall, PNP normally closed (NC)	22		
			MS2N04-D0BQN	-	-	219	220					Hall, PNP normally open (NO)	23		
		05	MSM031C-0300	138	139	-	-					Cable duct	25		
		06	MSM041B-0300	140	141	-	-					Socket-connector	17		
RV01 - RV04	1	11	MS2N03-B0BYN	-	-	203	204	090				Magnetic sensor with connector <sup>8)</sup>			
		13	MS2N04-C0BTN	-	-	215	216					REED, changeover (NC: C+NC, NO: C+NO)	58		
		15	MSM031C-0300	138	139	-	-					Hall, PNP normally closed (NC)	59		
		17	MSM041B-0300	140	141	-	-								
	1.5	21	MS2N03-B0BYN	-	-	203	204	270							
		23	MS2N04-B0BTN	-	-	211	212								
		25	MSM031C-0300	138	139	-	-								
	27	MSM041B-0300	140	141	-	-									

Flange	Motor connector position			
	0°	90°	180°	270°
MF01	000	090 ★	180	270

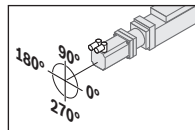

Example:  
Flange MF01  
Motor connector position 90°

Belt side drive	Motor connector position			
	0°	90°	180°	270°
RV01	000	-	180	270 ★
RV02	000	090 ★	180	-
RV03	000 ★	090	-	270
RV04	-	090	180 ★	270

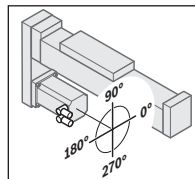

Example:  
Belt side drive RV01  
Motor connector position 180°

★ Standard delivery

Explanation of the order parameters and ordering example ⇒ Chapter "Ordering example".

**CKK-145**

Short product name, length <sup>1)</sup> CKK-145-NN-1, ... mm		Guideway		Lubrication <sup>3)</sup>	Drive				Carriage						
		Standard	Centering holes <sup>2)</sup>		Screw journal (mm)	BASA d <sub>0</sub> x P (mm)				Connection plate without L <sub>ca</sub> = (mm)			with L <sub>ca</sub> = (mm)		
Version						20 x 5	20 x 20	25 x 10	20 x 40	49	149	variable <sup>1)</sup>	80	190	
Without drive	OA01	01	03	04	LSS	-				01	02	05	40	41	
					LPG	050				-	302	305	-	341	
Without attachment	OF01	01	03	04	LSS	Ø14 with keyway (OF01)	14	15	16	-	01	02	05	40	41
									-	17	06	07	10	08	09
Flange/coupling	MF01	01	03	04	LSS	Ø14	21	22	23	-	01	02	05	40	41
									-	24	06	07	10	08	09
Belt side drive	RV01	01	03	04	LPG	Ø14	31	32	33	-	-	302	305	-	341
									-	34	-	307	310	-	309
	RV02	LSS	Ø14	21	22	23	-	-					141		
						-	24	-					109		
	RV03	LSS	Ø14	21	22	23	-	-					241		
						-	24	-					209		
RV04	LCO	Ø14	21	22	23	-	-					241			
					-	24	-					209			

1) Length calculation of the linear motion system ⇒ "Project planning/calculation" chapter.  
 2) Centering holes for simple combination with other linear motion systems and connection elements (⇒ Dimension drawings).  
 Option 03: with centering holes and fastening threads in the ground area of the frame  
 Option 04: with centering holes and long hole in the ground area of the frame; selectable starting from length L ≥ 300 mm up to length L<sub>max</sub>  
 3) Lubrication ⇒ Chapter "Lubrication".  
 4) Attachment kit also available without motor. When ordering, enter the motor type "00"! Attachment kits according to customer specifications ⇒ Chapter "Attachment Kits for Motors according to Customer Specifications"  
 5) Recommended motor, motor data and type designations ⇒ Chapter "Motors"  
 6) Only possible with version Carriage with connection plate L<sub>ca</sub> = 190 mm; Switch mounting only possible with magnetic sensor with connector. (It may be necessary to move the mounting brackets for Resist cover)  
 7) More information ⇒ Chapter "Switching system"  
 8) Assembly contains 1 x sensor, 1 x switch mounting plate including set screws and square nuts as well as 3 x cable holders including set screws  
 9) Measurement report: 01 = Standard report; 02 = Measurement of frictional torque; 03 = Lead deviation (⇒ Chapter "Documentation")



Motor attachment	Attachment kit <sup>(4)</sup>		Motor code				Motor connector position	Cover		Resist <sup>(6)</sup>	Switching system <sup>(7)</sup>		Automation package			Documentation <sup>(9)</sup>					
	i =		2 cables		1 cable			without	with		without	with	Controller	Cable	Software						
			without brake	with brake	without brake	with brake					Without		"Automation package" chapter			01					
OA01	-	00	-	-	00	-	-	-	-	-	- Switch - Cable duct - Socket-connector						00				
OF01	-	00	-	-	00	-	-	-	-	-	Magnetic sensor										
MF01	-	30	MS2N04-C0BTN	-	-	215	216	000	01	02	12	REED, changeover (NC: C+NC, NO: C+NO)	21	"Automation package" chapter			02				
		32	MS2N04-D0BQN	-	-	219	220					Hall, PNP normally closed (NC)	22								
		33	MS2N05-B0BTN	-	-	223	224					Hall, PNP normally open (NO)	23								
			MS2N05-C0BTN	-	-	227	228					Cable duct	25								
			MS2N05-D0BRN	-	-	231	232					Socket-connector	17								
RV01 - RV04	1	11	MS2N04-C0BTN	-	-	215	216	090				Magnetic sensor with connector <sup>(8)</sup>									03
		MS2N04-D0BQN	-	-	219	220	REED, changeover (NC: C+NC, NO: C+NO)					58									
		35	MS2N05-D0BRN	-	-	231	232					Hall, PNP normally closed (NC)	59								
		17	MSM041B-0300	140	141	-	-														
	1.5	21	MS2N04-B0BTN	-	-	211	212	270													
		MS2N04-C0BTN	-	-	215	216															
		MS2N04-D0BQN	-	-	219	220															
		27	MSM041B-0300	140	141	-	-														
2	36	MS2N05-B0BTN	-	-	223	224															

Flange	Motor connector position			
	0°	90°	180°	270°
MF01	000	090 ★	180	270

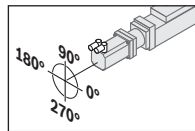

Example:  
Flange MF01  
Motor connector position 90°

Belt side drive	Motor connector position			
	0°	90°	180°	270°
RV01	000	-	180	270 ★
RV02	000	090 ★	180	-
RV03	000 ★	090	-	270
RV04	-	090	180 ★	270

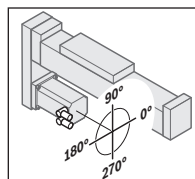

Example:  
Belt side drive RV01  
Motor connector position 180°

★ Standard delivery

Explanation of the order parameters and ordering example ➡ Chapter "Ordering example".

**CKK-200**

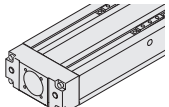
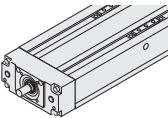
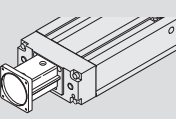
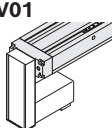
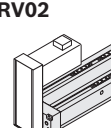
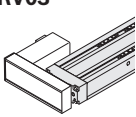
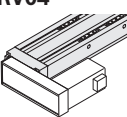
Short product name, length <sup>1)</sup> CKK-200-NN-1, ... mm		Guideway		Lubrication <sup>3)</sup>	Drive				Carriage							
		Standard	Centering holes <sup>2)</sup>		Screw journal (mm)	BASA d <sub>0</sub> x P (mm)				SPU Number	Connection plate without			with		
32 x 5	32 x 10			32 x 20		32 x 32	L <sub>ca</sub> = (mm)				L <sub>ca</sub> = (mm)					
Version									79.5	254.5	variable <sup>1)</sup>	190	305			
Without drive	OA01 	01	03	04	LSS	-				-	01	11	18	40	41	
					LPG	050				-	-	311	318	-	341	
Without attachment	OF01 	01	03	04	LSS	Ø16 with keyway	11	12	13	14	0	01	11	18	40	41
							1	2	3	0	02	12	-	-	26	
Flange/coupling	MF01 	01	03	04	LSS	Ø16	01	02	03	04	2	03	13	-	-	27
							3	0	04	14	-	-	28			
Belt side drive	RV01 	01	03	04	LPG	Ø16	31	32	33	34	0	-	311	318	-	341
											1	-	312	-	-	326
											2	-	313	-	-	327
	RV02 	01	03	04	LPG	Ø16	31	32	33	34	3	-	314	-	-	328
											0	-	-	-	-	141
											1	-	-	-	-	126
	RV03 	01	03	04	LCO	Ø16	01	02	03	04	2	-	-	-	-	127
											3	-	-	-	-	128
											0	-	-	-	-	241
	RV04 	01	03	04	LCO	Ø16	01	02	03	04	1	-	-	-	-	226
											2	-	-	-	-	227
											3	-	-	-	-	228

1) Length calculation of the linear motion system → "Project planning/calculation" chapter.  
 2) Centering holes for simple combination with other linear motion systems and connection elements (→ Dimension drawings).  
 Option 03: with centering holes and fastening threads in the ground area of the frame; selectable up to length L ≤ 2000 mm  
 Option 04: with centering holes and long hole in the ground area of the frame; selectable starting from length L ≥ 300 mm up to length L<sub>max</sub>  
 3) Lubrication → Chapter "Lubrication".  
 4) Attachment kit also available without motor. When ordering, enter the motor type "00"! Attachment kits according to customer specifications → Chapter "Attachment Kits for Motors according to Customer Specifications"  
 5) Recommended motor, motor data and type designations → Chapter "Motors"  
 6) Only possible with version Carriage with connection plate L<sub>ca</sub> = 305 mm; Switch mounting only possible with magnetic sensor with connector. (It may be necessary to move the mounting brackets for Resist cover)  
 7) More information → Chapter "Switching system"  
 8) Assembly contains 1 x sensor, 1 x switch mounting plate including set screws and square nuts as well as 3 x cable holders including set screws  
 9) Switch configuration with magnetic sensor and mechanical/proximity switch together on one side is not possible. Assembly contains 1 x sensor, 1 x switch mounting plate including mounting material  
 10) Switching cam can be attached only in conjunction with connection plate  
 11) Measurement report: 01 = Standard report; 02 = Measurement of frictional torque; 03 = Lead deviation (→ Chapter "Documentation")

Motor attachment	Motor <sup>5)</sup>				Cover	Switching system <sup>7)</sup>	Automation package			Documentation <sup>11)</sup>	
	Attachment kit <sup>4)</sup>	Motor code		Motor connector position			Controller	Cable	Software		
i =		without brake	with brake	without brake	with brake	without	with	Resist <sup>6)</sup>			
OA01	-	00	-	00	-	Without			"Automation package" chapter	01	
OF01	-	00	-	00	-	- Switch		00			
	-	00	-	00	-	- Cable duct					
	-	00	-	00	-	- Socket-connector					
MF01	-	03	MS2N06-D0BRN	-	-	243	244	Magnetic sensor		02	
	-	03	MS2N06-E0BRN	-	-	251	252	REED, changeover (NC: C+NC, NO: C+NO)			
	-	03	MS2N06-E0BRN	-	-	251	252	Hall, PNP normally closed (NC)			
	-	03	MS2N06-E0BRN	-	-	251	252	Hall, PNP normally open (NO)			
	-	04	MS2N07-C0BQN	-	-	259	260	Cable duct			
	-	04	MS2N07-C0BQN	-	-	259	260	Socket-connector			
RV01 - RV04	1	27	MS2N06-B1BNN	-	-	235	236	Magnetic sensor with connector <sup>8)</sup>		03	
	1	27	MS2N06-D1BNN	-	-	247	248	REED, changeover (NC: C+NC, NO: C+NO)			
	1	27	MS2N06-D1BNN	-	-	247	248	Hall, PNP normally closed (NC)			
	1	27	MS2N06-D1BNN	-	-	247	248	Proximity/mechanical switches <sup>9)</sup>			
	1	27	MS2N06-D1BNN	-	-	247	248	Mechanical			
	1	27	MS2N06-D1BNN	-	-	247	248	Proximity - PNP NC contact			
	1	27	MS2N06-D1BNN	-	-	247	248	Proximity - PNP NO contact			
	1	27	MS2N06-D1BNN	-	-	247	248	Cable duct			
	2	28	MS2N06-C0BTN	-	-	239	240	Switching cam <sup>10)</sup>			
	2	28	MS2N06-C0BTN	-	-	239	240	1 16			
	2	28	MS2N06-C0BTN	-	-	239	240	2 26			
	2	28	MS2N06-C0BTN	-	-	239	240	Socket-connector			
	2	28	MS2N06-C0BTN	-	-	239	240	17			

Flange	Motor connector position			
	0°	90°	180°	270°
MF01	000	090 ★	180	270

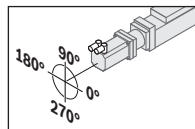

Example:  
Flange MF01  
Motor connector position 90°

Belt side drive	Motor connector position			
	0°	90°	180°	270°
RV01	000	-	180	270 ★
RV02	000	090 ★	180	-
RV03	000 ★	090	-	270
RV04	-	090	180 ★	270

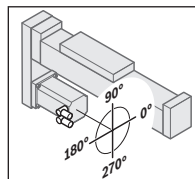

Example:  
Belt side drive RV01  
Motor connector position 180°

★ Standard delivery

Explanation of the order parameters and ordering example ⇒ Chapter "Ordering example".

Dimension drawings

**Frame CKK-070/-090/-110/-145**

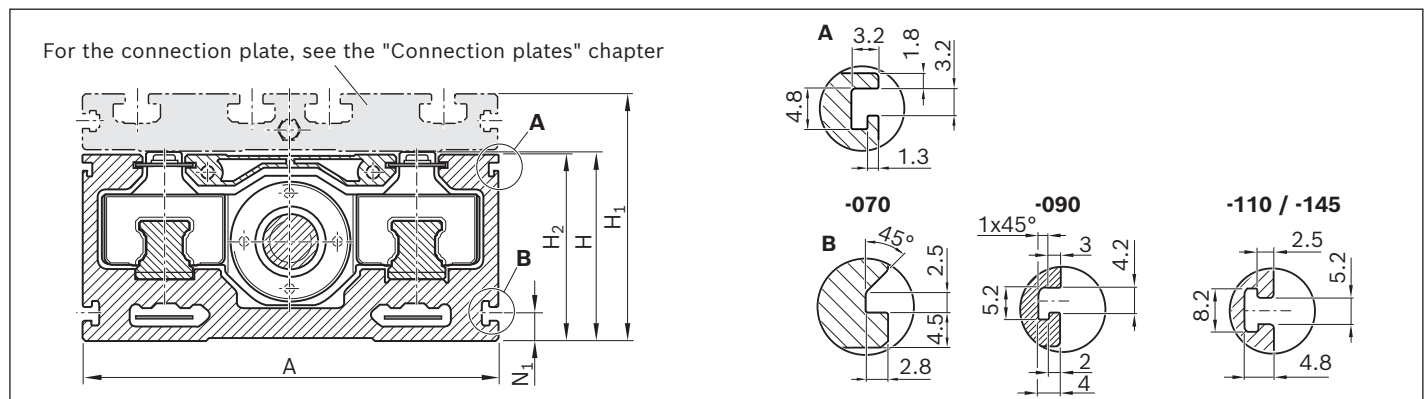
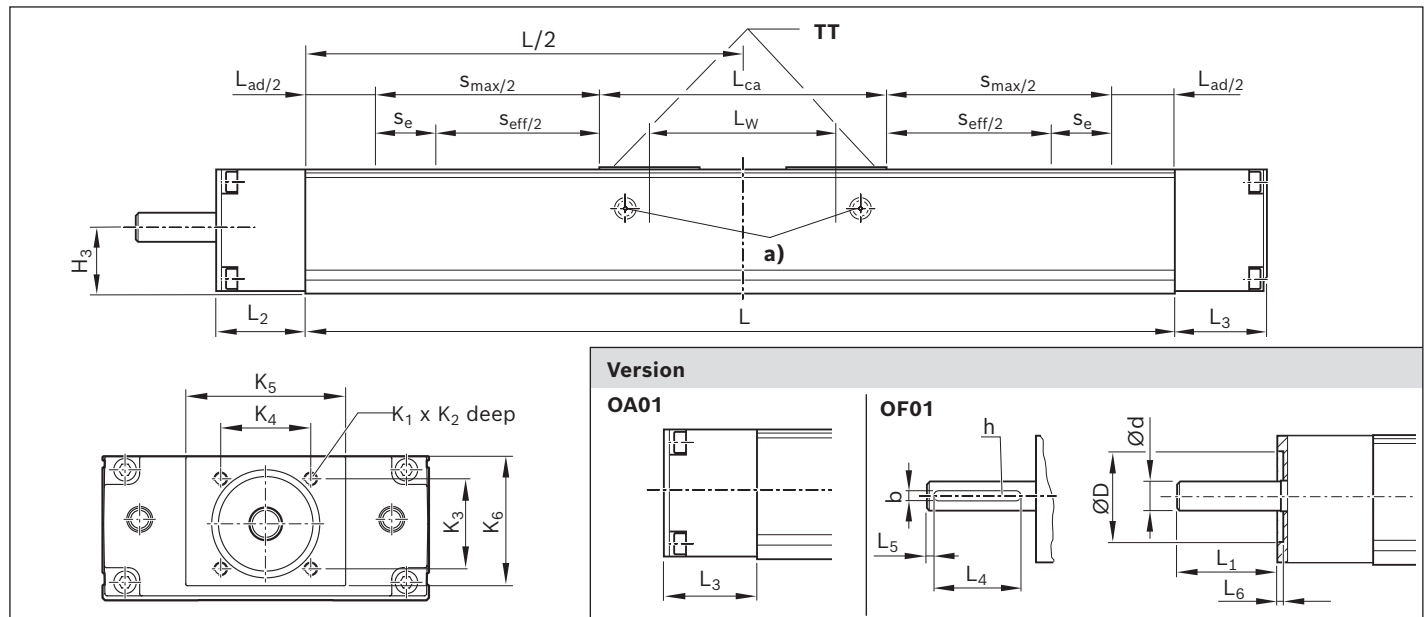

CKK	Dimensions (mm)												
	A	B	b <sup>P9</sup>	H	H <sub>1</sub>	H <sub>2</sub>	H <sub>3</sub>	h	ØD <sup>H7</sup>	ØD <sub>1</sub> <sup>-0.01</sup>	ØD <sub>2</sub>	Ød <sub>h7</sub>	
<b>-070</b>	70	-	-	32	44.5	31.3	16.0	-	28	-	-	6	
<b>-090</b>	90	-	-	40	56.0	39.0	21.0	-	28	-	-	8	
<b>-110</b>	110	-	4	50	66.0	49.0	25.5	2.5	40	-	-	11	
<b>-145</b>	145	-	5	65	85.0	64.0	34.0	3.0	48	-	-	14	
<b>-200</b>	200	150	5	100	127.0	98.5	56.0	3.0	-	68	32	16	

a) Lube port on both sides (grease lubrication). ⇒ Chapter "Lubrication".

Straightness and flatness tolerance in accordance with DIN EN 12020-2.

Note: all dimensions in mm. Drawings not schematically to scale.

Exact contours and dimensions can be found in the CAD model.

CAD configurator available on the Internet at [www.boschrexroth.com](http://www.boschrexroth.com) "Product configurators".

See following pages for dimension drawings for frames, carriages and motor attachment.

Length calculation of the linear motion system ⇒ Chapters "Technical data" and "Project planning/calculation".

**Frame CKK-200**

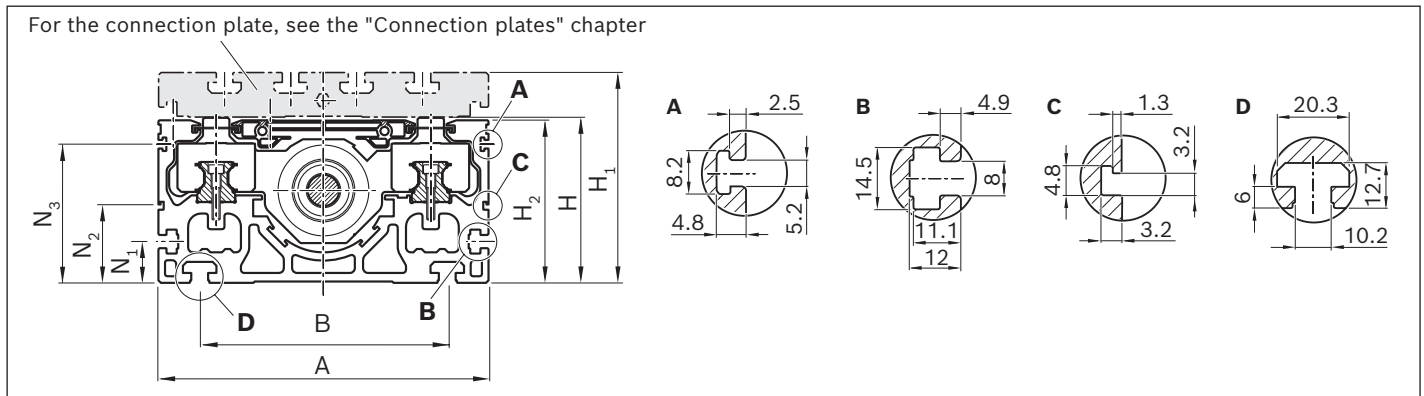
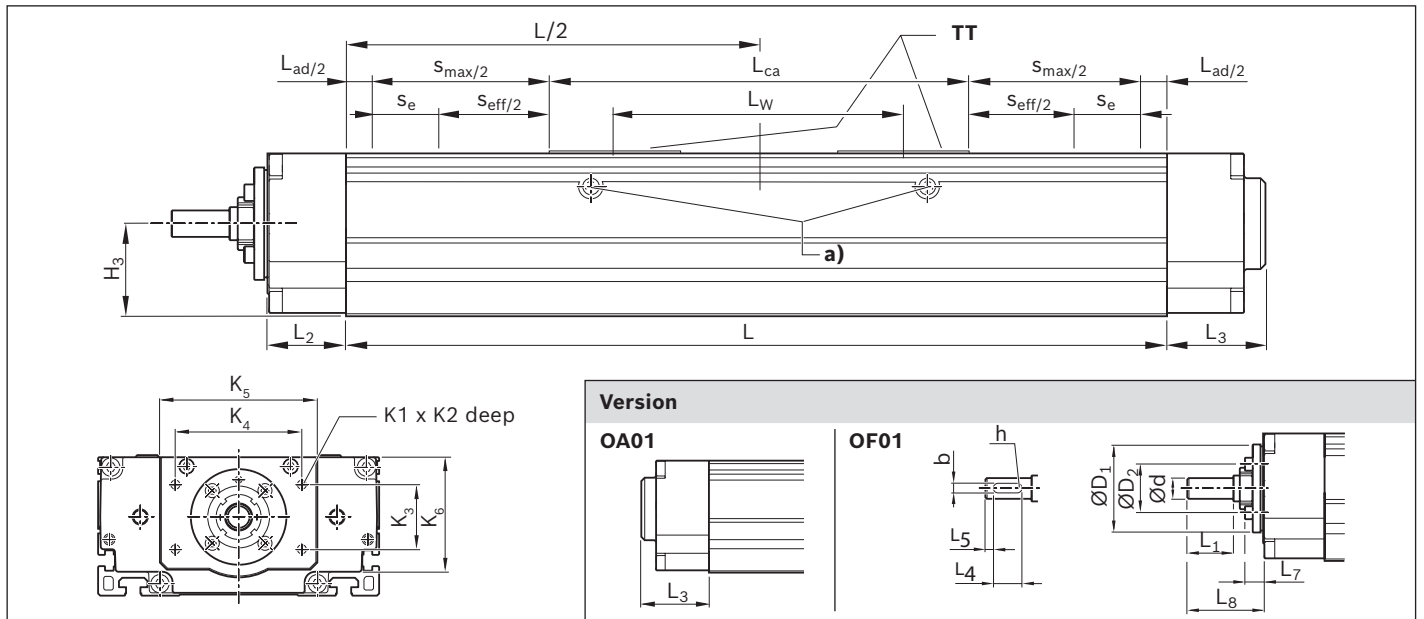

K <sub>1</sub>	K <sub>2</sub>	K <sub>3</sub>	K <sub>4</sub>	K <sub>5</sub>	K <sub>6</sub>	L <sub>1</sub>	L <sub>2</sub>	L <sub>3</sub>	L <sub>4</sub>	L <sub>5</sub>	L <sub>6</sub>	L <sub>7</sub>	L <sub>8</sub>	N <sub>1</sub>	N <sub>2</sub>	N <sub>3</sub>
M4	8	23	33	44	31.3	18	22.0	29.0	-	-	2.5	-	-	-	-	-
M4	9	29	41	50	39.0	20	32.0	33.5	-	-	2.5	-	-	7.6	-	-
M6	12	28	40	56	49.0	32	36.0	38.0	20	3.0	2.5	-	-	9.5	-	-
M6	12	40	40	71	57.5	44	43.5	45.0	25	10.0	2.5	-	-	9.5	-	-
M8	12	46	90	112	85.5	35	47.5	59.5	28	3.5	-	14	58	25.0	47.5	84

- A** For switch mounting arrangements
  - B** For mounting with clamping fixtures
  - C** For cable duct
  - D** For fastening with sliding blocks
- TT = Carriage

**Frame CKK-070/-090/-110/-145**

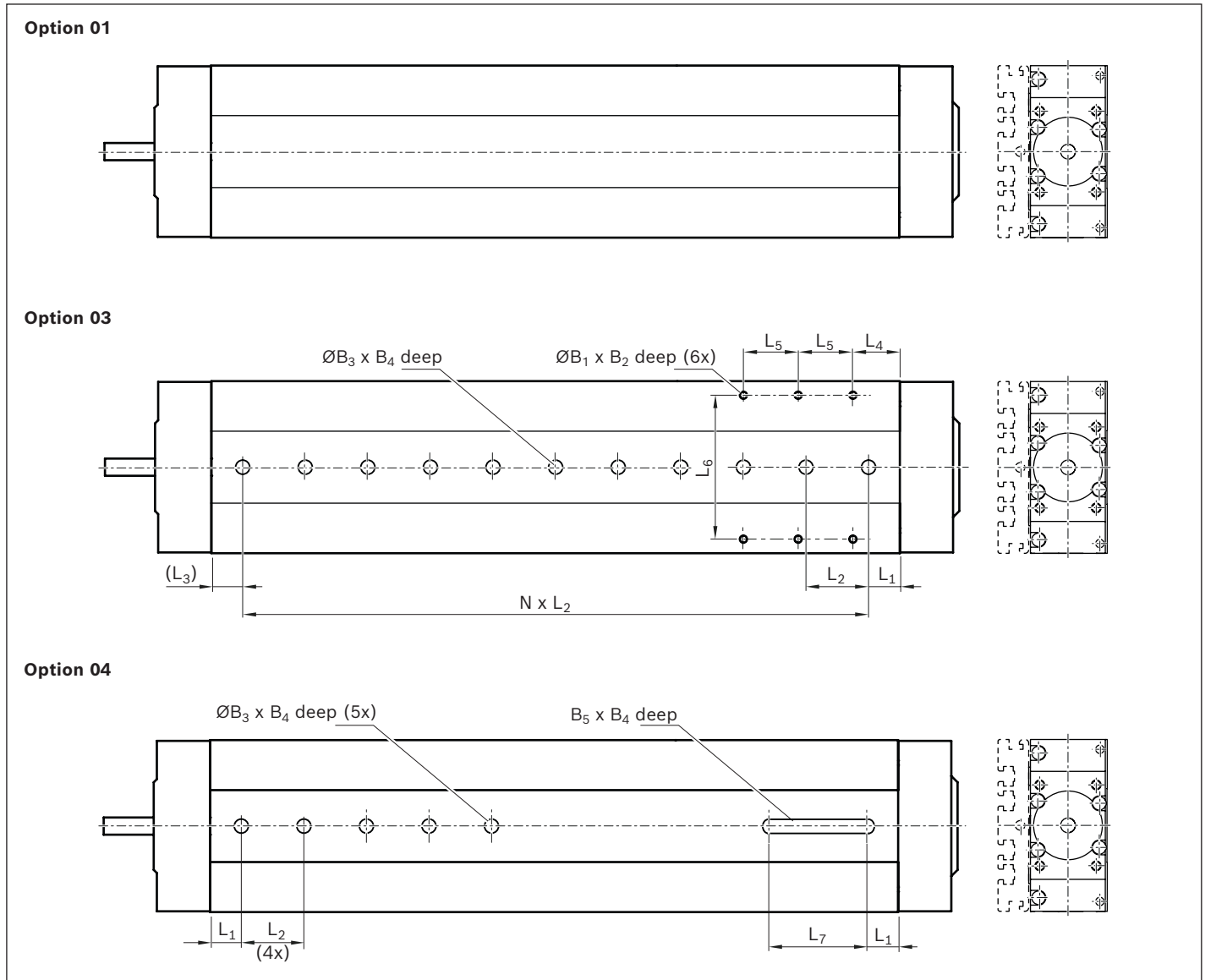

CKK	Option	Dimensions (mm)						L <sub>1</sub>	L <sub>2</sub> <sup>±0.01</sup>	L <sub>3</sub> (min)	L <sub>4</sub>	L <sub>5</sub>	L <sub>6</sub>	L <sub>7</sub>
		B <sub>1</sub>	B <sub>2</sub>	ØB <sub>3</sub> <sup>H7</sup>	B <sub>4</sub>	B <sub>5</sub> <sup>H8</sup>								
-070	03	M3	6	7	1.6	-	20	40	10	15	25	59	-	
	04	-	-	-	-	7			-	-	-	-	-	60
-090	03	M4	7.5	9	2.1	-			-	10	30	35	76	-
	04	-	-	-	-	9			-	-	-	-	-	60
-110	03	M5	9	9	2.1	-			-	10	30	35	92	-
	04	-	-	-	-	9			-	-	-	-	-	60
-145	03	M6	13	12	2.1	-	-	10	30	35	124	-		
	04	-	-	-	-	12	-	-	-	-	-	60		
-200	03	M8	12	16	3.1	-	-	10	35	40	119	-		
	04	-	-	-	-	16	-	-	-	-	-	60		

**Frame CKK-200**

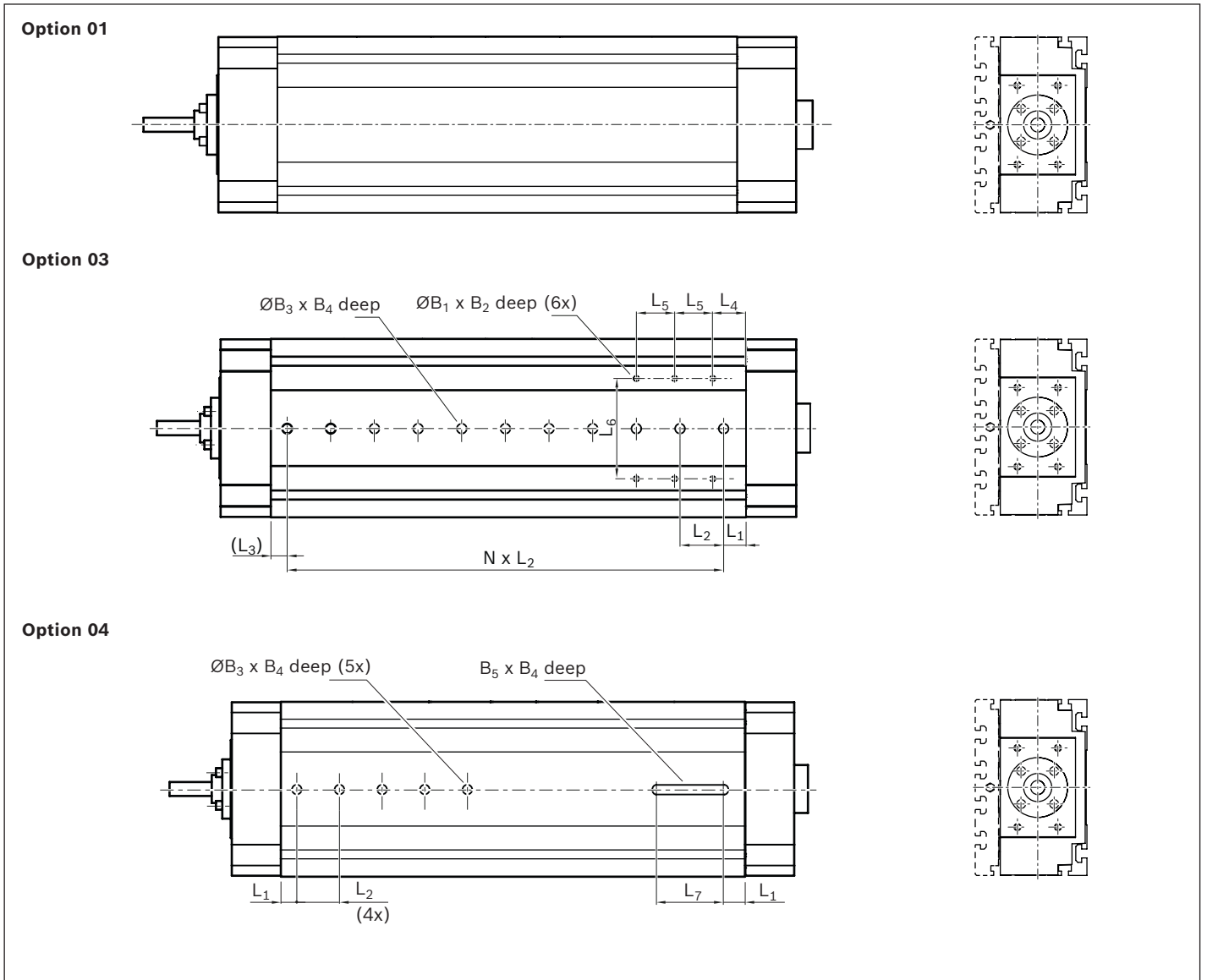

Views from below (ground area)

Option 01 / standard

Option 03 / with centring holes

Option 04 / with centring holes and long hole

**Carriages CKK-070/-090/-110/-145/-200**

**Carriage without connection plate**

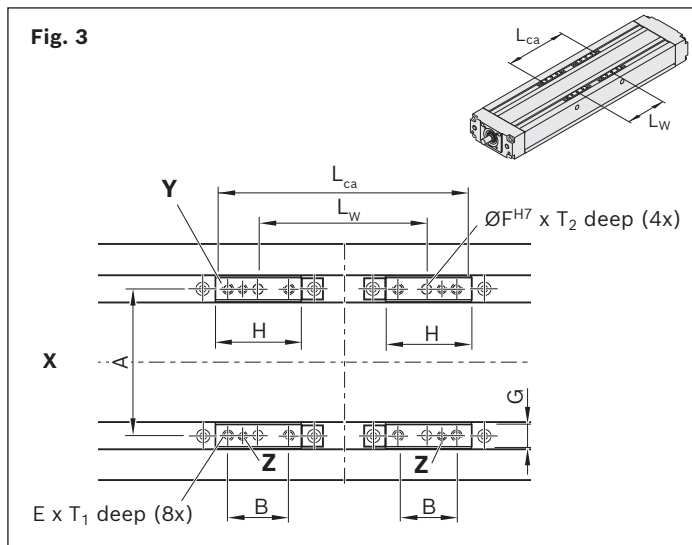
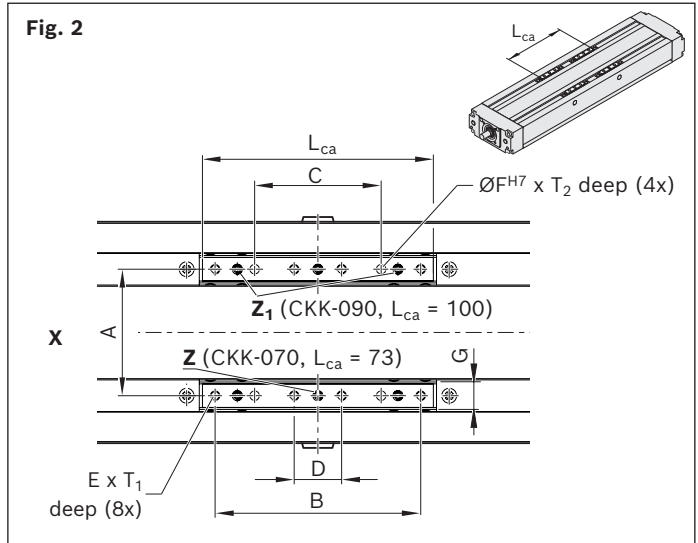
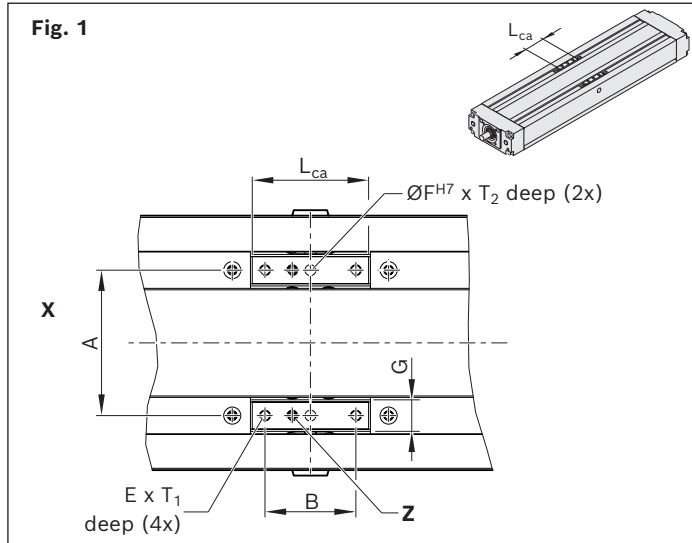

**X** Drive side  
**Y** Drive carriage  
**Z/Z1** Lubrication point for grease; sealed with set screw.  
 Supplementary information for lubrication → Chapter "Lubrication".

**Carriage with connection plate<sup>1)</sup>**

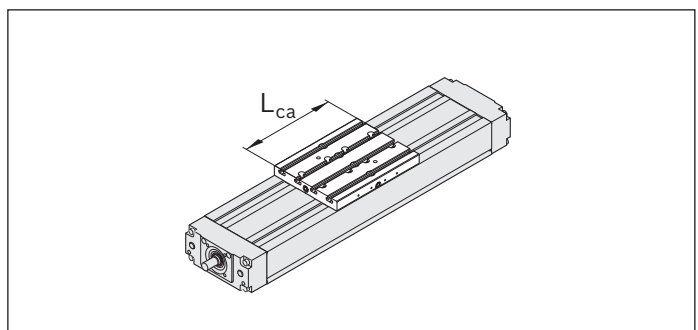
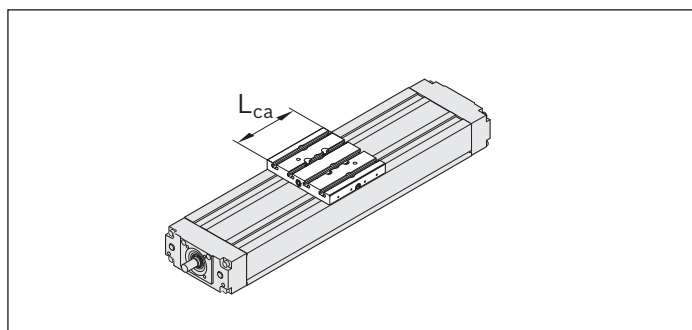

<sup>1)</sup> Dimension drawings → Chapter "Connection plates"



CKK	Figure	Dimensions (mm)												
		L <sub>ca</sub>	L <sub>w</sub>	A	B	C	D	E	ØF <sup>H7</sup>	G	H	T <sub>1</sub>	T <sub>2</sub>	
-070	1	32	-	40	25	-	-	M3	3	7.5	-	5	5	
	2	73			65	40	15							
-090	1	35	-	54	27	-	-	M4	4	8.0	35	7	6	
	2	100			92	65	38							
	3	variable min. 101 max. 235			min. 66 max. 200	27	-							-
-110	1	39	-	66	30	-	-	M5	5	10.0	39	10	8	
	3	124												85
	3	variable min. 125 max. 289												min. 86 max. 250
-145	1	49	-	88	36	-	-	M6	6	12.0	49	12	10	
	3	149												100
	3	variable min. 150 max. 349												min. 101 max. 300
-200	1	79.5	-	130	60	-	-	M8	8	16.0	79.5	16	12	
	3	254.5												175
	3	variable min. 255.5 max. 429.5												min. 176 max. 350

**Motor attachment with flange and coupling**

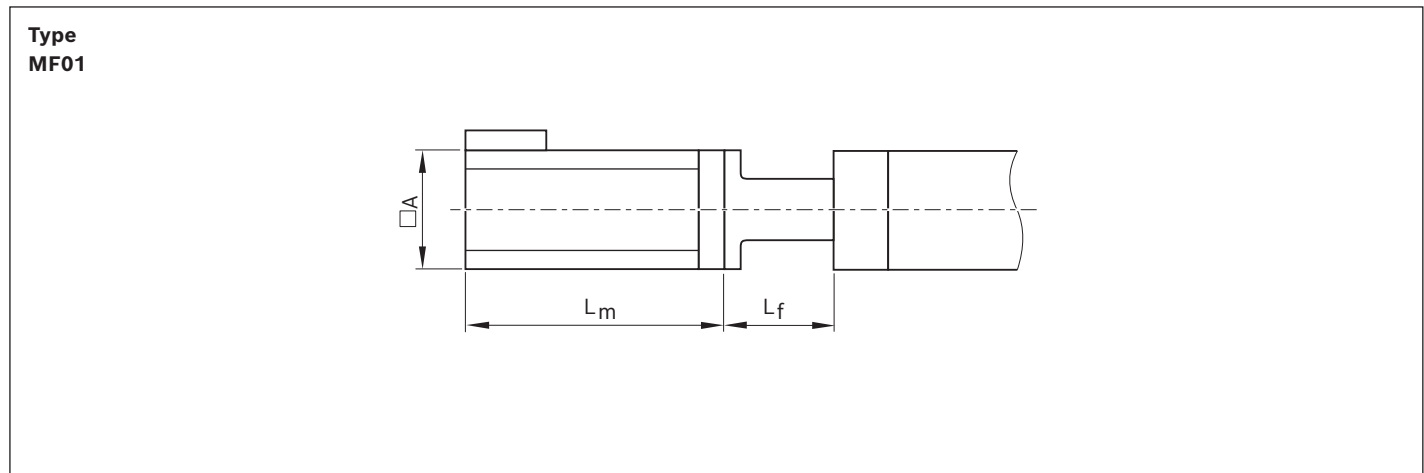

CKK	Motor code	Dimensions (mm)		
		L <sub>f</sub>	L <sub>m</sub>	□A
<b>-070</b>	MS2N03-B0BYN	50.0		
	MSM031B-0300			
	MSM019B-0300			
<b>-090</b>	MS2N03-B0BYN	70.0		
	MSM031C-0300	71.5		
<b>-110</b>	MS2N03-B0BYN	75.0		
	MS2N03-D0BYN			
	MS2N04-C0BTN	77.5		
	MS2N04-D0BQN			
	MSM031C-0300	72.0		
	MSM041B-0300	83.0		
<b>-145</b>	MS2N04-C0BTN	85.0		
	MS2N04-D0BQN	90.0		
	MSM041B-0300			
	MS2N05-B0BTN	95.0		
	MS2N05-C0BTN			
MS2N05-D0BRN				
<b>-200</b>	MS2N06-D0BRN	125.0		
	MS2N06-E0BRN			
	MS2N07-C0BQN	133.0		
	MS2N07-D0BRN			

⇒ Chapter "Motors"

**Motor attachment with belt side drive**

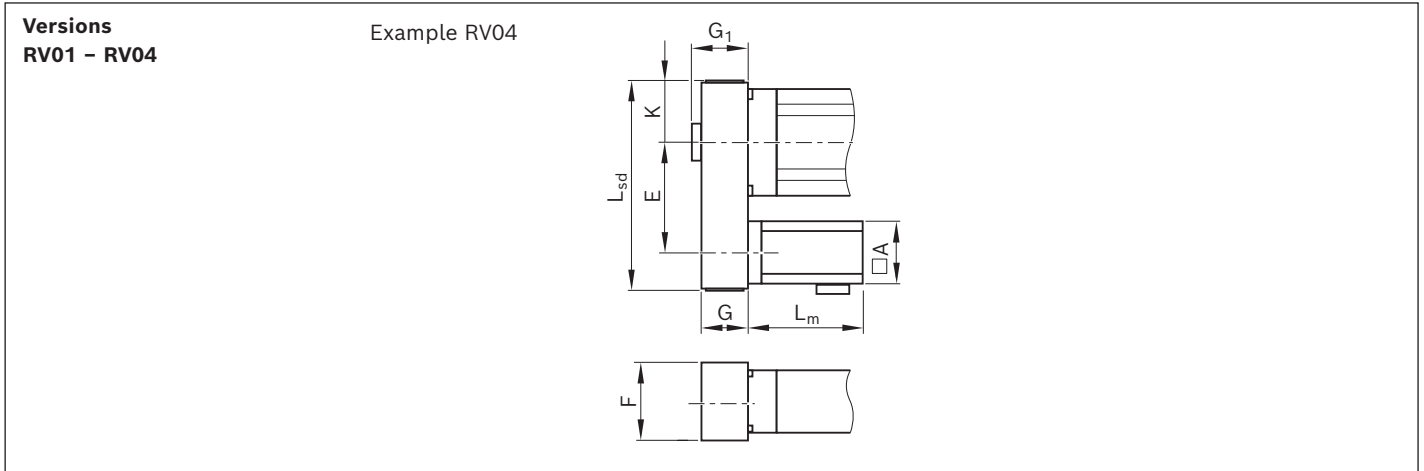

CKK	Motor code	Dimensions (mm)										L <sub>sd</sub>	L <sub>m</sub>	□A
		i=1	i=1.5	E i=2	F	G	G <sub>1</sub>	K	i=1	i=1.5	i=2			
<b>-070</b>	MS2N03-B0BYN	103.5	89.5	-	64.5	37.0	44.0	33.5	179	165	-			
	MSM031B-0300								182	168				
	MSM019B-0300	76.5	76.5	-	48.0	27.5	28.0	27.5	139					
<b>-090</b>	MS2N03-B0BYN	103.5	89.5	-	64.5	37.0	-	33.0	179	165	-			
	MSM031C-0300													
<b>-110</b>	MS2N03-B0BYN	103.5	115.0	-	64.5	37.0	-	33.0	179	191	-			
	MS2N04-B0BTN	-	139.5		88.0	51.0		43.5	-	250				
	MS2N04-C0BTN	145.0	-		88.0	51.0		43.5	250	-				
	MSM031C-0300	103.5	115.0		64.5	37.0		33.0	179	191				
	MSM041B-0300	145.0	139.5		88.0	51.0		43.5	250	250				
<b>-145</b>	MS2N04-B0BTN	-	162.0	-	88.0	51.0	-	43.5	-	267	-		Chapter "Motors"	
	MS2N04-C0BTN	157.5	162.0	-	88.0	51.0	-	43.5	267	267	-			
	MS2N04-D0BQN													
	MS2N05-B0BTN	165.0	-	162	116.0	66.0	-	56.0	297	-	297			
	MS2N05-D0BRN													
	MSM041B-0300	157.5	162.0	-	88.0	51.0	-	43.5	267	267	-			
<b>-200</b>	MS2N06-B1BNN	267.5	-	-	116.0	66.0	-	59.0	403	-	-			
	MS2N06-D1BNN													
	MS2N06-C0BTN	-	-	265	116.0	66.0	-	59.0	-	-	403			

# Compact modules with toothed belt drive (CKR)

## Product overview

### Features

- ▶ Five fine-tuned sizes based on a compact precision aluminum profile with two integrated preloaded ball rail systems
- ▶ Four different lube versions
- ▶ Ready-to-install compact modules in any length up to  $L_{max}$ .
- ▶ Realization of greater lengths of up to 10,000 mm
- ▶ Preloaded toothed belt
- ▶ Aluminum carriages available in different lengths
- ▶ Intelligent toothed belt guide protects inner components
- ▶ Low-cost maintenance
- ▶ Repeatability of up to  $\pm 0.05$  mm

### Further highlights

- ▶ Flexible thanks to selectable options
- ▶ Centering holes for simple combination with other linear motion systems and connection elements
- ▶ Extensive accessories for connection and clamping units
- ▶ Nameplate with parameters for easy commissioning

### Attachments

- ▶ Planetary gear with various gear ratios
- ▶ Maintenance-free servo motors with selectable brake and attached feedback
- ▶ Switches (magnetic sensors), switch activation without additional switching cam
- ▶ Socket and connector
- ▶ Cable duct made of aluminum for sensors

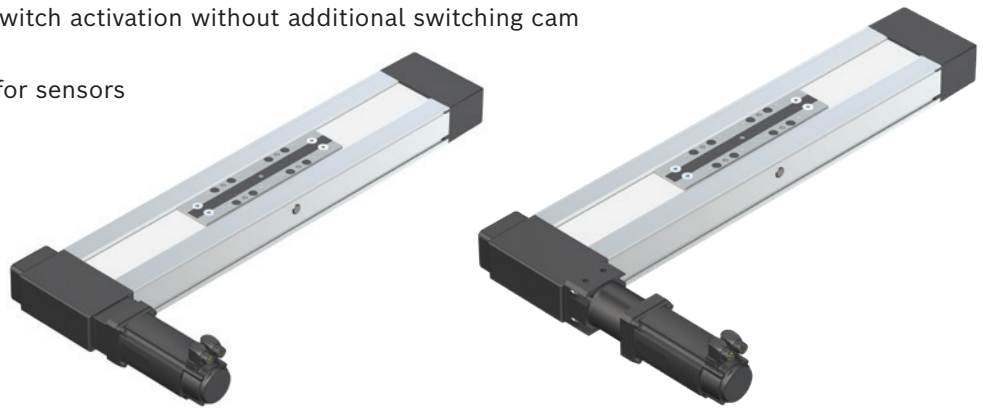

### Design/options for guideway (frame), carriages, connection plates

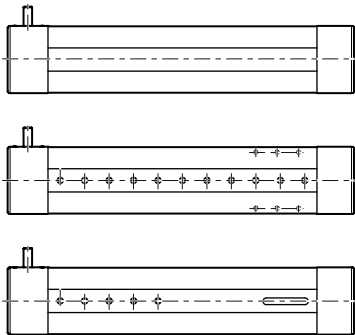

Guideway (frame)

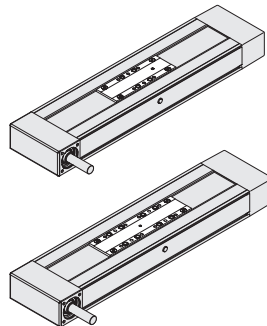

Carriages

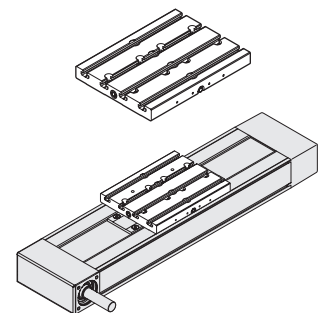

Connection plates

Structural design

**Structural design CKR**

- 1 Drive end enclosure
- 2 Frame
- 3 Toothed belt drive
- 4 Carriage
- 5 Idler end enclosure

**Attachments:**

- 6 Magnetic sensor
- 7 Cable duct
- 8 Socket/connector
- 9 Connection plate
- 10 Flange
- 11 Planetary gear
- 12 Motor

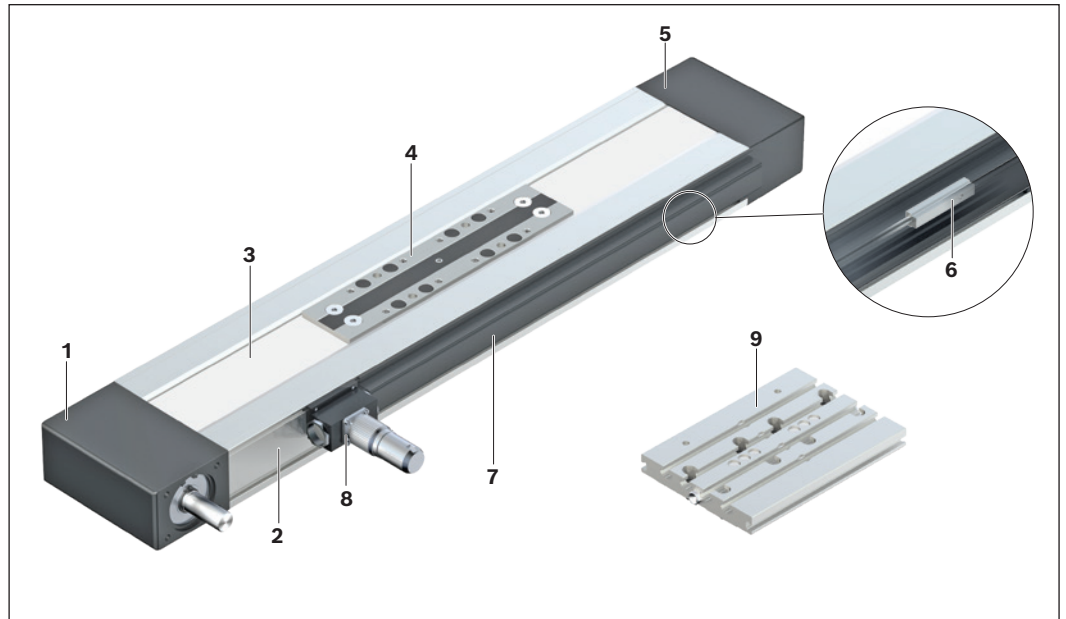

**Motor attachment – direct attachment with  $i = 1$**

The motor is attached directly to the compact module's drive end enclosure via a flange.

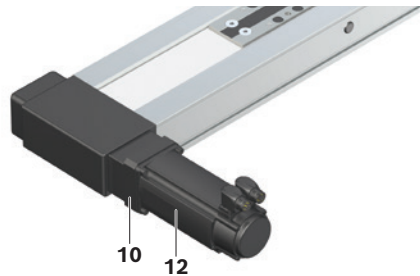

**Motor attachment – with gear**

The planetary gear is attached by means of a flange. The flange serves to fasten the gearbox to the CRK and as a closed housing. Due to the connection without coupling, the drive torque is transferred to the drive shaft of the compact module in a torsionally stiff manner.

Available gear ratios:  $i = 3$  (for CKR-145 and CKR-200)  
 $i = 5, i = 10$

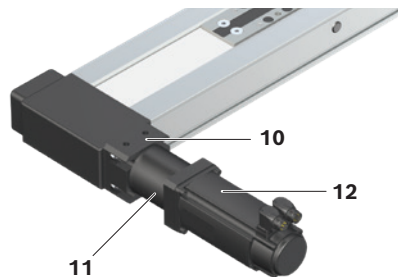

Technical data

**General technical data**

Observe the "Project planning/calculation" chapter.

CKR	Carriage Connection plate		Additional length		Min. travel range	Max. length	Dynamic characteristic values		
	without <sup>1)</sup>	with <sup>2)</sup>	without	with			Load capacities	Load moments	
	L <sub>ca</sub> (mm)	L <sub>ca</sub> (mm)	L <sub>ad</sub> (mm)	L <sub>ad</sub> (mm)	S <sub>min</sub> <sup>3)</sup> (mm)	L <sub>max</sub> (mm)	C <sub>gw</sub> (N)	M <sub>t</sub> (Nm)	M <sub>L</sub> (Nm)
-070	80	60	10	30	40	1,500	2,360	47	7
	108	95	10	23			3,830	77	94
-090	102	60	25	67	40	5,500	4,620	125	16
	156	125	25	56			7,505	203	244
-110	170	110	25	85	50	5,500	19,720	651	136
	215	155	25	85			32,035	1,057	1,361
-145	180	125	25	80	60	5,500	46,800	2,059	400
	240	190	25	75			76,025	3,345	3,801
-200	265	190	25	100	80	10,000	74,600	4,849	1,053
	405	305	25	125			121,185	7,877	10,604

**Drive data**

Observe the "Project planning/calculation" chapter.

CKR	Gearing	Gear ratio	Max. drive torque	Feed constant	Max. speed	Carriage Connection plate		Moved mass of system	
						without	with	without	with
		i (-)	M <sub>p</sub> (Nm)	u (mm/rev)	v <sub>max</sub> (m/s)	L <sub>ca</sub> (mm)	L <sub>ca</sub> (mm)	m <sub>ca</sub> (kg)	m <sub>ca</sub> (kg)
-070	-	1	3.00	72.00	3.00	80	60	0.12	0.23
		5	0.62	14.40	1.92	108	95	0.28	0.45
		10	0.31	7.20	0.96				
-090	-	1	8.00	90.00	3.00	102	60	0.32	0.50
		5	1.65	18.00	3.00	156	125	0.55	0.92
		10	0.82	9.00	1.50				
-110	-	1	13.50	120.00	5.00	170	60	0.52	0.90
		5	2.72	24.00	4.40	215	155	0.87	1.45
		10	1.26	12.00	2.20				
-145	-	1	32.50	165.00	5.00	180	125	0.99	1.80
		3	11.00	55.00	5.00	240	190	1.67	2.82
		5	6.70	33.00	5.00				
		10	3.35	16.50	2.92				
-200	-	1	112.70 99.80 <sup>6)</sup>	250.00	5.00	265	190	2.40	4.60
		3	38.73	83.33	5.00	405	305	4.30	7.90
		5	20.62	50.00	5.00				
		10	9.28	25.00	2.92				
		3	38.73	83.33	5.00	405	305	4.30	7.90
		5	23.24	50.00	5.00				
		10	11.62	25.00	2.50				

- 1) In the "without connection plate" carriage version, carriage length L<sub>ca</sub> corresponds to the length of the clamping surface.
- 2) The connection plate is mounted on the "without connection plate" carriage version.  
 In the "with connection plate" carriage version, the carriage length corresponds to the length of the connection plate.
- 3) Minimum required travel range to ensure a reliable lubrication distribution.
- 4) Maximum force that can be transmitted via the teeth meshing with the belt pulley.
- 5) The maximum permissible tensile load on the belt cross section (belt elasticity limit) is given here for easier comparability.  
 This value represents the load limit in terms of plastic deformation and may not be used to calculate the maximum permissible drive torque.
- 6) Version with keyway

Maximum permissible loads							Planar moments of inertia		Point of force application	
Moments			Forces				$I_y$ (cm <sup>4</sup> )	$I_z$ (cm <sup>4</sup> )	Connection plate	
$M_x$ max (Nm)	$M_y$ max (Nm)	$M_z$ max (Nm)	$F_y$ max (N)	$F_{z1}$ max (N)	$F_{z2}$ max (N)	$Z_1$ (mm)			$Z_1$ (mm)	
47	7	7	1,270	2,360	2,360	5.62	51.6	20.0	32.5	
77	94	51	2,070	3,830	3,830					
112	16	16	2,490	4,620	4,620	13.49	139.6	24.0	40.0	
203	244	132	4,050	7,505	7,505					
198	32	32	3,480	6,000	6,000	36.31	361.2	28.7	44.7	
396	510	240	5,650	12,000	12,000					
634	100	100	8,410	14,400	14,400	91.30	1047.0	37.5	57.5	
1,267	1,440	683	13,660	28,800	28,800					
1,375	299	299	12,265	21,150	21,150	498.00	3,836.0	45.5	72.5	
2,750	3,701	1,744	19,925	42,300	42,300					

Constant mass calculation		Constant mass moment of inertia				Friction torque $M_{Rs}$ (Nm)	Belt pulley diameter $d_3$ (mm)	Belt type $B_t$	Max. belt drive transmission force $F_{bp}^{4)}$ (N)	Belt elasticity limit $F_{t perm}^{5)}$ (N)	Max. acceleration $a_{max}$ (m/s <sup>2</sup> )
$k_g$ fix (kg)	$k_g$ var (kg/mm)	Connection plate		$k_{J var}$ (kg/mm)	$k_{J m}$ (mm <sup>2</sup> )						
		without $k_{J fix}$ (kg/mm <sup>2</sup> )	with $k_{J fix}$ (kg/mm <sup>2</sup> )								
0.50	0.00284	22.32	36.77	0.0142	131.11	0.23	22.92	25 AT3	260	1,100	
		43.14	65.46			0.25					
0.70	0.00440	92.45	129.38	0.0320	205.21	0.57	28.65	35 AT3	560	1 600	
		139.64	215.57			0.58					
1.27	0.00739	266.45	405.08	0.1364	364.81	1.04	38.20	50 AT5	705	4 200	
		391.07	602.66			1.42					
2.54	0.01222	1,024.28	1,582.85	0.3172	689.59	1.46	52.52	70 AT5	1,235	4 800	
		1,621.61	2,276.71			2.04					
7.83	0.02328	6,140.67	9,623.81	1.8397	1,583.24	4.55	79.58	100 AT10	2,830	17,000	
		9,020.05	14,719.73			5.69					

50

**Gear data**

Observe the "Project planning/calculation" chapter.

CKR	Gearing Type	Gear ratio <i>i</i> (-)	Max. acceleration torque <sup>1)</sup> (at the gear output)	Base frictional torque	Max. drive speed
			<i>M</i> <sub>ge</sub> (Nm)	<i>M</i> <sub>Rge</sub> (Nm)	<i>n</i> <sub>ge</sub> (min <sup>-1</sup> )
<b>-070</b>	PG040	5	14.0	0.06	9,000
		10	13.0	0.05	9,000
<b>-090</b>	PG050	5	14.0	0.09	10,000
		10	13.0	0.08	10,000
<b>-110</b>	PG050	5	14.0	0.09	10,000
		10	13.0	0.08	10,000
<b>-145</b>	PG070	3	32.0	0.24	8,000
		5	40.0	0.17	8,000
		10	35.0	0.12	8,000
<b>-200</b>	PG090	3	125.0	0.38	7,000
		5	100.0	0.26	
		10	90.0	0.17	
	PG120	3	200.0	1.00	6,000
		5	250.0	0.76	
		10	220.0	0.58	

<sup>1)</sup> The limits of the linear motion system must not be exceeded → "Drive data / project planning/calculation".





Motor	Mass moment of inertia	Weight	
		$J_{ge}$ (kgm <sup>2</sup> )	$m_{ge}$ (kg)
MS2N03-B	0.000004		0.50
MSM019-B			
MS2N03-B	0.000003		
MSM019-B			
MS2N03-B	0.0000030		0.80
MS2N03-D	0.0000050		0.80
MSM031-C	0.0000130		1.30
MS2N03-B	0.0000020		0.80
MS2N03-D	0.0000040		0.80
MSM031-C	0.0000130		1.30
MS2N03-B	0.0000030		0.90
MS2N03-D	0.0000050		0.90
MS2N04	0.0000130		1.40
MSM031-C	0.0000130		1.40
MS2N03-B	0.0000020		0.90
MS2N03-D	0.0000040		0.90
MS2N04	0.0000130		1.40
MSM031-C	0.0000130		1.40
MS2N04	0.0000320		2.10
MS2N05	0.0000530		3.20
MSM041-B	0.0000530		3.20
MS2N04	0.0000270		2.10
MS2N05	0.0000460		3.20
MSM041-B	0.0000460		3.20
MS2N04	0.0000220		2.10
MS2N05	0.0000430		3.20
MSM041-B	0.0000430		3.20
MS2N06	0.0001800		4.4
	0.0001600		
	0.0001500		
MS2N07	0.0007200		17.30
	0.0005900		
	0.0005400		

Configuration, order

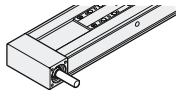
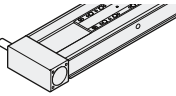
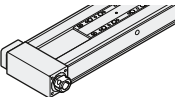
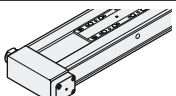
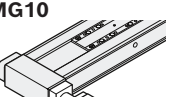
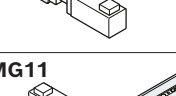
**CKR-070**

Short product name, length <sup>1)</sup> CKR-070-NN-1, ... mm		Guideway		Drive		Lubrication <sup>3)</sup>	Carriage										
		Standard	Centering holes <sup>2)</sup>	without keyway	for gear unit <sup>4)</sup>		Connection plate without		with								
Version				i = 1			L <sub>ca</sub> = (mm)		L <sub>ca</sub> = (mm)								
							80	108	60	95							
Drive journal	MA01 	01	03	04	01	LSS	01	02	40	41							
	MA02 				02												
Clamping hub	MA05 				07						08	09	LPG	-	302	-	341
	MA06 																
Gear attachment	MG10 				-						-	-	-	-	-	-	-
	MG11 																

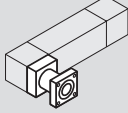
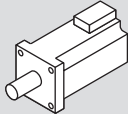
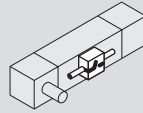
- 1) Length calculation of the linear motion system ⇒ "Project planning/calculation" chapter.
- 2) Centering holes for simple combination with other linear motion systems and connection elements (⇒ Dimension drawings).  
Option 03: with centering holes and fastening threads in the ground area of the frame.  
Option 04: with centering holes and long hole in the ground area of the frame. Selectable starting from length L ≥ 300 mm up to length L<sub>max</sub>
- 3) Lubrication ⇒ Chapter "Lubrication".
- 4) Attachment kit for gear attachment
- 5) If a module has been ordered with an attached servo motor, it will only be delivered with the motor mounting shown in the chapter "Form of delivery" (note position of motor connector).
- 6) Recommended motor, motor data and type designations ⇒ Chapter "Motors"
- 7) More information ⇒ Chapter "Switching system".
- 8) Assembly contains 1 x sensor, 1 x switch mounting plate including set screws and square nuts as well as 3 x cable holders including set screws
- 9) Measurement report: 01 = Standard report; 02 = Measurement of frictional torque; (⇒ Chapter "Documentation")
- 10) Motor attachment consisting of: Adapter flange for gear unit, however "without gear unit". No motor connector position selectable.

Motor attachment <sup>5)</sup>		Motor <sup>6)</sup>						Switching system <sup>7)</sup>		Automation package			Documentation <sup>9)</sup>			
																
Direct drive		Gearing		Motor code		2 cables		1 cable		Motor connector position		Controller	Cable	Software		
i = 1		i = 5   i = 10				without brake   with brake		without brake   with brake								
MA01										Without						
MA02										- Switch - Cable duct - Socket-connector		00				
MA05		00								Magnetic sensor					01	
MA06										REED, changeover (NC: C+NC, NO: C+NO)		21				
										Hall, PNP normally closed (NC)		22				
										Hall, PNP normally open (NO)		23				
										Cable duct		25				
										Socket-connector		17				
										Magnetic sensor with connector <sup>8)</sup>						
										REED, changeover (NC: C+NC, NO: C+NO)		58				
										Hall, PNP normally closed (NC)		59				
MG10 / MG11		00 <sup>10)</sup>								000						
		11   12		MS2N03-B0BYN		-   -		203   204		090						
		23   24		MSM019B-0300		134   135		-   -		180						
										270					02	

**Drive end enclosure with additional drive journal**

In the versions MA05, MA06, MG10 and MG11, a second drive journal can be made available by removing the screws and cover.

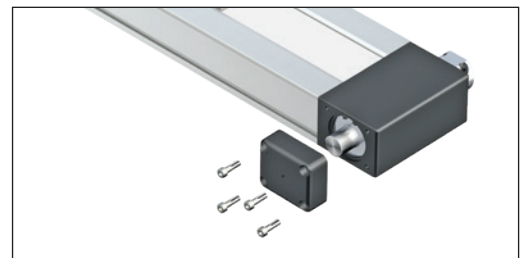

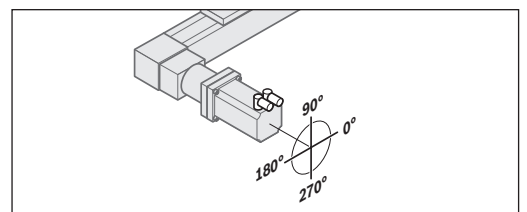

Version	Motor connector position			
	0°	90°	180°	270°
MG10 / MG11	000	090 ★	180	270

★ Standard delivery

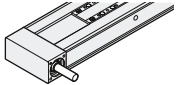

Explanation of the order parameters and ordering example ➔ Chapter "Ordering example".

**CKR-090**

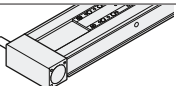
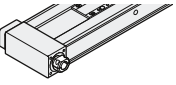
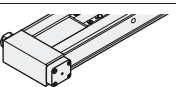
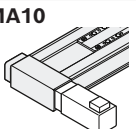
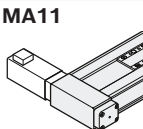
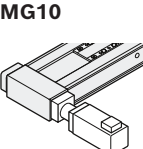
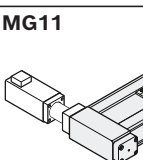
Short product name, length <sup>1)</sup> CKR-090-NN-1, ... mm		Guideway		Drive			Lubrication <sup>3)</sup>	Carriage												
		Standard	Centering holes <sup>2)</sup>	without keyway	with keyway	for gear unit <sup>4)</sup>		Connection plate without		with										
Version				i = 1	i = 1			L <sub>ca</sub> = (mm)		L <sub>ca</sub> = (mm)										
								102	156	60	125									
Drive journal	MA01 	01	03	04				LSS	01	02	40	41								
	MA02 				01	03														
Clamping hub	MA05 															LPG	-	302	-	341
	MA06 				06	-							-							
Direct attachment	MA10 															LCF		-		141
	MA11 				06	-							-							
Gear attachment	MG10 															LCO		-		241
	MG11 				-	-							08							

- 1) Length calculation of the linear motion system ⇒ "Project planning/calculation" chapter.
- 2) Centering holes for simple combination with other linear motion systems and connection elements (⇒ Dimension drawings).  
Option 03: with centering holes and fastening threads in the ground area of the frame. Selectable up to a length of L ≤ 2000 mm  
Option 04: with centering holes and long hole in the ground area of the frame. Selectable starting from length L ≥ 300 mm up to length L<sub>max</sub>
- 3) Lubrication ⇒ Chapter "Lubrication".
- 4) Attachment kit for gear attachment
- 5) If a module has been ordered with an attached servo motor, it will only be delivered with the motor mounting shown in the chapter "Form of delivery" (note position of motor connector).
- 6) Recommended motor, motor data and type designations ⇒ Chapter "Motors"
- 7) More information ⇒ Chapter "Switching system".
- 8) Assembly contains 1 x sensor, 1 x switch mounting plate including set screws and square nuts as well as 3 x cable holders including set screws
- 9) Measurement report: 01 = Standard report; 02 = Measurement of frictional torque; (⇒ Chapter "Documentation")
- 10) Motor attachment consisting of: Adapter flange for gear unit, however "without gear unit". No motor connector position selectable.

Motor attachment <sup>5)</sup>			Motor <sup>6)</sup>						Switching system <sup>7)</sup>		Automation package			Docu- menta- tion <sup>9)</sup>	
Direct drive		Gearing		Motor code	2 cables		1 cable		Motor connector position			Controller	Cable	Software	
i = 1	i = 5	i = 10	without brake		with brake	without brake	with brake								
MA01	MA02	MA05	MA06	00		00		000		Without		"Automation package" chapter	01	02	
										- Switch					00
										- Cable duct					
										- Socket-connector					
								Magnetic sensor		21					
								REED, changeover (NC: C+NC, NO: C+NO)							
								Hall, PNP normally closed (NC)			22				
								Hall, PNP normally open (NO)							
								Cable duct			25				
								Socket-connector							
										Magnetic sensor with connector <sup>8)</sup>		58			
								REED, changeover (NC: C+NC, NO: C+NO)							
								Hall, PNP normally closed (NC)							
										59					
MA10 / MA11	01	-		MS2N04-D0BQN	-	-	219	220	000			"Automation package" chapter	02		
MG10 / MG11	-	00 <sup>10)</sup>		00				090							
		15	16	MS2N03-B0BYN	-	-	203	204	180	58					
		13	14	MS2N03-D0BYN	-	-	207	208	270						
		33	34	MSM031C-0300	138	139	-	-							

**Drive end enclosure with additional drive journal**

In the versions MA05, MA06, MA10, MA11, MG10 and MG11, a second drive journal can be made available by removing the screws and cover.

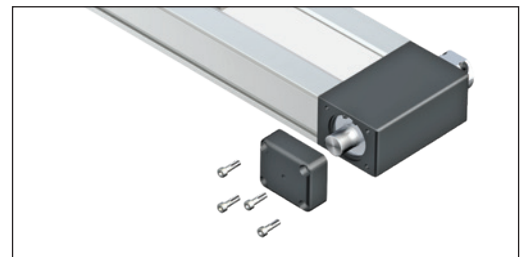

Version	Motor connector position			
	0°	90°	180°	270°
MA10 / MA11 MG10 / MG11	000	090 ★	180	270

★ Standard delivery

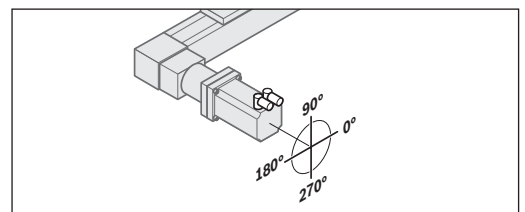

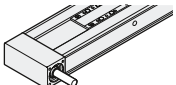
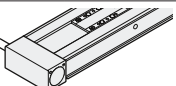
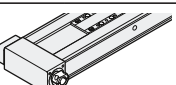
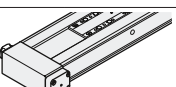
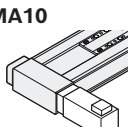
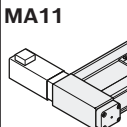
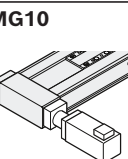
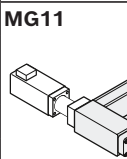

**Explanation of the order parameters and ordering example** ⇒ Chapter "Ordering example".

**CKR-110**

Short product name, length <sup>1)</sup> CKR-110-NN-1, ... mm		Guideway		Drive			Lubrication <sup>3)</sup>	Carriage							
		Standard	Centering holes <sup>2)</sup>	without keyway	with keyway	for gear unit <sup>4)</sup>		Connection plate without L <sub>ca</sub> = (mm)	with L <sub>ca</sub> = (mm)						
Version				i = 1	i = 1			170	215	110	155				
Drive journal	MA01 	01	03	04			LSS								
	MA02 				01	03				01	02	40	41		
Clamping hub	MA05 										LPG				
	MA06 				06	-		-		-		-	302	-	341
Direct attachment	MA10 										LCF				
	MA11 				06	-		-		-		-			141
Gear attachment	MG10 										LCO				
	MG11 				-	-		08		-		-			241

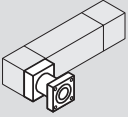
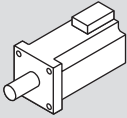
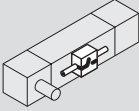
- 1) Length calculation of the linear motion system ⇒ "Project planning/calculation" chapter.
- 2) Centering holes for simple combination with other linear motion systems and connection elements (⇒ Dimension drawings).  
Option 03: with centering holes and fastening threads in the ground area of the frame. Selectable up to a length of L ≤ 2000 mm  
Option 04: with centering holes and long hole in the ground area of the frame. Selectable starting from length L ≥ 300 mm up to length L<sub>max</sub>
- 3) Lubrication ⇒ Chapter "Lubrication".
- 4) Attachment kit for gear attachment
- 5) If a module has been ordered with an attached servo motor, it will only be delivered with the motor mounting shown in the chapter "Form of delivery" (note position of motor connector).
- 6) Recommended motor, motor data and type designations ⇒ Chapter "Motors"
- 7) More information ⇒ Chapter "Switching system".
- 8) Assembly contains 1 x sensor, 1 x switch mounting plate including set screws and square nuts as well as 3 x cable holders including set screws
- 9) Measurement report: 01 = Standard report; 02 = Measurement of frictional torque; (⇒ Chapter "Documentation")
- 10) Motor attachment consisting of: Adapter flange for gear unit, however "without gear unit". No motor connector position selectable.

Motor attachment <sup>5)</sup>			Motor <sup>6)</sup>					Switching system <sup>7)</sup>		Automation package		Documentation <sup>9)</sup>	
													
Direct drive	Gearing		Motor code	2 cables		1 cable		Motor connector position	Controller	Cable	Software		
i = 1	i = 5	i = 10		without brake	with brake	without brake	with brake						
MA01								Without				01	
MA02								- Switch	00				
MA05	00		00					Magnetic sensor					
MA06								REED, changeover (NC: C+NC, NO: C+NO)	21				
MA10 / MA11	01	-	MS2N05-D0BRN	-	-	231	232	000	Hall, PNP normally closed (NC)	22	"Automation package" chapter		02
								090	Hall, PNP normally open (NO)	23			
									Cable duct	25			
									Socket-connector	17			
									Magnetic sensor with connector <sup>8)</sup>				
									REED, changeover (NC: C+NC, NO: C+NO)	58			
									Hall, PNP normally closed (NC)	59			
MG10 / MG11	-	00 <sup>10)</sup>	00										
		15	16	MS2N03-B0BYN	-	-	203	204	180				
		13	14	MS2N03-D0BYN	-	-	207	208					
		23	24	MS2N04-B0BTN	-	-	211	212	270				
				MS2N04-C0BTN	-	-	215	216					
		33	34	MSM031C-0300	138	139	-	-					

**Drive end enclosure with additional drive journal**

In the versions MA05, MA06, MA10, MA11, MG10 and MG11, a second drive journal can be made available by removing the screws and cover.

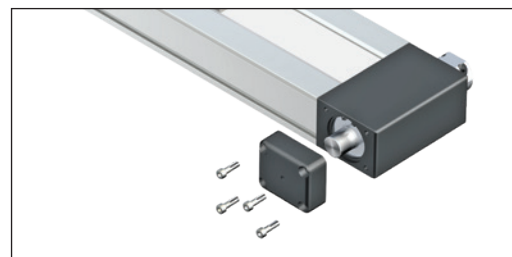

Version	Motor connector position			
	0°	90°	180°	270°
MA10 / MA11 MG10 / MG11	000	090 ★	180	270

★ Standard delivery

Explanation of the order parameters and ordering example → Chapter "Ordering example".

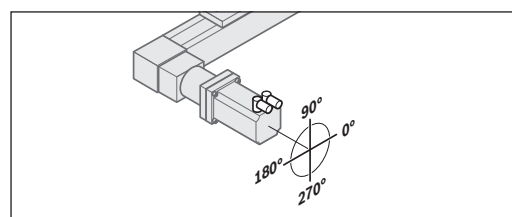

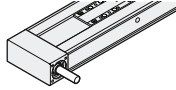
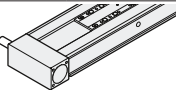
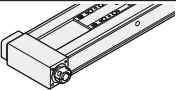
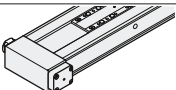
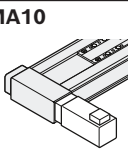
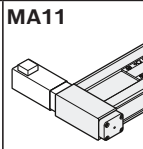
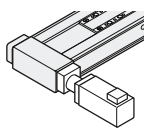
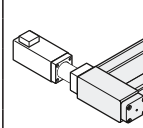

**CKR-145**

Short product name, length <sup>1)</sup> CKR-145-NN-1, ... mm		Guideway		Drive			Lubrication <sup>3)</sup>	Carriage						
		Standard	Centering holes <sup>2)</sup>	without keyway i = 1	with keyway i = 1	for gear unit <sup>4)</sup>		Connection plate		without L <sub>ca</sub> = (mm)	with L <sub>ca</sub> = (mm)			
Version								180	240	125	190			
Drive journal	MA01 	01	03	04			LSS							
	MA02 				01	03		-	01	02	40	41		
Clamping hub	MA05 									LPG				
	MA06 				06	-		-	-		302	-	341	
Direct attachment	MA10 									LCF				
	MA11 				06	-		-	-		-	141		
Gear attachment	MG10 									LCO				
	MG11 				-	-		08	-		-	241		

- 1) Length calculation of the linear motion system → "Project planning/calculation" chapter.
- 2) Centering holes for simple combination with other linear motion systems and connection elements (→ Dimension drawings).  
Option 03: with centering holes and fastening threads in the ground area of the frame. Selectable up to a length of L ≤ 2000 mm  
Option 04: with centering holes and long hole in the ground area of the frame. Selectable starting from length L ≥ 300 mm up to length L<sub>max</sub>
- 3) Lubrication → Chapter "Lubrication".
- 4) Attachment kit for gear attachment
- 5) If a module has been ordered with an attached servo motor, it will only be delivered with the motor mounting shown in the chapter "Form of delivery" (note position of motor connector).
- 6) Recommended motor, motor data and type designations → Chapter "Motors"
- 7) More information → Chapter "Switching system".
- 8) Assembly contains 1 x sensor, 1 x switch mounting plate including set screws and square nuts as well as 3 x cable holders including set screws
- 9) Measurement report: 01 = Standard report; 02 = Measurement of frictional torque; (→ Chapter "Documentation")
- 10) Motor attachment consisting of: Adapter flange for gear unit, however "without gear unit". No motor connector position selectable.

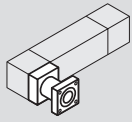
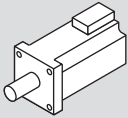
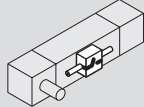

Motor attachment <sup>5)</sup>				Motor <sup>6)</sup>					Switching system <sup>7)</sup>		Automation package			Docu- menta- tion <sup>9)</sup>		
 Direct drive i = 1 Gearing i = 3   i = 5   i = 10				 Motor code 2 cables without brake   with brake 1 cable without brake   with brake Motor connector position					 Without - Switch   00 - Cable duct - Socket-connector Magnetic sensor REED, changeover (NC: C+NC, NO: C+NO)   21 Hall, PNP normally closed (NC)   22 Hall, PNP normally open (NO)   23 Cable duct   25 Socket-connector   17 Magnetic sensor with connector <sup>8)</sup> REED, changeover (NC: C+NC, NO: C+NO)   58 Hall, PNP normally closed (NC)   59		Controller Cable Software					
MA01	00			00							"Automation package" chapter			01		
MA02																
MA05																
MA06																
MA10 / MA11	01	-	-	-	MS2N06-D1BNN	-	-	247	248	000						02
MG10 / MG11	-	00 <sup>10)</sup>			00				090							
		13	14	15	MS2N04-C0BTN	-	-	215	216	180						
					MS2N04-D0BQN	-	-	219	220							
		43	44	45	MS2N05-B0BTN	-	-	223	224	270						
					MS2N05-C0BTN	-	-	227	228							
		33	34	35	MS2N05-D0BRN	-	-	231	232							
					MSM041B-0300	140	141	-	-							

**Drive end enclosure with additional drive journal**

In the versions MA05, MA06, MA10, MA11, MG10 and MG11, a second drive journal can be made available by removing the screws and cover.

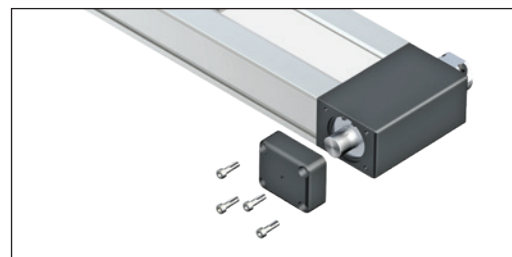

Version	Motor connector position			
	0°	90°	180°	270°
MA10 / MA11 MG10 / MG11	000	090 ★	180	270

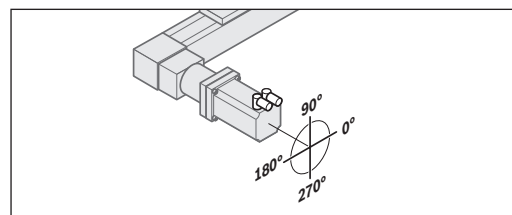



★ Standard delivery

Explanation of the order parameters and ordering example ➔ Chapter "Ordering example".

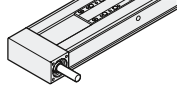
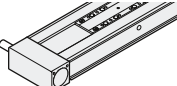
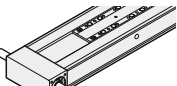
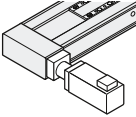
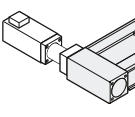
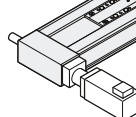
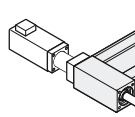
**CKR-200**

Short product name, length <sup>1)</sup> CKR-200-NN-1, ... mm		Guideway		Drive			Lubrication <sup>3)</sup>	Carriage						
		Standard	Centering holes <sup>2)</sup>	without keyway	with keyway	for gear unit <sup>4)</sup>		Connection plate without		with				
Version				i = 1	i = 1			L <sub>ca</sub> = (mm)		L <sub>ca</sub> = (mm)				
Drive journal	MA01 	01	03	04			-	LSS	01	02	40	41		
	MA02 				01	03								
	MA03 				02	04				LPG	-	302	-	341
Gear attachment	MG01 	01	03	04			-	LCF	-	-	-	141		
	MG02 												PG090 10	
	MG03 									LCO	-	-	-	241
	MG04 													

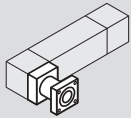
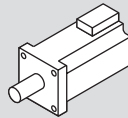
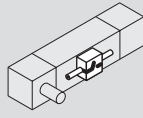
1) Length calculation of the linear motion system ⇒ "Project planning/calculation" chapter.  
 2) Centering holes for simple combination with other linear motion systems and connection elements (⇒ Dimension drawings).  
 Option 03: with centering holes and fastening threads in the ground area of the frame. Selectable up to a length of L ≤ 2000 mm  
 Option 04: with centering holes and long hole in the ground area of the frame. Selectable up to a length of L ≤ 5500 mm  
 3) Lubrication ⇒ Chapter "Lubrication".  
 4) Attachment kit for gear attachment  
 5) If a module has been ordered with an attached servo motor, it will only be delivered with the motor mounting shown in the chapter "Form of delivery" (note position of motor connector).  
 6) Recommended motor, motor data and type designations ⇒ Chapter "Motors"  
 7) More information ⇒ Chapter "Switching system".  
 8) Assembly contains 1 x sensor, 1 x switch mounting plate including set screws and square nuts as well as 3 x cable holders including set screws  
 9) Switch configuration with magnetic sensor and mechanical/proximity switch together on one side is not possible.  
 Assembly contains 1 x sensor, 1 x switch mounting plate including mounting material  
 10) Switching cam can be attached only in conjunction with connection plate  
 11) Measurement report: 01 = Standard report; 02 = Measurement of frictional torque; 03 = Lead deviation (⇒ Chapter "Documentation")  
 12) Motor attachment consisting of: Adapter flange for gear unit, however "without gear unit". No motor connector position selectable.

Motor attachment <sup>5)</sup>					Motor <sup>6)</sup>					Switching system <sup>7)</sup>		Automation package			Docu- menta- tion <sup>11)</sup>				
 Gearing i = 3    i = 5    i = 10					 Motor code					2 cables		1 cable				Controller Cable Software			
										without brake	with brake	without brake	with brake						
MA01	MA02	MA03	00			00					Without		"Automation package" chapter ↳			01			
											- Switch	00							
											- Cable duct								
- Socket-connector																			
Magnetic sensor																			
REED, changeover (NC: C+NC, NO: C+NO)	21																		
Hall, PNP normally closed (NC)	22																		
Hall, PNP normally open (NO)	23																		
Cable duct	25																		
Socket-connector	17																		
MG01 / MG02 / MG03 / MG04	PG090	00 <sup>12)</sup>			00					Magnetic sensor with connector <sup>8)</sup>		"Automation package" chapter ↳			02				
		43	44	45	MS2N06-D1BNN	-	-	247	248	000	REED, changeover (NC: C+NC, NO: C+NO)					58			
	PG120	33	34	35	MS2N07-B1BNN	-	-	255	256	090	Hall, PNP normally closed (NC)					59			
					Proximity / mechanical switches <sup>9)</sup>														
					Mechanical	15													
					Proximity – PNP NC contact	11													
	MS2N07-C1BRN	-	-	263	264	180	Proximity – PNP NO contact	13											
	MS2N07-D1BNN	-	-	269	270	270	Cable duct	20											
	Switching	1	16																
	cam <sup>10)</sup>	2	26																
Socket-connector	17																		

Version	Motor connector position			
	0°	90°	180°	270°
MG01-MG04	000	090 ★	180	270

★ Standard delivery

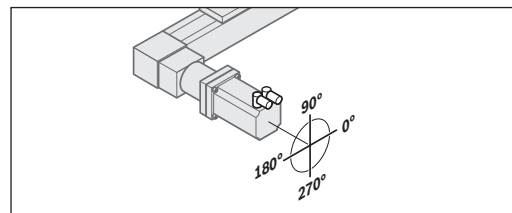

Explanation of the order parameters and ordering example ⇒ Chapter "Ordering example".

**Frame CKR-070/-090/-110/-145**

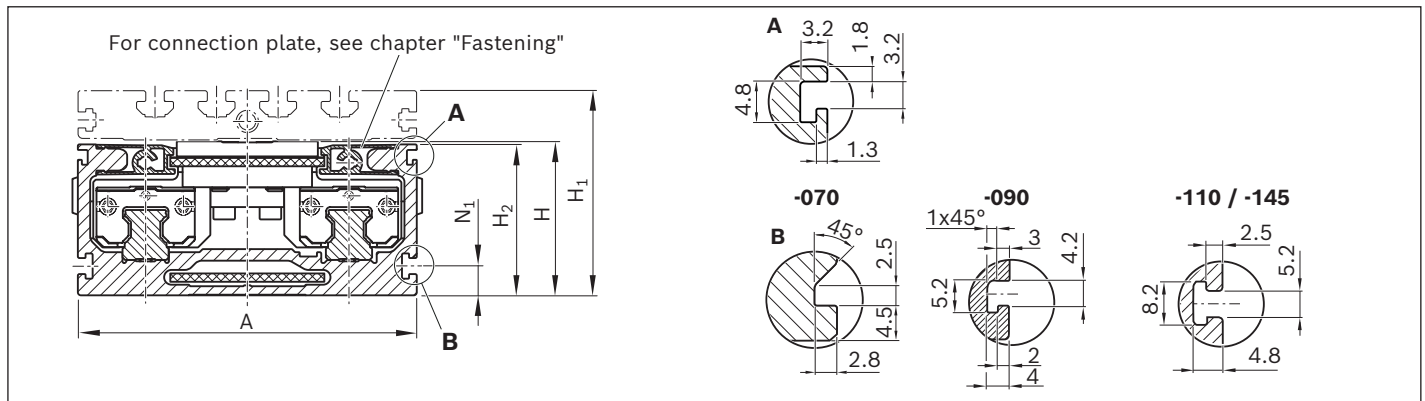
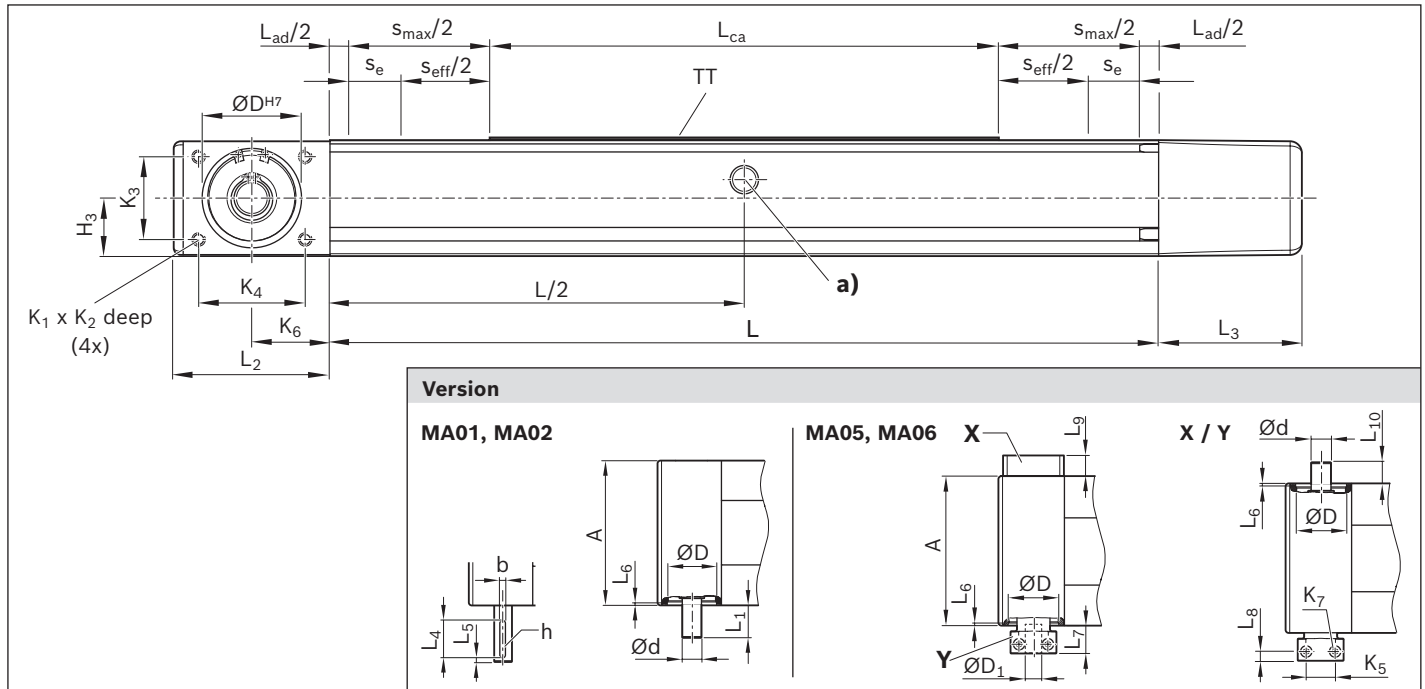

CKR	Dimensions (mm)													
	A	B	b <sup>P9</sup>	H	H <sub>1</sub>	H <sub>2</sub>	H <sub>3</sub>	h	ØD <sup>H7</sup>	ØD <sub>1</sub> <sup>H7</sup>	h7	Ød <sup>h6</sup>	K <sub>1</sub>	K <sub>2</sub>
-070	70	-	-	32	44.5	31.3	16.30	-	26.5	10	8	-	M3	6
-090	90	-	3	40	56.0	39.0	19.50	1.8	34.0	14	10	-	M4	8
-110	110	-	5	50	66.0	49.0	24.50	3.0	42.0	19	14	-	M5	10
-145	145	-	6	65	85.0	64.0	32.00	3.5	49.0	24	19	-	M6	12
-200	200	150	8	100	127.0	98.5	49.25	4.0	68.0	-	-	24	M8	15

**a)** Lube port on both sides (grease lubrication). ➔ Chapter "Lubrication".

Straightness and flatness tolerance in accordance with DIN EN 12020-2.

Note: all dimensions in mm. Drawings not schematically to scale. Exact contours and dimensions can be found in the CAD model. CAD configurator available on the Internet at [www.boschrexroth.com](http://www.boschrexroth.com) "Product configurators".

**Frame CKR-200**

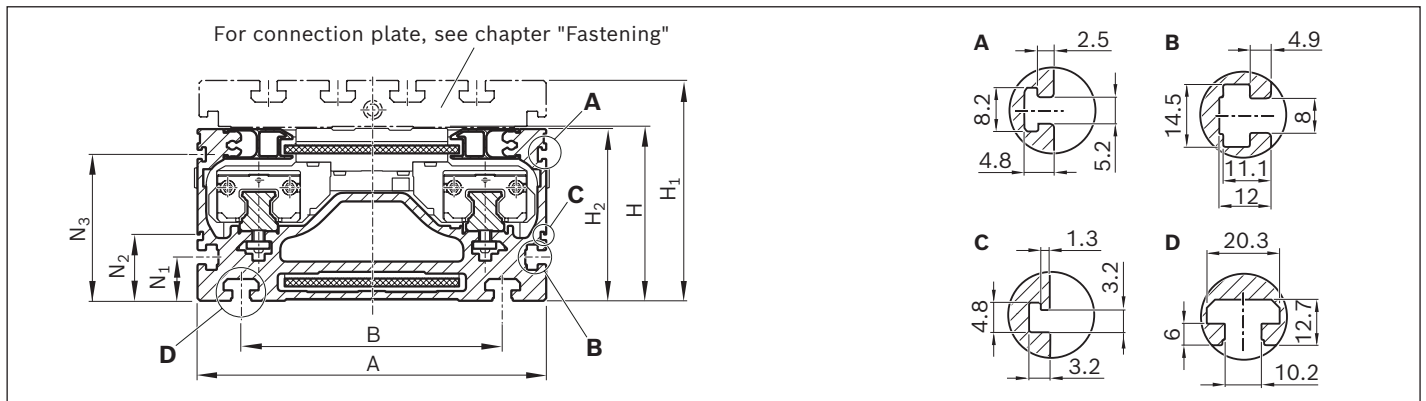
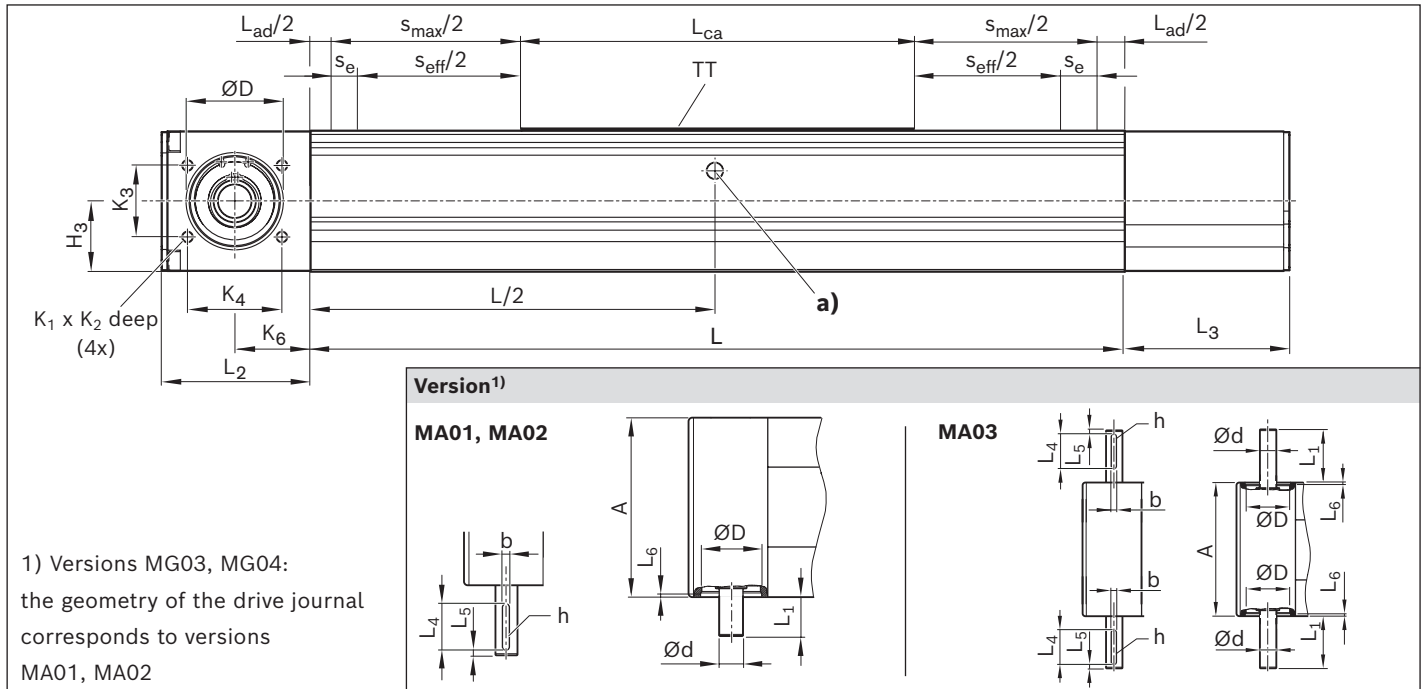

$K_3$	$K_4$	$K_5$ $\pm 0.1$	$K_6$	$K_7$	$L_1$	$L_2$	$L_3$	$L_4$	$L_5$	$L_6$	$L_7$	$L_8$	$L_9$	$L_{10}$	$N_1$	$N_2$	$N_3$
12	29	14.4	18	M2.5 (ISO 4762)	14.5	36	42.0	-	-	3.0	14.5	$5 \pm 0.2$	15	12.0	-	-	-
28	40	20.0	28	M4 (DIN 6912)	31.5	59	49.5	25	2	1.8	20.5	$8 \pm 0.2$	15	12.5	7.6	-	-
35	45	25.0	33	M4 (ISO 4762)	31.5	66	60.5	25	2	2.0	22.0	$8 \pm 0.2$	20	17.5	9.5	-	-
45	45	30.5	30	M5 (ISO 4762)	61.0	64	71.5	40	2	2.5	27.5	$9 \pm 0.1$	20	17.5	9.5	-	-
50	66	-	53	-	61.0	104	115.0	40	3	2.5	-	-	-	-	25.0	38	84

See following pages for dimension drawings for frames, carriages and motor attachment.

Length calculation of the linear motion system ➔ Chapters "Technical data" and "Project planning/calculation".

- A** For switch mounting arrangements
- B** For mounting with clamping fixtures
- C** For cable duct
- D** For fastening with sliding blocks
- TT = Carriage

**Frame CKR-070/-090/-110/-145**

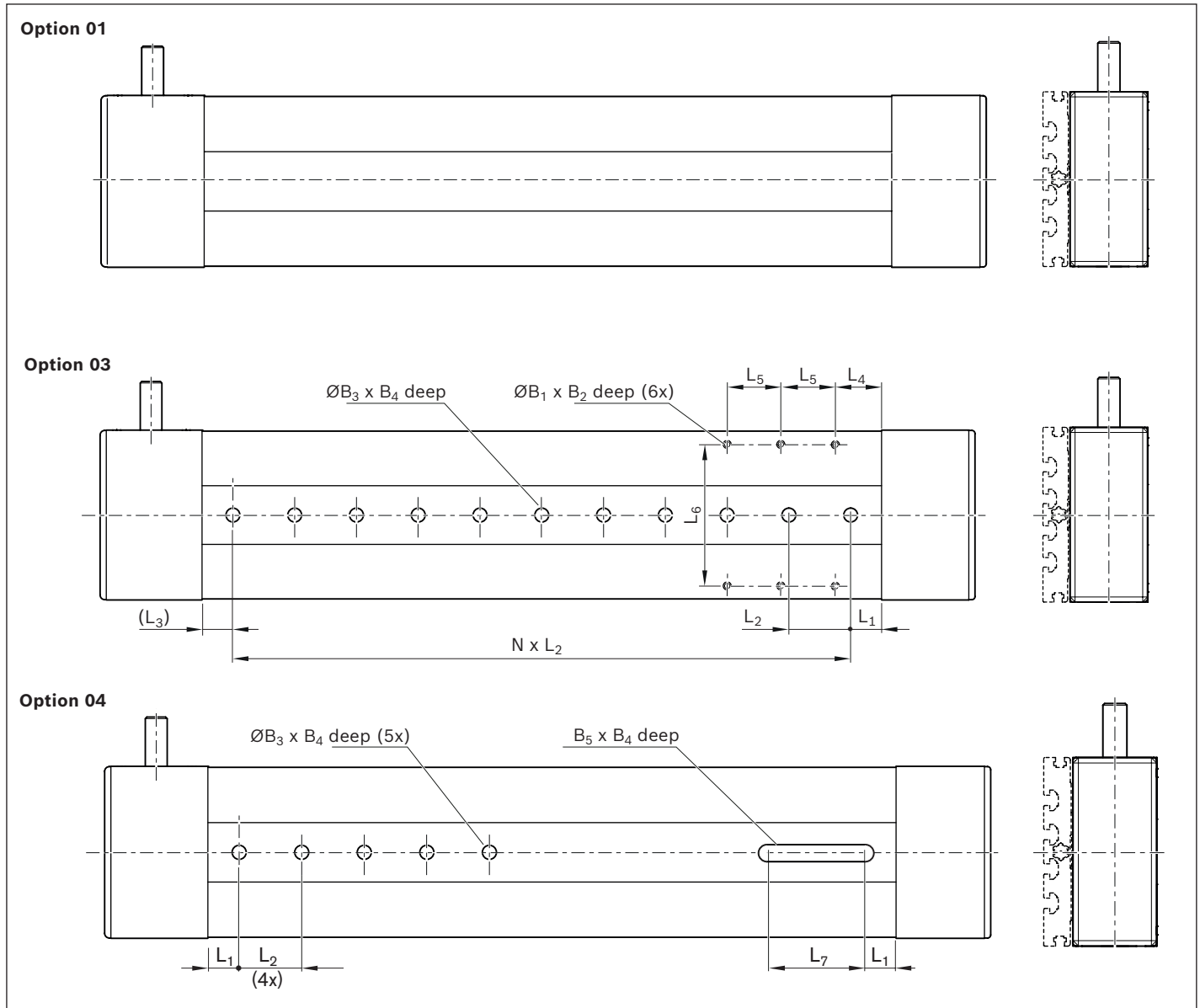

CKR	Option	Dimensions (mm)					L <sub>1</sub>	L <sub>2</sub> ± 0.01	L <sub>3</sub> (min)	L <sub>4</sub>	L <sub>5</sub>	L <sub>6</sub>	L <sub>7</sub>
		B <sub>1</sub>	B <sub>2</sub>	∅B <sub>3</sub> <sup>H7</sup>	B <sub>4</sub>	B <sub>5</sub> <sup>H8</sup>							
-070	03	M3	6.0	7	1.6	-	20	40	10	15	25	59	-
	04	-	-						7	-	-	-	-
-090	03	M4	7.5	9	2.1	-	20	40	10	30	35	76	-
	04	-	-						9	-	-	-	-
-110	03	M5	9.0	9	2.1	-	20	40	10	30	35	92	-
	04	-	-						9	-	-	-	-
-145	03	M6	13.0	12	2.1	-	20	40	10	30	35	124	-
	04	-	-						12	-	-	-	-
-200	03	M8	12.0	16	3.1	-	20	40	10	35	40	119	-
	04	-	-						16	-	-	-	-

**Frame CKR-200**

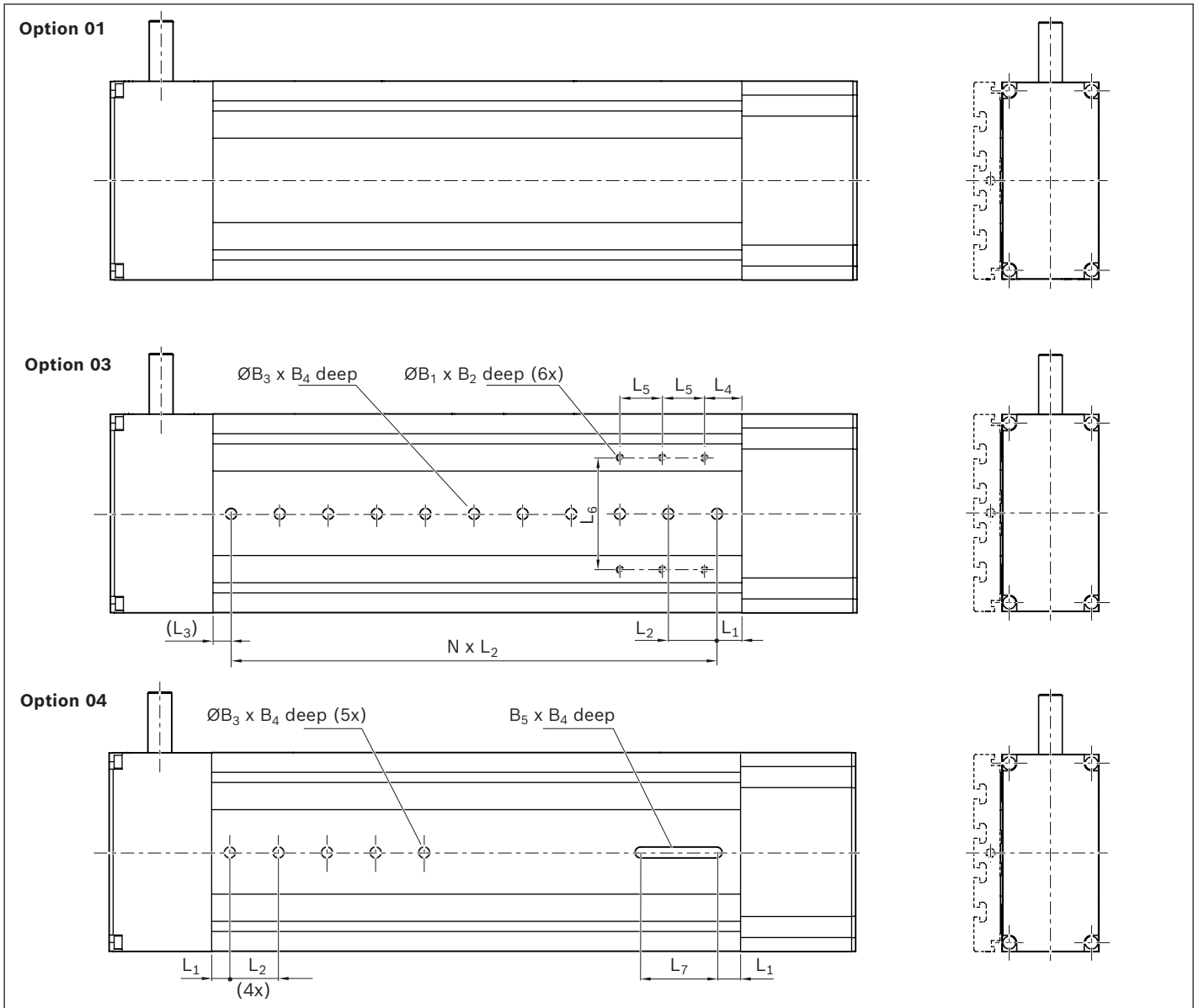

Views from below (ground area)

Option 01 / standard

Option 03 / with centering holes

Option 04 / with centering holes and long hole

**Carriages CKR-070/-090/-110/-145/-200**

**Carriages without connection plate**

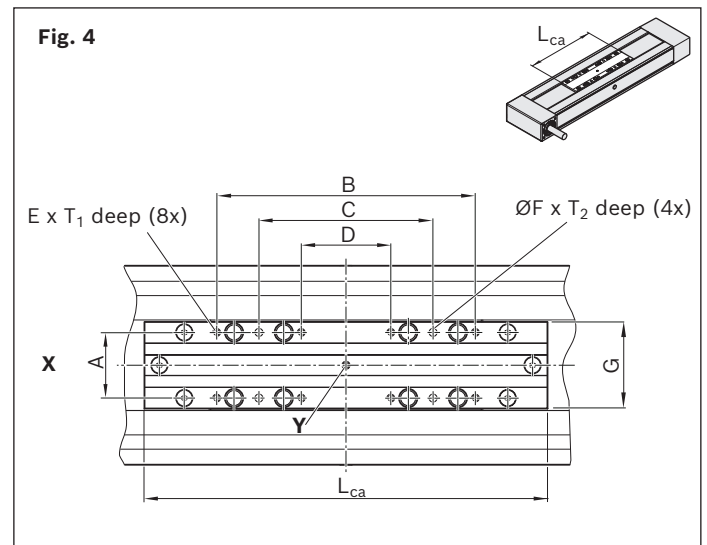
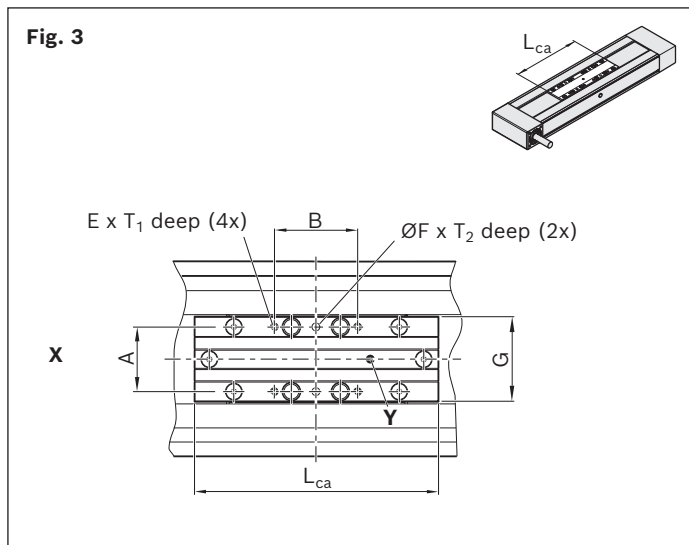
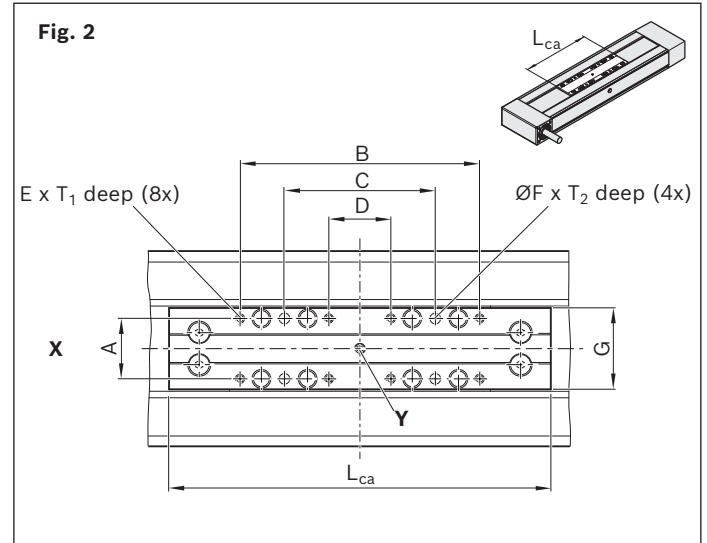
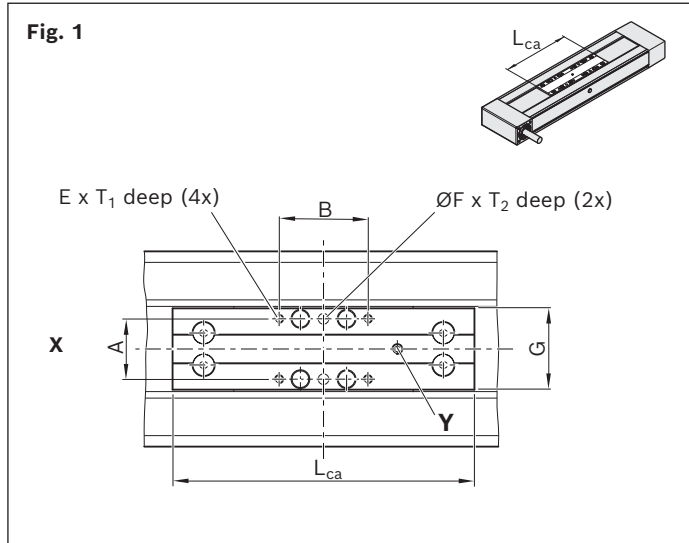

**Carriages with connection plate<sup>1)</sup>**

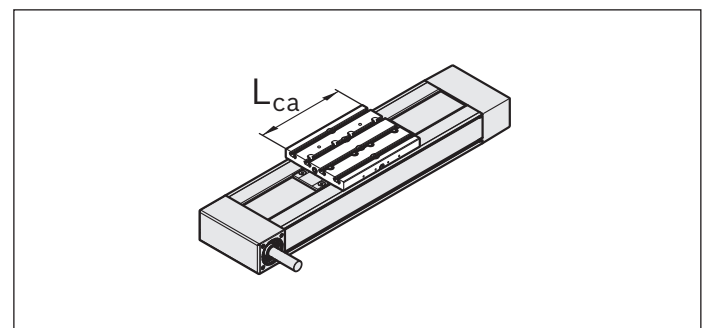
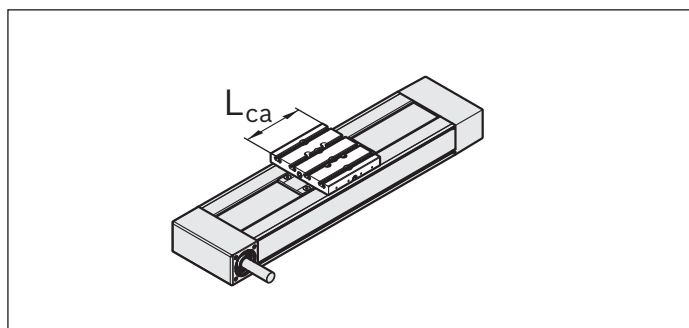

<sup>1)</sup> Dimension drawings → Chapter "Connection plates"



CKR	Figure	Dimensions (mm)									
		L <sub>ca</sub>	A	B	C	D	E	ØF <sup>H7</sup>	G	T <sub>1</sub>	T <sub>2</sub>
<b>-070</b>	1	80	13.5	25	-	-	M3	3	21	6	6
	2	108		65	40	15					
<b>-090</b>	1	102	20	27	-	-	M4	4	27	8	6.5
	2	156		92	65	38					
<b>-110</b>	1	170	34	50	-	-	M5	6	46	10	6.5
	2	215		135	85	35					
<b>-145</b>	1	180	48	60	-	-	M6	6	62	12	7.5
	2	240		160	100	40					
<b>-200</b>	3	265	66	85	-	-	M8	8	87	16	10
	4	405		260	175	90					

- X** Drive side
- Y** Lubrication point for grease; sealed with set screw.  
Supplementary information for lubrication ➡ Chapter "Lubrication".

**Motor attachment CKR-070/-090/-110/-145**

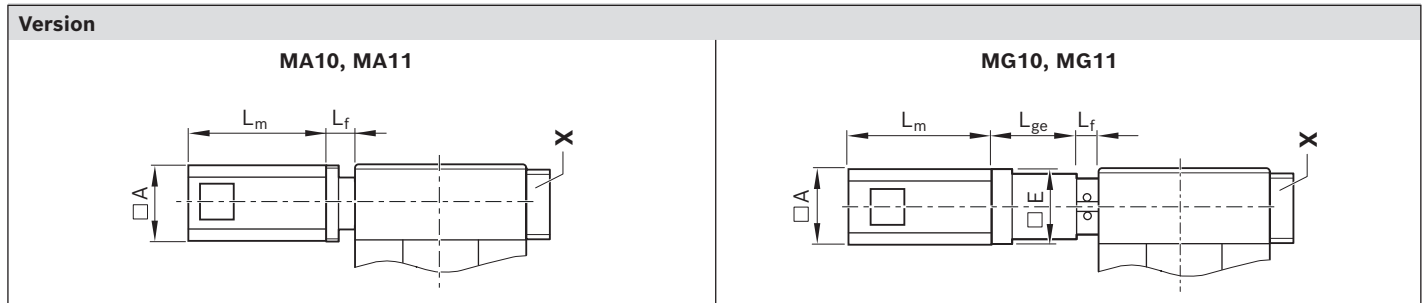

**X: Drive end enclosure with additional drive journal**

In the versions MA10, MA11, MG10 and MG11, a second drive journal can be made available by removing the screws and cover.

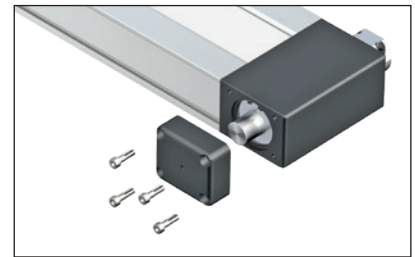

**Motor attachment CKR-200**

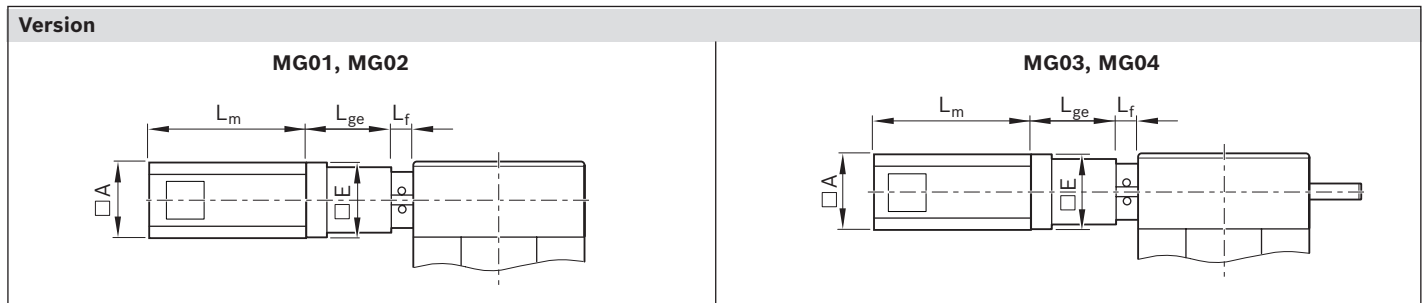

**Motor attachment Option 00 (adapter flange for customer-side gear attachment)**

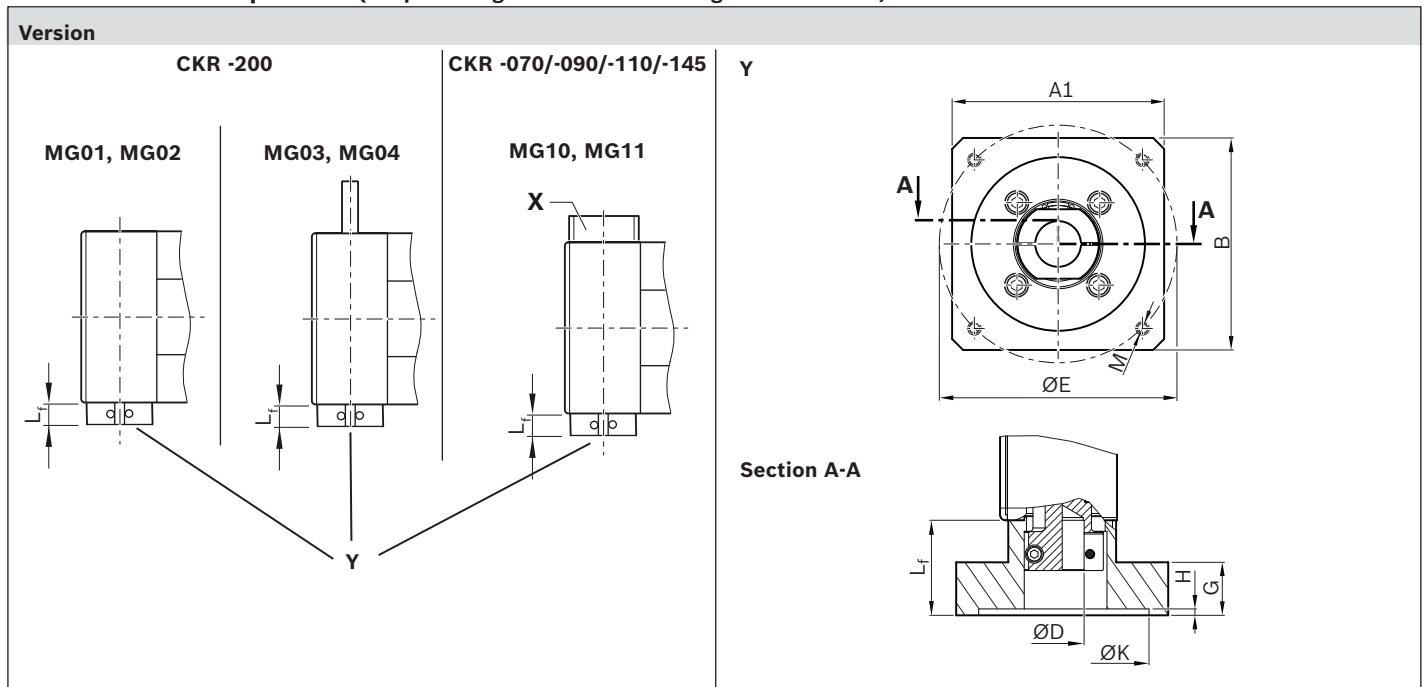

CKR	Version	Motor code	Dimensions (mm)				L <sub>m</sub>	□ A	A1	B	Ø E	G	H	Ø D	Ø K	Ø M
			□ E	L <sub>f</sub>	L <sub>ge</sub>	□ A										
-070	MG10, MG11	MS2N03-B0BYN	55	29.5	60.7	See chapter "Motors"	-	-	Ø 40		34	8.5	2.5	10 <sup>H7</sup>	27 <sup>+0.2</sup>	4.3
		MSM019B-0300	40	-	-				-	-	-	-	-	-	-	-
-090	MA10, MA11	MS2N04-D0BQN	-	34.5	-		-	-	51	51	44	8.5	4.5	14 <sup>H7</sup>	35.1 <sup>+0.3</sup>	4.5
	MG10, MG11	MS2N03-B0BYN	55	28.0	68.0											
		MS2N03-D0BYN	70	-	75.0											
-110	MA10, MA11	MS2N05-D0BRN	55	46.0	-		-	-	57	55	44	-	7 <sup>+0.4</sup>	19 <sup>H7</sup>	35 <sup>H7</sup>	4.5
	MG10, MG11	MS2N03-B0BYN	55	30.5	68.0											
		MS2N03-D0BYN	80	-	75.0											
		MS2N04-B0BTN	80	-	75.0											
		MS2N04-C0BTN	70	-	75.0											
-145	MA10, MA11	MS2N06-D1BNN	55	52.0	-		-	-	72	72	62	13	5.5 <sup>+0.3</sup>	24 <sup>H7</sup>	53 <sup>+0.4</sup>	5.5
	MG10, MG11	MS2N04-C0BTN	80	37.0	92.0											
		MS2N04-D0BQN	100	-	101.0											
		MS2N05-B0BTN	100	-	101.0											
		MS2N05-C0BTN	90	-	97.0											
		MSM041B-0300	90	-	97.0											
-200	MG01, MG02, MG03, MG04	MS2N06-D1BNN	120	45.0	124.5	-	-	95	95	80	-	6	22 <sup>F7</sup>	68.3 <sup>+0.2</sup>	6.6	
		MS2N07-B1BNN	150	75.0	154.0											
		MS2N07-C1BRN	150	75.0	154.0											
		MS2N07-D1BNN	150	75.0	154.0											
		MS2N07-E1BNN	150	75.0	154.0											

Adapter flange

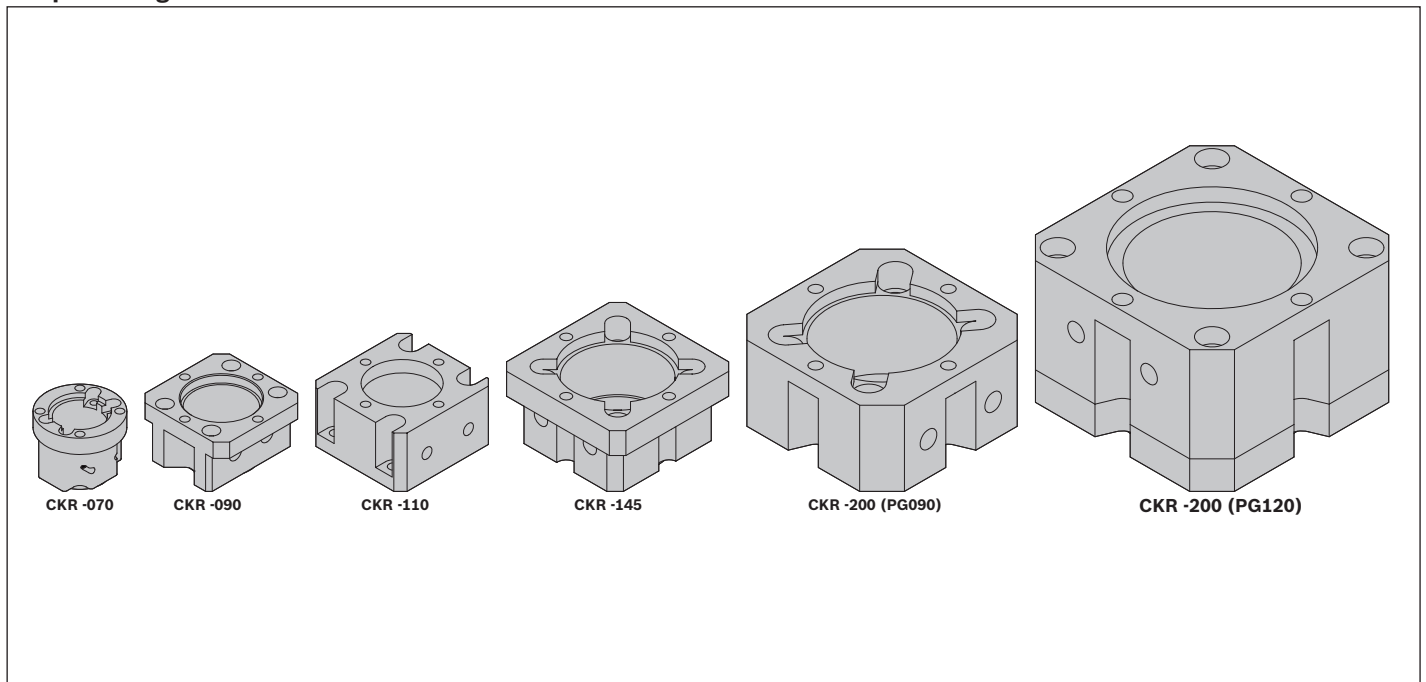

## Attachments and accessories

Mounting/mounting accessories

**Compact modules fit together perfectly – fast and flexible**

### Minimal mounting times, maximum efficiency

Standardized interfaces significantly reduce the effort during mounting.

The mechanical systems have positive-locking interfaces throughout.

They can be quickly and accurately connected together without time-consuming alignment.

### The result:

Users can respond flexibly to handling the different applications and tasks.

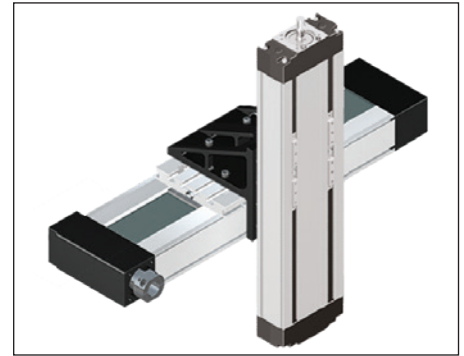

### Supplementary information for connection technology

See the catalog "Linear motion systems connection technology"

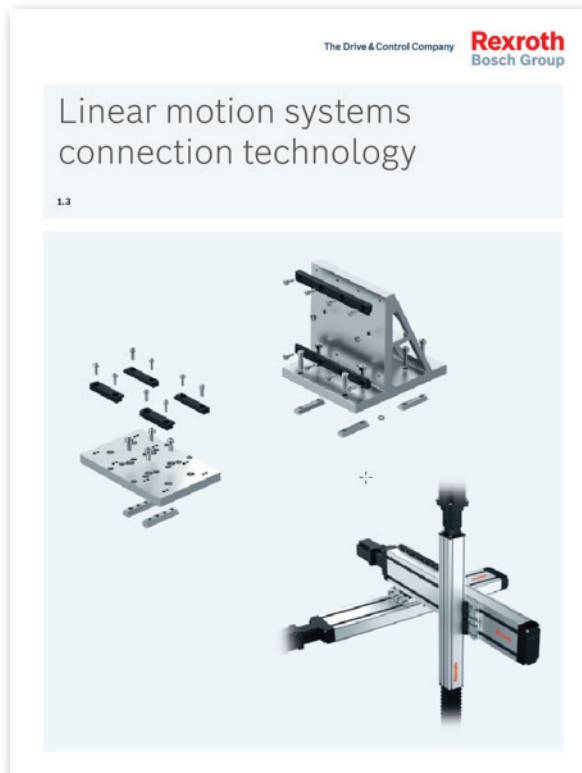

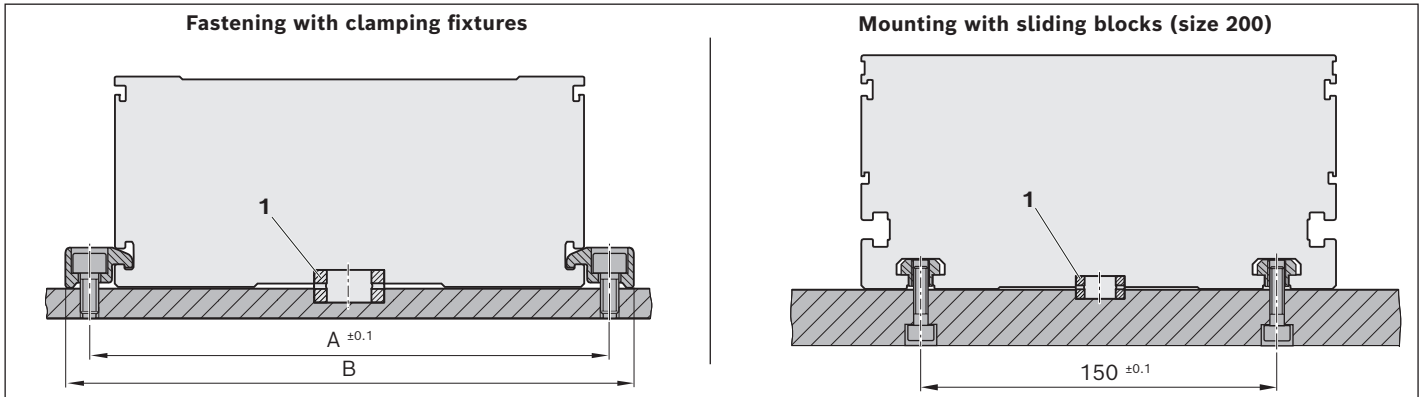

**1** For compact modules with centering holes in the ground area (selection via the guideway option):  
 Use centering rings to better align to other linear motion systems and connection elements.

**⚠ Do not fasten or support the compact module at the end enclosures! The frame is the load-bearing part!**

Size	Dimensions (mm)	
	A	B
-070	82	95
-090	102	112
-110	126	140
-145	161	175
-200	222	240

Mounting by means of special modification in the base surface of the frame is possible

**⚠ Option guideway 03 already includes threaded holes in the ground area of the frame (see dimension drawings).**

Size	Dimensions (mm)		
	A	B	C
-070	59	3	7.5
-090	76	4	7.5
-110	92	5	9.0
-145	124	6	13.0
-200	119	8	12.0

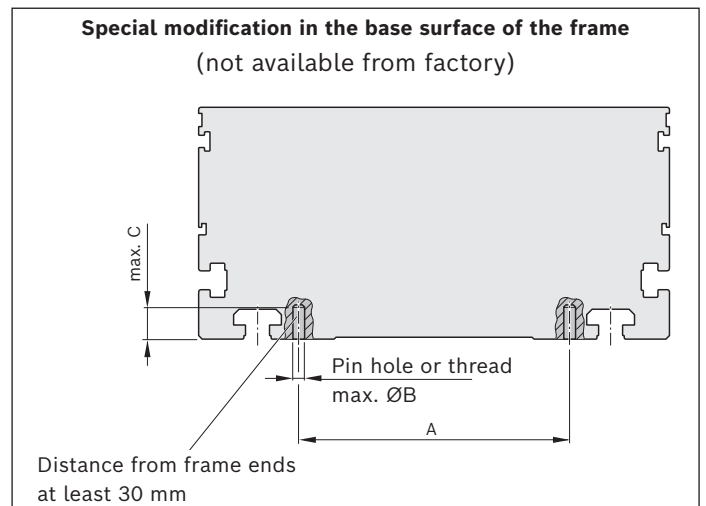

**Mounting accessories**

Recommended number of clamping fixtures:

- ▶ Type 1: 6/3<sup>1)</sup> pieces per meter and side
- ▶ Type 2: 4 pieces per meter and side
- ▶ Type 3: 3 pieces per meter and side
- ▶ Type 4: 3 pieces per meter and side

<sup>1)</sup> For size 070

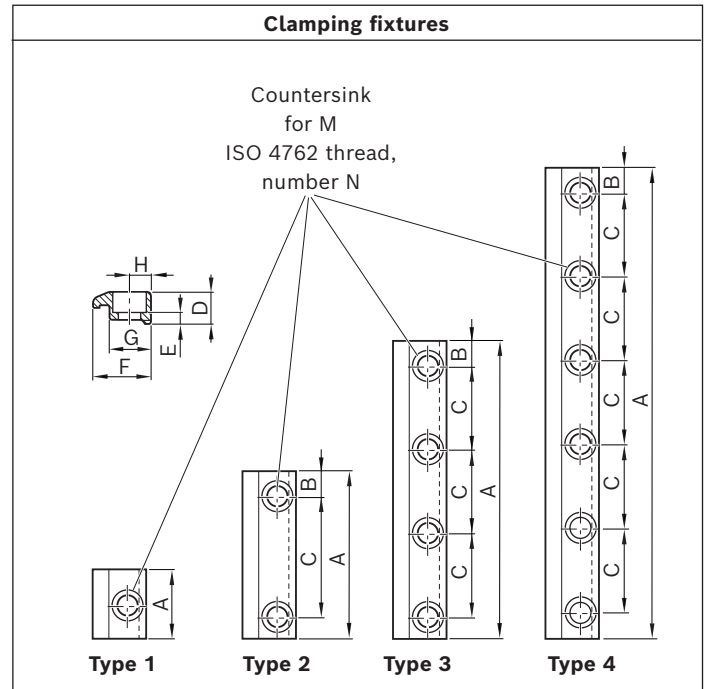

Size	For thread	Type	Number of bores N	Dimensions (mm)								Material number
				A	B	C	D	E	F	G	H	
<b>-070</b>	M5	1	1	22	-	-	10.0	4.8	15.0	12.2	6.5	R1419 010 01
		2	2	57	8.5	40	10.0	4.8	15.1	12.2	6.5	R1419 010 43
<b>-090</b>	M4	1	1	25	-	-	9.0	4.6	14.5	10.5	5.0	R0375 310 00
		3	4	87	6.0	25						R0375 310 02
		3	4	107	8.5	30						R0375 310 03
		2	2	72	11.0	50						R0375 310 32
		2	2	62	11.0	40						R0375 310 33
		3	4	87	13.5	20						R0375 310 38
		4	6	107	8.5	18						R0375 310 41
<b>-110 / -145</b>	M5	3	4	107	8.5	30	11.5	4.8	19.3	14.0	7.0	R0375 410 02
		3	4	77	8.5	20						R0375 410 26
		4	6	107	8.5	18						R0375 410 41
	M6	1	1	25	-	-	11.5	5.3	19.3	14.0	7.0	R0375 510 00
		3	4	142	11.0	40						R0375 510 02
		2	2	72	11.0	50						R0375 510 33
		2	2	62	11.0	40						R0375 510 34
		2	2	47	8.5	30						R0375 510 23
4	6	142	8.5	25	R0375 510 41							
<b>-200</b>	M8	2	2	108	19.0	70	27.5	16.3	29	19.0	9.0	R1175 290 26
		2	2	88	19.0	50		14.8				R1175 290 96
		2	2	78	19.0	40		14.8				R1175 290 97

Compact modules CKR: When mounting the clamping fixtures, observe a minimum distance of 10 mm to the end face of the frame.

**Sliding blocks, springs and strips**

Recommended number of sliding blocks:  
with 1 thread, 6 pieces per meter and side

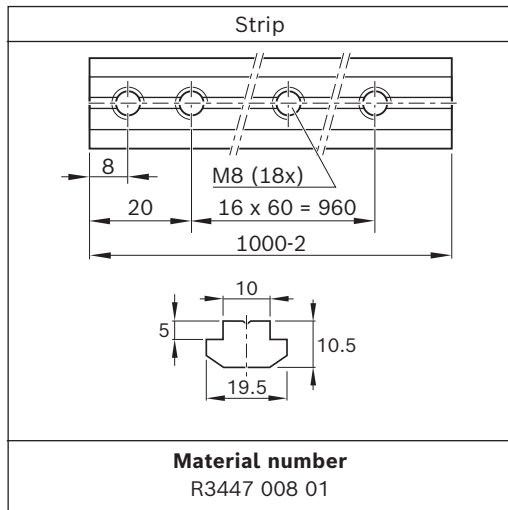

For fastening attachments on the connection plate.  
The spring serves as assembly and positioning aid.

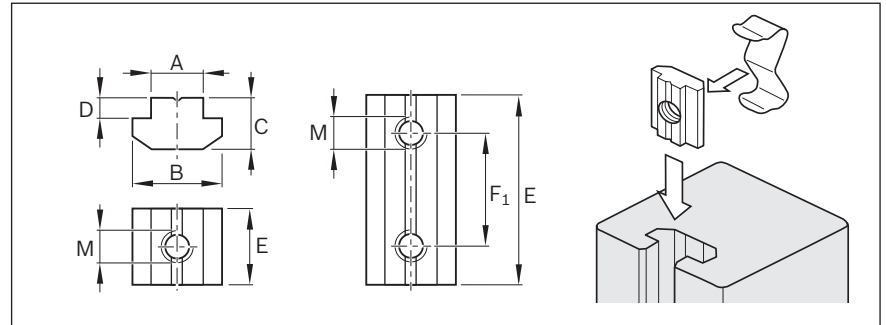

Size	For thread	Dimensions (mm)						Material number	
		A	B	C	D	E	F <sub>1</sub>	Sliding block	Spring
<b>-070</b>	M4	4	7.8	3.9	0.4	10	-	R0375 210 20	-
	M4					19	10	R0375 210 21	-
<b>-090 / -110</b>	M4	6	11.5	4.0	1.0	12	-	R3447 014 01	R3412 010 02
	M5					45	30	R0391 710 09	-
	M5					12	-	R3447 015 01	R3412 010 02
	M4					16	-	R3447 017 01	R3412 011 02
<b>-145</b>	M5	8	16.0	6.0	2.0	16	-	R3447 018 01	R3412 011 02
	M6					16	-	R3447 019 01	R3412 011 02
	M6					50	36	R0391 710 08	-
	M8					16	-	R3447 020 01	R3412 011 02
	M4					20	-	R3447 012 01	R3412 009 02
	M5					20	-	R3447 011 01	R3412 009 02
<b>-200</b>	M6	10	19,5	10,5	5,0	20	-	R3447 010 01	R3412 009 02
	M8					20	-	R3447 009 01	R3412 009 02
	M8					90	70	R0391 710 07	-

**Centering rings**

The centering ring serves as a positioning aid and for positive locking when mounting customer-built attachments to the carriage and the frame.

It creates a positive-locking connection with good reproducibility.

Material: Steel

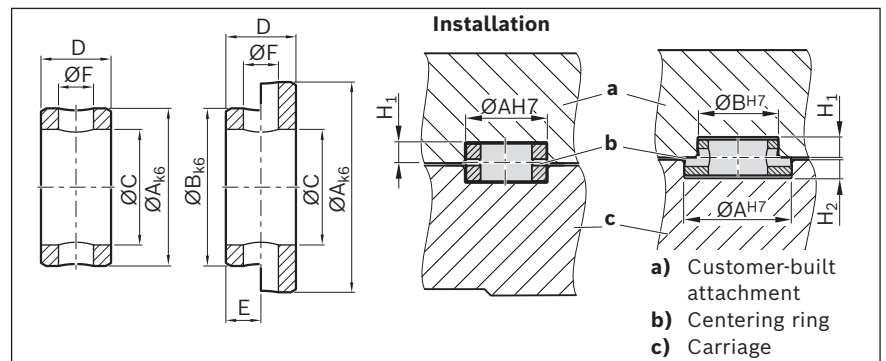
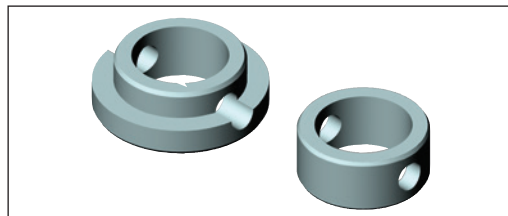

Ø Size (mm)	Dimensions (mm)						Material number		
	A	B	C ±0.1	D -0.2	E +0.2	ØF	H <sub>1</sub> +0.2	H <sub>2</sub> +0.2	
<b>5</b>	5	-	3.4	3.0	-	1.6	1.6	-	R0396 605 42
<b>7</b>	7	-	5.5	3.0	-	1.6	1.6	-	R0396 605 43
<b>9</b>	9	-	6.6	4.0	-	2.0	2.1	-	R0396 605 44
<b>12</b>	12	-	9.0	4.0	-	2.0	2.1	-	R0396 605 45
<b>16</b>	16	-	11.0	6.0	-	3.0	3.1	-	R0396 605 46
<b>7 - 5</b>	7	5	3.4	3.0	1.5	1.6	1.6	1.6	R0396 605 47
<b>9 - 5</b>	9	5	3.4	3.5	1.5	1.6	2.1	1.6	R0396 605 48
<b>9 - 7</b>	9	7	5.5	3.5	1.5	1.6	2.1	1.6	R0396 605 49
<b>12 - 9</b>	12	9	6.6	4.0	2.0	2.0	2.1	2.1	R0396 605 50
<b>16 - 12</b>	16	12	9.0	5.0	2.0	2.0	2.1	3.1	R0396 605 51

Connection plates

**CKK/CKR -070**

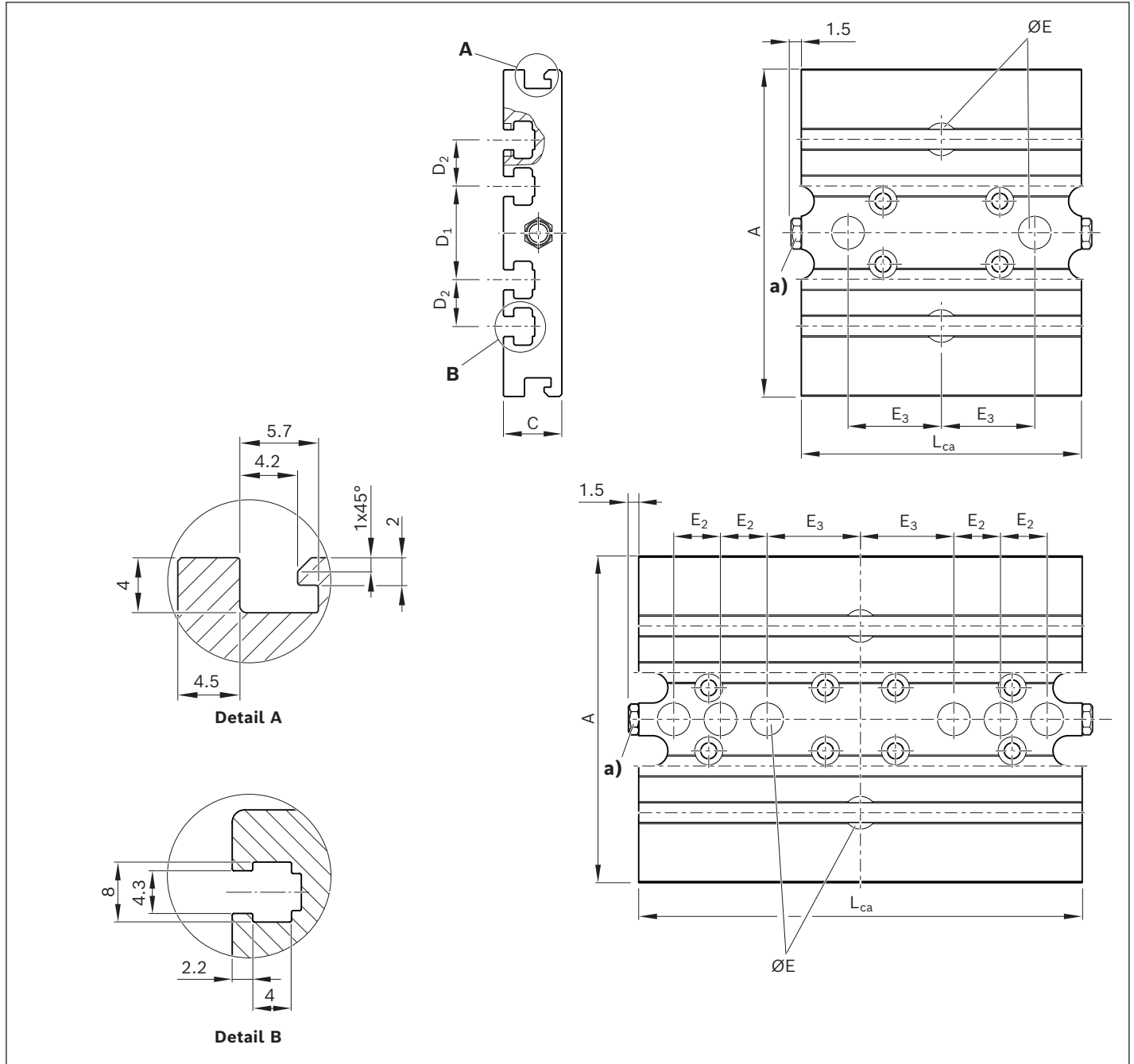

**a)** Funnel-type lube nipple DIN 3405-D4; lubrication points from two sides (central lubrication only necessary with grease gun on one of the two sides).

The connection plates differ in appearance in the representation. Shown here is the connection plate for CKR-070.



**Function:**

- ▶ Fastening of attachments (with sliding blocks)
- ▶ Lubrication of the ball rail system and the ball screw assembly possible via the connection plate
- ▶ For lube version LSS, LPG

**The assembly consists of:**

- ▶ Connection plate
- ▶ Mounting accessories for fastening to the carriages
- ▶ Sliding blocks are not included with delivery

CKK/CKR	Dimensions (mm)									
	CKK	L <sub>ca</sub> CKR	A	C	D <sub>1</sub>	D <sub>2</sub>	ØE <sup>H7</sup>	E <sub>2</sub> ±0.01	E <sub>3</sub> ±0.01	
-070	60	60	70	12.5	20	10	7 - 1.6 <sup>+0.2</sup> deep	10	20	
	95	95								

CKK/CKR	L <sub>ca</sub> (mm)	Material number		Mass (kg)
		CKK	CKR	
-070	60	R0375 200 15	R0375 200 16	0.11
	95	R0375 200 10	R0375 200 11	0.17

**CKK and CKR -090, -110, -145, -200**

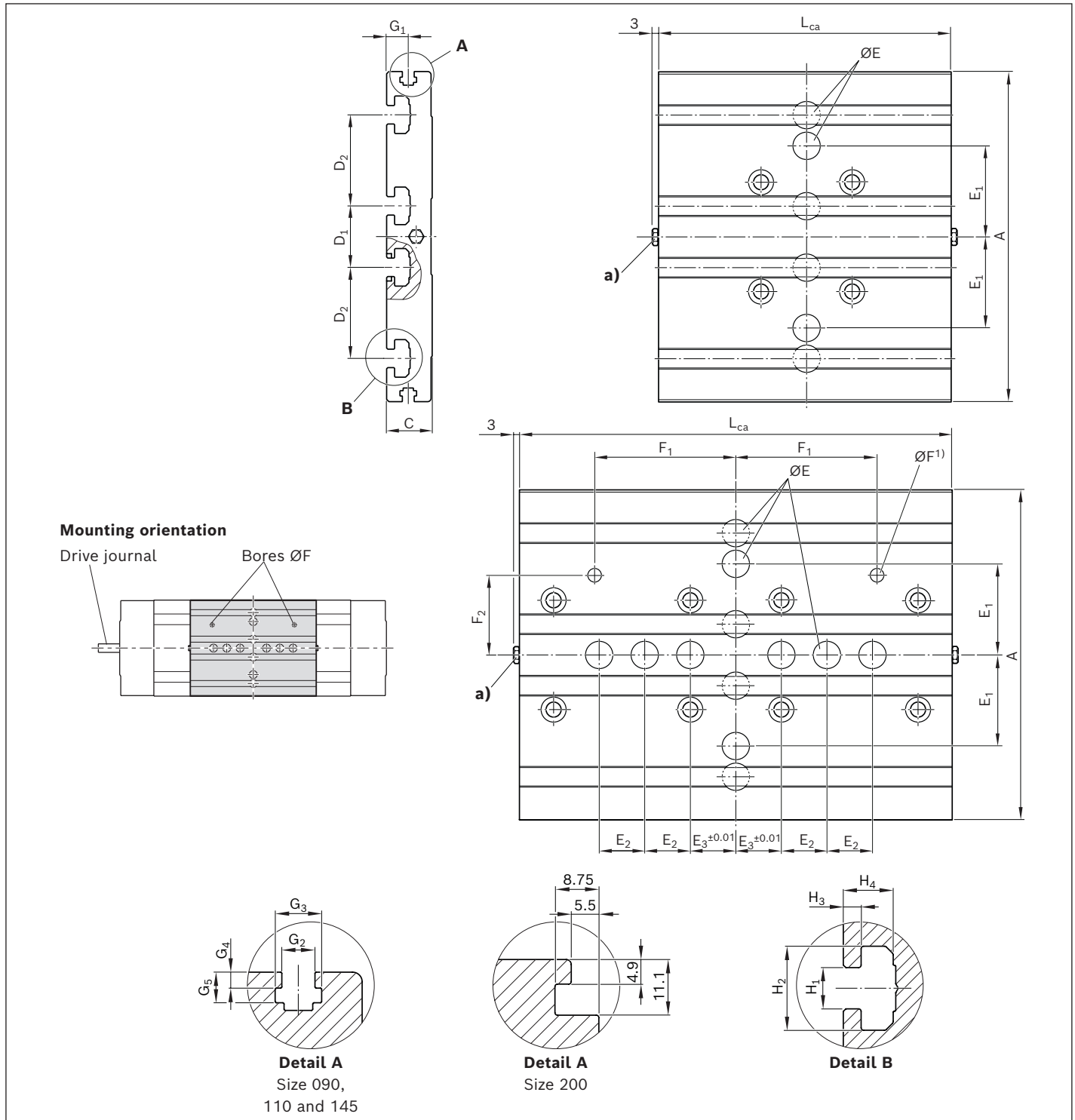

1) For customer-built attachment

**a)** Funnel-type lube nipple AM8 x 1 for lube version LSS/LPG; lubrication points from two sides (central lubrication only necessary with grease gun on one of the two sides).

Lube fittings for lube versions LCF/LCO see next page.

The connection plates differ in appearance in the representation. Shown here is the connection plate for CKK-145.

**Function:**

- ▶ Fastening of attachments (with sliding blocks)
- ▶ Lubrication of the ball rail system and the ball screw assembly possible via the connection plate
- ▶ For lube version LSS, LPG

**The assembly consists of:**

- ▶ Connection plate
- ▶ Mounting accessories for fastening to the carriages
- ▶ Sliding blocks are not included with delivery

CKK/ CKR	Dimensions (mm)																							
	CKK	CKR	L <sub>ca</sub>	A	C	D <sub>1</sub>	D <sub>2</sub>	ØE <sup>H7</sup>	E <sub>1</sub>	E <sub>2</sub>	E <sub>3</sub>	ØF <sup>H7</sup>	F <sub>1</sub>	F <sub>2</sub>	G <sub>1</sub>	G <sub>2</sub>	G <sub>3</sub>	G <sub>4</sub>	G <sub>5</sub>	H <sub>1</sub>	H <sub>2</sub>	H <sub>3</sub>	H <sub>4</sub>	
-090		60		90	16	20	20	9 - 2.1 deep	-	-														
		125								10			4 - 6 deep	38.0	20	7.6	4.2	7.3	2.0	4.3	6	12.0	3.5	7.7
-110	60	110		110	16	20	20	9 - 2.1 deep	-	-														
		155								10			5 - 6.5 deep	46.0	42	9.5	5.2	7.3	2.5	4.8	6	12.0	3.5	7.7
-145	80	125		145	20	27	40	12 - 2.1 deep	40	-														
		190								20			6 - 12 deep	62.0	35	9.5	5.2	7.3	2.5	4.8	8	16.5	3.5	9.8
-200		190		200	27	40	40	16 - 3.1 deep	-	-														
		305								20			8 - 16 deep	59.5	41	-	-	-	-	-	10	20.1	6.0	12.5

CKK/CKR	L <sub>ca</sub> (mm)		Material number		Mass (kg)	
	CKK	CKR	CKK	CKR	CKK	CKR
-090		60	R0375 300 15	R0375 300 16		0.18
		125	R0375 300 10	R0375 300 11		0.37
-110	60	110	R0375 400 15	R0375 400 16	0.23	0.38
		155	R0375 400 10	R0375 400 11	0.59	0.58
-145	80	125	R0375 500 15	R0375 500 16	0.50	0.81
		190	R0375 500 10	R0375 500 11	1.20	1.15
-200		190	R0375 600 15	R0375 600 16	2.20	2.20
		305	R0375 600 10	R0375 600 11	3.60	3.60

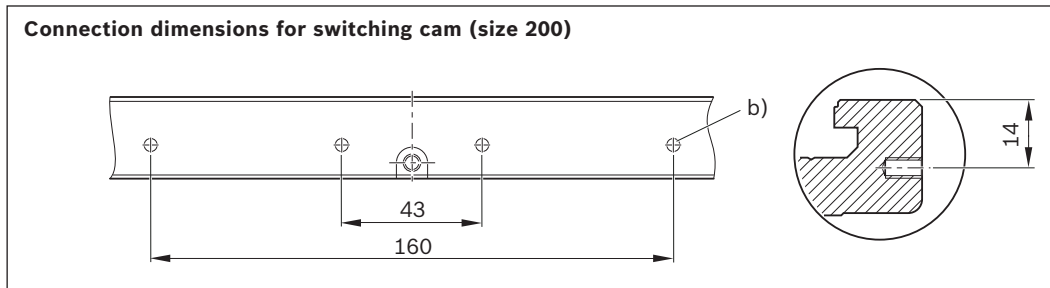

b) M4 - 6 deep

For lube version LCF/LCO

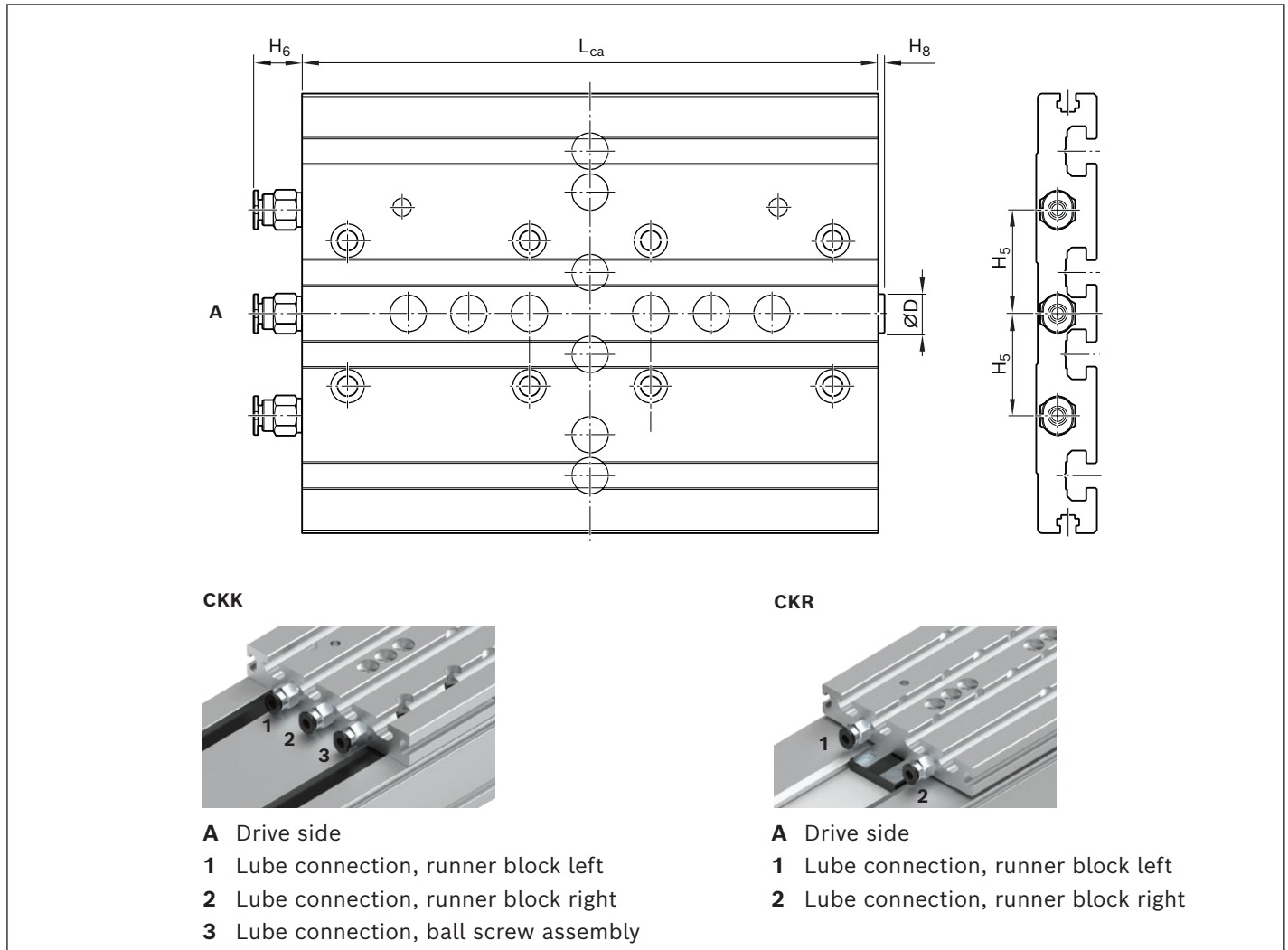

CKK/CKR	Dimensions (mm)					
	ØD	CKK	H <sub>5</sub> CKR	H <sub>6</sub>	H <sub>8</sub>	L <sub>ca</sub>
-070	-	-	-	-	-	-
-090	8.5	19	19	12.5	3	125
-110	8.5	20	40		3	155
-145	-	26	42		-	190
-200	-	31	55		-	305

More dimensions ➔ Chapter "Connection plates".

Lube fittings: Straight connector (SW 9), for Ø 4 mm plastic tubes and metal pipes

Cover

Resist

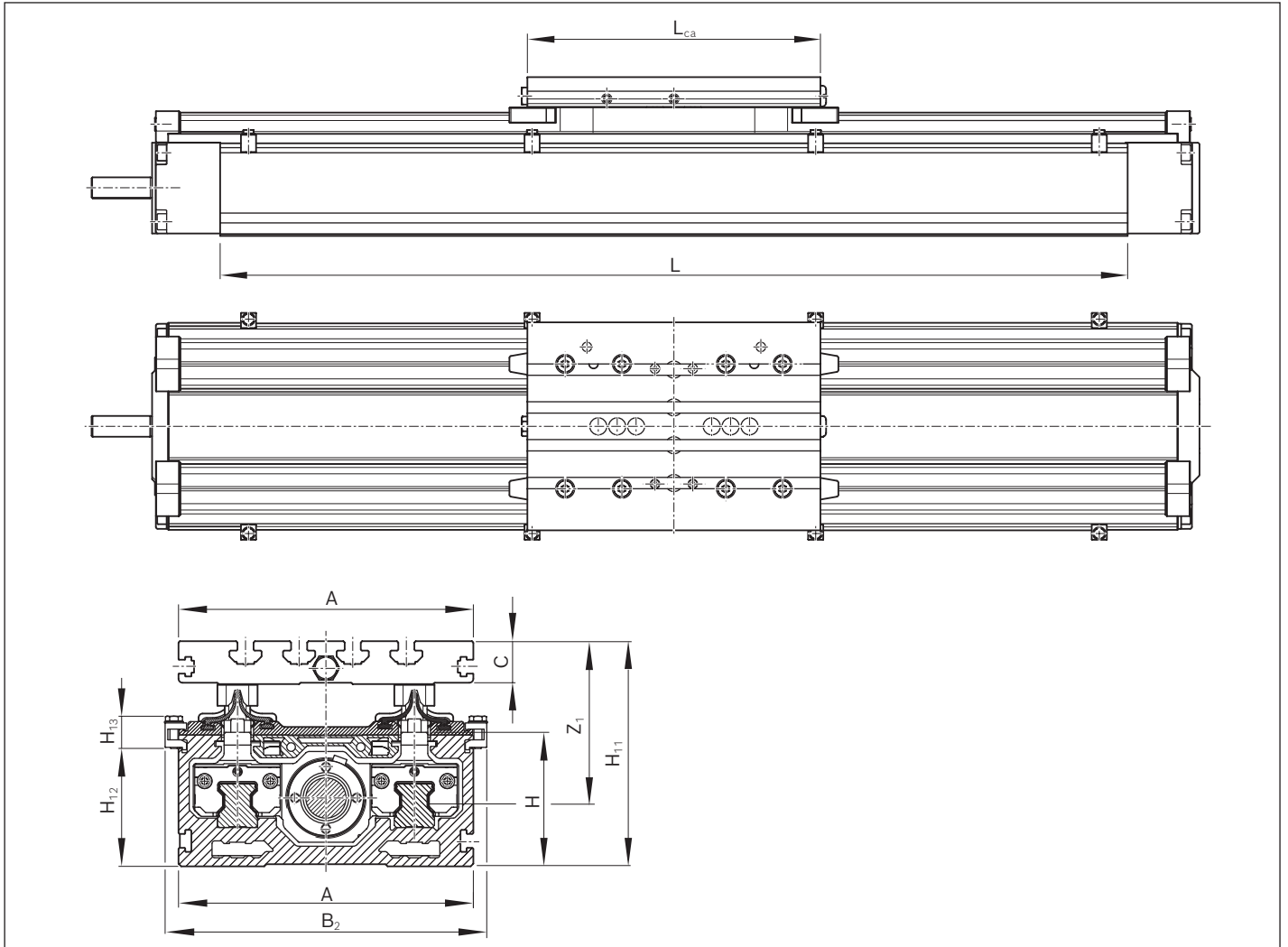

CKK	Dimensions (mm)									
	A	B <sub>2</sub>	C	H	H <sub>11</sub>	H <sub>12</sub>	H <sub>13</sub>	L <sub>ca</sub>	Z <sub>1</sub>	
-110	100	120	16	50	84	44	12	155	60.7	
-145	145	155	20	65	105	59	12	190	71.6	
-200	200	212	27	100	150	82	24	305	86.4	

Z<sub>1</sub> = Application point of the effective force

## Connecting shafts

### Features

- ▶ Bridge large distances between axes
- ▶ Can be mounted radially by split clamping hub
- ▶ Mounting and dismounting without shifting the aligned axes
- ▶ Backlash-free and torsionally stiff

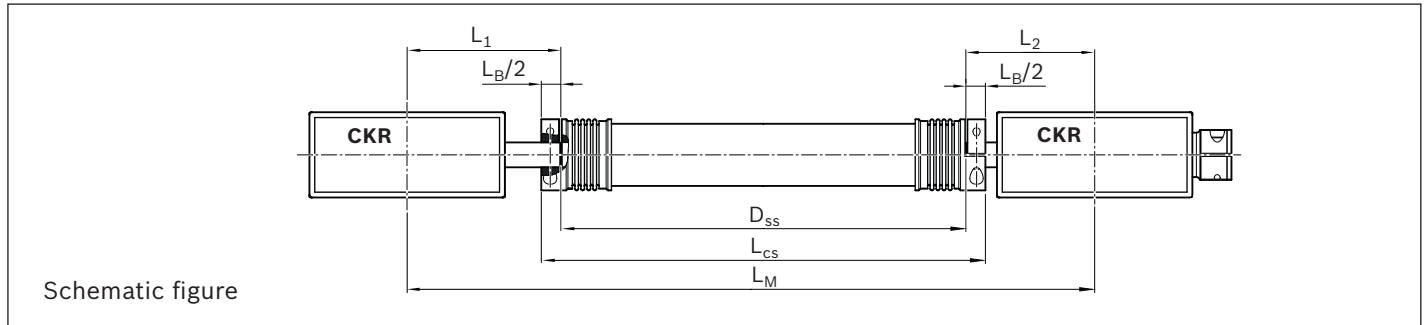

### CKR-070

#### Material

Coupling hub: high-strength aluminum

Elastomer circle: precision manufactured, extremely wear resistant, and thermally stable plastic

Connecting tube: high-precision aluminum tube

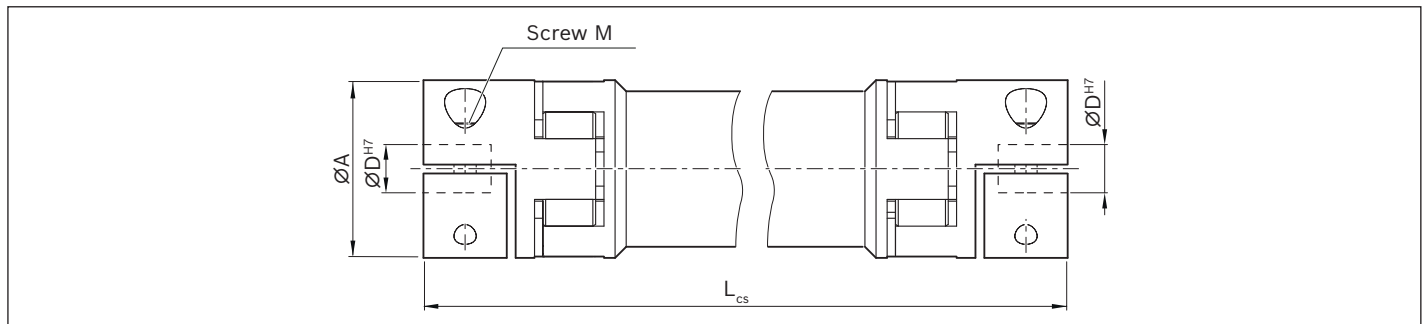

### CKR-090, -110, -145, -200

#### Material

Bellows: highly flexible stainless steel

Connecting tube and clamping hub: Aluminum

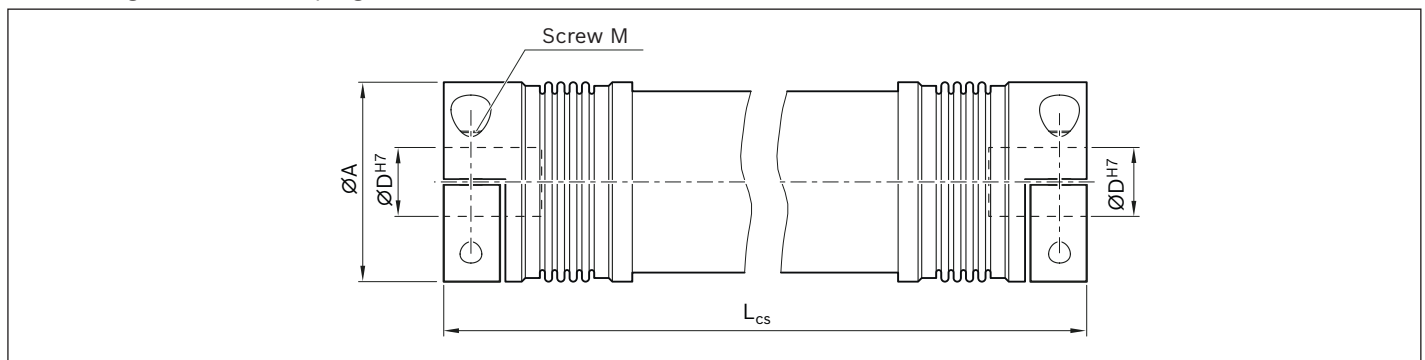

Size	Material number	Dimensions (mm)							M <sub>A</sub> (Nm)
		A	D	M	L <sub>B</sub>	L <sub>CS min</sub>	L <sub>CS max</sub>		
-070	R0391 510 22	30	8	M4	21	95	2,400	4	
-090	R0391 510 16	40	10	M4	22	105	3,000	5	
-110	R0391 510 20	40	14	M4	22	105	3,000	5	
-145	R0391 510 18	55	19	M6	32	150	3,000	15	
-200	R0391 510 19	83	24	M10	50	200	3,000	70	

Size	M <sub>S</sub> (Nm)	M <sub>CS</sub> (Nm)	Mass moment of inertia (10 <sup>-6</sup> kgm <sup>2</sup> )	Weight (kg)
-070	25	12.5	0.090 · (L <sub>CS</sub> (mm) - 80) + 30	0.00054 · (L <sub>CS</sub> (mm) - 80) + 0.12
-090	17	10.0	0.032 · (L <sub>CS</sub> (mm) - 80) + 68.2	0.00090 · (L <sub>CS</sub> (mm) - 80) + 0.21
-110	17	10.0	0.032 · (L <sub>CS</sub> (mm) - 80) + 68.2	0.00090 · (L <sub>CS</sub> (mm) - 80) + 0.21
-145	45	30.0	0.670 · (L <sub>CS</sub> (mm) - 118) + 246	0.00120 · (L <sub>CS</sub> (mm) - 118) + 0.62
-200	170	170.0	4.500 · (L <sub>CS</sub> (mm) - 160) + 2,000	0.00320 · (L <sub>CS</sub> (mm) - 160) + 2.00

**Bending-critical speed**

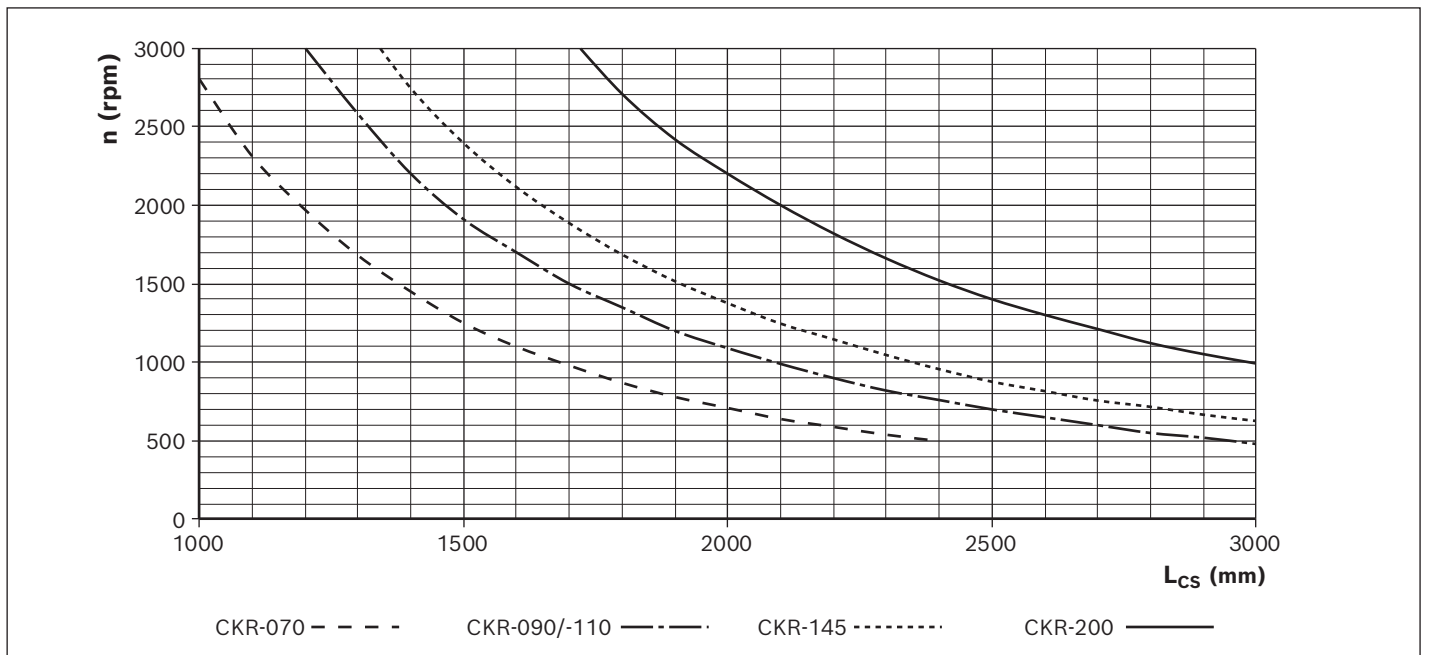

**Order**

Please state the material number and length L<sub>CS</sub>.  
e.g.: R0391 510 20, L<sub>CS</sub> = 550 mm

$$L_{CS} = D_{SS} + L_B$$

$$D_{SS} = L_M - L_1 - L_2$$

L<sub>1</sub>/L<sub>2</sub>: For the calculation, refer to the dimension drawings

- D<sub>SS</sub> = Distance drive journals
- L<sub>CS</sub> = Overall length of the connecting shaft
- L<sub>M</sub> = Centerline-to-centerline distance between compact modules
- M<sub>A</sub> = Tightening torque of screws
- M<sub>CS</sub> = Rated torque of connecting shaft
- M<sub>S</sub> = Peak torque of connecting shaft
- n = Rotary speed (rpm)
- L<sub>CS</sub> = Overall length of the connecting shaft (mm)

**Combination possibilities for multi-axis systems with connecting shaft**

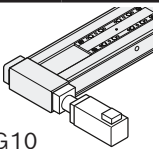
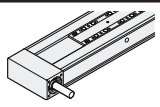
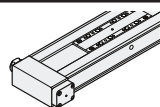
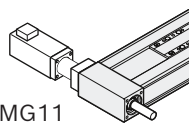
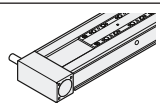
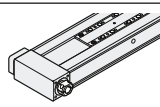
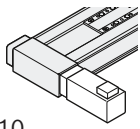
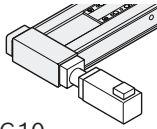
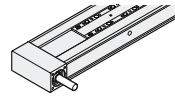
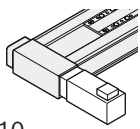
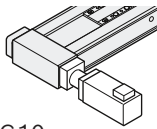
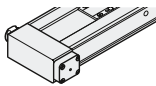
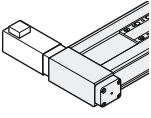
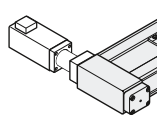
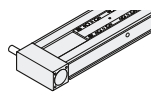
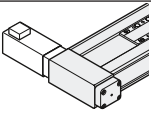
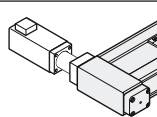
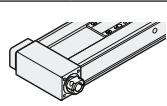
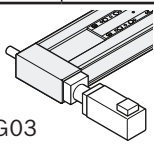
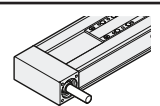
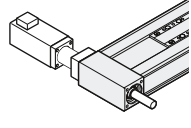
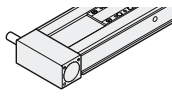
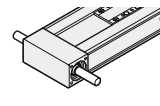
Size	Version				
-070	 MG10		↔	 MA01	 MA06
	 MG11			 MA02	 MA05
-090 -110 -145	 MA10	 MG10	↔	 MA01	
	 MA10	 MG10		↔	 MA06
	 MA11	 MG11	↔		 MA02
	 MA11	 MG11		↔	 MA05
-200	 MG03		↔		 MA01
	 MG04			 MA02	 MA03

**Drive end enclosure with additional drive journal**

In the versions MA05, MA06, MA10, MA11, MG10 and MG11, a second drive journal can be made available by removing the screws and cover.

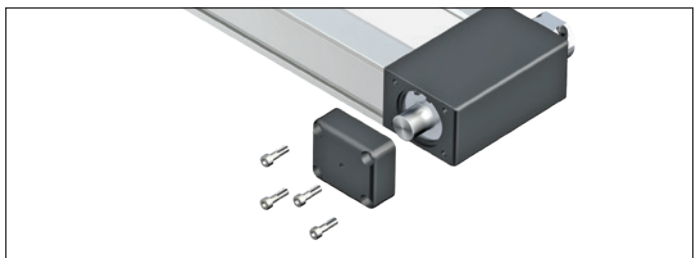



**Cover**

By attaching the cover, the open end of the drive (clamping hub) is closed.  
This means there is no longer any risk of injury from the rotating motor holder.

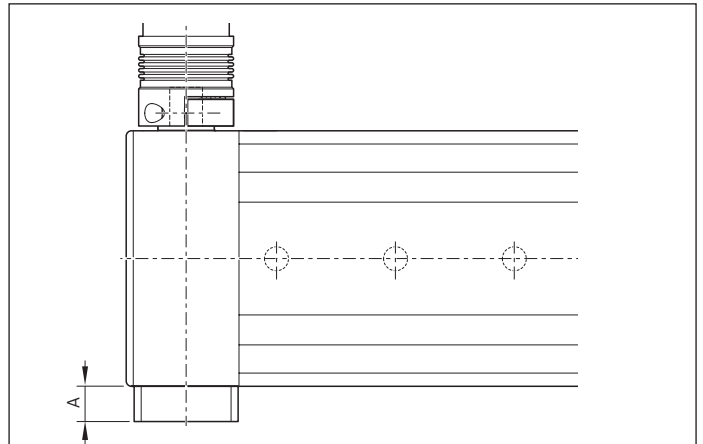
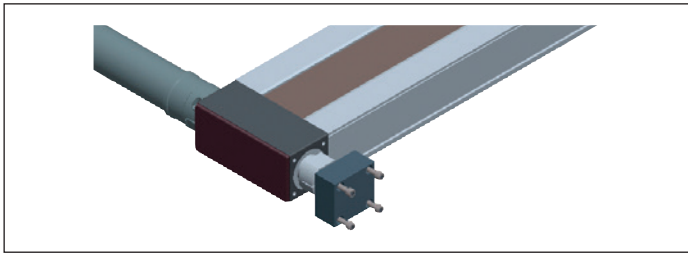

Size	Dimension (mm)	Material number
	<b>A</b>	
-070	20	R0375 200 09
-090	24	R0375 300 09
-110	26	R0375 400 09
-145	31	R0375 500 09

**Nozzle pipe**

For manual grease guns. For the lubrication of funnel-type and ball-type lube nipples.

Scope of delivery:

Nozzle pipe, interchangeable insert A for funnel-type lube nipple, interchangeable insert B for ball-type lube nipple.

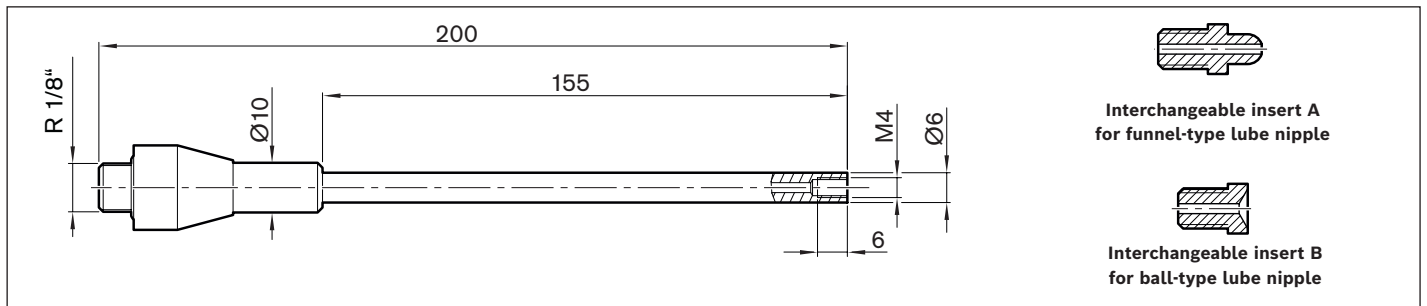

Material number	Mass (g)
R345503106	158

**Frequency meter**

For checking the toothed belt pretension on linear axes with a toothed belt drive, as well as for setting the toothed belt pretension with a drive over the belt side drive.

Motors

**Motor attachment kits according to customer specification**

The motor of linear motion systems with ball screw assembly is attached by either an attachment kit with flange and coupling (MF) or a belt side drive (RV).

The available combinations are shown in the "Configuration and ordering" selection tables for each size. In addition to attachment kits for Rexroth motors, attachment kits for motors according to customer specification are also available. In order to determine the appropriate attachment kit, the connection geometry of the motor is crucial. Characteristics required to clearly determine motor geometry are shown below.

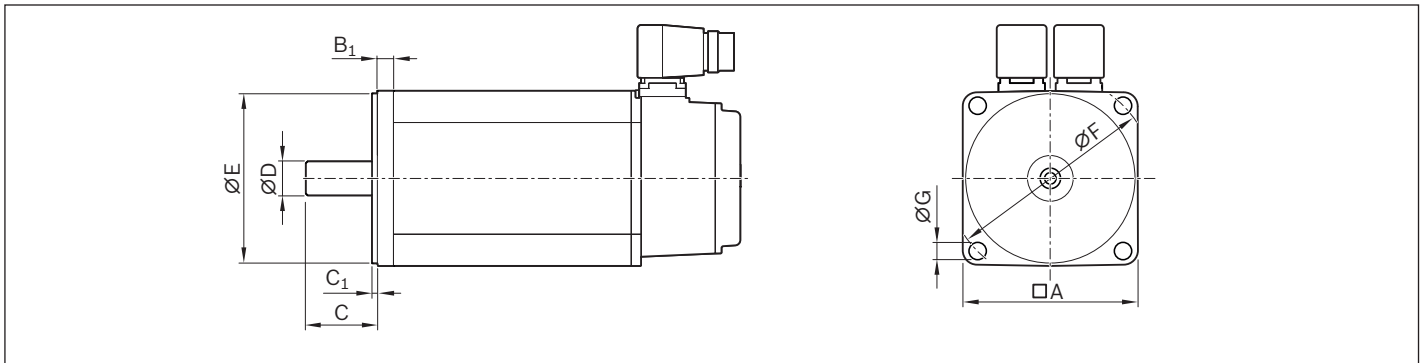

The dimensions queried result in a unique "motor geometry code":

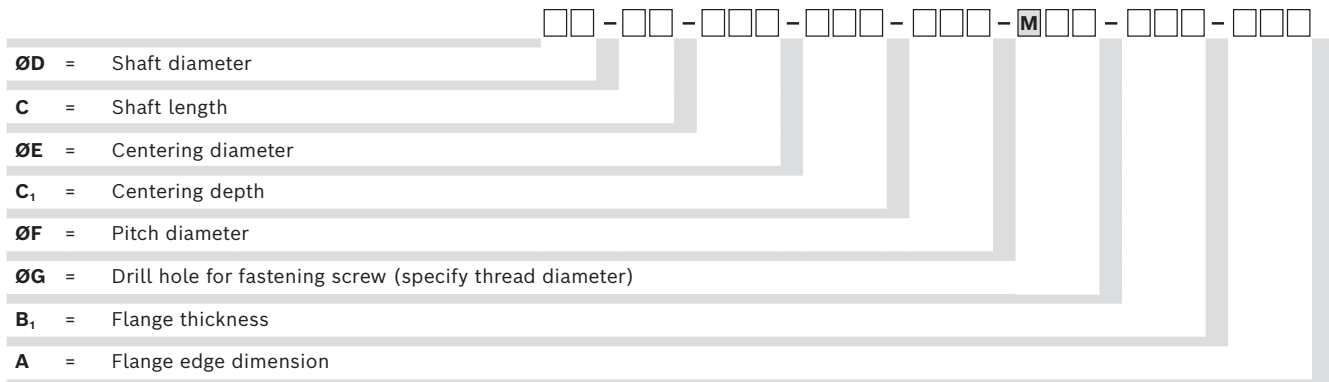

**Example illustration of servo motor IndraDyn S type MS2N04**

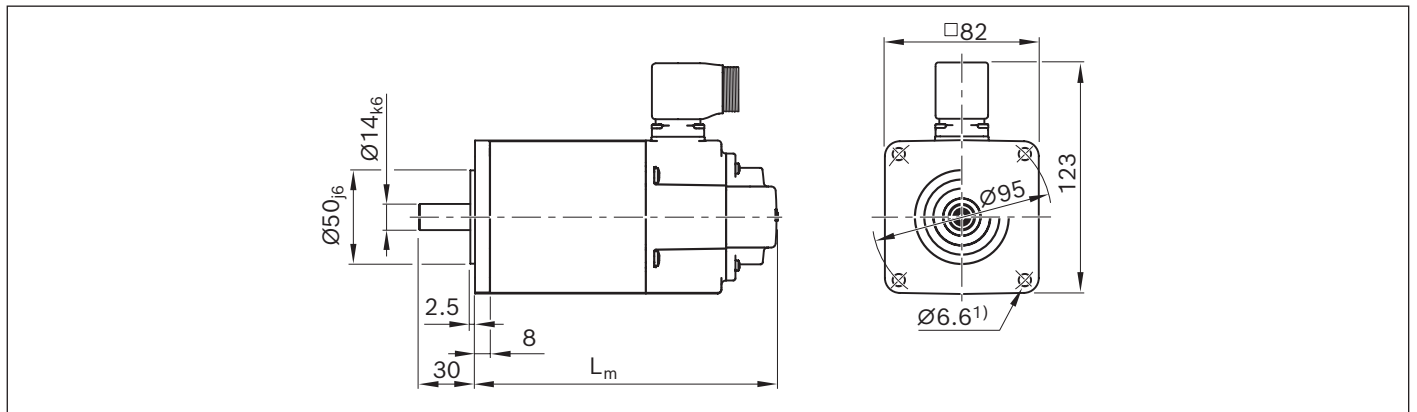

**1 4 - 3 0 - 0 5 0 - 2 . 5 - 0 9 5 - M 0 6 - 0 0 8 - 0 8 2**

<sup>1)</sup> The drill hole  $\text{Ø} 6.6$  mm results in the type designation M06 for the geometry motor code (nominal thread diameter fastening screw M6).

Motor attachment kits for motors according to customer specification can be configured using the online configurator in the eShop. To do this, select the "Attachment kits for motors according to customer specification" option.

Enter motor geometry in the input dialog box. The dimensions can be entered directly or by using a drop-down menu.

**Size of customer motor**

Motor manufacturer  ▼

Motor type  ▼

Side view diagram of a motor with dimensions: B1: ??? mm, Ø E: ??? mm, Ø D: ??? mm, C1: ??? mm, C: ??? mm.

Top view diagram of a motor with dimensions: A: ??? mm, Ø F: ??? mm, Ø G: ??? mm.

---

**Example**

Size of customer motor

Motor manufacturer  ▼

Motor type  ▼

Side view diagram of a motor with dimensions: B1: 10 mm, Ø E: 110 mm, Ø D: 24 mm, C1: 3.5 mm, C: 50 mm.

Top view diagram of a motor with dimensions: A: 126 mm, Ø F: 130 mm, Ø G: (blank).

**IndraDyn S - Servo motors MSM**

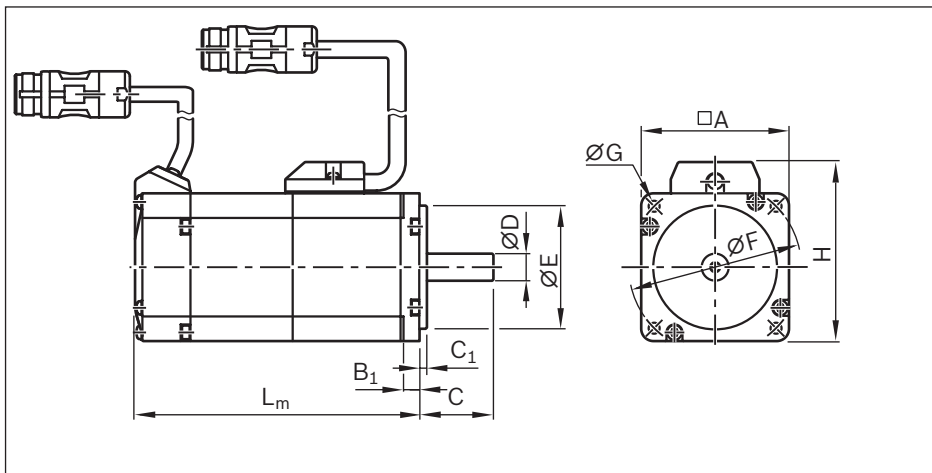

Motor schematic

Motor code	Dimensions (mm)										
	A	B <sub>1</sub>	C	C <sub>1</sub>	Ø D h6	Ø E h7	Ø F	Ø G	H	L <sub>m</sub>	
										Brake without	with
MSM 019A-0300	38	6.0	25	3	8	30	45	3.4	51	72.0	102.0
MSM 019B-0300	38	6.0	25	3	8	30	45	3.4	51	92.0	122.0
MSM 031B-0300	60	6.5	30	3	11	50	70	4.5	73	79.0	115.5
MSM 031C-0300	60	6.5	30	3	14	50	70	4.5	73	98.5	135.0
MSM 041B-0300	80	8.0	35	3	19	70	90	6.0	93	112.0	149.0

**Version:**

- ▶ Plain shaft without shaft seal
- ▶ M5 multi-turn absolute encoder (20-bit, absolute encoder function only available with backup battery)
- ▶ Cooling system: natural convection
- ▶ IP54 protection class (shaft IP40)
- ▶ With or without holding brake
- ▶ M17 metal round connector

**Note**

Motors are available with controllers and control systems. For more information on motors, controllers and control systems, please refer to the Rexroth automation solutions ➡ Chapter "Further information"

Motor data									Motor connection 1/2 cable(s)	Holding brake	Type code	Material number
$n_{max}$ (rpm)	$M_0$ (Nm)	$M_{max}$ (Nm)	$M_{br}$ (Nm)	$J_m$ (kgm <sup>2</sup> )	$J_{br}$ (kgm <sup>2</sup> )	$m_m$ (kg)	$m_{br}$ (kg)					
5,000	0.16	0.48	0.29	0.0000025	0.0000002	0.32	0.21	2	N	MSM 019A-0300-NN-M5-MH0	R911344209	
									Y	MSM 019A-0300-NN-M5-MH1	R911344210	
5,000	0.32	0.95	0.29	0.0000051	0.0000002	0.47	0.21	2	N	MSM 019B-0300-NN-M5-MH0	R911344211	
									Y	MSM 019B-0300-NN-M5-MH1	R911344212	
5,000	0.64	1.91	1.27	0.0000140	0.0000018	0.82	0.48	2	N	MSM 031B-0300-NN-M5-MH0	R911344213	
									Y	MSM 031B-0300-NN-M5-MH1	R911344214	
5,000	1.30	3.80	1.27	0.0000260	0.0000018	1.20	0.50	2	N	MSM 031C-0300-NN-M5-MH0	R911344215	
									Y	MSM 031C-0300-NN-M5-MH1	R911344216	
4 500	2.40	7.10	2.45	0.0000870	0.0000075	2.30	0.80	2	N	MSM 041B-0300-NN-M5-MH0	R911344217	
									Y	MSM 041B-0300-NN-M5-MH1	R911344218	

**Motor characteristic**  
(Schematic)

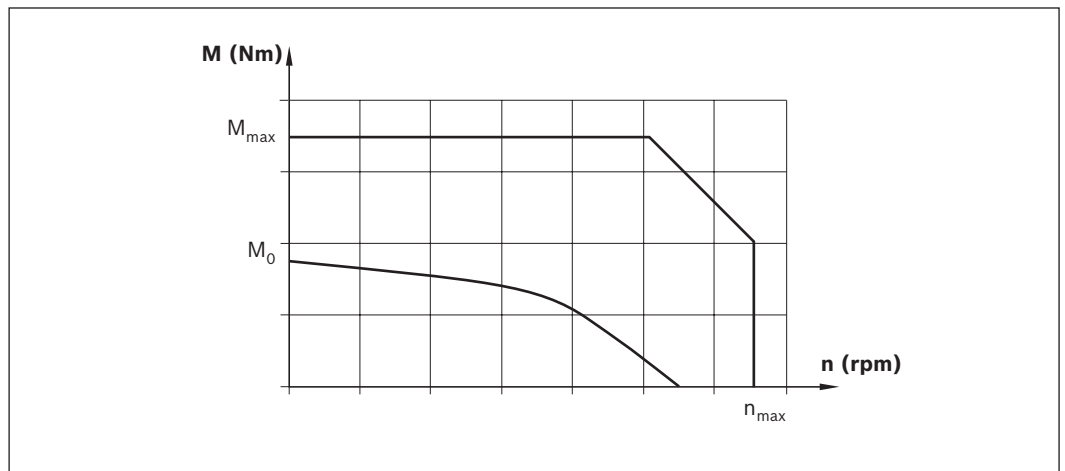

**IndraDyn S - Servo motors MS2N**

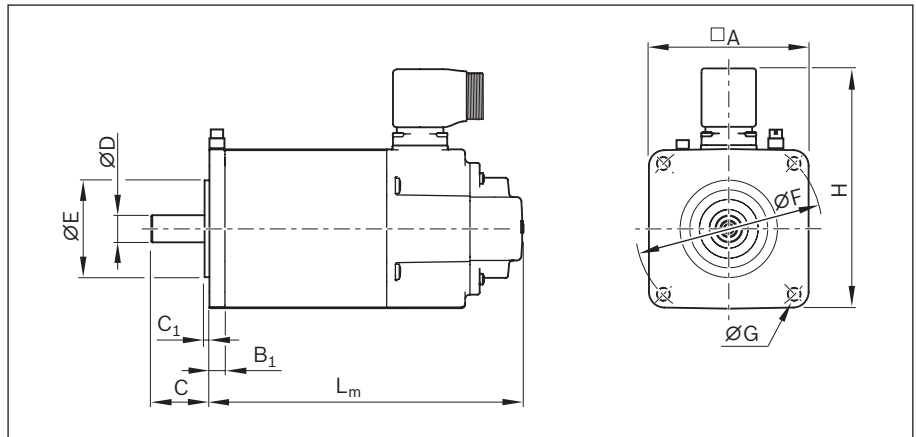

Motor schematic

**Dimensions / motor data**

Motor code	Dimensions (mm)											
	□ A	B <sub>1</sub>	C	C <sub>1</sub>	Ø D <sub>k6</sub>	Ø E <sub>J7</sub>	Ø F	Ø G	H		L <sub>m</sub>	
									Cable	without	with	with
MS2N03-B0BYN	58	7.5	20	2.5	9	40	63	4.5	2	1	163	192
MS2N03-D0BYN	58	7.5	23	2.5	11	40	63	4.5	2	1	203	232
MS2N04-B0BTN	82	8	30	2.5	14	50	95	6.6	2	1	162	194.5
MS2N04-C0BTN	82	8	30	2.5	14	50	95	6.6	2	1	194	226.5
MS2N04-D0BQN	82	8	30	2.5	14	50	95	6.6	2	1	226	258.5
MS2N05-B0BTN	98	9	40	3	19	95	115	9	2	1	188	218
MS2N05-C0BTN	98	9	40	3	19	95	115	9	2	1	224	254
MS2N05-D0BRN	98	9	40	3	19	95	115	9	2	1	260	290
MS2N06-B1BNN	116	14	50	3	24	95	130	9	2	1	164	201
MS2N06-C0BTN	116	14	50	3	24	95	130	9	2	1	184	202
MS2N06-D0BRN	116	14	50	3	24	95	130	9	2	1	224	261
MS2N06-D1BNN	116	14	50	3	24	95	130	9	2	1	224	261
MS2N06-E0BRN	116	14	50	3	24	95	130	9	2	1	264	301
MS2N07-B1BNN	140	18	58	4	32	130	165	11	2	1	176	230
MS2N07-C0BQN	140	18	58	4	32	130	165	11	2	1	205	259
MS2N07-C1BRN	140	18	58	4	32	130	165	11	2	1	205	259
MS2N07-D1BNN	140	18	58	4	32	130	165	11	2	1	263	317

**Version**

- ▶ Plain shaft without shaft seal ring
- ▶ Multi-turn encoder
- ▶ Advanced encoder (B) in conjunction with 1-cable connector (AcuroLink interface)
- ▶ IP64 protection class
- ▶ With or without holding brake
- ▶ Special ground connection terminal near motor flange (used as needed)

**Note**

Motors are available with controllers and control systems. For more information on motors, controllers and control systems, please refer to the Rexroth automation solutions ➡ Chapter "Further information". For further information on the type code, see chapter "Type code".

Motor data									Motor connection	Brake	Type code	Material number
$n_{max}$ (rpm)	$M_0$ (Nm)	$M_{max}$ (Nm)	$M_{br}$ (Nm)	$J_m$ (kgm <sup>2</sup> )	$J_{br}$ (kgm <sup>2</sup> )	$m_m$ (kg)	$m_{br}$ (kg)					
9,000	0.73	3.46	1.8	0.000023	0.000007	1.4	0.4	1	N	MS2N03-B0BYN-CMSH0-NNNNE-NN	R911384767	
								1	Y	MS2N03-B0BYN-CMSH1-NNNNE-NN	R911384769	
9,000	1.15	6.8	1.8	0.000037	0.000007	2.0	0.4	1	N	MS2N03-D0BYN-CMSH0-NNNNE-NN	R911384772	
								1	Y	MS2N03-D0BYN-CMSH1-NNNNE-NN	R911384773	
6,000	1.75	5.9	5.0	0.000070	0.000040	2.7	0.7	1	N	MS2N04-B0BTN-CMSH0-NNNNE-NN	R911384527	
								1	Y	MS2N04-B0BTN-CMSH1-NNNNE-NN	R911384528	
6,000	2.80	12.0	5.0	0.000110	0.000050	3.7	0.7	1	N	MS2N04-C0BTN-CMSH0-NNNNE-NN	R911384531	
								1	Y	MS2N04-C0BTN-CMSH1-NNNNE-NN	R911384532	
6,000	3.85	18,1	5.0	0.000160	0.000040	4.7	0.7	1	N	MS2N04-D0BQN-CMSH0-NNNNE-NN	R911384535	
								1	Y	MS2N04-D0BQN-CMSH1-NNNNE-NN	R911384536	
6,000	3.75	10.6	10.0	0.000170	0.000110	4.0	1.1	1	N	MS2N05-B0BTN-CMSH0-NNNNE-NN	R911384542	
								1	Y	MS2N05-B0BTN-CMSH1-NNNNE-NN	R911384543	
6,000	6.10	20,8	10.0	0.000290	0.000110	5.9	1.1	1	N	MS2N05-C0BTN-CMSH0-NNNNE-NN	R911384546	
								1	Y	MS2N05-C0BTN-CMSH1-NNNNE-NN	R911384547	
6,000	7.90	31.3	10.0	0.000400	0.000110	7.3	1.1	1	N	MS2N05-D0BRN-CMSH0-NNNNE-NN	R911384550	
								1	Y	MS2N05-D0BRN-CMSH1-NNNNE-NN	R911384551	
6,000	3.25	9.5	10.0	0.000480	0.0001100	5.1	1.1	1	N	MS2N06-B1BNN-CMSH0-NNNNE-NN	R911384929	
								1	Y	MS2N06-B1BNN-CMSH1-NNNNE-NN	R911384930	
6,000	6.00	16.0	10.0	0.000390	0.0001100	6.4	1.0	1	N	MS2N06-C0BTN-CMSH0-NNNNE-NN	R911384933	
								1	Y	MS2N06-C0BTN-CMSH1-NNNNE-NN	R911384934	
6,000	9.70	32.0	15.0	0.000650	0.0001400	9.0	1.5	1	N	MS2N06-D0BRN-CMSH0-NNNNE-NN	R911384937	
								1	Y	MS2N06-D0BRN-CMSH2-NNNNE-NN	R911384938	
6,000	9.00	38,4	15.0	0.001400	0.0001400	9.0	1.5	1	N	MS2N06-D1BNN-CMSH0-NNNNE-NN	R911384941	
								1	Y	MS2N06-D1BNN-CMSH2-NNNNE-NN	R911384942	
6,000	13.0	49.0	15.0	0.000890	0.0001400	11.5	1.5	1	N	MS2N06-E0BRN-CMSH0-NNNNE-NN	R911384945	
								1	Y	MS2N06-E0BRN-CMSH2-NNNNE-NN	R911384946	
6,000	7.40	21.0	20.0	0.001970	0.0002600	9.5	2.0	1	N	MS2N07-B1BNN-CMSH0-NNNNE-NN	R911384951	
								1	Y	MS2N07-B1BNN-CMSH1-NNNNE-NN	R911384952	
6,000	12.8	35.7	20.0	0.001200	0.0002600	12.0	2.0	1	N	MS2N07-C0BQN-CMSH0-NNNNE-NN	R911384955	
								1	Y	MS2N07-C0BQN-CMSH1-NNNNE-NN	R911384956	
6,000	11.50	42.2	20.0	0.003050	0.0002600	12.0	2.0	1	N	MS2N07-C1BRN-CMSH0-NNNNE-NN	R911384959	
								1	Y	MS2N07-C1BRN-CMSH1-NNNNE-NN	R911384960	
6,000	18.90	84.8	36.0	0.005290	0.0004100	17.5	2.5	1	N	MS2N07-D1BNN-CMSH0-NNNNE-NN	R911384965	
								1	Y	MS2N07-D1BNN-CMSH2-NNNNE-NN	R911384966	

Automation package

3 ORDERING OPTIONS

- ▶ Single axis
- ▶ Single axis + drive (incl. mains filter/cable (optional))
- ▶ Single axis + drive + software (incl. mains filter/cable (optional)) as plug & play complete solution

Ordering options	System	Options					Further information	
		Motor MS2N	Drive controller		Cable	Mains filter		Software
			Indra-Drive HCS	ctrlX Drive				
1	CKK / CKR	—	—	—	—	—	—	
	MKK / MKR	✓	—	—	—	—	—	
2	EMC	✓	✓	—	Optional	Included	—	
	EMC-HP	—	—	✓	Optional	Included	—	
3		✓	—	✓	Optional	Included	Optional	SFK-H <sup>1)</sup>

<sup>1)</sup> Further related information ➔ Smart Function Kit Handling (SFK-H)



## Motor/controller combinations

Several motor-controller combinations are available in order to provide the most cost-effective solution for every customer application. When dimensioning the drive, always consider the motor-controller combination. For more information on motors, controllers and control systems, please refer to the Rexroth automation solutions ➔ Chapter "Further information".

### IndraDrive drive family

The converters of the IndraDrive C series generate a DC link direct voltage from the grid supply voltage and from it a controlled AC output voltage with variable amplitude and frequency for operation of a servo motor. The compact format contains additional mains connection components, making it particularly suitable for single-axis applications.

#### Version

- ▶ Basic Universal or Basic Universal with Safe Motion
- ▶ Multi-Ethernet for communication with a superior controller
- ▶ More interfaces or integrated controls available
- ▶ For the converter HCS01, a smart function kit for pressing and joining applications is available
- ▶ Brake resistor included
- ▶ Adapters included
- ▶ Separate mains filter included



IndraDrive Cs  
HCS01.1E-W0054



IndraDrive C  
HCS03.1E-W0100

### ctrlX drive family

With ctrlX DRIVE, Bosch Rexroth has developed the most compact, modular drive system worldwide for their customers. In addition to space-saving dimensions and maximum scalability, an almost unlimited number of combination options for the user, mature engineering tools and high energy efficiency are among the advantages of ctrlX DRIVE. The Bosch Rexroth servo motors are the perfect team players in the ctrlX DRIVE portfolio. With compact dimensions, they combine highest dynamics with maximum accuracy for the position, rotary speed and torque values.

- ▶ EtherCAT SOE with Safe Torque Off or EtherCAT SOE with safe field bus
- ▶ Multi-Ethernet for communication with a superior controller
- ▶ More interfaces or integrated controls available
- ▶ Adapters included
- ▶ Separate mains filter included



ctrlX Drive (XCS)

**Motor/controller combinations**

Motor			Drive controller				
	Brake			Without controller	Controller option		
	Without	With			HCS	Controller option	
					BASIC		
					UNIVERSAL		
					MultiEthernet		
					(B-ET) + L3	(B-ET) + S4	
					Safe torque off	Safe motion	
Without motor	000			Without	000	000	
Motor not listed							
MS2N03-B0BYN-CMSHx	203	204	1 cable	000	HCS01-W0008	102	101
MS2N03-D0BYN-CMSHx	207	208			HCS01-W0018	302	301
MS2N04-B0BTN-CMSHx	211	212					
MS2N04-C0BTN-CMSHx	215	216					
MS2N04-D0BQN-CMSHx	219	220					
MS2N05-B0BTN-CMSHx	223	224					
MS2N05-C0BTN-CMSHx	227	228					
MS2N05-D0BRN-CMSHx	231	232			HCS01-W0028	402	401
MS2N06-B1BNN-CMSHx	235	236			HCS01-W0008	102	101
MS2N06-C0BTN-CMSHx	239	240			HCS01-W0028	402	401
MS2N06-D0BRN-CMSHx	243	244					
MS2N06-E0BRN-CMSHx	251	252					
MS2N06-D1BNN-CMSHx	247	248					
MS2N07-B1BNN-CMSHx	255	256			HCS01-W0054	502	501
MS2N07-C0BQN-CMSHx	259	260			HCS01-W0018	302	301
MS2N07-D1BNN-CMSHx	269	270			HCS01-W0028	402	401
MS2N07-C1BRN-CMSHx	263	264			HCS01-W0054	502	501
MS2N07-D0BHA-CMVHx	287	288					
MS2N07-D0BRN-CMVHx	295	296			HCS03-W0100	702	701
MS2N07-E1BNN-CMVHx	299	300					
MS2N07-E0BQN-CMVHx	297	298					
MS2N10-C0BNN-CMVHx	289	290					
MS2N10-D0BHA-CMVHx	291	292	HCS01-W0054	502	501		
MS2N10-E0BHA-CMAHx	293	294	HCS03-W0100	702	701		



The table lists motors that might not be used with this product.

<sup>1)</sup> Further related information → Smart Function Kit Handling (SFK-H)

XCS2	Controller option				Without	Cable option											
	MultiEthernet					Controller HCS / XCS2											
	CAT SOE		SOE <sup>1)</sup>			1 cable			2 cables								
	+ T0	+FSoE + M5	+core +Software_SFK T0	+FSoE +core +Software_SFK M5		5 m	10 m	15 m	5 m	10 m	15 m						
	Safe torque off	Safe motion	Safe torque off	Safe motion													
Without	000	000	000	000	000	000	000	000	000	000	000						
XCS2-W0023	2100	In preparation	2160	2161	105	110	115	-	-	-	-						
XCS2-W0054	3100		3160	3161													
XCS2-W0023	2100		2160	2161													
XCS2-W0054	3100		3160	3161													
XCS2-W0023	2100		2160	2161													
XCS2-W0054	3100		3160	3161													
XCS2-W0070	4100		-	-								-	-	-	205	210	215
XCS2-W0054	3100		3160	3161													
XCS2-W0070	4100		-	-													
XCS2-W0100	5100		-	-													

**Motor/controller/cable combinations**

**Hybrid cable (power and encoder cable combined, 1 cable)**

Motor	Drive controller	Technical data						
		Cable designation Part number	Cable weight (approximately) kg/m	Cable outside diameter D (mm)	Bending radius minimum		Bending cycle	
					Fixed installation	Flexible installation		
MS2N03-B0BYN-CMSHx	HCS01.1E-W0008	RH2-021DBB-NN-xxx,x	0.26	13.0 +/- 0.3	5 x D	7.5 x D	> 5 mill.	
MS2N06-B1BNN-CMSHx		5m R911372050 10m R911372052 15m R911372053						
MS2N03-D0BYN-CMSHx		HCS01.1E-W0018						
MS2N04-B0BTN-CMSHx								
MS2N04-C0BTN-CMSHx								
MS2N04-D0BQN-CMSHx								
MS2N05-B0BTN-CMSHx								
MS2N07-B1BNN-CMSHx								
MS2N05-C0BTN-CMSHx	HCS01.1E-W0028	5m R911372062 10m R911372064 15m R911372065						
MS2N05-D0BRN-CMSHx								
MS2N06-C0BTN-CMSHx								
MS2N06-D0BRN-CMSHx								
MS2N07-C0BQN-CMSHx								
MS2N06-E0BRN-CMSHx	HCS01.1E-W0054	RH2-024DBB-NN-xxx,x						
MS2N07-C1BRN-CMSHx		5m R911374454 10m R911379794 15m R911379795						
MS2N07-D1BNN-CMSHx								
MS2N03-B0BYN-CMSHx	XCS2-W0023	RHB2-021DCB-NN-xxx,x	0.27	13.0 +/- 0.3	5 x D	7.5 x D	> 5 mill.	
MS2N03-D0BYN-CMSHx								
MS2N04-B0BTN-CMSHx								
MS2N04-C0BTN-CMSHx								
MS2N04-D0BQN-CMSHx								
MS2N05-B0BTN-CMSHx								
MS2N05-C0BTN-CMSHx								
MS2N05-D0BRN-CMSHx								
MS2N06-B1BNN-CMSHx								
MS2N06-C0BTN-CMSHx								
MS2N06-D1BNN-CMSHx								
MS2N07-B1BNN-CMSHx								
MS2N07-C0BQN-CMSHx	XCS2-W0054	RHB2-022DCB-NN-xxx,x						
MS2N06-D0BRN-CMSHx			5m R914508036 10m R914508046 15m R914508052					
MS2N06-E0BRN-CMSHx								
MS2N07-C1BRN-CMSHx								
MS2N07-D1BNN-CMSHx								

The table lists motors that might not be used with this product.

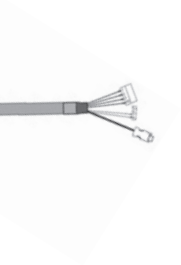
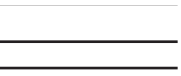





**Motor/controller/cable combinations**

**Power and encoder cable separate, 2 cables**

Motor	Drive controller	Technical data power cable					
		Cable designation Part number	Cable weight (approximately) kg/m	Cable outside diameter D (mm)	Bending radius minimum		Bending cycle
					Fixed installation	Flexible installation	
MS2N07-D0BHA-CMVHx MS2N07-E1BNN-CMVHx	HCS01.1E-W0054	RL2-044DBB-NN-xxx,x					
		5m R911374900	0.23	12.2 +/- 0.5			
		10m R911379527					
15m R911379528							
MS2N07-D0BRN-CMVHx MS2N10-C0BNN-CMVHx MS2N10-D0BHA-CMVHx	HCS01.1E-W0054	RL2-044EBB-NN-xxx,x					
		5m R911374902	0.33	14.8 +/- 0.5	5 x D	7.5 x D	> 5 mill.
		10m R911384595					
15m R911384596							
MS2N07-E0BQN-CMVHx	HCS03.1E-W0100	RL2-046EBB-NN-xxx,x					
		5 m R911376628	0.84	22.2 +/- 1.0			
		10m R911376666					
15m R911376667							
MS2N10-E0BHA-CMAHx	HCS03.1E-W0100	RL2-066HBB-NN-xxx,x					
		5m R911373948	0.84	22.2 +/- 1.0			
		10m R911375037					
15m R911375038							
MS2N07-D0BHA-CMVHx	XCS2-W0054	RLB2-042DBB-NN-xxx,x					
		5m R911397223	0.23	12.2 +/- 0.5			
		10m R911397225					
15m R911397226							
MS2N07-E1BNN-CMVHx	XCS2-W0070	RLB2-042ECB-NN-xxx,x					
		5m R911396693	0.33	14.8 +/- 0.5	5 x D	7.5 x D	> 5 mill.
		10m R911396695					
15m R911396696							
MS2N07-E0BQN-CMVHx	XCS2-W0070	RLB2-042GDB-NN-xxx,x					
		5m R911397170	0.58	18.2 +/- 0.6			
		10m R911397173					
15m R911397174"							
MS2N10-D0BHA-CMVHx	XCS2-W0070	RLB2-063HDB-NN-xxx,x					
		5m R911395186	0.84	22.2 +/- 1.0			
		10m R911395188					
15m R911395189"							
MS2N10-E0BHA-CMAHx	XCS2-W0100	RLB2-063HDB-NN-xxx,x					
		5m R911395186	0.84	22.2 +/- 1.0			
		10m R911395188					
15m R911395189"							

The table lists motors that might not be used with this product.

Technical data encoder cable						
Cable designation Part number	Cable weight (approximately) kg/m	Cable outside diameter D (mm)	Bending radius minimum		Bending cycle	
			Fixed installation	Flexible installation		
 RG2-002AAB-NN-XXX,X 5 m R911371232 10m R911371935 15m R911371936	0.08	7.2 +/-0.2	4 x D	7.5 x D	> 5 mill.	
 RG2-007AAB-NN-XXX,X 5m R911382615 10m R911382617 15m R911382618						

Type designation

MS2N05 type designation / features (example)

		<b>MS2N 05 - C 0 B N N - A S D H 0 - N N N N - N N</b>											
1	Product												
2	Size												
3	Overall length											Special version	17
4	Rotor inertia											Other version	16
5	Winding										Coating	15	
6	Cooling type									Format	14		
7	Encoder performance								Bearings	13			
8	Encoder version							Flange accuracy	12				
9	Electrical connection							Holding brake	11				
								Shaft	10				

Description / options

1	Product	MS2N
2	Size	05
3	Overall length	B, C, D, E
4	Rotor inertia	0 = low inertia / 1 = mean inertia
5	Winding	BY = 9000 1/min / BT = 6000 1/min / BR = 4500 1/min / BQ = 4000 1/min BN = 3000 1/min / BH = 2000 1/min
6	Cooling type	N = self-cooling / A = external cooling axial 230 V/50 Hz
7	Encoder performance	Basic - 16 signal periods, Hiperface® = A Standard - 128 signal periods, Hiperface® (SIL2, PL d)= B Advanced - 20-bit, ACURO®Link (SIL2, PL d)= C Advanced - 20-bit, ACURO®Link (SIL2, PL e)= H
8	Encoder version	Single-turn - 1 revolution absolute = S Multi-turn - 4096 revolutions absolute = M
9	Electrical connection	Two-cable connection 2x M17, rotatable = D Single-cable connection M17, rotatable = H Single-cable connection M23, rotatable = S
10	Shaft	Smooth, without shaft seal ring = H / Smooth, with shaft seal ring = G Keyway, half-spine balancing without shaft seal ring = L Keyway, half-spine balancing with shaft seal ring = K
11	Holding brake	Without holding brake = 0 / size 1, electrically releasing = 1
12	Flange accuracy	Standard = N
13	Bearings	Standard bearing = N
14	Format	B5 / IM3001, PT1000 = N
15	Coating	Standard painting RAL 9005 black = N
16	Other version	None = N / Additional earthing connection = E / Sealing air connection = P
17	Special version	None = NN

► Further information on MS2N synchronous servo motors ➡ Chapter "Further information"



Type designation controller HCS01 (example)

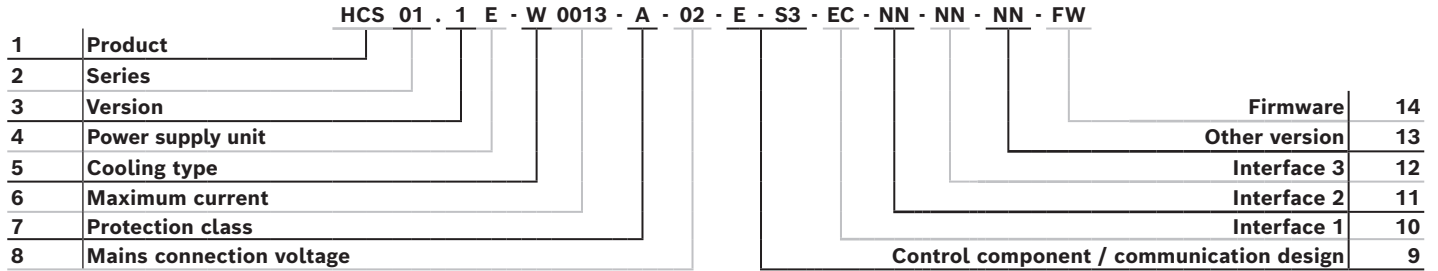

Description / options

<b>1</b>	<b>Product</b>	HCS
<b>2</b>	<b>Series</b>	01
<b>3</b>	<b>Version</b>	1
<b>4</b>	<b>Power supply unit</b>	E = infeed
<b>5</b>	<b>Cooling type</b>	W = air, internal
<b>6</b>	<b>Maximum current</b>	02:0003 = 3 A / 0006 = 6 A / 0009 = 9 A / 0013 = 13 A / 0018 = 18 A 03: 0005 = 5 A / 0008 = 8 A / 0018 = 8 A / 0028 = 28 A / 0054 = 54 A
<b>7</b>	<b>Protection class</b>	A = IP20
<b>8</b>	<b>Mains connection voltage</b>	02 = 3 x AC 110...230 V / 03 = 3 x AC 200...500 V
<b>9</b>	<b>Control component version   Communication</b>	A-CC = Advanced   Sercos III Master / B-ET = Basic   Multi-Ethernet / E-S3 = Economy Sercos III
<b>11</b>	<b>Interface 1</b>	EC = Encoder IndraDyn / Hiperface / 1VSS / TTL / Endat 2.1/2.2
<b>12</b>	<b>Interface 2</b>	CN = CANopen / EC = Multi-encoder interface / EM = Encoder emulation / ET = Multi-Ethernet NN = Not equipped / PB = PROFIBUS
<b>13</b>	<b>Interface 3</b>	L3 = STO (Safe Torque Off) L4 = STO (Safe Torque Off) and SBC (Safe Brake Control) NN = Not equipped / S4 = Safe Motion
<b>14</b>	<b>Other version</b>	NN = None
<b>15</b>	<b>Firmware</b>	

► Further information on the controller ➞ Chapter "Further information"

Type designation controller XCS2 (example)

		<b>XCS2</b>	<b>- W</b>	<b>0100</b>	<b>A</b>	<b>B</b>	<b>N</b>	<b>- 01</b>	<b>N</b>	<b>ET</b>	<b>TO</b>	<b>EC</b>	<b>NN</b>	<b>- S</b>	<b>03</b>	<b>RS</b>	<b>N</b>	<b>1</b>	<b>NNN</b>	<b>N</b>	<b>0</b>	<b>NN</b>		
1	Product																						Other Version	21
2	Cooling type																						Range of functions SM	20
3	Maximum current																						Range of functions RT	19
4	Protection class																						Technology function	18
5	Power unit options																						Protocol - communication	17
6	Connector set																						Subject to export approval	16
7	Control component																						Runtime release	15
8	Panel																						Runtime version	14
9	Communication																						Runtime type	13
10	Hardware option 1																						Hardware option 3	12
11	Hardware option 2																							

Description / options

1	Product	1: X = ctrlX DRIVE / 2: C = converter, feed-in / 3: S = single axis / 4: 2 = generation 2; 1 = generation 1
2	Cooling type	W = air, internal
3	Maximum current	0100 = 100 A (example) / 23, 54, 70, 100 ...
4	Protection class	A = IP20, 3 x AC 200...500 V
5	Power unit options	B = Brake transistor (XCS ≥ W0100) / R = Brake transistor/brake resistor integrated (XCS ≤ W0070)
6	Connector set	N = Without motor connector set
7	Control component	01 = ctrlX DRIVE / 02 = ctrlX DRIVEplus
8	Panel	N = Without panel / A = With panel
9	Communication	ET = Multi-Ethernet (RJ45) / X3 = ctrlX Core
10	Hardware option 1	TO = Safe Torque Off (STO) / M5 = SafeMotion (M5)
11	Hardware option 2	EC = Multi-encoder interface / NN = Not equipped
12	Hardware option 3	ET = Multi-Ethernet / DA = I/O extension digital/analog / NN = Not equipped
13	Runtime type	S = Standard
14	Runtime version	02 = Version 02 (XCS1) / 03 = Version 03 (XCS2)
15	Runtime release	RS = Current release
16	Subject to export approval	N = No (maximum output frequency < 599 Hz)
17	Protocol - communication	0 = Defined via ctrlX CORE apps (XCS2) 1 = Sercos III / 2 = EtherCAT (SoE) / 4 = PROFINET IO
18	Technology function	NNN = None TF1 = Install technology apps (XCS2) TE1 = Install/program technology apps (XCS2) TX1 = Install/program technology apps incl. LIBs (Bosch Rexroth libraries) (XCS2)
19	Range of functions RT	N = DRIVE Runtime P = DRIVE Runtime Productivity
20	Range of functions SafeMotion	0 = Hardware option / 1 ≠ SafeMotion 3 = SafeMotion Speed / 5 = SafeMotion Position
21	Other Version	NN = No

► Further information on the controller ➡ Chapter "Further information"

## Mains filter



Controller / mains filter option						
Controller	Option	Weight (kg)	Mains filter			
			Option	Weight (kg)	Material number	
HCS01-W0008	100 / 101 / 102	1.3	NFD03.1-480-007	007	0.88	R911286917
HCS01-W0018	300 / 301 / 302	2.1	NFD03.1-480-007	007	0.88	R911286917
HCS01-W0028	400 / 401 / 402	2.1	NFD03.1-480-016	016	1.00	R911286918
HCS01-W0054	500 / 501 / 502	4.6	NFD03.1-480-030	030	1.67	R911286919
HCS03-W0100	700 / 701 / 702	8.0	NFD03.1-480-055	055	2.21	R911286920
CtrlX Drive XCS2-W0023A	2100 / 2130	3.0	NFD03.1-480-016	016	1.00	R911286918
	2160 / 2161					
CtrlX Drive XCS2-W0054A	3100 / 3130	6.3	NFD03.1-480-030	030	1.67	R911286919
	3160 / 3161					
CtrlX Drive XCS2-W0070A	4100 / 4130	6.3	NFD03.1-480-055	055	2.21	R911286920
CtrlX Drive XCS2-W0100A	5100 / 5130	18.1	NFD03.1-480-055	055	2.21	R911286920

### Mains filter option

Assembly			R039949992
Option	Material number	Type	
000	Without mains filter		
001	Only CMS: with mains filter		
007	R911286917	NFD03.1-480-007 = 7 A	
016	R911286918	NFD03.1-480-016 = 16 A	
030	R911286919	NFD03.1-480-030 = 30 A	
055	R911286920	NFD03.1-480-055 = 55 A	

► Further information on the controller ► Chapter "Further information"

## Switching system

### Overview of attachment variants

#### Magnetic sensor with free cable end

- 1 Socket and connector
- 2 Sensor
- 3 Cable duct

Alternatively, the sensor can also be fastened by switch mounting plate and cable holder.

See the magnetic sensor with connector.

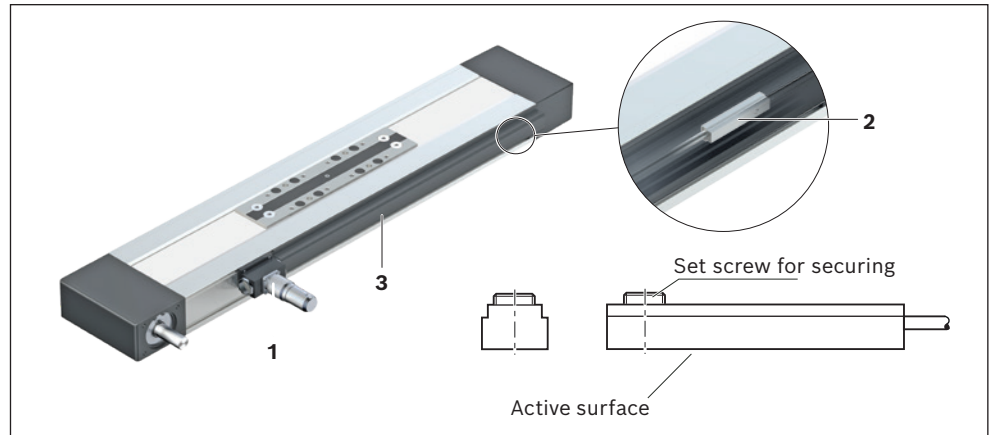

#### Attachment/actuation

A cable duct is needed to fasten the sensors and for cable routing. This is suspended at the side in a slot at the compact module and fastened with set screws (4).

The set screws are included.

The sensors are pushed into the upper T-slot (CKK/CKR-090,-110 and CKK-145) or into the lower T-slot (CKR-145, CKK/CKR-200) of the cable duct and secured with set screws.

Switch activation is done by magnets in the carriage.

CKK/CKR-070	CKK/CKR-090 CKK/CKR-110 CKK-145	CKR-145	CKK/CKR-200

#### Cable duct

Compact module	Material number	Length calculation
<b>CKK/CKR: 070</b>	R039662026	$L_K = L - 5$
<b>CKK: 090, 110, 145, 200</b>	R039662018	$L_K = L - 5$
<b>CKR: 090, 110, 145, 200</b>	R039662018	$L_K = L - 10$

$L_K$  = Length of the cable duct (mm)  
 $L$  = Length of the linear motion system (mm)

#### Socket-connector

Notes:

The socket and connector are not pre-wired.

This allows optimal assignment of switch activation points during commissioning.

One connector is included.

The connector can be mounted in three directions.

For further information, see the section "Socket-connector".

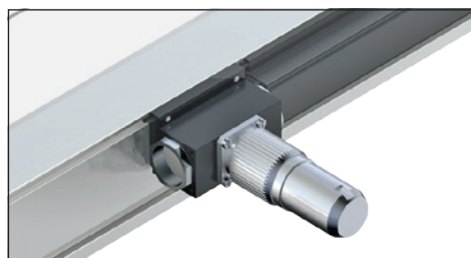

Socket-connector	
Compact module	Material number
<b>CKK/CKR: 070</b>	R117560102
<b>CKK/CKR: 090, 110, 145</b>	R037540000

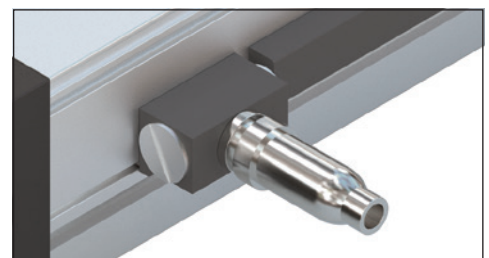

Socket-connector	
Compact module	Material number
<b>CKK/CKR: 200</b>	R037540000

**Magnetic sensor  
with connector**

- 1 Sensor
- 2 Switch mounting plate including set screws (loose) and square nut (**2a**)
- 3 Cable holder including set screw (loose)

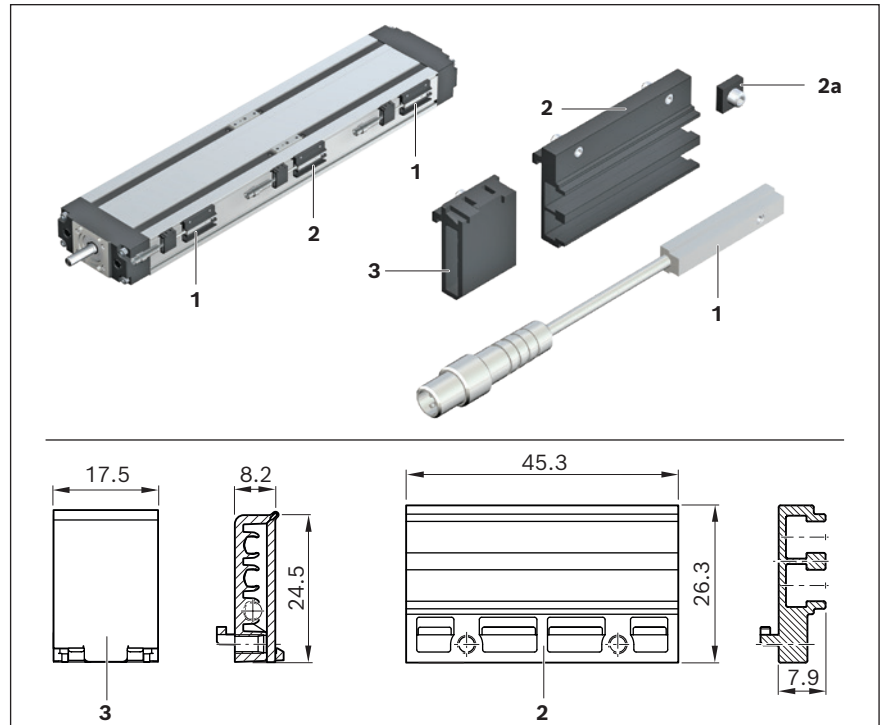

**Attachment/actuation**

A switch mounting plate (**2**) is required to fasten the sensors. This is suspended in the slot on the compact module and fastened with set screws (**4**).

The sensors are pushed into the respective slot on the switch mounting plate and secured with one set screw.

The square nut with set screw (**2a**) serves as a positive stop for the sensor (switch activation point when changing sensors). Parts are included in the scope of delivery of the sensor mounting kit.

Switch activation is done by magnets in the carriage.

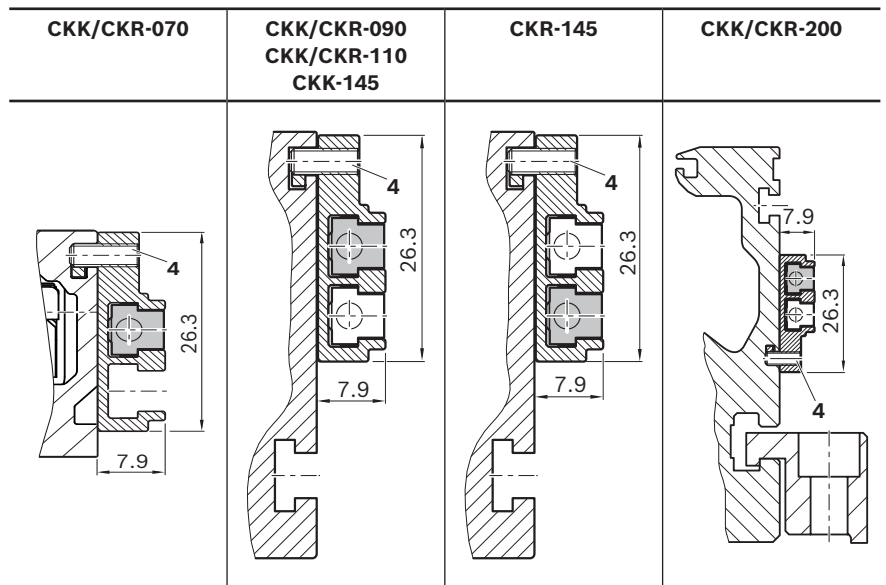

**Switches and attachments**

Item	Material number
1 <b>Magnetic sensor with connector</b>	See the chapter on sensors and accessories
2 <b>Switch mounting plate</b>	R037530021
3 <b>Cable holder</b>	R037530022

**Inductive sensors and mechanical switches for CKK/CKR-200**

- 1 Socket and connector
- 2 Mechanical switch (with attachments)
- 3 Inductive sensor (with attachments)
- 4 Switching cam (attachment only at the connection plate)
- 5 Cable duct

Alternatively, the connection line of the switches can also be fastened by cable holder.

See "Switching system".

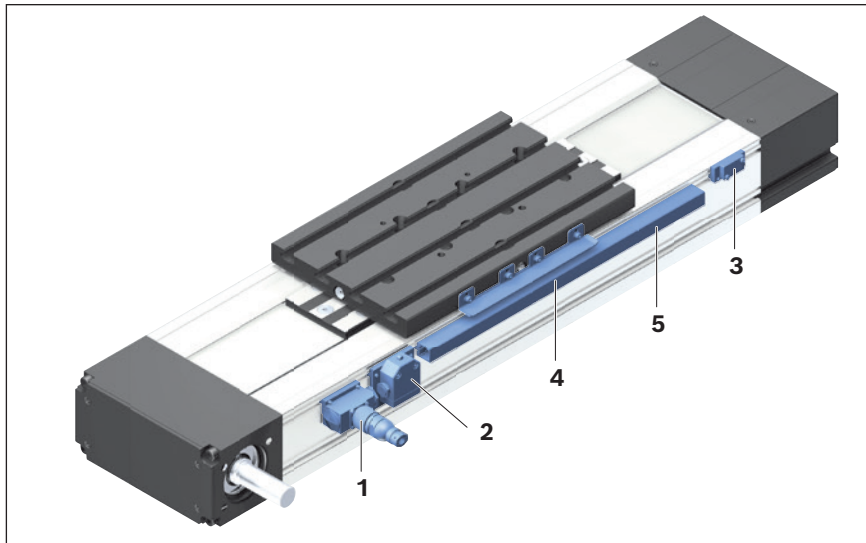

**Attachment/actuation**

The switches are suspended in the upper slot on the compact module and fastened with set screws (6).

The actuation is done using switching cams (4). This is fastened with the screws to the connection plate.

Fastening screws are included.

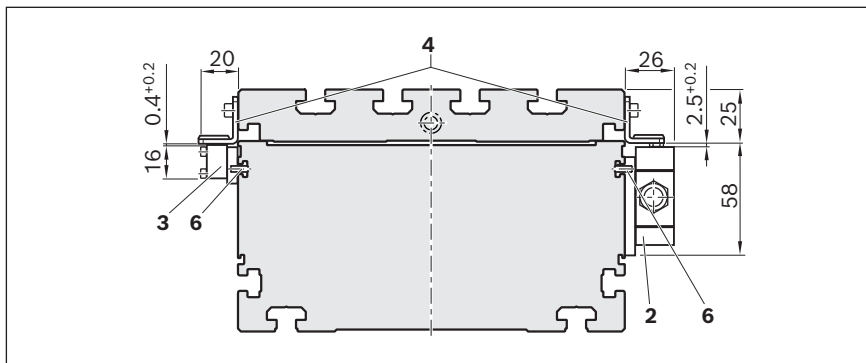

**Switch with attachment**

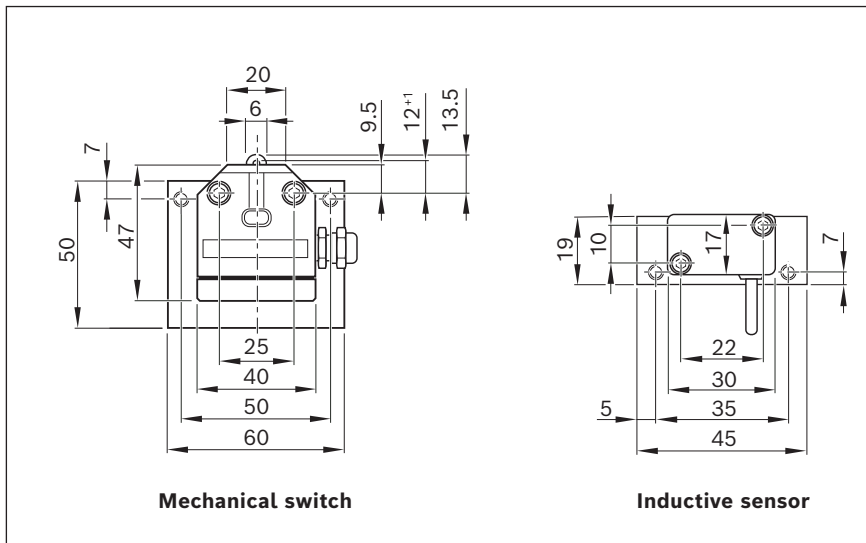

**Cable duct**

The cable duct is fastened in the lateral slots of the frame. Fastening screws widen the profile and ensure that the cable duct is securely mounted.

The cable duct will accommodate up to two cables for mechanical switches and three cables for proximity switches. Fastening screws are included.

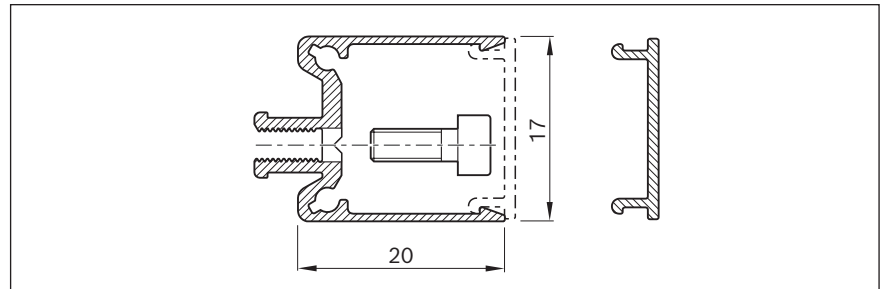

**Cable duct**

Compact module	Length calculation
<b>CKK 200</b>	$L_K = L - 5$
<b>CKR 200</b>	$L_K = L - 10$

$L_K$  = Length of the fastening and the cable duct (mm)  
 $L$  = Length of the linear motion system (mm)

**Socket-connector**

Notes:

The socket and connector are not pre-wired. This allows optimal assignment of switch activation points during commissioning. One connector is included. The connector can be mounted in three directions.

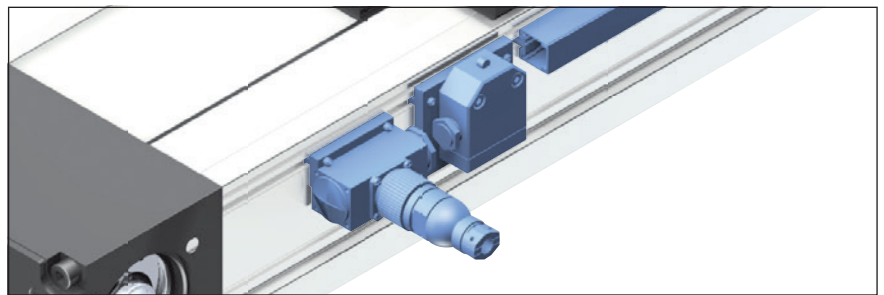

**Switches and attachments**

Item		Material numbers
1	<b>Socket-connector</b>	R117500153
2	<b>Mechanical switch</b>	See the chapter on sensors and accessories
	<b>- Attachments without switch</b>	R117500165
3	<b>Inductive sensor</b>	See the chapter on sensors and accessories
	<b>- Attachments without sensor</b>	R117500152
4	<b>Switching cam<sup>1)</sup></b>	R117500150
5	<b>Cable duct <math>L_K = XX</math> mm</b>	R039662017

<sup>1)</sup> Size 200 switching cam attachment is only possible on connection plate – otherwise customer-designed solution.

**Sensors**

**Magnetic sensor with free cable end**

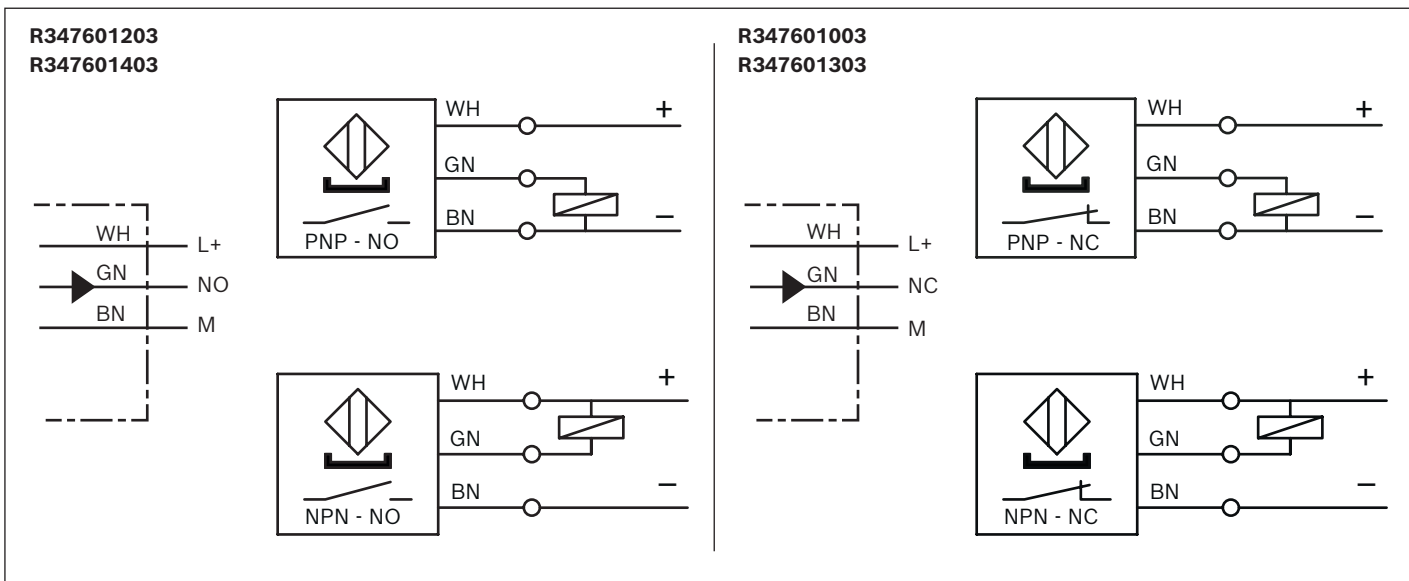
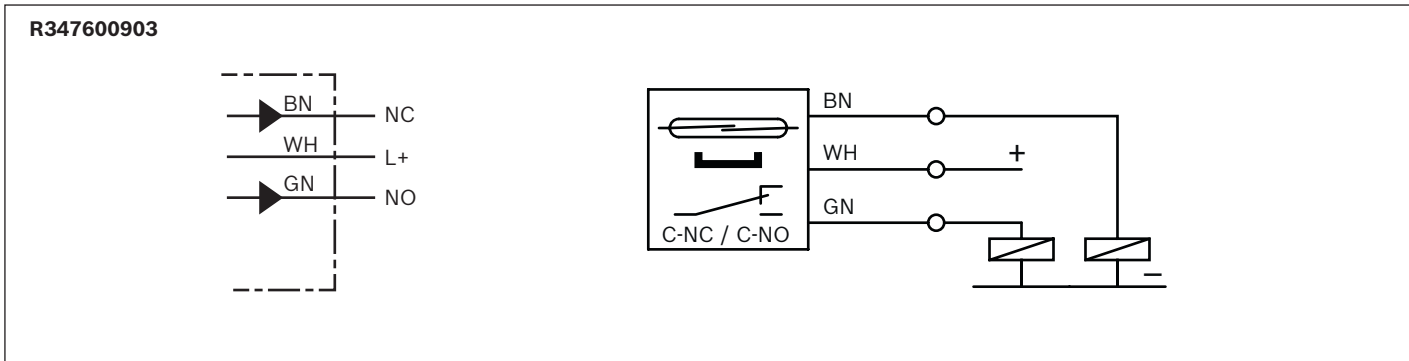
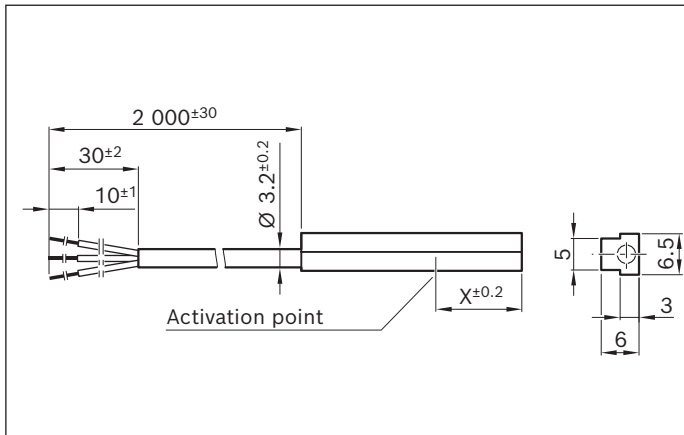
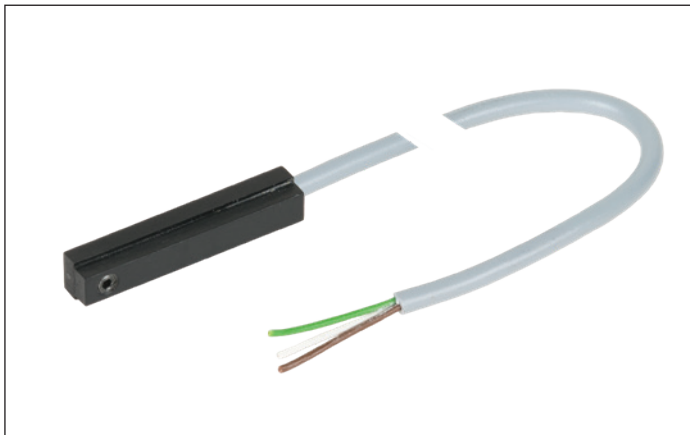



**Material number R347600903**

<b>Use</b>	Reference, limit switch
<b>Material number</b>	R347600903
<b>Designation</b>	R12212
<b>Functional principle</b>	magnetic
<b>Operating voltage</b>	max. 30 V DC
<b>Load current</b>	500 mA
<b>Switching function</b>	REED/changeover contact: (NC: C+NC, NO: C+NO)
<b>Activation point (dimension "X")</b>	9 mm

**Material numbers R347601003 / R347601203 / R347601403 / R347601303**

<b>Use</b>	Limit switch	Reference switch	Limit switch	Reference switch
<b>Material number</b>	R347601003	R347601203	R347601303	R347601403
<b>Designation</b>	H14118	H15637	H15638	H15080
<b>Functional principle</b>	magnetic			
<b>Operating voltage</b>	3.8 - 30 V DC			
<b>Load current</b>	≤ 20 mA			
<b>Switching function</b>	Hall PNP/NC	Hall PNP/NO	Hall NPN/NC	Hall NPN/NO
<b>Activation point dimension "X"</b>	13.65 mm			

**Technical data for R347600903 / R347601003 / R347601203 / R347601403 / R347601303**

<b>Connection type</b>	Cable 2.0 m, 3-pin
<b>Galvanized connection ends</b>	✓
<b>Function indicator</b>	—
<b>Short-circuit protection</b>	—
<b>Reverse polarity protection</b>	—
<b>Switch-on suppression</b>	—
<b>Switching frequency</b>	2.5 kHz
<b>Pulse elongation (off delay)</b>	—
<b>Max. permissible starting speed</b>	2 m/s
<b>Suitable for drag chains<sup>1)</sup></b>	—
<b>Torsion-resistant<sup>1)</sup></b>	—
<b>Welding spark-resistant*</b>	—
<b>Cable cross-section*</b>	3 x 0.14 mm <sup>2</sup>
<b>Cable diameter D</b>	3.2 ±0.20 mm
<b>Static bending radius<sup>1)</sup></b>	—
<b>Dynamic bending radius<sup>1)</sup></b>	—
<b>Bending cycles<sup>1)</sup></b>	—
<b>Maximum permissible travel speed<sup>1)</sup></b>	—
<b>Max. permissible acceleration<sup>1)</sup></b>	—
<b>Ambient temperature</b>	-40 °C to +85 °C
<b>Protection class</b>	IP66
<b>MTTFd (per EN ISO 13849-1)</b>	—
<b>Certifications and approvals<sup>2)</sup></b>	—

<sup>1)</sup> Technical data only for the cast-on connection line at the sensor.

The available extension cables offer even better performance, e.g., when using a cable drag chain (see following pages).

<sup>2)</sup> No (CCC) certificate is required to introduce these products to the Chinese market.

**Magnetic sensor with M8x1 connector**

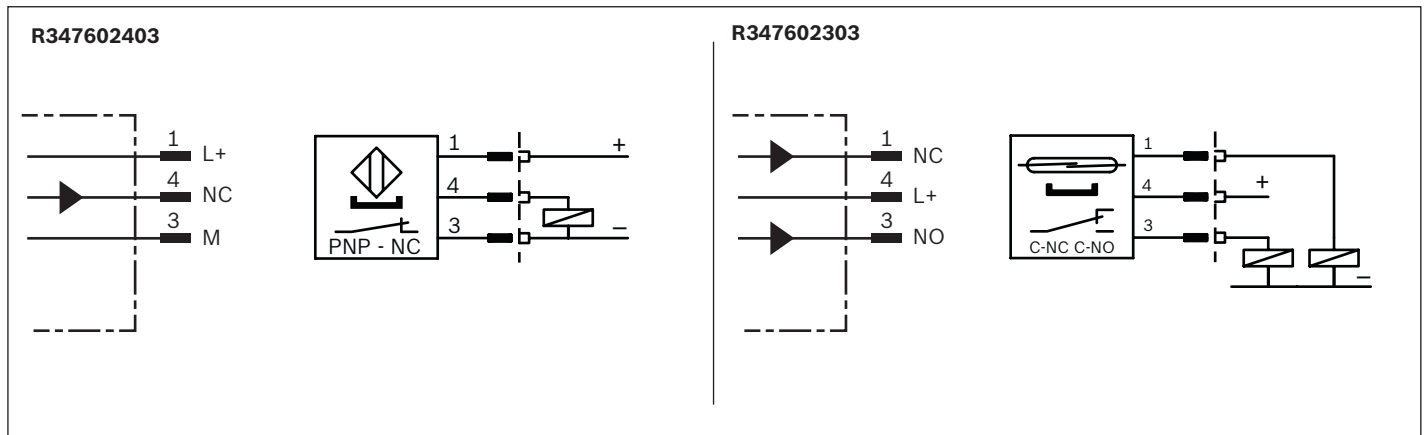
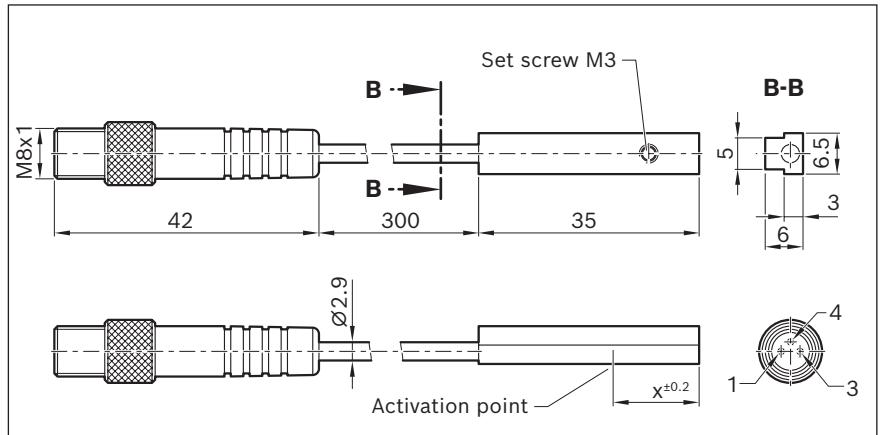

**Material numbers/technical data**

Use	Reference / limit switch	Limit switch
<b>Material number</b>	R347602403	R347602303
<b>Designation</b>	H10706	R10705
<b>Functional principle</b>	magnetic	
<b>Operating voltage</b>	3.8 - 30 V DC	30 V DC
<b>Load current</b>	≤ 20 mA	500 mA
<b>Switching function</b>	Hall PNP/NC	REED/single-pole changeover (NC: C+NC, NO: C+NO)
<b>Activation point dimension "X"</b>	13.65 mm	9 mm
<b>Connection type</b>	0.3 m cable and M8x1 connector, 3-pin with knurled screw connection	
<b>Function indicator</b>	—	
<b>Short-circuit protection</b>	—	
<b>Reverse polarity protection</b>	—	
<b>Switch-on suppression</b>	—	
<b>Switching frequency</b>	2.5 kHz	
<b>Pulse elongation (off delay)</b>	—	
<b>Max. permissible starting speed</b>	2 m/s	
<b>Suitable for drag chains<sup>1)</sup></b>	—	
<b>Torsion-resistant<sup>1)</sup></b>	—	
<b>Weld spark-resistant<sup>1)</sup></b>	—	
<b>Cable cross-section<sup>1)</sup></b>	3 x 0.14 mm <sup>2</sup>	
<b>Cable diameter D<sup>1)</sup></b>	3.2 ±0.20 mm	
<b>Static bending radius<sup>1)</sup></b>	—	
<b>Dynamic bending radius<sup>1)</sup></b>	—	
<b>Bending cycles<sup>1)</sup></b>	—	
<b>Maximum permissible travel speed<sup>1)</sup></b>	—	
<b>Max. permissible acceleration<sup>1)</sup></b>	—	
<b>Ambient temperature</b>	-40 °C to +85 °C	
<b>Protection class</b>	IP66	
<b>MTTFd (per EN ISO 13849-1)</b>	—	
<b>Certifications and approvals<sup>2)</sup></b>	—	

<sup>1)</sup> Technical data only for the cast-on connection line at the sensor.

The available extension cables offer even better performance, e.g., when using a cable drag chain (see following pages).

<sup>2)</sup> No (CCC) certificate is required to introduce these products to the Chinese market.

**Inductive sensor with free line end**

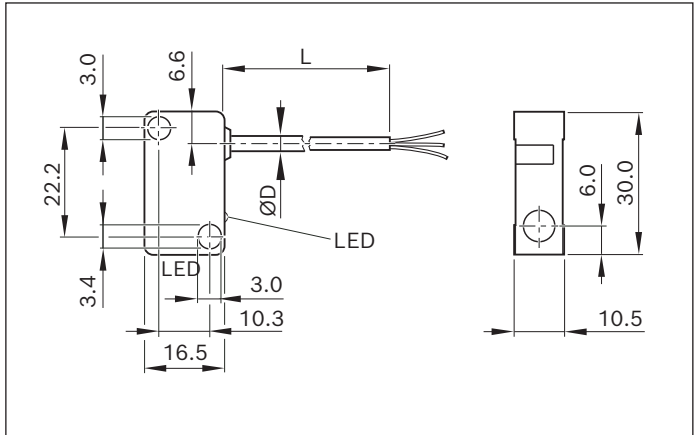
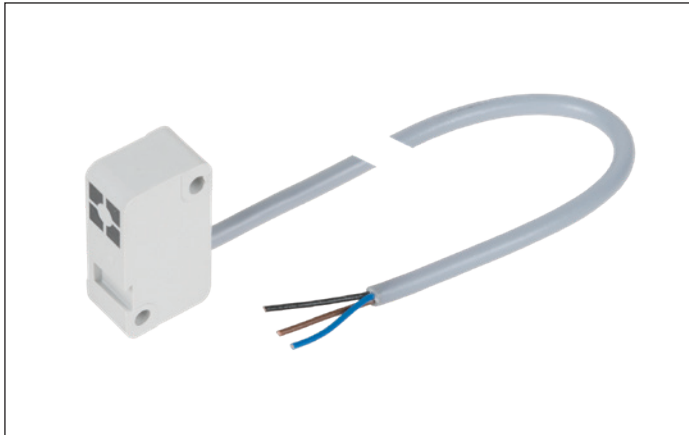

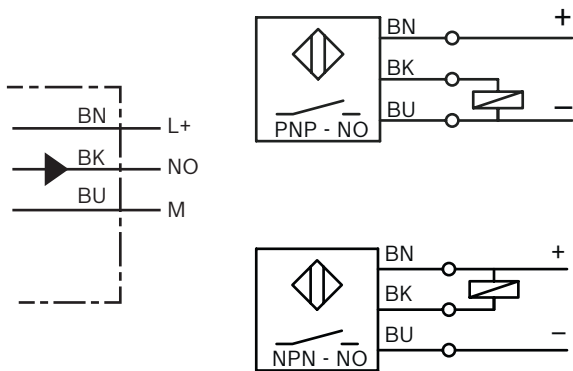

**R345304003**  
**R345304004**

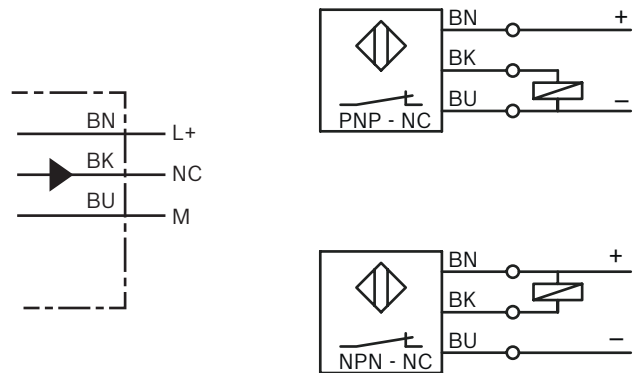

**R345304001**  
**R345304002**



**Material numbers/technical data**

<b>Use</b>	Limit switch	Reference switch	Limit switch	Reference switch
<b>Material number</b>	R345304001	R345304003	R345304002	R345304004
<b>Designation</b>	BES 517-351-NO-C-03	BES 517-398-NO-C-03	BES 517-352-NO-C-03	BES 517-399-NO-C-03
<b>Functional principle</b>	inductive			
<b>Operating voltage</b>	10–30 V DC			
<b>Load current</b>	≤ 200 mA			
<b>Switching function</b>	PNP/NC	PNP/NO	NPN/NC	NPN/NO
<b>Connection type</b>	Line 3 m, 3-pin, free line end			
<b>Function indicator</b>	✓			
<b>Short-circuit protection</b>	✓			
<b>Reverse polarity protection</b>	✓			
<b>Switching frequency</b>	2.5 kHz			
<b>Max. perm. starting speed</b>	depending on the length of the switching cam			
<b>Suitable for drag chains<sup>1)</sup></b>	–			
<b>Torsion-resistant<sup>1)</sup></b>	–			
<b>Weld spark-resistant<sup>1)</sup></b>	–			
<b>Cable cross-section<sup>1)</sup></b>	3 x 0.14 mm <sup>2</sup>			
<b>Cable diameter D<sup>1)</sup></b>	3.5 ±0.15 mm			
<b>Static bending radius<sup>1)</sup></b>	12 mm			
<b>Dynamic bending radius<sup>1)</sup></b>	12 mm			
<b>Bending cycles<sup>1)</sup></b>	–			
<b>Ambient temperature</b>	-40 °C to +70 °C			
<b>Protection class</b>	IP65			
<b>MTTFd (acc. to EN ISO 13849-1)</b>	MTTFd = 830 years		MTTFd = 585 years	
<b>Certifications and approvals<sup>2)</sup></b>	  			

<sup>1)</sup> Technical data only for the cast-on connection line at the sensor.



The available extension cables offer even better performance, e.g., when using a cable drag chain (see following pages).

<sup>2)</sup> No (CCC) certificate is required to introduce these products to the Chinese market.

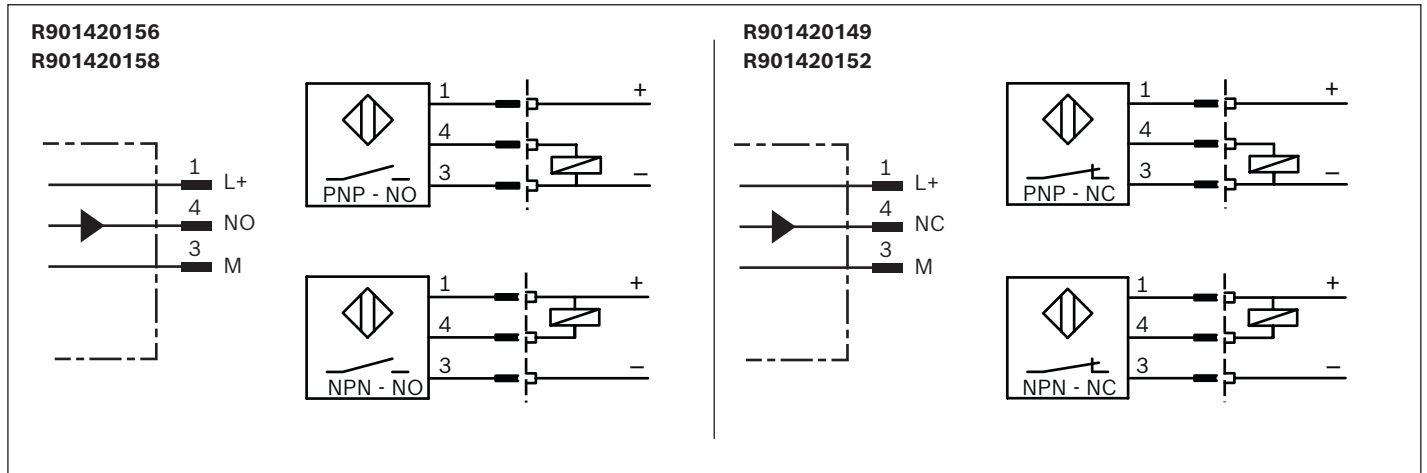
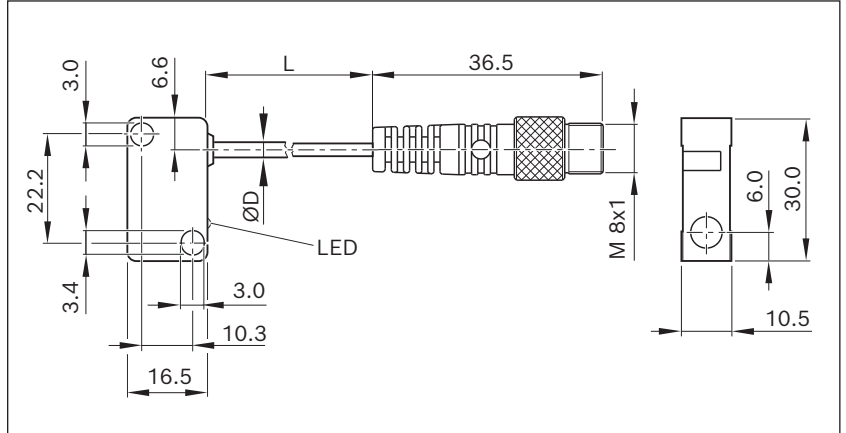
**Inductive sensor with M8x1 connector**



**Material numbers/technical data**

<b>Use</b>	Limit switch	Reference switch	Limit switch	Reference switch
<b>Material number</b>	R901420149	R901420156	R901420152	R901420158
<b>Designation</b>	BES 517-351-NO-C-S49-00.2	BES 517-398-NO-C-S49-00.2	BES 517-352-NO-C-S49-00.2	BES 517-399-NO-C-S49-00.2
<b>Functional principle</b>	inductive			
<b>Operating voltage</b>	10–30 V DC			
<b>Load current</b>	≤ 200 mA			
<b>Switching function</b>	PNP/NC	PNP/NO	NPN/NC	NPN/NO
<b>Connection type</b>	Cable 0.2 m and connector M8 x 1, 3-pin with knurled screw			
<b>Function indicator</b>	✓			
<b>Short-circuit protection</b>	✓			
<b>Reverse polarity protection</b>	✓			
<b>Switching frequency</b>	2.5 kHz			
<b>Max. permissible starting speed</b>	depending on the length of the switching cam			
<b>Suitable for drag chains<sup>1)</sup></b>	–			
<b>Torsion-resistant<sup>1)</sup></b>	–			
<b>Weld spark-resistant<sup>1)</sup></b>	–			
<b>Cable cross-section<sup>1)</sup></b>	3x0.14 mm <sup>2</sup>			
<b>Cable diameter D<sup>1)</sup></b>	3.5 ±0.15 mm			
<b>Static bending radius<sup>1)</sup></b>	12 mm			
<b>Dynamic bending radius<sup>1)</sup></b>	12 mm			
<b>Bending cycles<sup>1)</sup></b>	–			
<b>Ambient temperature</b>	-40 °C to +70 °C			
<b>Protection class</b>	IP65			
<b>MTTFd (per EN ISO 13849-1)</b>	MTTFd = 830 years		MTTFd = 585 years	
<b>Certifications and approvals<sup>2)</sup></b>	  			

<sup>1)</sup> Technical data only for the cast-on connection line at the sensor.

The available extension cables offer even better performance, e.g., when using a cable drag chain (see following pages).



<sup>2)</sup> No (CCC) certificate is required to introduce these products to the Chinese market.

### Switches

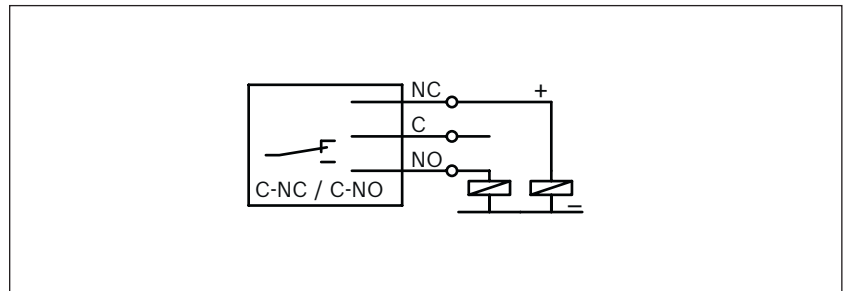
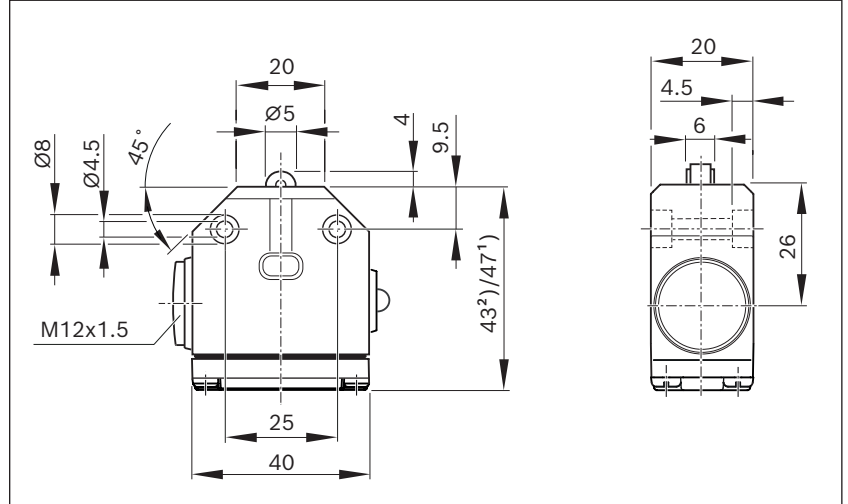
#### Mechanical switch





<b>Material numbers/technical data</b>		
<b>Use</b>	Limit switch	
<b>Material number</b>	R345304016 <sup>1)</sup>	R347600305 <sup>2)</sup>
<b>Designation</b>	BNS 819-X496-99-R-11	BNS 819-X510-99-R-10
<b>Functional principle</b>	mechanical, roller	
<b>Operating voltage</b>	250 V AC	
<b>Load current</b>	≤ 5 A	
<b>Switching function</b>	single-pole changeover/ (NC: C+NC, NO: C+NO)	
<b>Connection type</b>	Screw connection, without line	
<b>Function indicator</b>	-	
<b>Switching frequency</b>	3.3 Hz	
<b>Max. permissible starting speed</b>	1 m/s	
<b>Ambient temperature</b>	-5°C to +85°C	
<b>Protection class</b>	IP67	
<b>B10d value</b>	5x10 <sup>6</sup> (wet area); 10x10 <sup>6</sup> (dependent on current load (dry area))	
<b>Certifications and approvals, housing</b>		
<b>Certifications and approvals, switching element</b>		

**Mechanical switch with M8x1 connector**

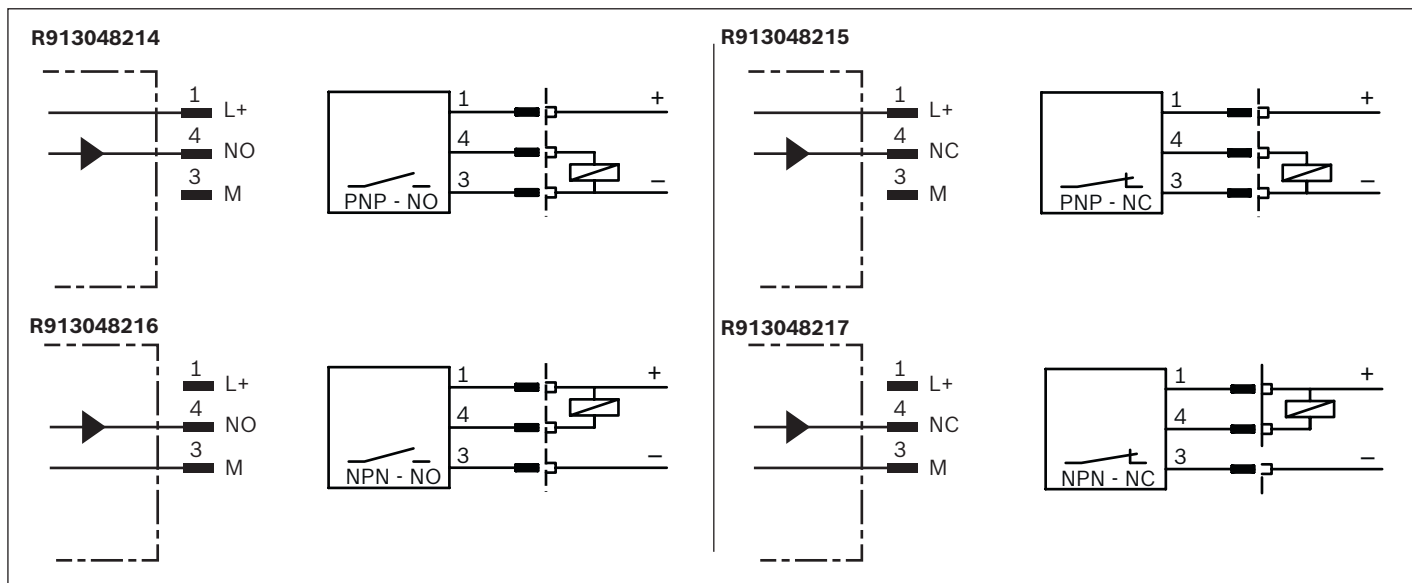
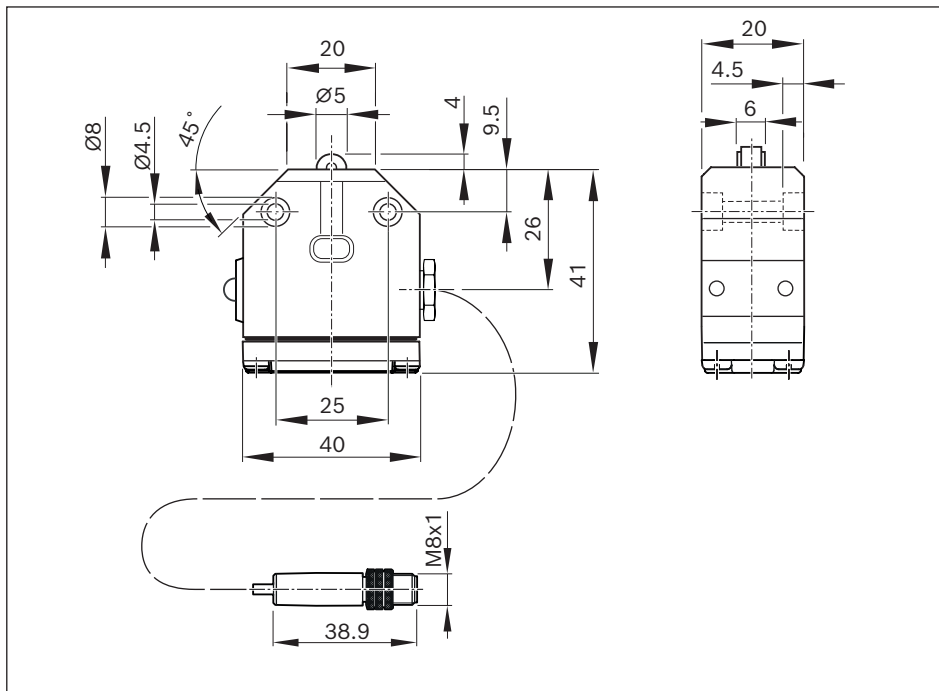

**Material numbers/technical data**

<b>Use</b>	Limit switch	Reference switch	Limit switch	Reference switch
<b>Material number</b>	R913048215	R913048214	R913048217	R913048216
<b>Designation</b>	BNS 819-X1002-99-R-10	BNS 819-X1001-99-R-10	BNS 819-X1004-99-R-10	BNS 819-X1003-99-R-10
<b>Functional principle</b>	mechanical, roller			
<b>Operating voltage</b>	10 - 30 VDC			
<b>Load current</b>	≤ 200 mA			
<b>Switching function</b>	PNP/NC	PNP/NO	NPN/NC	NPN/NO
<b>Connection type</b>	Cable 0.2 m and connector M8 x 1, 3-pin with knurled screw			
<b>Function indicator</b>	—			
<b>Short-circuit protection</b>	—			
<b>Reverse polarity protection</b>	—			
<b>Switching frequency</b>	3.3 Hz			
<b>Max. perm. starting speed</b>	1 m/s			
<b>Suitable for drag chains<sup>1)</sup></b>	—			
<b>Torsion-resistant<sup>1)</sup></b>	—			
<b>Weld spark-resistant<sup>1)</sup></b>	—			
<b>Cable cross-section<sup>1)</sup></b>	3x0.14 mm <sup>2</sup>			
<b>Cable diameter D<sup>1)</sup></b>	4.3 ±0.2 mm			
<b>Static bending radius<sup>1)</sup></b>	12 mm			
<b>Dynamic bending radius<sup>1)</sup></b>	12 mm			
<b>Bending cycles<sup>1)</sup></b>	—			
<b>Ambient temperature</b>	-5 °C to +70 °C			
<b>Protection class</b>	IP65			
<b>B10d value</b>	5x10 <sup>6</sup> (wet area); 10x10 <sup>6</sup> (dependent on current load (dry area))			
<b>Certifications and approvals<sup>2)</sup></b>				

<sup>1)</sup> Technical data only for the cast-on connection line at the mechanical switch.

The available extension cables offer even better performance, e.g., when using a cable drag chain (see following pages).

<sup>2)</sup> No  certificate is required to introduce these products to the Chinese market.

## Extensions

Assembled on one end

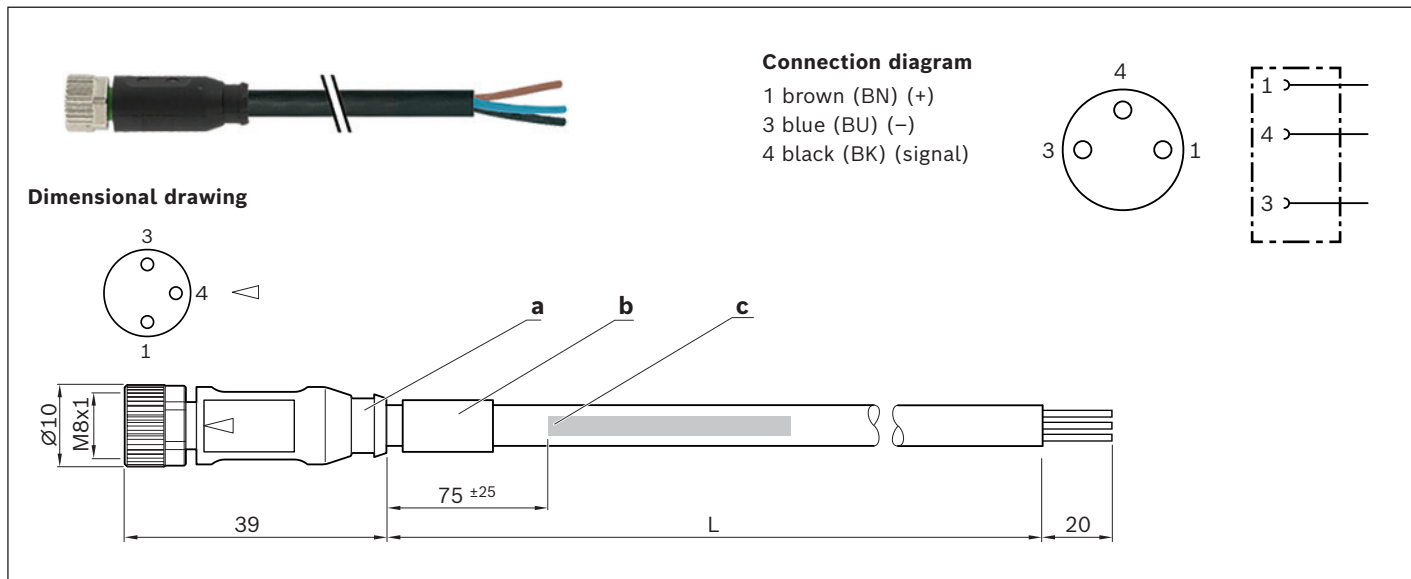

### Material numbers

Use	Extension cable		
<b>Material number</b>	R911344602	R911344619	R911344620
<b>Designation</b>	7000-08041-6500500	7000-08041-6501000	7000-08041-6501500
<b>Length (L)</b>	5.0 m	10.0 m	15.0 m
<b>Connection type 1</b>	Female connector, straight, M8x1, 3-pin		
<b>Connection type 2</b>	Unassembled cable end		

- a) Contour for 6.5 mm corrugated tube (inner diameter)
- b) Cable grommet
- c) Cable printing per printing specification



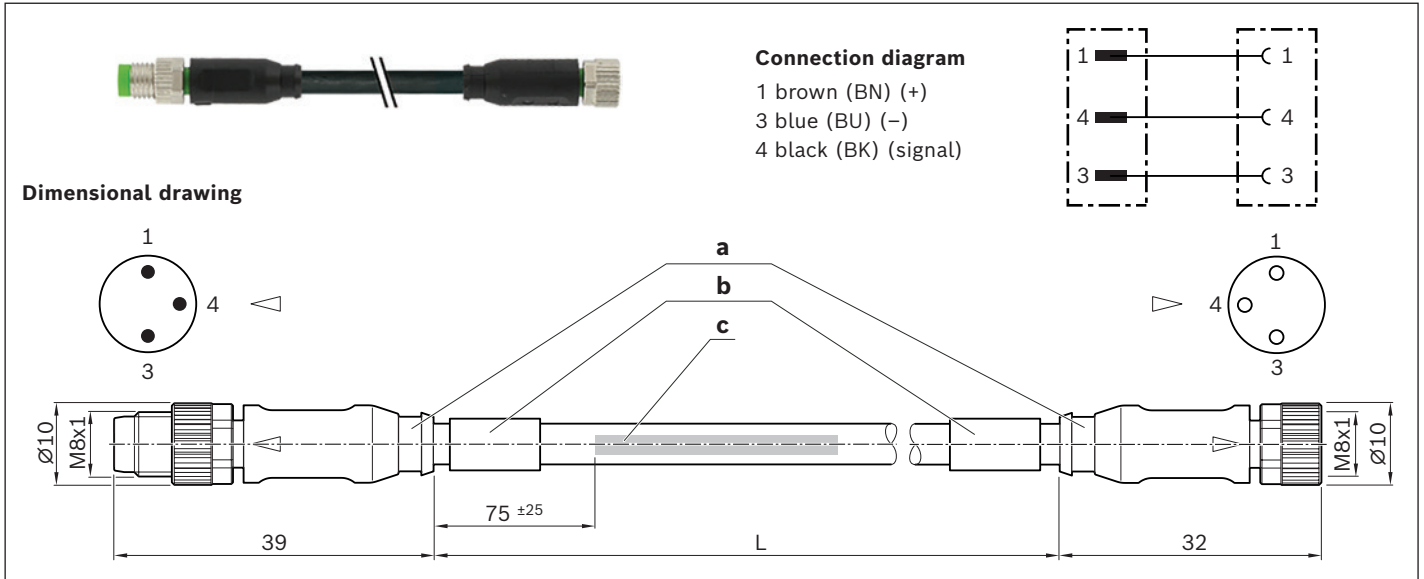

Assembled on two sides



Material numbers

Use	Extension cable				
Material number	R911344621	R911344622	R911344623	R911344624	R911344625
Designation	7000-88001-6500050	7000-88001-6500100	7000-88001-6500200	7000-88001-6500500	7000-88001-6501000
Length (L)	0.5 m	1.0 m	2.0 m	5.0 m	10.0 m
Connection type 1	Female connector, straight, M8x1, 3-pin				
Connection type 2	Connector, straight, M8x1, 3-pin				

Technical data for extensions pre-assembled on one or two sides

Function indicator	-
Operating voltage indicator	-
Operating voltage	10-30 V DC
Type of cable	PUR black
Suitable for drag chains	✓
Torsion-resistant	✓
Weld spark-resistant	✓
Cable cross-section	3x0.25 mm <sup>2</sup>
Cable diameter D	4.1 ±0.2 mm
Static bending radius	≥ 5xD
Dynamic bending radius	≥ 10xD
Bending cycles	> 10 mil.
Max. permissible travel speed	3.3 m/s for 5 m travel range (typ.), up to 5 m/s for 0.9 m travel range
Max. permissible acceleration	≤ 30 m/s <sup>2</sup>
Ambient temperature fixed ext.	-40°C to +85°C
Ambient temperature flexible ext.	-25°C to +85°C
Protection class	IP68
Certifications and approvals	    



a) Contour for 6.5 mm corrugated tube (inner diameter)  
b) Cable grommet

c) Cable printing per printing specification

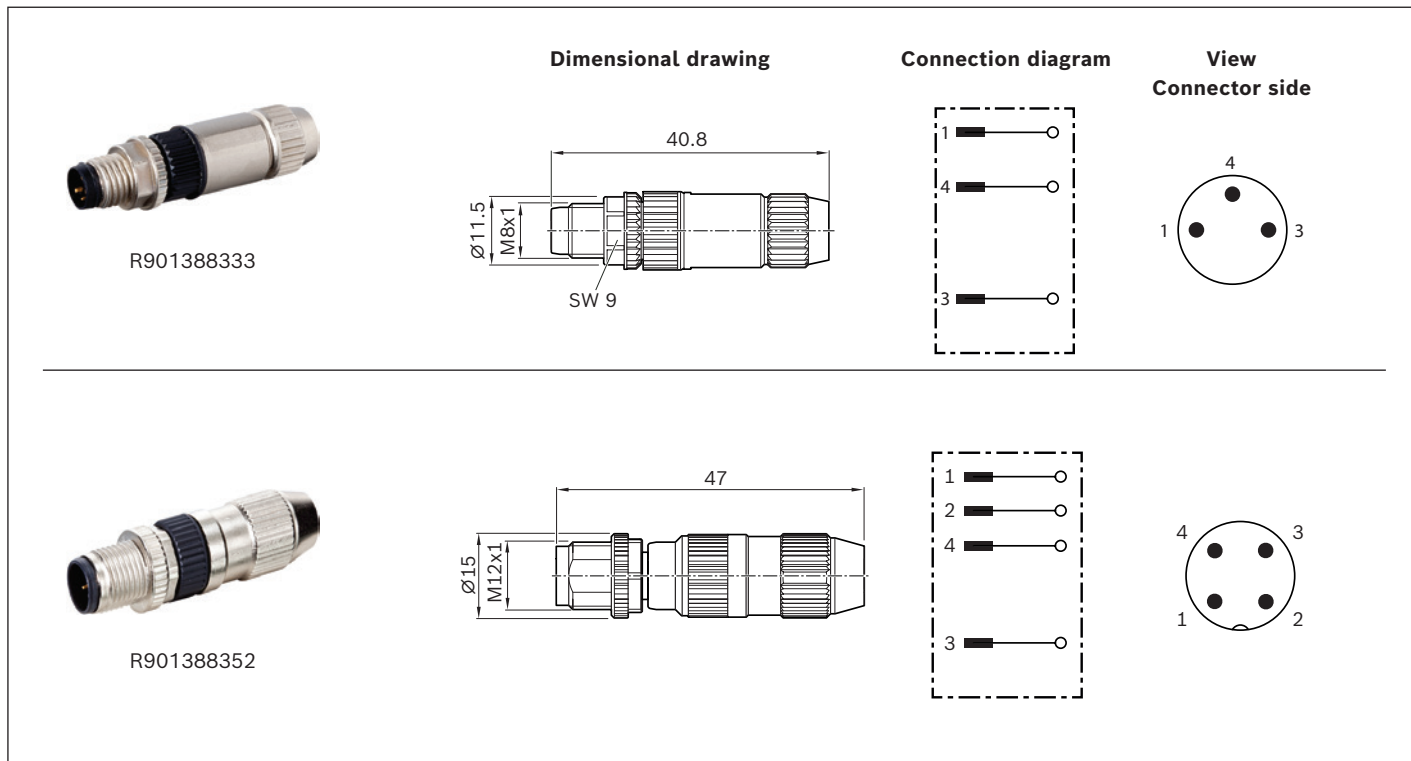

## Connectors





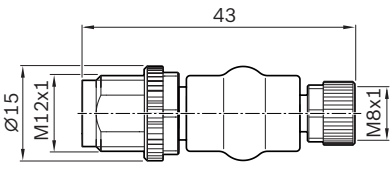
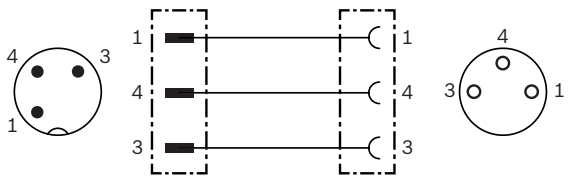

### Material numbers/technical data

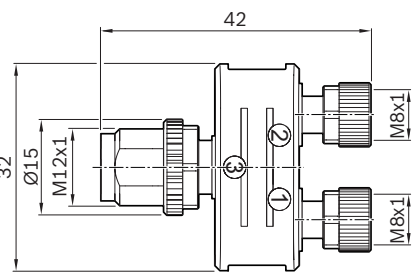
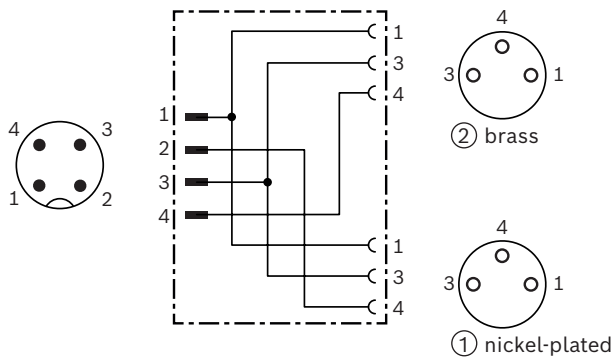
Use	Connector, single	
Material number	R901388333	R901388352
Designation	7000-08331-0000000	7000-12491-0000000
Version	straight	
Operating current per contact	max. 4 A	
Operating voltage	max. 32 V AC/DC	
Connection type	Straight connector, M8x1, 3-pin, IDC, self-locking screw	Straight connector, M12x1, 4-pin, IDC, self-locking screw
Function indicator	-	
Operating voltage indicator	-	
Connection cross-section	0.14 ... 0.34 mm <sup>2</sup>	
Ambient temperature	-25°C to +85°C	
Protection class	IP67 (inserted and bolted)	
Certifications and approvals	  	

**Adapters**

	Dimensional drawing	Connection diagram
 R911344591		
 R911344592		

**Material numbers/technical data**



Use	Adapters	Adapter or distributor
<b>Material number</b>	R911344591	R911344592
<b>Designation</b>	7000-42201-0000000	7000-41211-0000000
<b>Version</b>	straight for 1 sensor	straight, for 1 - 2 sensors
<b>Operating current per contact</b>	max. 4 A	
<b>Operating voltage</b>	max. 32 V AC/DC	
<b>Connection type 1</b>	Straight female connector, M8x1, 3-pin, self-locking screw thread	2 X female connectors, straight, M8x1, 3-pin, self-locking screw thread
<b>Connection type 2</b>	Male connector, straight, M12x1, 3-pin, self-locking screw thread	Straight connector, M12x1, 4-pin, IDC, self-locking screw thread
<b>Function indicator</b>	-	
<b>Operating voltage indicator</b>	-	
<b>Connection cross-section</b>	-	
<b>Ambient temperature</b>	-25°C to +85°C	
<b>Protection class</b>	IP67 (inserted and bolted)	
<b>Certifications and approvals</b>		  

## Distributors

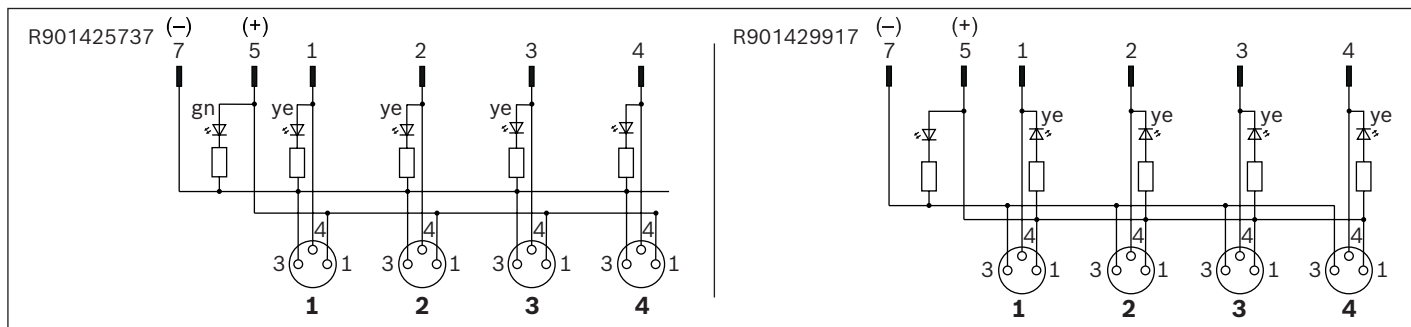
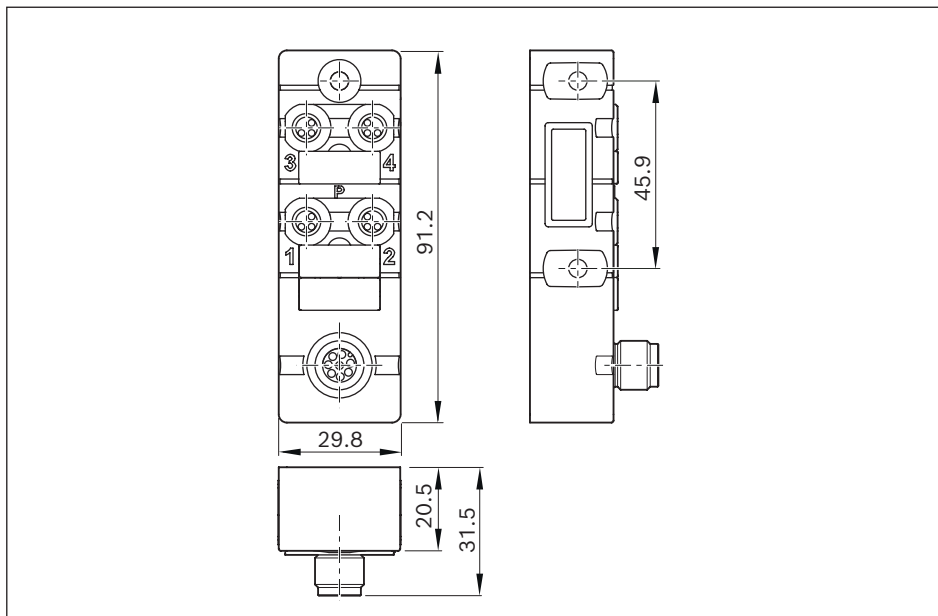
### Passive distributor



### Material numbers/technical data

Use	Passive distributor		
Material number	R901425737	R901429917	R911344592
Designation	8000-84070-0000000	8000-84071-0000000	
Version	straight, for 1 - 4 sensors		
Operating current per contact	max. 2 A		
Operating voltage	24 VDC		
Switching logic	PNP	NPN	
Connection type 1	4x female connectors, straight, M8x1, 3-pin, self-locking screw thread		
Connection type 2	Male connector, straight, M12x1, 8-pin, IDC, self-locking screw thread		
Function indicator	✓		
Operating voltage indicator	✓		
Connection cross-section	-		
Ambient temperature	-20 °C to +70 °C		
Protection class	IP67 (inserted and bolted)		
Certifications and approvals	  		

For technical data and dimensional drawings, see adapter



**Accessories for passive distributors**

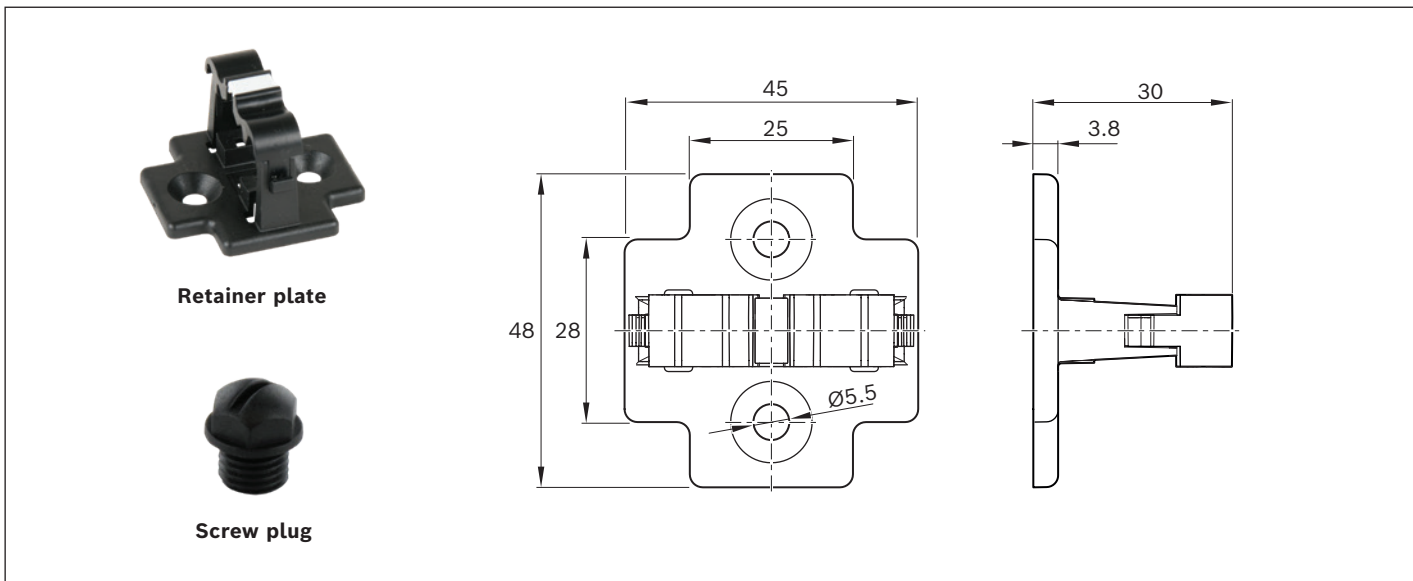

**Material numbers/technical data**



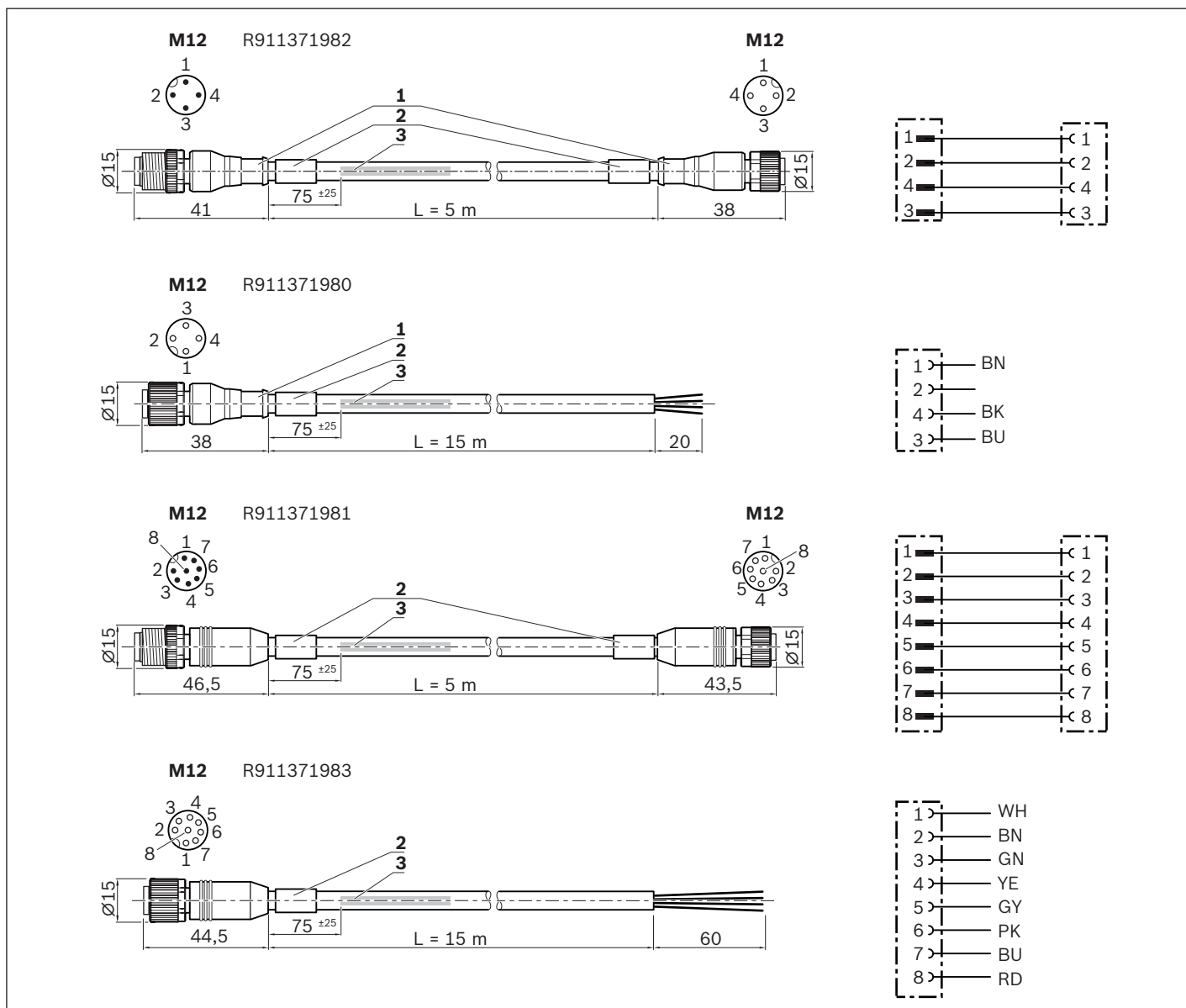
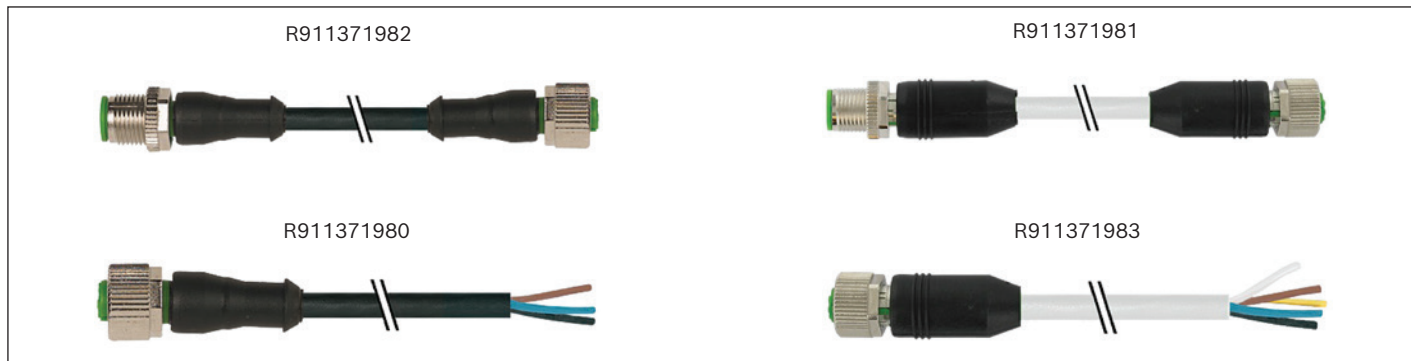

Use	For passive distributor R911344592	For passive distributors R901425737 / R901429917
<b>Retainer plate</b>	R913047341	-
Designation	7000-99061-0000000	-
Set	1 unit	-
<b>Screw plug</b>	-	R913047322
Designation	-	3858627
Set	-	10 units

**Extensions for passive distributors**



1) Contour for conduit pipe with inner diameter of 10  
2) Cable grommet  
3) Cable print per ordering specification 7000-08001

**Material numbers/technical data**

<b>Use</b>	Extension cable for passive distributor R911344592		Extension cable for passive distributors R901425737 / R901429917	
<b>Material number</b>	R911371982	R911371980	R911371981	R911371983
<b>Designation</b>	7000-40021-6540500	7000-12221-6541500	7000-48001-3770500	7000-17041-3771500
<b>Length</b>	5.0 m	15.0 m	5.0 m	15.0 m
<b>Connection type 1</b>	Female connector, straight, M12x1, 4-pin		Female connector, straight, M12x1, 8-pin	
<b>Connection type 2</b>	Male connector, straight, M12x1, 4-pin	Unassembled cable end	Male connector, straight, M12x1, 8-pin	Unassembled cable end
<b>Function indicator</b>	-			
<b>Operating voltage indicator</b>	-			
<b>Type of cable</b>	PUR black		PUR gray	
<b>Operating voltage</b>	30 V AC/DC			
<b>Operating current per contact</b>	max. 4 A per contact		max. 2 A per contact	
<b>Suitable for drag chains</b>	✓			
<b>Torsion-resistant</b>	✓			
<b>Weld spark-resistant</b>	✓			
<b>Cable cross-section</b>	4x0.34 mm <sup>2</sup>		8x0.34 mm <sup>2</sup>	
<b>Cable diameter D</b>	4.7 +/- 0.2 mm		6.2 +/- 0.3 mm	
<b>Static bending radius</b>	≥ 5 x D			
<b>Dynamic bending radius</b>	≥ 10 x D			
<b>Bending cycles</b>	> 10 mil.			
<b>Max. permissible travel speed</b>	3.3 m/s for 5 m travel range (typ.), up to 5 m/s for 0.9 m travel distance			
<b>Max. permissible acceleration</b>	≤ 30 m/s <sup>2</sup>			
<b>Ambient temperature fixed ext.</b>	-40°C to +80°C (90° max. 10,000h)			
<b>Ambient temperature flexible ext.</b>	-25°C to +80°C (90° max. 10,000h)			
<b>Protection class</b>	IP67 (inserted and bolted)			
<b>Certifications and approvals</b>	    			

**Combination examples**

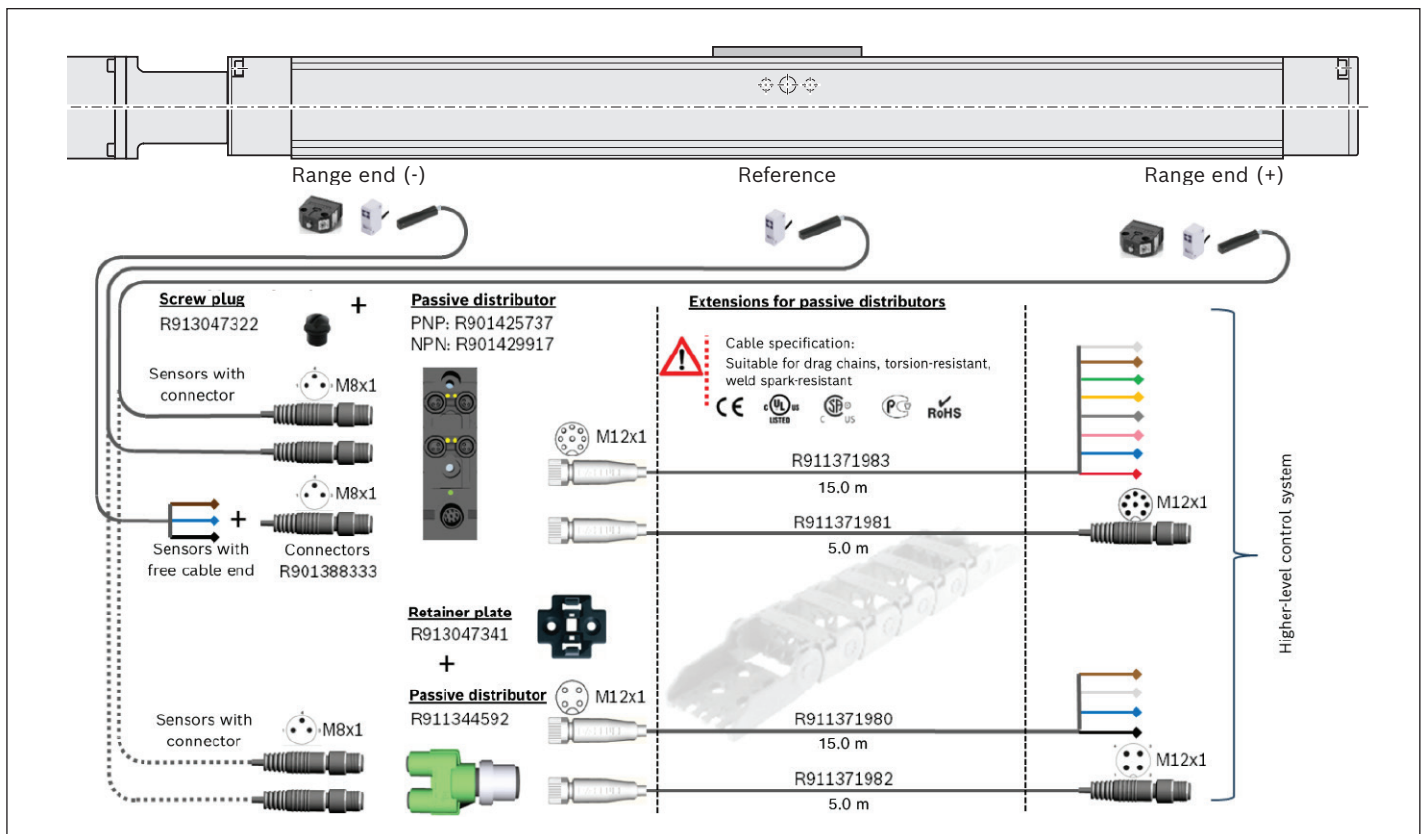
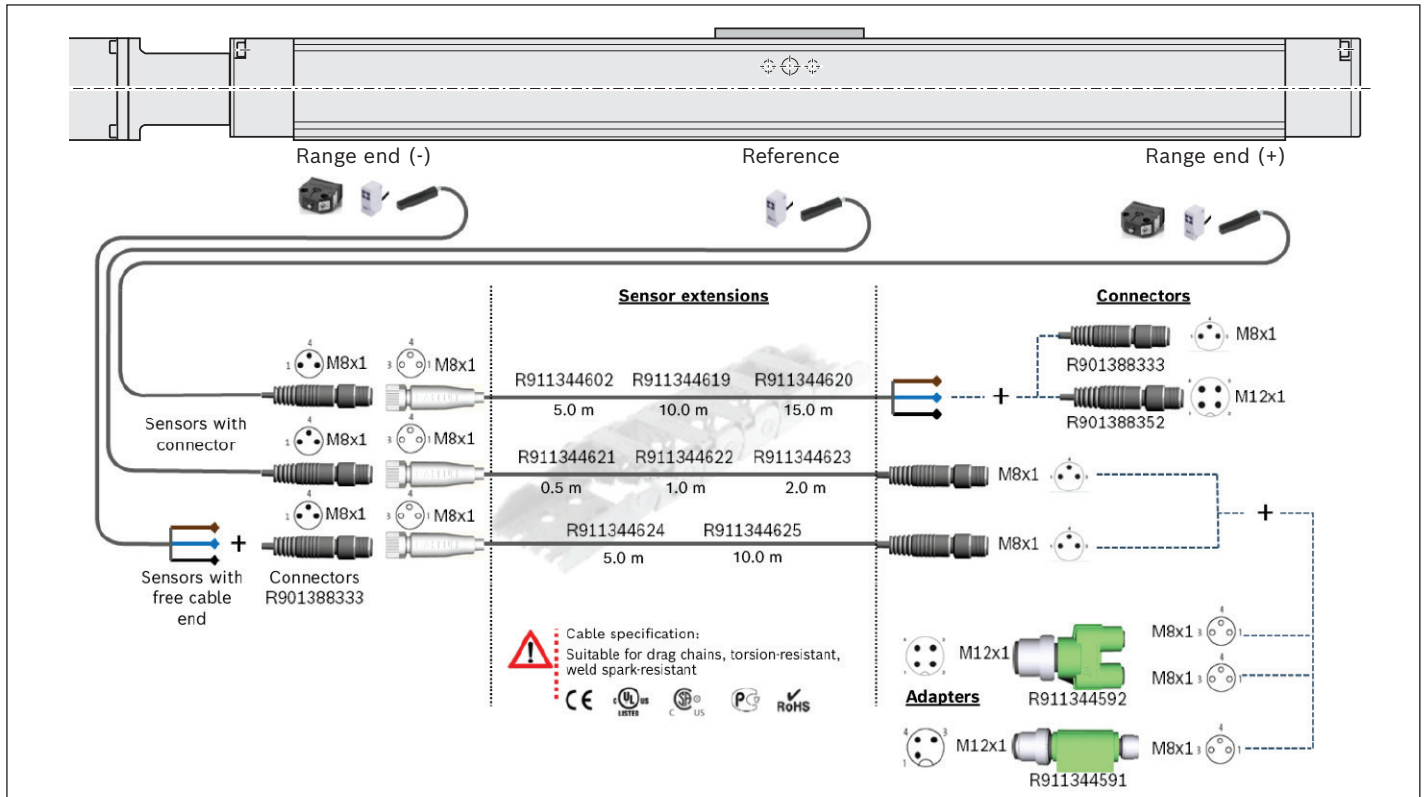



**Socket and connector**

Attach the socket on the side with the magnetic sensors. The socket and connector are not pre-wired. The variable sliding attachment allows switch activation points to be optimized during commissioning. The connector can be mounted in three directions.

R117560102

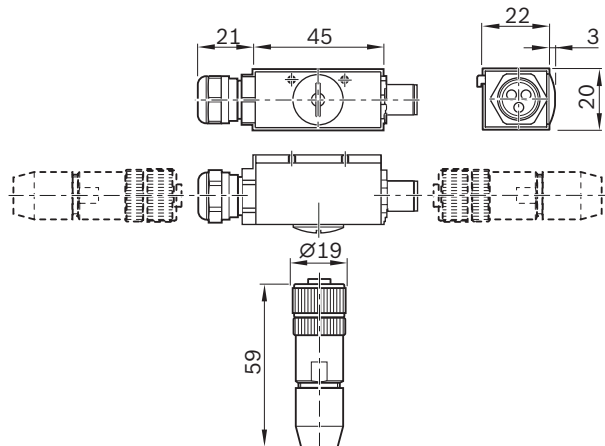
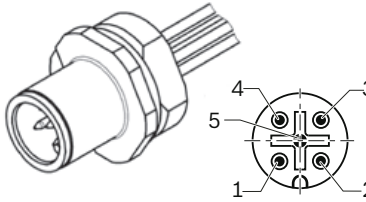

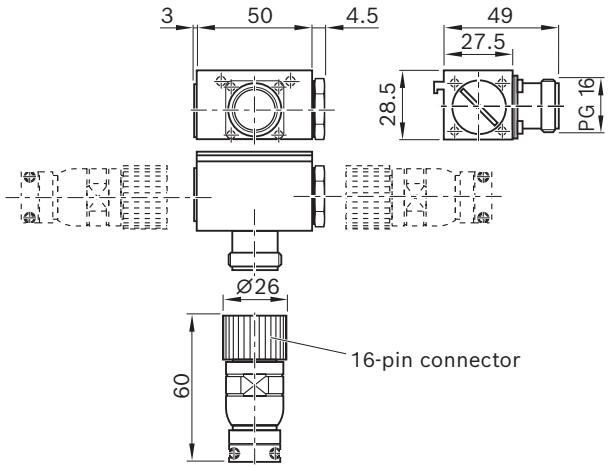
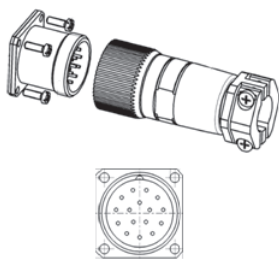

Pin		Color
1	BN	brown
2	WH	white
3	BU	blue
4	BK	black
5	GY	gray

R037540000

R117500153

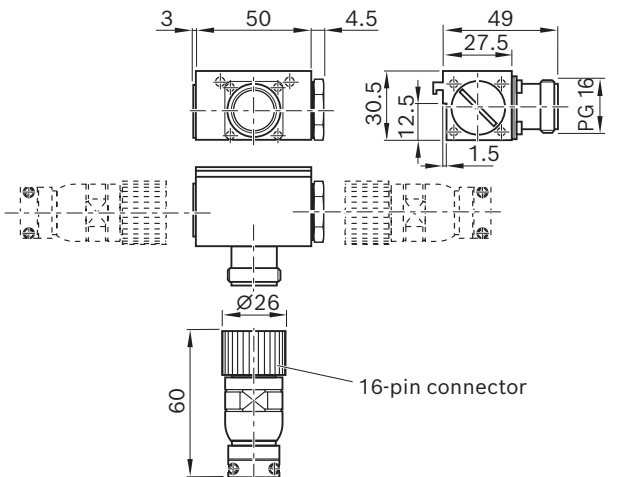
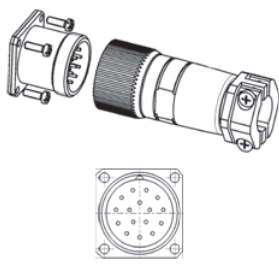
Use	Socket and connector	
<b>Material number</b>	R117560102	R037540000 / R117500153
<b>Designation</b>	for CKK / CKR-070	for CKK / CKR-090, -110, -145, -200
<b>Version</b>	angled, for suspension in the lateral slot of the linear motion system	
<b>Operating current per contact</b>	max. 4 A	max. 8 A
<b>Operating voltage</b>	10–30 V DC	150V AC/DC
<b>Connection type 1</b>	Male connector, straight, M12x1, 5-pin, spring-cage connection	Male connector, straight, 16-pin, soldered connection
<b>Connection type 2</b>	Coupling / flange socket M12x1, 5-pin, with 0.5 m cable	Coupling / flange socket, 16-pin, soldered connection
<b>Cable bushing Housing</b>	Cable gland M16x1.5 with seal (bore 3x3.5 mm) incl. cap and blind plug	1 seal with bore 2x5.5 mm, 1x3.5 mm 1 adaptable seal, max. 14 mm diameter incl. cap and blind plug
<b>Cable bushing, connector</b>	Bolting with pull relief	
<b>Connection cross-section</b>	0.14 ... 0.5 mm	0.14 ... 1 mm
<b>Cable diameter</b>	4 ... 8 mm	10 ... 14 mm
<b>Ambient temperature</b>	-25°C to +85°C	-20°C to +125°C
<b>Protection class</b>	—	
<b>Certifications and approvals</b>	—	

## Service and information

### Operating conditions

#### Normal operating conditions

Ambient temperature with Bosch Rexroth servo motor	0 °C ... 40 °C, loss of performance above 40 °C
Ambient temperature for mechanical system (no undershooting the dew point)	-10 °C ... 60 °C
Travel range $s_{\min}$ <sup>1)</sup>	See the CKK/CKR "technical data" table
Soiling	Not permissible

<sup>1)</sup> Minimum travel range to ensure a reliable lubrication distribution.

#### Required and supplementary documentation

For further instructions and information, please refer to the documentation for this product.

You can find PDF files of these documents on the Internet at [www.boschrexroth.com/mediadirectory](http://www.boschrexroth.com/mediadirectory).

We would also be happy to send you the documents that you want.

If you are unsure about using this product, please contact Bosch Rexroth.



# Lubrication

The profiled rail system and the ball screw assembly must be lubricated (compact modules CKK). The basic lubrication of all other components, e.g. deep-groove ball bearings, cover strips, gear units, etc. is done by the manufacturer.

## Overview of lubrication versions

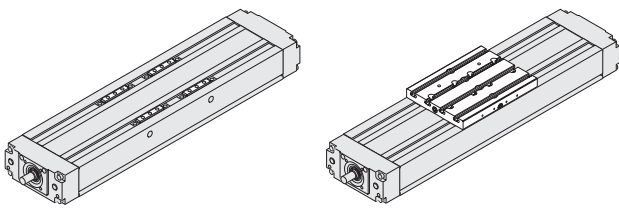
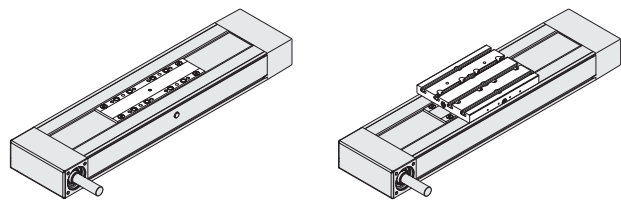
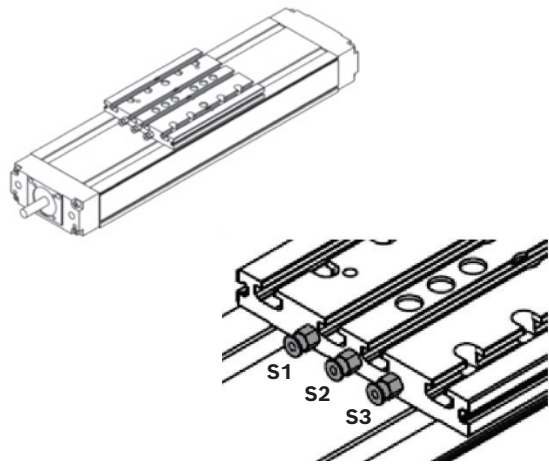
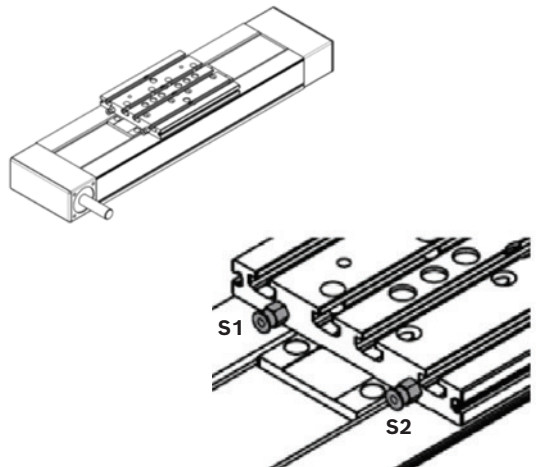
<p style="text-align: center;"><b>Compact modules CKK</b> Lubrication version LSS, LPG</p> <ul style="list-style-type: none"> <li>▶ Grease lubrication using manual grease gun via                             <ul style="list-style-type: none"> <li>- Frame</li> <li>- Carriage</li> <li>- Connection plate</li> </ul> </li> </ul>  <p style="text-align: center;">with connection plate</p>	<p style="text-align: center;"><b>Compact modules CKR</b> Lubrication version LSS, LPG</p> <ul style="list-style-type: none"> <li>▶ Grease lubrication using manual grease gun via                             <ul style="list-style-type: none"> <li>- Frame</li> <li>- Carriage</li> <li>- Connection plate</li> </ul> </li> </ul>  <p style="text-align: center;">with connection plate</p>
<p style="text-align: center;"><b>Lubrication version LCF, LCO</b></p> <ul style="list-style-type: none"> <li>▶ 3 lube fittings</li> <li>▶ Prepared for connection to central lubrication systems</li> </ul> 	<p style="text-align: center;"><b>Lubrication version LCF, LCO</b></p> <ul style="list-style-type: none"> <li>▶ 2 lube fittings</li> <li>▶ Prepared for connection to central lubrication systems</li> </ul> 

- ▶ Further information on the lubrication versions ➡ Page 9
- ▶ Further information on lubrication points, lubrication intervals and lubrication quantities, etc. ➡ Instruction compact modules R320103178 ➡ Chapter "Further information"

## Lubricants

Lubrication version	LSS		LPG	
<b>Size</b>	CKx-110, -145, -200	CKx-070, -090	CKx-110, -145, -200	CKx-070, -090
<b>Basic lubrication</b>	Dynalub 510	Dynalub 520	Preserved, basic lubrication required (see instructions)	
<b>Consistency class</b>	NLGI 2 (DIN 51818)	NLGI 00 (DIN 51818)	-	
<b>Identification</b>	KP2K-20 (DIN 51825)	GP00K-20 (DIN 51826)	-	
<b>Lubrication with grease gun</b>	yes	yes	yes	
<b>Prepared for connection to central lubrication systems</b>	-	-	-	
<b>Recommended lubricants</b>	Dynalub 510 (grease lubricant) (NLGI2 DIN 51818)	Dynalub 520 (liquid grease) (NLGI00 DIN 51818)	Dynalub 510 (grease lubricant) (NLGI2 DIN 51818)	Dynalub 520 (liquid grease) (NLGI00 DIN 51818)
<b>Features</b>	<ul style="list-style-type: none"> <li>• Good water resistance</li> <li>• Corrosion protection</li> <li>• Temperature range: -20 to +80 °C</li> </ul>		<ul style="list-style-type: none"> <li>• Good water resistance</li> <li>• Corrosion protection</li> <li>• Temperature range: -20 to +80 °C</li> </ul>	
<b>Material numbers</b>	R3416 037 00 (400 g cartridge)	R3416 043 00 (400 g cartridge)	R3416 037 00 (400 g cartridge)	R3416 043 00 (400 g cartridge)
	R3416 035 00 (25 kg container)	R3416 042 00 (5 kg bucket)	R3416 035 00 (25 kg container)	R3416 042 00 (5 kg bucket)
<b>Alternative lubricants</b>	<ul style="list-style-type: none"> <li>• Tribol GR 100-2 PD</li> <li>• Elkalub GLS 135/N2</li> </ul>	<ul style="list-style-type: none"> <li>• Tribol GR 100-00 PD</li> <li>• Elkalub GLS 135/N00</li> </ul>	<ul style="list-style-type: none"> <li>• Tribol GR 100-2 PD</li> <li>• Elkalub GLS 135/N2</li> <li>• Tribol GR 100-00 PD</li> <li>• Elkalub GLS 135/N00</li> <li>• Dynalub 520</li> </ul>	<ul style="list-style-type: none"> <li>• Tribol GR 100-00 PD</li> <li>• Elkalub GLS 135/N00</li> </ul>
<b>Alternative lubricants with H1 approval</b>	-	-	<ul style="list-style-type: none"> <li>• Berulub FG H2 SL</li> <li>• Cassida Grease EPS2</li> <li>• VP 874</li> </ul>	<ul style="list-style-type: none"> <li>• Berulub FB 34-00</li> <li>• Elkalub GLS 367/N00</li> </ul>

### Notes on lubrication

- ▶ Follow the product instructions.
- ▶ Do not use lubricants with solid particles (e.g. graphite or MoS<sub>2</sub>).
- ▶ If you use different lubricants than the ones specified, relubrication intervals may be shorter and performance may decrease with short stroke and load ratio; in addition, chemical interactions can take place between the plastics, lubricants and preservative agents. Single-line central lubrication systems also need to be able to pump these lubricants.
- ▶ If using a central lubrication system, make sure all lines and elements are filled with lubricant all the way to the connection to the consumer (carriage) and that there are no air bubbles.
- ▶ Lubricant reservoirs should contain an agitator to ensure the lubricant can flow (avoids hardening in the reservoir).
- ▶ For relubrication, it is not possible to switch from grease to oil lubrication and vice-versa.
- ▶ If environmental factors such as contamination, vibrations, impact loads, etc. are present, we recommend shorter relubrication intervals. Even under normal operating conditions, relubrication is required every two years due to grease aging.
- ▶ Rexroth recommends piston distributors by SKF. These should be installed as close to the carriage lube fittings as possible. Avoid long lines (no longer than 1 m) and narrow line diameters. Install the lines at a gradient.
- ▶ If other consumers are connected to the single-line lubrication system, the weakest link in this chain determines the lubrication cycle.
- ▶ Excess lubricant can accumulate inside of the compact module or flow out and may lead to contamination of the environment
- ▶ Never put a compact module into operation without basic lubrication.

	<b>LCF</b>	<b>LCO</b>
	CKx-090, -110, -145, -200	CKx-090, -110, -145, -200
	required, see instructions	required, see instructions
	NLGI 00 (DIN 51818)	–
	GP00K-20 (DIN 51826)	–
	–	–
	<ul style="list-style-type: none"> <li>• only via single-line piston distributor system</li> <li>• smallest permissible piston distributor size: CKx-090, -110, -145, -200: 0.2 cm<sup>3</sup></li> </ul>	<ul style="list-style-type: none"> <li>• only via single-line piston distributor system</li> <li>• smallest permissible piston distributor size: CKx-090, -110: 0.2 cm<sup>3</sup>; CKx-145: 0.4 cm<sup>3</sup>; CKx-200: 0.6 cm<sup>3</sup></li> </ul>
	Dynalub 520 (liquid grease) (NLGI00 DIN 51818)	Shell Tonna S3 M220 (lubricant oil)
	<ul style="list-style-type: none"> <li>• Good water resistance</li> <li>• Corrosion protection</li> <li>• Temperature range: –20 to +80 °C</li> </ul>	<ul style="list-style-type: none"> <li>• Special demulsifying oil CLP or CGLP as per DIN 51517-3 for machine bed tracks and tool guides</li> <li>• A blend of highly refined mineral base oils and additives</li> <li>• Can be used even when mixed with significant quantities of metalworking fluids</li> </ul>
	R3416 043 00 (400 g cartridge)	–
	R3416 042 00 (5 kg bucket)	–
	<ul style="list-style-type: none"> <li>• Tribol GR 100-00 PD</li> <li>• Elkalub GLS 135/N00</li> </ul>	<ul style="list-style-type: none"> <li>• Special demulsifying oil CLP or CGLP as per DIN 51517-3 for machine bed tracks and tool guides</li> </ul>
	–	–

**⚠ Use of lubricants with H1 approval:**

**Loss of H1 approval**

H1 lubricants or release agents (preservative agents) only have H1 approval if they are separated and unmixed (including at the lubrication point). A blend of two H1 approval lubricants or separating agents does not have H1 approval.

**No approval or authorization for use in the food industry**

Because of the use of H1 lubricants, the compact modules do not have authorization or approval for the food industry.

**Components lubricated at the factory**

Components lubricated by the manufacturer at the factory such as deep-groove ball bearings, cover strips, gears, etc. do not use H1 lubricants.

**⚠ Compact modules with Dynalub 520 (NLGI 00 consistency class) initial greasing must not be pre-lubricated with lubricants of NLGI 2 consistency class!**

For relubrication quantity and relubrication position ⇒ see Compact modules CKK / Compact modules CKR instructions.

**Relubrication interval**

When using the standard lubrication from the manufacturer:

Relubrication interval ⇒ see Compact modules CKK / Compact modules CKR instructions.

Use of Dynalub 520 (NLGI 00) instead of Dynalub 510 (NLGI 2):

The relubrication interval is 75% of the standard relubrication interval ⇒ CKK/CKR instructions.

Use of lubricants with H1 approval:

First relubrication takes place after 20 km. As a guideline value for relubrication intervals, 50% of the standard relubrication intervals must be applied ⇒ See Compact modules CKK / Compact modules CKR instructions.

Parameterization (commissioning)

The nameplate contains reference information on the production of the linear motion system as well as technical commissioning parameters.

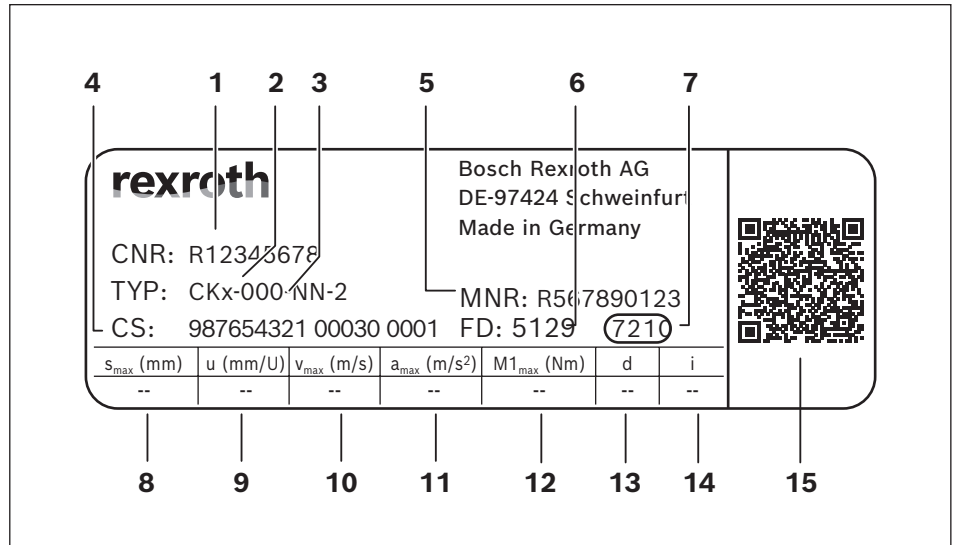

1	CNR	Customer's material number
2	TYP	Short product name
3	110	Size
4	CS	Customer information
5	MNR	Material number
6	FD	Date of manufacture
7	7210	Manufacturing location
8	$s_{max}$	Maximum travel range
9	u	Feed constant without motor attachment
10	$v_{max}$	Maximum speed
11	$a_{max}$	Maximum acceleration rate
12	$M1_{max}$	Maximum drive torque at motor journal
13	d	Direction of motor rotation to travel in positive (+) direction CW = Clockwise CCW = Counterclockwise
14	i	Gear ratio
15		QR code

Documentation

**Standard report**

**Option 01**

The standard report serves to confirm that the checks listed in the report have been carried out and that the measured values lie within the permissible tolerances.

Checks listed in the standard report:

- ▶ Functional checks of mechanical components
- ▶ Functional checks of electrical components
- ▶ Design as per order confirmation

**Measurement of frictional torque of complete system**

**Option 02 (includes option 01)**

The friction torque is measured over the entire travel range.

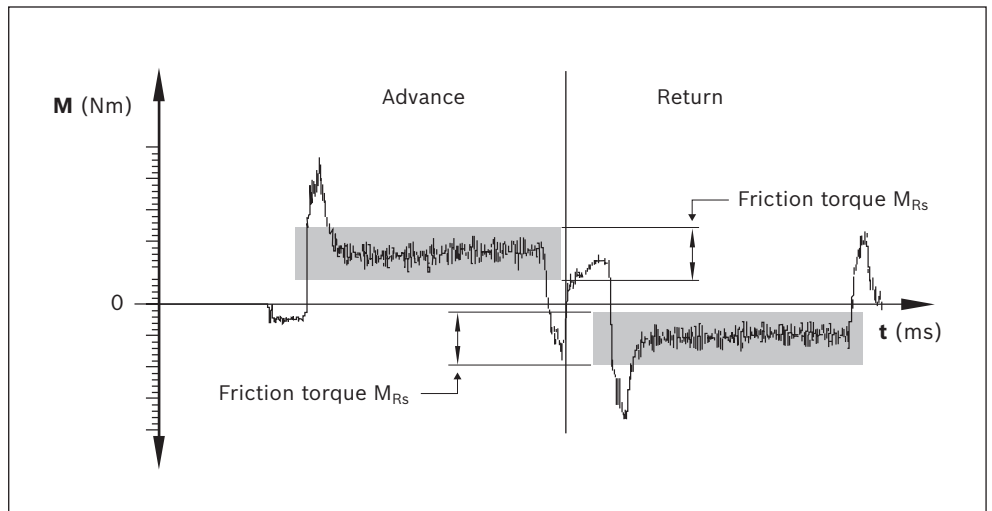

**Lead deviation of the ball screw assembly with compact modules**  
**CKK**

**Option 03 (includes option 01)**

In addition to graphical representation (see illustration), a measurement report is supplied in table form.

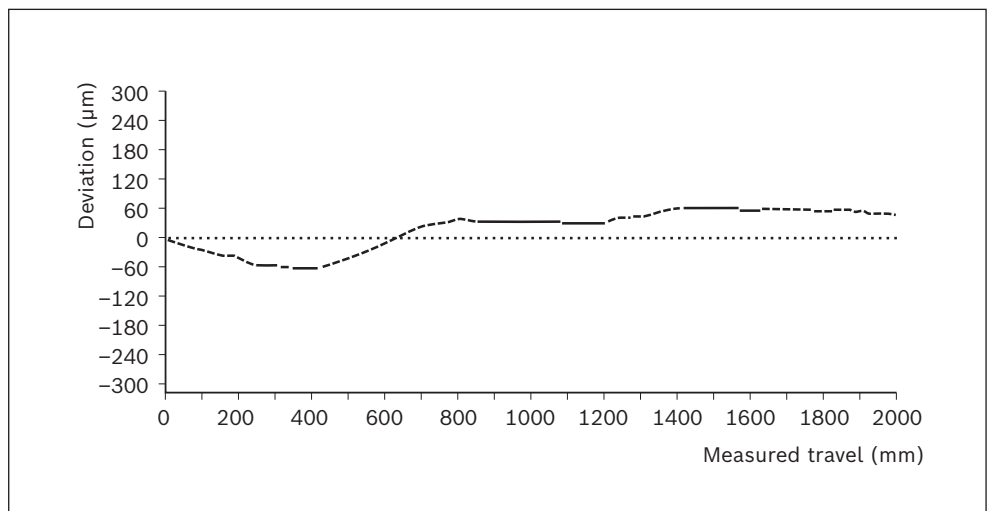

# Project planning/calculation

## Calculation principles

<b>Calculation principles</b>	<b>142</b>
Length calculation	142
Note on dynamic load capacities and moments	143
Maximum permissible load	144
Life expectancy calculation of the linear guide	144
Service life of ball screw assembly or fixed bearing	145
<b>Drive sizing</b>	<b>146</b>
Basic principles	147
Drive sizing with motor shaft as reference point	148
General motor preselection	150
<b>Calculation examples</b>	<b>152</b>
Calculation example CKK	152
Calculation example CKR	156
<b>For the abbreviations refer to the "Abbreviations" chapter</b>	<b>160</b>

### Length calculation of the linear motion system

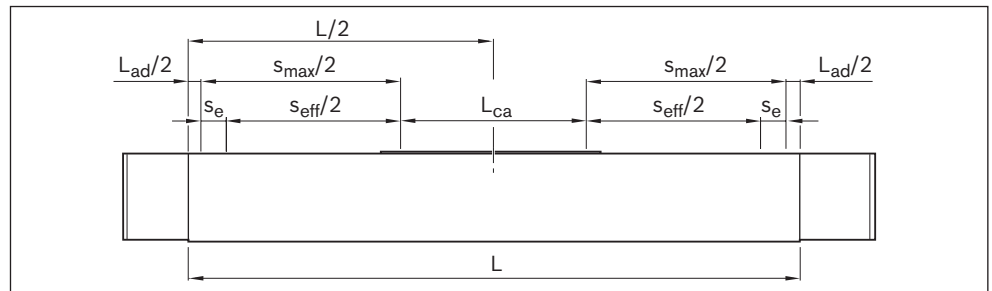

For length calculation values, see chapter "Technical Data" of the relevant compact module (CKK/CKR)

$$L = s_{\text{eff}} + 2 \cdot s_e + L_{\text{ca}} + L_{\text{ad}}$$

### Effective stroke

$$s_{\text{eff}} = s_{\text{max}} - 2 \cdot s_e$$

Stroke: maximum distance from carriage center to the outer-most switch activation points.

Excess travel: Excess travel must be greater than braking distance. The acceleration travel can be adopted as the guideline value for the braking distance.

### Mass of the linear motion system

Weight calculation:

- ▶ without motor
- ▶ without switch mounting
- ▶ without motor attachment

$$m_s = k_{\text{g fix}} + k_{\text{g var}} \cdot L + m_{\text{ca}}$$

**Note on dynamic load capacities and moments**

Determination of the dynamic load capacities and moments is based on a total travel of 100,000 m. Often only 50,000 m of total travel are actually stipulated.  
 For comparison: Multiply values  $C$ ,  $M_t$  and  $M_L$  by a factor of 1.26.

**Suitable loads**

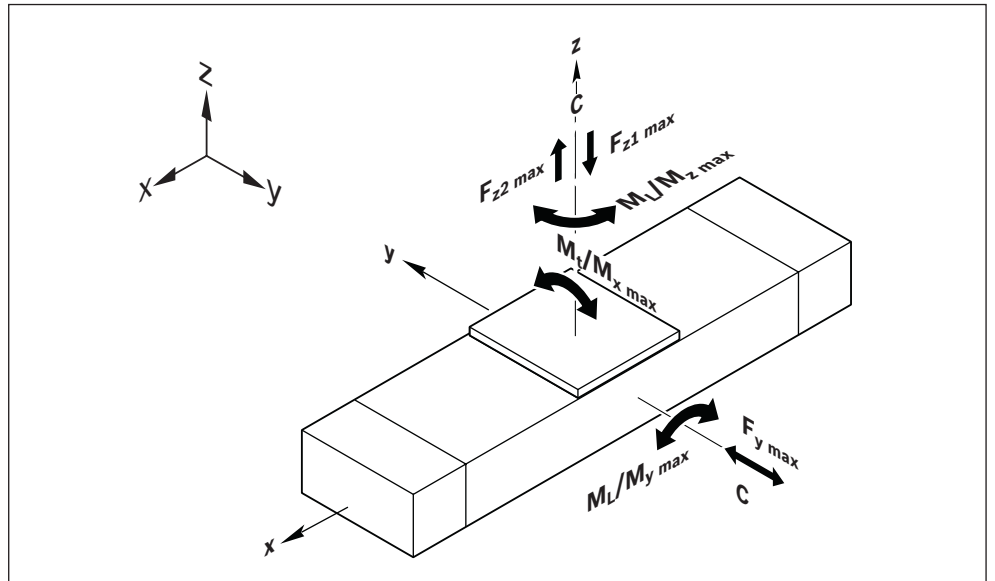

Regarding the desired service life, general loads for  $F_{mgw}$ ,  $F_{mbs}$  should not exceed around 20% of the dynamic characteristic values ( $C_{gw}$ ,  $C_{bs}$ ).

See "Project planning" chapter.

Do not exceed the technical data for the linear motion system.

**Application point of the effective force ( $Z_1$ )**

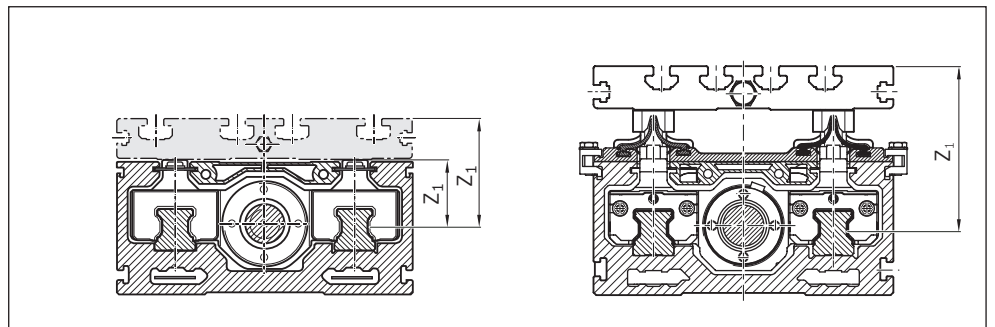

**Modulus of elasticity E**

$E = 70,000 \text{ N/mm}^2$

### Maximum permissible load

When selecting linear motion systems, it is essential to consider the maximum permissible load and force tolerances according to the table. The values depend on the system. In other words, the tolerances are determined not only by the load capacities of the bearing points but are also based on design and material.

Conditions for combined loads:

$$\frac{|F_y|}{F_{y \max}} + \frac{|F_z|}{F_{z \max}} + \frac{|M_x|}{M_{x \max}} + \frac{|M_y|}{M_{y \max}} + \frac{|M_z|}{M_{z \max}} \leq 1$$

### Life expectancy calculation of the linear guide

The service life of the rolling bearing points contained in a linear motion system can be calculated using the formulas given below. The roller bearing points that determine the life of a linear motion system with ball screw assembly are the linear guide, the ball screw assembly (nut) and the fixed bearing. The linear guide in the linear motion system must withstand the load as well as any process forces that occur.

**⚠ The calculated service life specification for the linear motion system is determined by the shortest of the separately determined service life values for linear guide, ball screw assembly or fixed bearing.**

Where the operating conditions vary (speed and load), the service life must be calculated using the average values  $v_{mgw}$  and  $F_{mgw}$ .

Nominal service life in meters:

$$L_{gw} = \left( \frac{C_{gw}}{F_{mgw}} \right)^3 \cdot 10^5$$

Nominal service life in hours:

$$L_{hgw} = \frac{L_{gw}}{3600 \cdot v_{mgw}}$$

Dynamically equivalent load on bearing of the guideway:

$$F_{mgw} = \sqrt[3]{|F_{eff1}|^3 \cdot \frac{q_{t1}}{100\%} + |F_{eff2}|^3 \cdot \frac{q_{t2}}{100\%} + |F_{eff3}|^3 \cdot \frac{q_{t3}}{100\%} + |F_{effn}|^3 \cdot \frac{q_{tn}}{100\%}}$$

The following applies to linear motion systems:

$$F_{eff} = F_{comb}$$

Combined equivalent bearing load:

$$F_{comb} = |F_y| + |F_z| + C_{gw} \cdot \frac{|M_x|}{M_t} + C_{gw} \cdot \frac{|M_y|}{M_L} + C_{gw} \cdot \frac{|M_z|}{M_L}$$

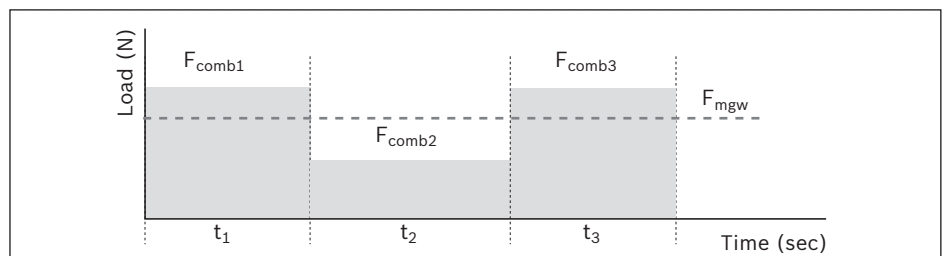

Average linear speed of the guideway:

$$v_{mgw} = \frac{|v_1| \cdot q_{t1} + |v_2| \cdot q_{t2} + \dots + |v_n| \cdot q_{tn}}{100\%}$$



**Service life of ball screw assembly or fixed bearing**

Where the operating conditions vary (rotary speed and load), the service life must be calculated using the average values  $F_{mbs}$  and  $n_m$ .

Nominal service life in revolutions:

$$L_{bs} = \left( \frac{C_{bs}}{F_{mbs}} \right)^3 \cdot 10^6$$

Nominal service life in hours:

$$L_{hbs} = \frac{L_{bs}}{60 \cdot n_m}$$

Dynamically equivalent load on bearing of the ball screw assembly:

$$F_{mbs} = \sqrt[3]{|F_{eff1}|^3 \cdot \frac{|n_1|}{n_m} \cdot \frac{q_{t1}}{100\%} + |F_{eff2}|^3 \cdot \frac{|n_2|}{n_m} \cdot \frac{q_{t2}}{100\%} + |F_{eff3}|^3 \cdot \frac{|n_3|}{n_m} \cdot \frac{q_{t3}}{100\%} + \dots + |F_{effn}|^3 \cdot \frac{|n_n|}{n_m} \cdot \frac{q_{tn}}{100\%}}$$

The following applies to the axial load  $F_n$  for linear motion systems:

$$F_{eff} = |F_n|$$

When both the load and the rotary speed vary, the average load  $F_{mbs}$  is calculated as follows:

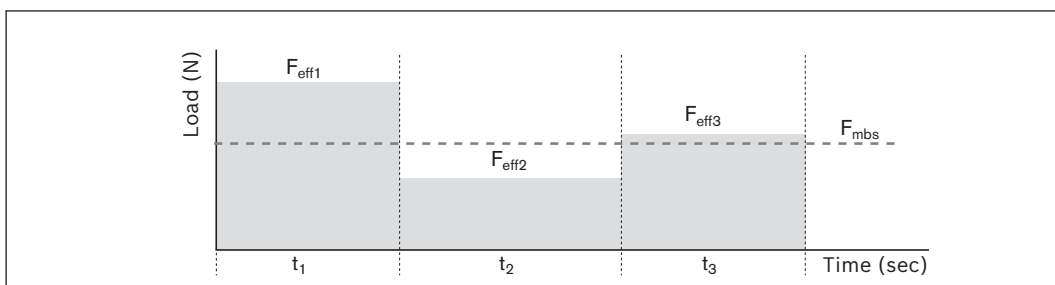

Average rotary speed of the screw:

$$n_m = \frac{|n_1| \cdot q_{t1} + |n_2| \cdot q_{t2} + \dots + |n_n| \cdot q_{tn}}{100\%} = \frac{v_{mgw} \cdot 60\,000}{P}$$

If rotary speed varies, average rotary speed  $n_m$  is calculated as follows:

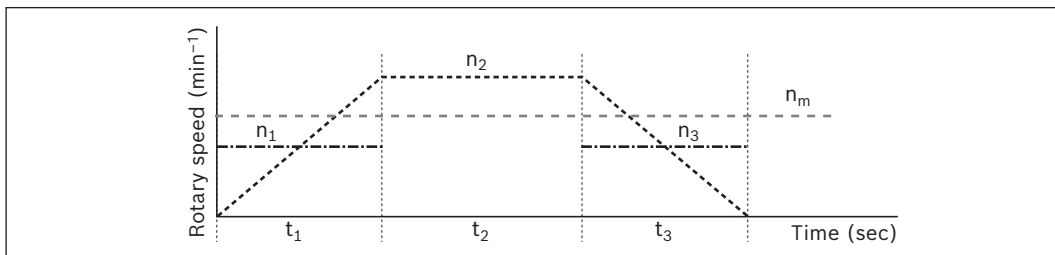

Rotary speed in acceleration and braking phases  $n_1 \dots n_n$ :

$$n_1 \dots n_n = \frac{n_{A1 \dots n} + n_{E1 \dots n}}{2}$$

## Drive sizing

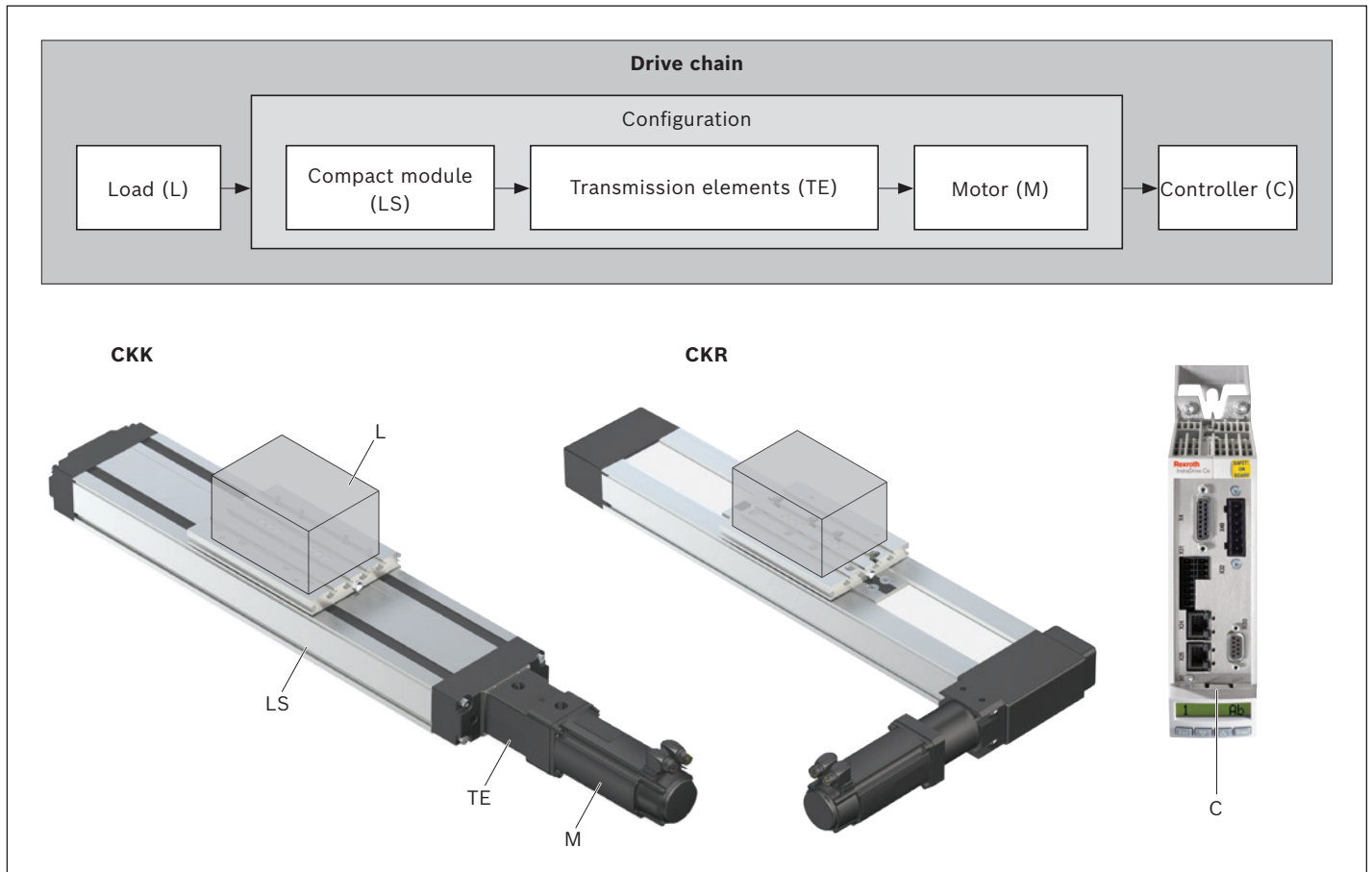

The correct dimensioning and assessment of an application requires structured consideration of the drive chain as a whole.

The basic element of the drive chain is the configuration – made up of the linear motion system, the transmission element (coupling, belt side drive or gear unit) and the motor – which can be ordered in that constellation in the catalog.

### Basic principles

For drive sizing, the drive chain can be divided into mechanical system and drive system.

The **mechanical** system includes the physical components – linear motion system and the transmission elements (belt side drive, coupling) – and the load to be carried.

The electric **drive** is a motor-controller combination with corresponding performance data.

The sizing and/or dimensioning of the electric drive is done taking the motor shaft as a reference point.

For drive sizing, limits must be taken into account as well as base values. The limits must not be exceeded in order to avoid damaging the mechanical components.

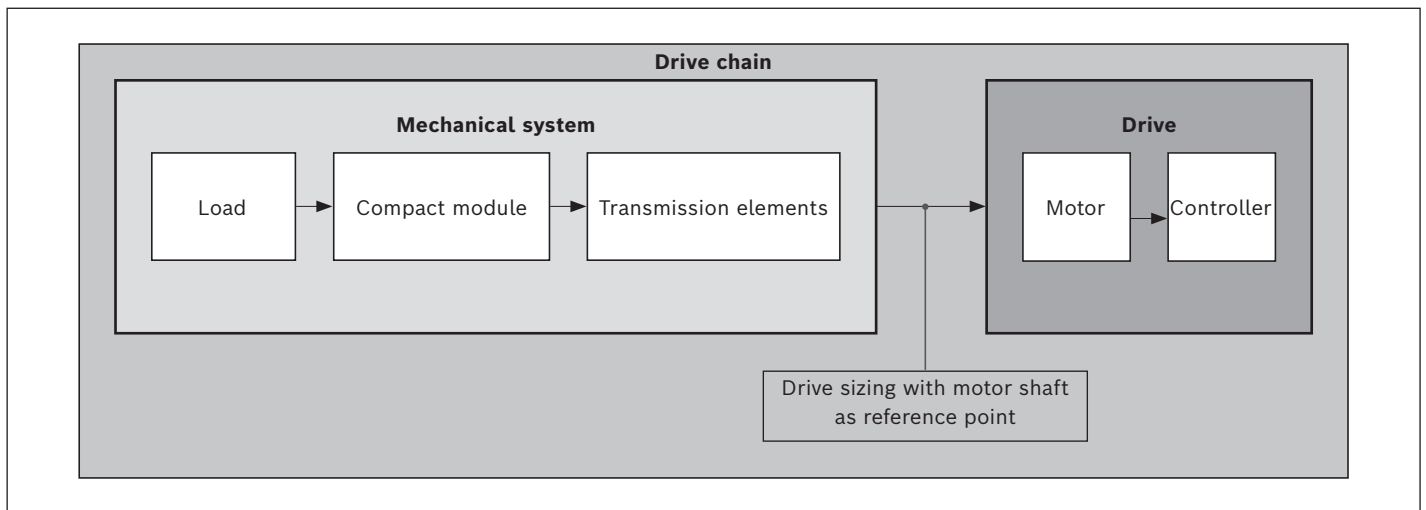

### Technical data and formula symbols for the mechanical system

For every component (linear motion system, coupling, belt side drive, gear unit), the corresponding maximum permissible limits for drive torque and speed, and the base values for friction torque and mass moment of inertia have to be used.

The following technical data with the associated formula symbols are used when considering the basic **mechanical** system requirements in the design calculations for sizing the drive. The data listed in the table below can be found in the chapter "Technical Data" or is determined using formulas based on the descriptions on the following pages.

	Mechanical system					
	Load	Linear motion system	Transmission element			
			Coupling	Belt side drive	Gearing	
<b>Weight moment</b>	(Nm)	$M_g^{5)}$	—	—	—	
<b>Friction torque</b>	(Nm)	$f^{4)}$	$M_{Rs}^{3)}$	—	$M_{Rge}^{3)}$	
<b>Mass moment of inertia</b>	(kgm <sup>2</sup> )	$J_t^{1)}$	$J_s^{2)}$	$J_c^{3)}$	$J_{sd}^{3)}$	$J_{ge}^{3)}$
<b>Max. permissible speed</b>	(m/s)	—	$v_{max}^{3)4)}$	—	—	—
<b>Max. permissible rotary speed</b>	(rpm)	—	$n_p^{1)}$	—	—	$n_{ge}^{3)}$
<b>Max. permissible drive torque</b>	(Nm)	—	$M_p^{3)4)}$	$M_{cN}^{3)}$	$M_{sd}^{3)}$	$M_{ge}^{3)}$

- 1) Determine the value using the appropriate formula
- 2) Length-dependent value, determined using the appropriate formula
- 3) Use the value from the table
- 4) CKK: Length-dependent value, to be read off the graph
- 5) Any additional process forces are to be taken into consideration as load moments
- 6) For vertical installation position: Determine the value using the appropriate formula

### Drive sizing with motor shaft as reference point

When sizing the drive, all relevant design calculation values for the mechanical components in the drive chain have to be determined and be expressed/reduced to the motor shaft. For a combination of mechanical components within the drive chain, this will result in one value for each of the following:

- ▶ Friction torque  $M_R$
- ▶ Mass moment of inertia  $J_{ex}$
- ▶ Max. permissible speed  $v_{mech}$  (maximum permissible rotary speed  $n_{mech}$ )
- ▶ Max. permissible drive torque  $M_{mech}$

### Determination of the values for each mechanical component in the drive chain based on the motor shaft as a reference point

#### Compact modules CKK

##### Friction torque $M_R$

For motor attachment via flange and coupling

$$M_R = M_{Rs}$$

For motor attachment via belt side drive

$$M_R = M_{Rsd} + \frac{M_{Rs}}{i}$$

##### Mass moment of inertia $J_{ex}$

For motor attachment via flange and coupling

$$J_{ex} = J_s + J_t + J_c$$

For motor attachment via belt side drive

$$J_{ex} = J_{sd} + \frac{(J_s + J_t)}{i^2}$$

#### Compact modules CKR

##### Friction torque $M_R$

For motor attachment via gear

$$M_R = M_{Rge} + \frac{M_{Rs}}{i}$$

##### Mass moment of inertia $J_{ex}$

For direct motor attachment (without gear)

$$J_{ex} = J_s + J_t$$

For motor attachment via gear

$$J_{ex} = J_{ge} + \frac{(J_s + J_t)}{i^2}$$

Mass moment of inertia of linear motion system

$$J_s = (k_{J \text{ fix}} + k_{J \text{ var}} \cdot L) \cdot 10^{-6}$$

Determination of translative mass moment of inertia of the external load

$$J_t = m_{ex} \cdot k_{J m} \cdot 10^{-6}$$

**Maximum permissible speed  $v_{\text{mech}}$  or maximum permissible rotary speed  $n_{\text{mech}}$**

The lowest of all the values for permissible speed or rotary speed of all mechanical components contained in the drive chain determines the maximum permissible speed of the mechanical system which has to be taken into consideration as the upper limit for the drive when sizing the motor.

Depending on the system, the maximum permissible speed/rotary speed of the linear motion system with ball screw assembly is always below the limits for the coupling or belt side drive components, meaning it determines the maximum permissible speed of the mechanical system.

**Compact modules CKK**

**Maximum permissible speed**

$$v_{\text{mech}} = v_{\text{max}}$$

**Maximum permissible rotary speed**

For motor attachment via flange and coupling

$$n_{\text{mech}} = \frac{v_{\text{mech}} \cdot 1\,000 \cdot 60}{P}$$

For motor attachment via belt side drive

$$n_{\text{mech}} = \frac{v_{\text{mech}} \cdot i \cdot 1\,000 \cdot 60}{P}$$

**Compact modules CKR**

**Maximum permissible speed**

For direct motor attachment (without gear)

$$v_{\text{mech}} = v_{\text{max}}$$

$$v_{\text{mech}} = \frac{n_{\text{mech}} \cdot \pi \cdot d_3}{1000 \cdot 60}$$

For motor attachment via gear

$$v_{\text{mech}} = \frac{n_{\text{mech}} \cdot \pi \cdot d_3}{i \cdot 1\,000 \cdot 60}$$

**Maximum permissible rotary speed**

For direct motor attachment (without gear)

$$n_{\text{mech}} = \frac{v_{\text{mech}} \cdot 1\,000 \cdot 60}{\pi \cdot d_3}$$

$$n_{\text{mech}} = n_p$$

For motor attachment via gear

$$n_p = \frac{v_{\text{max}} \cdot 1\,000 \cdot 60}{\pi \cdot d_3}$$

$$n_{\text{mech}} = \text{minimum}(n_p \cdot i; n_{ge})$$

### Maximum permissible drive torque $M_{\text{mech}}$

The lowest (minimum) of all the values for permissible drive torque of all mechanical components contained in the drive chain determines the maximum permissible drive torque of the mechanical system which has to be taken into consideration as the upper limit for the drive when sizing the motor.

#### Compact modules CKK

For motor attachment via flange and coupling

$$M_{\text{mech}} = \text{minimum} (M_{\text{cN}}; M_{\text{p}})$$

For motor attachment via belt side drive

$$M_{\text{mech}} = \text{minimum} (M_{\text{sd}}; \frac{M_{\text{p}}}{i})$$

#### Compact modules CKR

For direct motor attachment (without gear)

$$M_{\text{mech}} = M_{\text{p}}$$

For motor attachment via gear

$$M_{\text{mech}} = \text{minimum} (\frac{M_{\text{ge}}}{i}; \frac{M_{\text{p}}}{i})$$

**⚠** When considering the complete drive chain (mechanical system + motor/controller), the maximum torque of the motor can lie below the upper limit for the mechanical system ( $M_{\text{mech}}$ ) and thus limit the maximum permissible drive torque of the overall drive chain.

If the maximum torque of the motor lies above the upper limit for the mechanical system ( $M_{\text{mech}}$ ), the maximum motor torque must be limited to the permissible value for the mechanical system.

### General motor preselection

The motor can be generally preselected using the following conditions.

#### Condition 1:

The rotary speed of the motor must be greater than or equal to the rotary speed required for the mechanical system (but not exceeding the maximum permissible limit value).

$$n_{\text{max}} \geq n_{\text{mech}}$$

**Condition 2:**

Consideration of the ratio of mass moments of inertia of the mechanical system and the motor. The ratio of the mass moments of inertia serves as an indicator for the control performance of a motor-controller combination.

The mass moment of inertia of the motor is directly related to the motor size.

Ratio of mass moments of inertia

For preselection, experience has shown that the following ratios will result in high control performance. These are not rigid limits, but values exceeding them will require closer consideration of the specific application.

Application area	V
Handling	≤ 6.0
Machining	≤ 1.5

$$V = \frac{J_{ex}}{J_m + J_{br}}$$

**Condition 3:**

Estimation of the ratio of the static load moment to the continuous torque of the motor. The torque ratio must be less than or equal to an empirical value of 0.6. This condition roughly factors in the missing dynamic characteristics of an exact motion profile with the required motor torques.

Torque ratio

$$\frac{M_{stat}}{M_0} \leq 0.6$$

Static load moment

$$M_{stat} = M_R + M_g$$

**Compact modules CKK**

Weight moment

For vertical installation position only!

For motor attachment via flange and coupling:  $i = 1$

$$M_g = \frac{P \cdot (m_{ex} + m_{ca}) \cdot g}{2\,000 \cdot \pi \cdot i}$$

**Compact modules CKR**

Weight moment For vertical installation position only!

$$M_g = \frac{d_3 \cdot (m_{ex} + m_{ca}) \cdot g}{2\,000 \cdot i}$$

In the chapter titled ➡ "Configuration and ordering", users can put together standard configurations, including motor attachment, gears and motor, for the various linear motion system sizes by selecting the appropriate options. By checking the above conditions, it is possible to see whether a standard motor selected in a particular configuration will generally be of a suitable size for the specific application.

**Precise drive sizing**

Preselecting the motor according to this rough guide is no substitute for the required precise design calculations for the drive, taking all moments/torques and rotary speed levels into account. For precise calculation of the electric drive, including consideration of the specific motion profile, please refer to the performance data in the catalog "Rexroth drive technology". When sizing the drive, the maximum permitted values for linear speed, drive torque and acceleration must not be exceeded, in order to avoid damaging the mechanical system.

### Calculation example CKK

#### Given data

In a handling task, a mass of 30 kg is to be moved horizontally by 500 mm at a travel speed of 0.5 m/s. The following was selected based on the technical data and the installation space:

#### Compact module CKK-110

- ▶ Carriage with connection plate  
 $L_{ca} = 155 \text{ mm}$
- ▶ With cover strip
- ▶ Motor attachment via belt side drive,  
 $i = 1.5$
- ▶ With motor MS2N04-B0BTN with brake

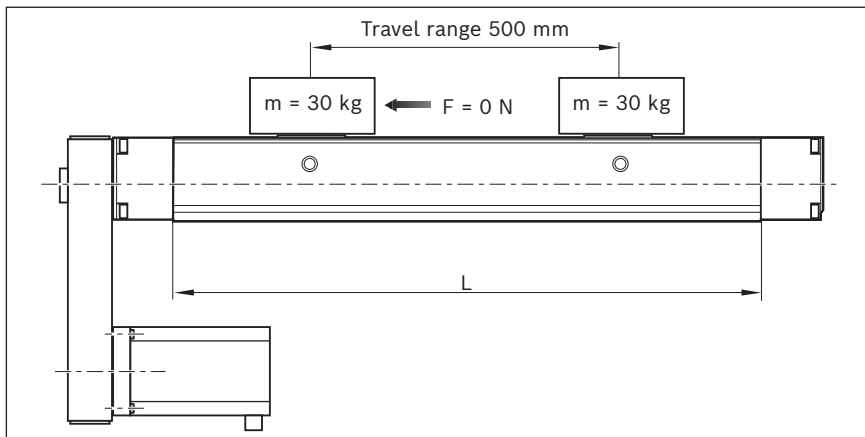

#### Estimation of length L

(For an initial estimate, the greatest possible lead and length are used for the calculation since the permissible speed can decrease as length increases.)

	$L = s_{eff} + 2 \cdot s_e + L_{ca} + L_{ad}$
Excess travel:	$s_e = 2 \cdot P = 2 \cdot 16 = 32 \text{ mm}$
Max. travel range:	$s_{max} = s_{eff} + 2 \cdot s_e$
	$= 500 + 2 \cdot 32 = 564 \text{ mm}$
Length:	$L = 564 + 155 + 20 = 739 \text{ mm}$

#### Selection of the ball screw assembly

(Better to choose the lowest lead as this is favorable in terms of resolution, braking distance, length.)

Permissible ball screw assemblies according to "Permissible speed" graph with given  $v = 0.5 \text{ m/s}$  and  $L = 739 \text{ mm}$ :

BASA 16 x 10 and BASA 16 x 16

Selected ball screw assembly (lower lead):

BASA 16 x 10

Maximum permissible speed for BASA 16 x 10 from graph:

$$v_{max} = 0.77 \text{ m/s}$$

#### Calculation of length L

(for selected ball screw assembly)

Excess travel:	$s_e = 2 \cdot P = 2 \cdot 10 = 20 \text{ mm}$
Max. travel range:	$s_{max} = s_{eff} + 2 \cdot s_e$
	$= 500 + 2 \cdot 20 = 540 \text{ mm}$
Length:	$L = 540 + 155 + 20 = 715 \text{ mm}$

#### Friction moment $M_R$

(motor attachment via belt side drive)

	$M_R = M_{Rsd} + \frac{M_{Rs}}{i}$
Compact module:	$M_{Rs} = 0.43 \text{ Nm}$
Belt side drive:	$M_{Rsd} = 0.40 \text{ Nm} (i = 1.5)$
Friction torque:	$M_R = 0.40 + \frac{0.43}{1.5} = 0.69 \text{ Nm}$



**Mass moment of inertia  $J_{ex}$**

(motor attachment via belt side drive)

$$J_{ex} = J_{sd} + \frac{(J_s + J_t)}{i^2}$$

Belt side drive:  $J_{sd} = 82 \cdot 10^{-6} \text{ kgm}^2$

Compact module:  $J_s = (k_{J \text{ fix}} + k_{J \text{ var}} \cdot L) \cdot 10^{-6}$   
 $= (8.432 + 0.031 \cdot 715) \cdot 10^{-6}$   
 $= 30.597 \cdot 10^{-6} \text{ kgm}^2$

External load:  $J_t = m_{ex} \cdot k_{J m} \cdot 10^{-6}$   
 $= 30 \cdot 2.533 \cdot 10^{-6}$   
 $= 75.99 \cdot 10^{-6} \text{ kgm}^2$

Mass moment of inertia:  $J_{ex} = 82 \cdot 10^{-6} + \frac{(30.597 \cdot 10^{-6} + 75.99 \cdot 10^{-6})}{1.5^2}$   
 $= 129.372 \cdot 10^{-6} \text{ kgm}^2$

**Maximum permissible rotary speed  $n_{mech}$**

(motor attachment via belt side drive)  
 mechanical system limit

$$n_{mech} = \frac{(0.77 \cdot 1.5 \cdot 1\,000 \cdot 60)}{10}$$

Max. permissible speed:  $v_{mech} = v_{max} = 0.77 \text{ m/s}$

$$n_{mech} = \frac{(v_{mech} \cdot i \cdot 1,000 \cdot 60)}{P}$$

Max. permissible rotary speed:  $n_{mech} = 6\,930 \text{ min}^{-1}$

**Maximum rotary speed of the application  $n_{mech}$**

(motor attachment via belt side drive)  
 application limit

Speed:  $v_{mech} = 0.5 \text{ m/s}$

Rotary speed:  $n_{mech} = \frac{0.5 \cdot 1.5 \cdot 1\,000 \cdot 60}{10}$   
 $= 4\,500 \text{ min}^{-1}$

### Calculation example CKK

#### Maximum permissible

#### drive torque $M_{\text{mech}}$

(motor attachment via belt side drive)  
mechanical system limit

$$M_{\text{mech}} = \text{Minimum} \left( M_{\text{sd}}; \frac{M_{\text{p}}}{i} \right)$$

Belt side drive:  $M_{\text{sd}} = 5.11 \text{ Nm}$  (gear ratio  $i = 1.5$  for MS2N04-B0BTN)

Compact module:  $M_{\text{p}} = 13.51 \text{ Nm}$

Drive torque:  $M_{\text{mech}} = \text{Minimum} \left( 5.11; \frac{13.51}{1.5} \right)$   
 $= \text{Minimum} (5.11; 9.0)$   
 $= 5.11 \text{ Nm}$

#### Motor preselection check

Selected motor:

MS2N04-B0BTN with brake

#### Condition 1:

Rotary speed:  $n_{\text{max}} \geq n_{\text{mech}}$   
 $6,000 \geq 4500$  condition met – motor selection OK

#### Condition 2:

Mass moment of inertia ratio:  $V = \frac{J_{\text{ex}}}{J_{\text{m}} + J_{\text{br}}}$

Motor inertia:  $J_{\text{m}} = 70 \cdot 10^{-6} \text{ kgm}^2$

Brake moment of inertia:  $J_{\text{br}} = 40 \cdot 10^{-6} \text{ kgm}^2$

Moment of inertia ratio:  $V = \frac{129.372 \cdot 10^{-6}}{(70 \cdot 10^{-6} + 40 \cdot 10^{-6})} = 1.18$

Handling condition:  $V \leq 6$   
 $1.18 \leq 6$  condition met  
 – motor selection OK

#### Condition 3:

Torque ratio:  $\frac{M_{\text{stat}}}{M_0} \leq 0.6$

Static load moment:  $M_{\text{stat}} = M_{\text{R}} + M_{\text{g}}$  (installed horizontally  $M_{\text{g}} = 0$ )  
 $= 0.69 \text{ Nm}$

Continuous motor torque:  $M_0 = 1.75 \text{ Nm}$

Torque ratio:  $\frac{0.69}{1.75} = 0.39$   
 $0.39 \leq 0.6$  condition met  
 – motor selection OK

**All three conditions met ⇒ Selected motor is suitable for the application.**

**Result**

**Compact module CKK-110**

Length:  $L = 715 \text{ mm}$   
 Max. travel range:  $s_{\max} = 540 \text{ mm}$   
 Carriage length:  $L_{ca} = 155 \text{ mm}$   
 Ball screw assembly: Nominal diameter:  $d_0 = 16 \text{ mm}$   
 Lead:  $P = 10 \text{ mm}$

With cover strip  
 Motor attachment via belt side drive, gear ratio  $i = 1.5$   
 Motor preselection: MS2N04-B0BTN with brake

For precise sizing of the electric drive, the motor-controller combination must always be considered, as the performance data (e.g. maximum useful speed and maximum torque) will depend on the controller used.

When doing this, the following data must be considered:

Friction torque:  $M_R = 0.69 \text{ Nm}$   
 Mass moment of inertia:  $J_{ex} = 129.372 \cdot 10^{-6} \text{ kgm}^2$   
 Speed:  $v_{\text{mech}} = 0.5 \text{ m/s}$  ( $n_{\text{mech}} = 4\,500 \text{ rpm}$ )  
 Drive torque limit:  $M_{\text{mech}} = 5.11 \text{ Nm}$

⇒ The motor torque must be limited to 5.11 Nm on the drive side!

Acceleration limit:  $a_{\max} = 50 \text{ m/s}^2$   
 Limit for speed:  $v_{\max} = 0.77 \text{ m/s}$  ( $n_{\text{mech}} = 6\,930 \text{ rpm}$ )

Besides the preferred type MS2N04-B0BTN, other motors with identical connection dimensions can be adapted while taking care not to exceed the calculated limit values.

### Calculation example CKR

#### Given data

In a handling task, a mass of 25 kg is to be moved horizontally by 1000 mm at a travel speed of 1.5 m/s. The following was selected based on the technical data and the installation space:

#### compact module CKR-145

- ▶ Carriage length = 190 mm
- ▶ With connection plate
- ▶ Motor attachment via planetary gear,  $i = 5$
- ▶ With motor MS2N04-D0BQN without brake

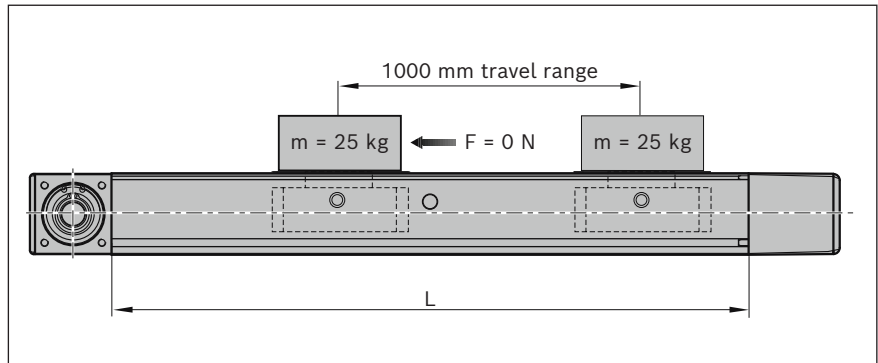

#### Calculation of length L

(In most cases, 2x feed constant is sufficient as general guideline value for excess travel. The excess travel must be greater than the emergency stop stopping distance, which is calculated for exact sizing of the electrical drive.)

$$\begin{aligned}
 L &= s_{\max} + L_{ca} + L_{ad} \\
 \text{Feed constant: } u &= \frac{u(i=1)}{i} \\
 &= \frac{165}{5} = 33 \text{ mm} \\
 \text{Excess travel: } s_e &= 2 \cdot u = 2 \cdot 33 = 66 \text{ mm} \\
 \text{Max. travel range: } s_{\max} &= s_{\text{eff}} + 2 \cdot s_e \\
 &= 1\,000 + 2 \cdot 66 = 1132 \text{ mm} \\
 \text{Length: } L &= 1\,132 + 190 + 75 = 1397 \text{ mm}
 \end{aligned}$$

#### Friction torque $M_R$

$$\begin{aligned}
 M_R &= M_{Rge} + \frac{M_{RS}}{i} \\
 \text{Compact module: } M_{RS} &= 2.04 \text{ Nm} \\
 \text{Gear: } M_{Rge} &= 0.17 \text{ Nm} \\
 \text{Friction torque: } M_R &= 0.17 + \frac{2.04}{5} = 0.58 \text{ Nm}
 \end{aligned}$$

#### Mass moment of inertia $J_{ex}$

$$\begin{aligned}
 J_{ex} &= J_{ge} + \frac{(J_s + J_t)}{i^2} \\
 \text{Gear: } J_{ge} &= 27 \cdot 10^{-6} \\
 \text{Compact module: } J_s &= (k_{J \text{ fix}} + k_{J \text{ var}} \cdot L) \cdot 10^{-6} \\
 &= (2\,276.71 + 0.3172 \cdot 1397) \cdot 10^{-6} \\
 &= 2\,719.838 \cdot 10^{-6} \text{ kgm}^2 \\
 \text{External load: } J_t &= m_{ex} \cdot k_{Jm} \cdot 10^{-6} \\
 &= 25 \cdot 689.59 \cdot 10^{-6} \\
 &= 17\,239.75 \cdot 10^{-6} \text{ kgm}^2 \\
 \text{Mass moment of inertia: } J_{ex} &= 27 \cdot 10^{-6} + \frac{(2\,719.838 \cdot 10^{-6} + 17\,239.75 \cdot 10^{-6})}{5^2} \\
 &= 825.384 \cdot 10^{-6} \text{ kgm}^2
 \end{aligned}$$

**Maximum permissible rotary speed  $n_{\text{mech}}$**

(Motor attachment via gear reducer,  
without considering the motor)

Limit for mechanical system

$$\begin{aligned}
 n_{\text{mech}} &= \text{Minimum} (n_p \cdot i ; n_{\text{ge}}) \\
 \text{Compact module: } n_p &= \frac{(v_{\text{max}} \cdot 1\,000 \cdot 60)}{\pi \cdot d_3} \\
 &= \frac{(5 \cdot 1\,000 \cdot 60)}{\pi \cdot 52.52} \\
 &= 1\,818 \text{ rpm} \\
 \text{Gear: } n_{\text{ge}} &= 8\,000 \text{ rpm} \\
 \text{Max. permissible rotary speed: } n_{\text{mech}} &= \text{Minimum} (1\,818 \cdot 5 ; 8\,000) \\
 &= \text{Minimum} (9\,090 ; 8\,000) \\
 &= 8\,000 \text{ rpm}
 \end{aligned}$$

**Maximum permissible speed  $v_{\text{mech}}$**

(Motor attachment via gear reducer,  
without considering the motor)

Limit for mechanical system

$$\begin{aligned}
 v_{\text{mech}} &= \frac{(n_{\text{mech}} \cdot \pi \cdot d_3)}{i \cdot 1\,000 \cdot 60} \\
 \text{Max. permissible speed: } v_{\text{mech}} &= \frac{(8\,000 \cdot \pi \cdot 52.52)}{5 \cdot 1\,000 \cdot 60} \\
 &= 4.4 \text{ m/s}
 \end{aligned}$$

**Maximum permitted rotary speed of the application  $n_{\text{mech}}$**

(Motor attachment via gear reducer,  
without considering the motor)

Application tolerance

$$\begin{aligned}
 \text{Speed: } v_{\text{mech}} &= 1.5 \text{ m/s} \\
 \text{Rotary speed: } n_{\text{mech}} &= \frac{(1.5 \cdot 5 \cdot 1\,000 \cdot 60)}{\pi \cdot 52.52} \\
 &= 2\,727 \text{ rpm}
 \end{aligned}$$

**Maximum permissible drive torque  $M_{\text{mech}}$**

(Motor attachment via gear reducer,  
without considering the motor)

Limit for mechanical system

$$\begin{aligned}
 M_{\text{mech}} &= \text{Minimum} \left( \frac{M_{\text{ge}}}{i} ; \frac{M_p}{i} \right) \\
 \text{Compact module: } M_p &= 32.5 \text{ Nm} \\
 \text{Gear: } M_{\text{ge}} &= 40 \text{ Nm} \\
 \text{Drive torque: } M_{\text{mech}} &= \text{Minimum} \left( \frac{40}{5} ; \frac{32.5}{5} \right) \\
 &= \text{Minimum} (8.0 ; 6.5) \\
 &= 6.5 \text{ Nm}
 \end{aligned}$$

**Calculation example CKR**

**Motor preselection check**

Selected motor:  
 MS2N04-D0BQN without brake

**Condition 1:**  
 Rotary speed:  $n_{\max} \geq n_{\text{mech}}$   
 $6,000 \geq 2727$  condition met – motor selection OK

**Condition 2:**  
 Mass moment of inertia ratio:  $V = \frac{J_{\text{ex}}}{J_m + J_{\text{br}}}$   
 Motor inertia:  $J_m = 160 \cdot 10^{-6} \text{ kgm}^2$   
 Brake moment of inertia:  $J_{\text{br}} = 0 \text{ kgm}^2$  (without brake)  
 Moment of inertia ratio:  $V = \frac{825.384 \cdot 10^{-6}}{160 \cdot 10^{-6}}$   
 $= 5.16$   
 Handling condition:  $V \leq 6$   
 $5.16 \leq 6$  condition met  
 – motor selection OK

**Condition 3:**  
 Torque ratio:  $\frac{M_{\text{stat}}}{M_0} \leq 0.6$   
 Static load moment:  $M_{\text{stat}} = M_R + M_g$  (installed horizontally  $M_g = 0$ )  
 $\frac{0.58}{3.85} = 0.58 \text{ Nm}$   
 Continuous torque  
 of the motor:  $M_0 = 3.85 \text{ Nm}$   
 Torque ratio:  $= 0.15$   
 $0.15 \leq 0.6$  condition met  
 – motor selection OK

**All three conditions met  $\Rightarrow$  selected motor is suitable for the application.**

**Result**

**compact module CKR-145**

Length  $L = 1\,397\text{ mm}$

Max. travel range  $s_{\max} = 1\,132\text{ mm}$

Carriage length  $L_{\text{ca}} = 190\text{ mm}$

Toothed belt drive

With connection plate

Motor attachment via planetary gear, gear ratio  $i = 5$

Motor preselection: MS2N04-D0BQN without brake

For precise sizing of the electric drive, the motor-controller combination must always be considered, as the performance data (for example, maximum useful speed and maximum torque) will depend on the controller used.

When doing this, the following data must be considered.

Friction torque  $M_R = 0.58\text{ Nm}$

Mass moment of inertia  $J_{\text{ex}} = 825.384 \cdot 10^{-6}\text{ kgm}^2$

Travel speed  $v_{\text{mech}} = 1.5\text{ m/s}$  ( $n_{\text{mech}} = 2\,727\text{ min}^{-1}$ )

Drive torque limit  $M_{\text{mech}} = 6.5\text{ Nm}$

➡ The motor torque must be limited to 6.5 Nm on the drive side!

Acceleration limit  $a_{\max} = 50\text{ m/s}^2$

Limit for travel speed  $v_{\max} = 3.3\text{ m/s}$  ( $n_{\max} = 6\,000\text{ min}^{-1}$ )

After determining the emergency-stop stopping distance during precise sizing, the selected excess travel must be checked to see whether it is sufficient and adjusted if necessary.

Besides the preferred type MS2N04-D0BQ, other motors with identical connection dimension can be adapted while taking care not to exceed the calculated limits.

## Abbreviations

Abbreviation/ index	Designation	Unit
<b>a</b>	Acceleration	(m/s <sup>2</sup> )
<b>a<sub>max</sub></b>	Maximum acceleration rate	(m/s <sup>2</sup> )
<b>BASA</b>	Ball screw assembly	(–)
<b>B<sub>t</sub></b>	Belt type	(–)
<b>c<sub>spe</sub></b>	Specific spring rate	(N)
<b>C<sub>gw</sub></b>	Dynamic load capacity, guideway	(N)
<b>C<sub>bs</sub></b>	Dynamic load capacity, ball screw assembly	(N)
<b>C<sub>fb</sub></b>	Dynamic load capacity, fixed bearing	(N)
<b>d<sub>0</sub></b>	Nominal diameter, ball screw assembly	(mm)
<b>d<sub>3</sub></b>	Belt pulley diameter	(mm)
<b>f<sub>w</sub></b>	Load factor	(–)
<b>F<sub>n</sub></b>	Axial load of the ball screw assembly	(N)
<b>F<sub>eff</sub></b>	Effective equivalent axial load	(N)
<b>F<sub>bp</sub></b>	Max. belt drive transmission force	(N)
<b>F<sub>comb</sub></b>	Combined equivalent bearing load	(N)
<b>F<sub>mbs</sub></b>	Dynamically equivalent load on bearing of the ball screw assembly	(N)
<b>F<sub>mgw</sub></b>	Dynamically equivalent load on bearing of the guideway	(N)
<b>F<sub>n</sub></b>	Axial load of the ball screw assembly	(N)
<b>F<sub>t zul</sub></b>	Belt elasticity limit	(N)
<b>F<sub>y</sub></b>	Load due to a resulting force in the y-direction	(N)
<b>F<sub>y max</sub></b>	Maximum dynamic load in y-direction	(N)
<b>F<sub>z</sub></b>	Load due to a resulting force in the z-direction	(N)
<b>F<sub>z max</sub></b>	Maximum dynamic load in z-direction	(N)
<b>g</b>	Gravitational acceleration (= 9.81)	(m/s <sup>2</sup> )
<b>i</b>	Gear ratio	(–)
<b>I<sub>y</sub></b>	Planar moment of inertia about the y-axis	(cm <sup>4</sup> )
<b>I<sub>z</sub></b>	Planar moment of inertia about the z-axis	(cm <sup>4</sup> )
<b>J<sub>br</sub></b>	Mass moment of inertia of the motor brake	(kgm <sup>2</sup> )
<b>J<sub>c</sub></b>	Mass moment of inertia of the coupling	(kgm <sup>2</sup> )
<b>J<sub>dc</sub></b>	Mass moment of inertia of the drive train	(kgm <sup>2</sup> )
<b>J<sub>ex</sub></b>	Mass moment of inertia of the mechanical system	(kgm <sup>2</sup> )
<b>J<sub>ge</sub></b>	Mass moment of inertia of the gear about the motor journal	(kgm <sup>2</sup> )
<b>J<sub>m</sub></b>	Mass moment of inertia of the motor	(kgm <sup>2</sup> )
<b>J<sub>s</sub></b>	Mass moment of inertia of the linear motion system	(kgm <sup>2</sup> )
<b>J<sub>sd</sub></b>	Mass moment of inertia of the belt side drive about the motor journal	(kgm <sup>2</sup> )
<b>J<sub>t</sub></b>	Translative mass moment of inertia of external load based on the linear motion system screw journal	(kgm <sup>2</sup> )
<b>k<sub>g fix</sub></b>	Constant for fixed portion of mass	(kg)
<b>k<sub>g var</sub></b>	Constant for variable-length portion of mass	(kg/mm)

Abbreviation/ index	Designation	Unit
<b>k<sub>J fix</sub></b>	Constant for fixed portion of mass moment of inertia	(kg/mm <sup>2</sup> )
<b>k<sub>J m</sub></b>	Constant for mass-specific portion of mass moment of inertia	(mm <sup>2</sup> )
<b>k<sub>J var</sub></b>	Constant for variable-length portion of mass moment of inertia	(kg/mm)
<b>L</b>	Length of the linear motion system	(mm)
<b>L<sub>ad</sub></b>	Additional length	(mm)
<b>L<sub>ca</sub></b>	Carriage length	(mm)
<b>L<sub>bs</sub></b>	Nominal service life (ball screw assembly, fixed bearing)	(rpm)
<b>L<sub>hbs</sub></b>	Nominal service life (ball screw assembly, fixed bearing)	(h)
<b>L<sub>gw</sub></b>	Nominal service life of the guideway	(m)
<b>L<sub>hgw</sub></b>	Nominal service life of the guideway	(h)
<b>L<sub>m</sub></b>	Length of the motor	(mm)
<b>L<sub>max</sub></b>	Max. length	(mm)
<b>L<sub>w</sub></b>	Centerline-to-centerline distance between carriages	(mm)
<b>m<sub>br</sub></b>	Holding brake mass	(kg)
<b>m<sub>ca</sub></b>	Moved mass of system of carriage	(kg)
<b>m<sub>ex</sub></b>	Moved external load	(kg)
<b>m<sub>fc</sub></b>	Mass of flange and coupling	(kg)
<b>m<sub>m</sub></b>	Mass of the motor	(kg)
<b>m<sub>s</sub></b>	Mass of the linear system (without attachments)	(kg)
<b>m<sub>sd</sub></b>	Mass of the timing belt side drive	(kg)
<b>M<sub>0</sub></b>	Continuous motor torque	(Nm)
<b>M<sub>cN</sub></b>	Rated torque of coupling	(Nm)
<b>M<sub>g</sub></b>	Weight moment at motor journal	(Nm)
<b>M<sub>ge</sub></b>	Maximum permissible acceleration torque of the gear (at the output drive)	(Nm)
<b>M<sub>L</sub></b>	Dynamic longitudinal moment load capacity	(Nm)
<b>M<sub>m</sub></b>	Equivalent dynamic torque	(Nm)
<b>M<sub>max</sub></b>	Max. possible motor torque	(Nm)
<b>M<sub>mech</sub></b>	Maximum permissible drive torque for mechanical system	(Nm)
<b>M<sub>p</sub></b>	Maximum permissible drive torque (at drive journal)	(Nm)
<b>M<sub>R</sub></b>	Frictional torque at motor journal	(Nm)
<b>M<sub>Rge</sub></b>	Friction torque of gear at motor journal	(Nm)
<b>M<sub>Rs</sub></b>	Friction torque of system	(Nm)
<b>M<sub>Rsd</sub></b>	Friction torque of belt side drive at motor journal	(Nm)
<b>M<sub>sd</sub></b>	Maximum permissible drive torque of the belt side drive	(Nm)
<b>M<sub>stat</sub></b>	Static load moment	(Nm)
<b>M<sub>t</sub></b>	Dynamic torsional moment load capacity	(Nm)
<b>M<sub>x</sub></b>	Dynamic torsional moment around the x-axis	(Nm)
<b>M<sub>x max</sub></b>	Maximum permissible torsional moment around the x-axis	(Nm)



Abbreviation/ index	Designation	Unit
$M_y$	Dynamic torsional moment around the y-axis	(Nm)
$M_{y \max}$	Maximum permissible torsional moment around the y-axis	(Nm)
$M_z$	Dynamic torsional moment around the z-axis	(Nm)
$M_{z \max}$	Maximum permissible torsional moment around the z-axis	(Nm)
$n$	Rotary speed of the ball screw assembly	(rpm)
$n_1, n_2, \dots, n_n$	Rotary speed in acceleration and braking phases	(rpm)
$n_{A1 \dots n}$	Starting speed in phase 1 ... n	(rpm)
$n_{E1 \dots n}$	Ending speed in phase 1 ... n	(rpm)
$n_{ge}$	Maximum permissible rotary speed of the gear	(rpm)
$n_m$	Average rotary speed of the ball screw assembly	(rpm)
$n_{mech}$	Maximum permissible rotary speed for mechanical system	(rpm)
$n_{max}$	Max. motor speed	(rpm)
$n_p$	Maximum permissible rotary speed of the linear motion system	(rpm)
$P$	Screw lead	(mm)
$P_{app}$	Effective power in application	(W)
Keyway	Keyway	(–)
$q_{t1..n}$	Time step of the phases	(%)
$s_a$	Acceleration travel	(mm)
$s_e$	Excess travel (excess travel $s_e$ should be greater than braking distance. The acceleration travel can be assumed as the guideline value for the braking distance.)	(mm)
$s_{eff}$	Effective stroke	(mm)
$s_{min}$	Minimum travel range	(mm)
$s_{max}$	Maximum travel	(mm)
<b>SPU</b>	Screw support	
$t_a$	Acceleration/braking time	(s)
$t_1, t_2, \dots, t_n$	Time for phase 1 ... n	(s)
$u$	Feed constant	(mm/rev)
$v_1, v_2, \dots, v_n$	Speed in phase 1 ... n	(m/s)
$v_{max}$	Maximum permissible speed	(m/s)
$v_{mech}$	Maximum permissible speed of mechanical system	(m/s)
$v_{mgw}$	Average linear speed of the guideway	(m/s)
$V$	Ratio of mass moments of inertia of drive chain and motor	(–)
$z_1$	Application point of the effective force	(mm)

## Ordering example CKK

Ordering data		Explanation
Compact module	CKK-110-NN-1	Compact module with ball screw assembly CKK-110-NN-1
Length L	715	Length = 715 mm
Version	RV01	Belt side drive
Guideway	01	Standard main body
Lubrication <sup>1)</sup>	LSS	Standard lubrication
<b>Drive</b>		
BASA (ball screw assembly d <sub>0</sub> x P)	02	Nominal diameter = 16 mm, lead = 10 mm
<b>Carriage</b>		
Carriage <sup>2)</sup>	41	Carriage with connection plate, L <sub>ca</sub> = 155 mm
Carriage centerline-to-centerline distance L <sub>w</sub>	–	Only necessary with carriages with variable center-to-center distance
<b>Motor attachment</b>		
Gear ratio	–	Without gear ratio
Attachment kit <sup>3)</sup>	23	Motor attachment for MS2N04-C0BTN servo motor
<b>Motor</b>		
Motor code	212	MS2N04-B0BTN, 1 cable, with brake
Motor connector position	270	Motor connector position = 270°
<b>Cover</b>		
Cover	02	With cover strip
<b>Switching system (max. 6 switches/sensors selectable)</b>		
Sensor 1	21	REED, changeover contact (NC: C+NC, NO: C+NO)
Sensor 2	22	Hall, PNP normally closed (NC)
Sensor 3	21	REED, changeover contact (NC: C+NC, NO: C+NO)
Cable duct / cable channel	25	Cable duct
Socket-connector	17	Socket-connector
Documentation	01	Standard report

<sup>1)</sup> Not part of the option key

<sup>2)</sup> For the permissible values see "General technical data"

<sup>3)</sup> The motor geometry code is required for motors according to customer specifications

# Inquiry/order form for CKK

Ordering data		Explanation
Compact module		
Length L		
Version		
Guideway		
Lubrication <sup>1)</sup>		
<b>Drive</b>		
BASA (ball screw assembly d <sub>0</sub> x P)		
<b>Carriage</b>		
Carriage <sup>2)</sup>		
Carriage centerline-to-centerline distance L <sub>w</sub>		
<b>Motor attachment</b>		
Gear ratio		
Attachment kit <sup>3)</sup>		
<b>Motor</b>		
Motor code		
Motor connector position		
<b>Cover</b>		
Cover		
<b>Switching system</b>		
Sensor 1		
Sensor 2		
Sensor 3		
Cable duct / cable channel		
Socket-connector		
<b>Documentation</b>		

- <sup>1)</sup> Not part of the option key
- <sup>2)</sup> For the permissible values see "General technical data"
- <sup>3)</sup> The motor geometry code is required for motors according to customer specifications

### Motor attachment kits according to customer specification (motor geometry code)

The dimensions queried result in a unique "motor geometry code":

□□ - □□ - □□□□ - □□□□ - □□□□ - **M**□□□ - □□□□ - □□□□

- ∅D** = Shaft diameter
- C** = Shaft length
- ∅E** = Centering diameter
- C<sub>1</sub>** = Centering depth
- ∅F** = Pitch diameter
- ∅G** = Drill hole for fastening screw (specify thread diameter)
- B<sub>1</sub>** = Flange thickness
- A** = Flange edge dimension

**Quantity** Acceptance of: \_\_\_\_ pcs, \_\_\_\_ per month, \_\_\_\_ per year, per order, or

Comments: \_\_\_\_\_

**From**  
 Company: \_\_\_\_\_ Name: \_\_\_\_\_  
 Address: \_\_\_\_\_ Department: \_\_\_\_\_  
 \_\_\_\_\_ Phone: \_\_\_\_\_  
 \_\_\_\_\_ Fax: \_\_\_\_\_

## Ordering example CKR

Ordering data		Explanation
Compact module	CKR-110-NN-1	Compact module with toothed belt drive CKR-110-NN-1
Length L	1500	Length = 1500 mm
Version	MG10	Gear attachment right
Guideway	01	Standard main body
<b>Drive</b>		
Toothed belt drive	08	Toothed belt drive, with attachment kit for gearbox and second journal
Lubrication <sup>1)</sup>	LSS	Standard lubrication
<b>Carriage</b>		
Carriage <sup>2)</sup>	41	Carriage with connection plate, $L_{ca} = 155$ mm
<b>Motor attachment</b>		
Gearing	23	Gearing PG050, $i=5$ for motor MS2N04
<b>Motor</b>		
Motor code	212	MS2N04-B0BTN, 1 cable connection, with brake
Motor connector position	090	Motor connector position = 90°
<b>Switching system (max. 6 switches/sensors selectable)</b>		
Sensor 1	21	REED, changeover contact (NC: C+NC, NO: C+NO)
Sensor 2	22	Hall, PNP normally closed (NC)
Sensor 3	21	REED, changeover contact (NC: C+NC, NO: C+NO)
Cable duct / cable channel	25	Cable duct
Socket-connector	17	Socket-connector
Documentation	01	Standard report

<sup>1)</sup> Not part of the option key

<sup>2)</sup> For the permissible values see "General technical data"

# Inquiry/order form for CKR

Ordering data		Explanation
Compact module		
Length L		
Version		
Guideway		
Drive		
Toothed belt drive		
Lubrication <sup>1)</sup>		
Carriage		
Carriage <sup>2)</sup>		
Motor attachment		
Gearing		
Motor		
Motor code		
Motor connector position		
Switching system (max. 6 switches/sensors selectable)		
Sensor 1		
Sensor 2		
Sensor 3		
Cable duct / cable channel		
Socket-connector		
Documentation		

<sup>1)</sup> Not part of the option key





<sup>2)</sup> For the permissible values see "General technical data"

**Quantity** Acceptance of: \_\_\_\_ pcs, \_\_\_\_ per month, \_\_\_\_ per year, per order, or

Comments: \_\_\_\_\_

**From**  
 Company: \_\_\_\_\_ Name: \_\_\_\_\_  
 Address: \_\_\_\_\_ Department: \_\_\_\_\_  
 \_\_\_\_\_ Phone: \_\_\_\_\_  
 \_\_\_\_\_ Fax: \_\_\_\_\_

## Further information

<p><b><u>Bosch Rexroth Linear Motion Technology homepage</u></b></p>	
<p><b><u>Compact module product information (instruction, configurator, store, etc.)</u></b></p>	
<p><b><u>Smart Function Kit Handling (SFK-H)</u></b></p>	
<p><b><u>Product overview, automation solutions (motors, drives, control systems, etc.)</u></b></p>	



**Bosch Rexroth AG**

Ernst-Sachs-Straße 100  
97424 Schweinfurt, Germany  
Tel. +49 9721 937-0  
Fax +49 9721 937-275  
<https://www.boschrexroth.com>

Find your local contact person here:

<https://www.boschrexroth.com/en/xc/contact/index>



R999000479/2023-03  
replaces  
R999000479/2021-03  
© Bosch Rexroth AG 2023  
Subject to change without notice.

The data specified above only serves to describe the product.  
Due to the continuing development of our products, no statements  
concerning a certain condition or suitability for a certain application  
can be derived from our information. The information given does not  
release the user from the obligation of their own judgment and verification.  
Please note that our products are subject to a natural process of wear  
and aging.