

GTE

Planetary Gearboxes

Project Planning Manual
R911308842

Edition 09

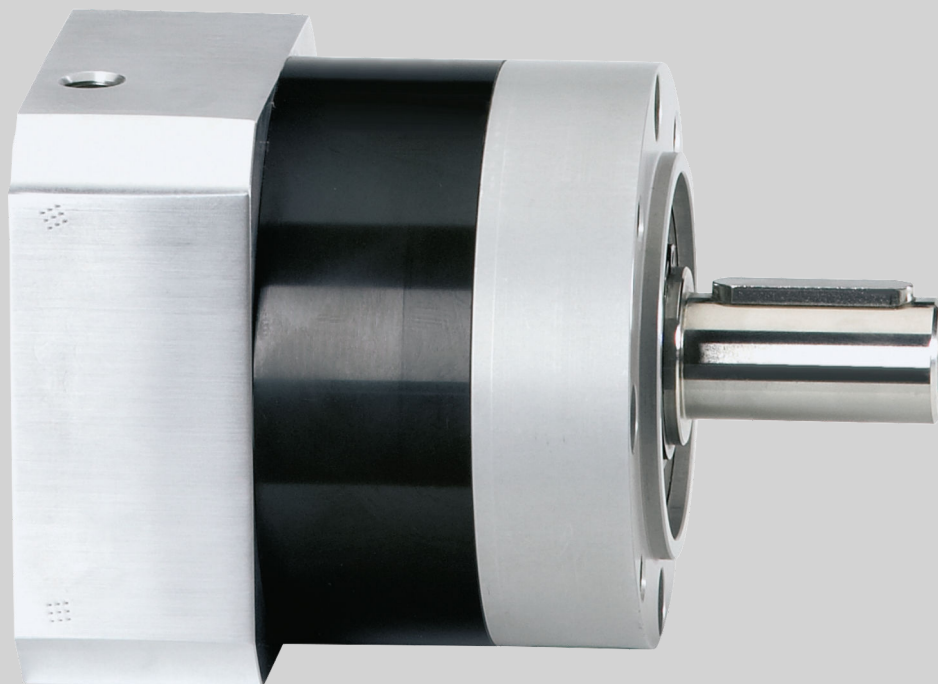

Title	GTE Planetary Gearboxes
Type of Documentation	Project Planning Manual
Document Typecode	DOK-GEAR**-GTE*****-PR09-EN-P
Internal File Reference	RS-20ad79a1d989be610a6846a0004ed7c2-6-en-US-5
Record of revisions	Edition 09, 2019-04 See tab. 1-1 "Record of revisions" on page 2.
Copyright	© Bosch Rexroth AG 2019 All rights reserved, also regarding any disposal, exploitation, reproduction, editing, distribution, as well as in the event of applications for industrial property rights.
Liability	The specified data is intended for product description purposes only and shall not be deemed to be a guaranteed characteristic unless expressly stipulated in the contract. All rights are reserved with respect to the content of this documentation and the availability of the product.
Published by	Bosch Rexroth AG Electric Drives and Controls Dept. DC-AE/EPI5 (fs) Buergermeister-Dr.-Nebel-Strasse 2 97816 Lohr, Germany Tel. +49 93 52 18 0 / Fax +49 93 52 18 8400 http://www.boschrexroth.com/electrics
Note	This document has been printed on chlorine-free bleached paper.

Table of Contents

	Page
1 Introduction to the product.....	1
1.1 GTE Planetary gearboxes.....	1
1.2 About this documentation.....	2
1.2.1 Editions of this documentation.....	2
1.2.2 General.....	2
1.2.3 Further documentation.....	3
1.2.4 Standards.....	3
1.3 Additional components.....	3
1.4 Your feedback.....	3
2 Important instructions on use.....	5
2.1 Intended use.....	5
2.1.1 Introduction.....	5
2.1.2 Areas of use and application.....	5
2.2 Non-intended use.....	6
3 Safety instructions for electric drives and controls.....	7
3.1 Definitions of terms.....	7
3.2 General information.....	8
3.2.1 Using the Safety instructions and passing them on to others.....	8
3.2.2 Requirements for safe use.....	8
3.2.3 Hazards by improper use.....	9
3.3 Instructions with regard to specific dangers.....	10
3.3.1 Protection against contact with electrical parts and housings.....	10
3.3.2 Protective extra-low voltage as protection against electric shock	11
3.3.3 Protection against dangerous movements.....	12
3.3.4 Protection against electromagnetic and magnetic fields during operation and mounting.....	13
3.3.5 Protection against contact with hot parts.....	14
3.3.6 Protection during handling and mounting.....	14
3.3.7 Battery safety.....	14
3.3.8 Protection against pressurized systems.....	15
3.4 Explanation of signal words and the Safety alert symbol.....	16
4 Dimensioning and selection.....	17
4.1 Dimensioning.....	17
4.2 Selection.....	18
5 Application notes.....	21
5.1 Operating conditions.....	21
5.1.1 General.....	21
5.1.2 Operating mode S5 (Intermitted operation).....	21
5.1.3 Operating mode S1 (Continuous operation).....	22
5.2 Operating gearboxes or motor/gearbox combinations in hazardous areas (ATEX).....	22

Table of Contents

	Page
5.3	Mechanical features..... 23
5.4	Combinations of GTE with motors 25
6	Technical data..... 27
6.1	Technical data for intermittent and continuous operation for intermittent and continuous operation... 27
6.1.1	GTE040..... 27
6.1.2	GTE060..... 28
6.1.3	GTE080..... 29
6.1.4	GTE120..... 30
6.1.5	GTE160..... 31
6.2	Maximum transferable output torque..... 32
6.3	Thermal specifications for S1 operation..... 33
6.4	Technical data at increased lifetime..... 34
6.5	Limiting temperature curves to determine higher S1-speed..... 35
6.5.1	General..... 35
6.5.2	GTE040..... 36
6.5.3	GTE060..... 37
6.5.4	GTE080..... 38
6.5.5	GTE120..... 39
6.5.6	GTE160..... 40
6.6	Permitted shaft load..... 41
6.6.1	General..... 41
6.6.2	GTE040..... 42
6.6.3	GTE060..... 43
6.6.4	GTE080..... 44
6.6.5	GTE120..... 45
6.6.6	GTE160..... 46
7	Specifications..... 47
7.1	GTE040..... 47
7.2	GTE060..... 48
7.3	GTE080..... 49
7.4	GTE120..... 50
7.5	GTE160..... 51
8	Type codes..... 53
8.1	Type code GTE040..... 53
8.2	Type code GTE060..... 54
8.3	Type code GTE080..... 55
8.4	Type code GTE120..... 56
8.5	Type code GTE160..... 57
9	Handling, transport and storage..... 59
9.1	Handling..... 59
9.1.1	Identifying the goods..... 59

	Page
9.1.2 Name plates.....	59
9.2 Transport and storage.....	60
10 Assembly.....	63
10.1 Skilled personnel.....	63
10.2 Motor mounting.....	63
10.2.1 General Information.....	63
10.2.2 Mounting procedure.....	64
10.3 Gearbox mounting.....	66
11 Commissioning, operation and maintenance.....	67
11.1 Start-up.....	67
11.1.1 General information.....	67
11.1.2 Preparation.....	67
11.1.3 Bulk head connector.....	67
11.2 Deactivation.....	68
11.3 Disassembly.....	68
11.4 Maintenance.....	68
11.4.1 General information.....	68
11.4.2 Measures.....	69
11.5 Troubleshooting	69
11.5.1 General information.....	69
11.5.2 Excess temperature of gearbox housing.....	69
11.5.3 Gearbox-motor unit generates vibrations.....	70
11.5.4 Specified position is not attained.....	70
12 Environmental protection and disposal	71
12.1 Environmental protection.....	71
12.2 Disposal.....	71
13 Service and support.....	73
Index.....	75

1 Introduction to the product

1.1 GTE Planetary gearboxes

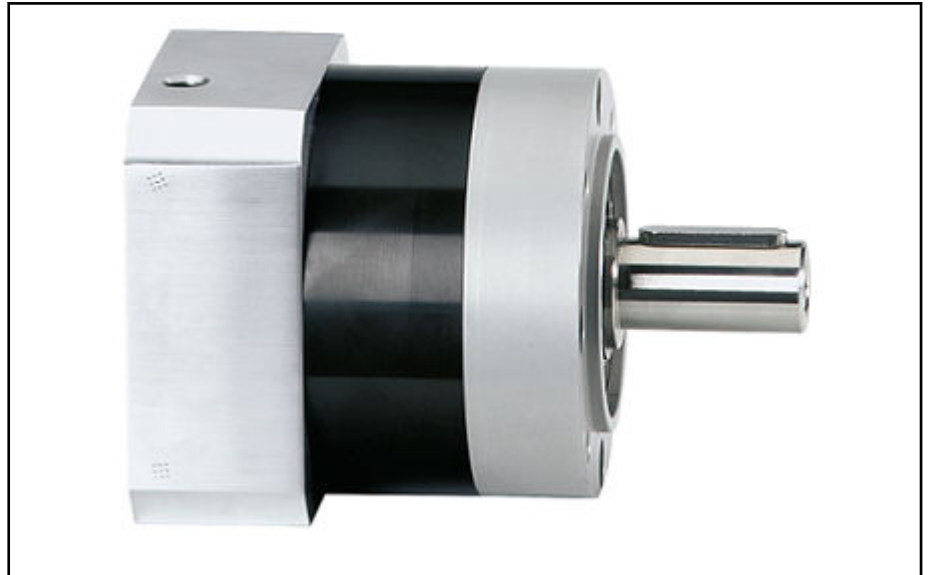

Fig. 1-1: GTE Planetary gearboxes

Fields of application	<p>In combination with the drive and control system of Rexroth, planetary gearboxes provide a low-cost automation system for various sectors of industry.</p> <p>They are well-suited for use with gear racks or toothed belts in handling systems with high speed and accelerations (e.g.: loader and robots).</p> <p>The low-backlash with shave-grinded (honed) planet wheels permits the execution of exact positioning tasks. Furthermore, the gearboxes are suited for S1-operation-required for application in e.g. the printing sector.</p>
Mode of functioning	<p>The GTE series of planetary gearboxes offers a coaxial input and output. The output shaft of the motor is connected to the sun gear with a non-positive compression clamp coupling. This sun gear drives three planetary wheels, which roll off on an internal gear with internal gear teeth, as a single-stage gearbox and four planetary wheels as a two-stage gearbox. The planetary gears are fixed in the planet carrier, which acts as the output. By dividing the load among the planetary gear on three or four planetary wheels, a balanced force splitting occurs. This allows for a very compact gearbox with a high power density.</p>
High operational reliability	<ul style="list-style-type: none"> • Maintenance-free operation through lifetime lubrication • Safe and lasting sealing by abrasion bearing sealants. • Hermetically sealed housing • Non-positive from backlash-free torque transmission via the compression coupling
High performance data	<ul style="list-style-type: none"> • High accuracy via shave grinded (honed) planetary wheels, low backlash gearing with low torque play. • High efficiency, low temperature and minimum power loss made possible by using the smallest possible seal diameters. • Low running noise by optimized gear profiles. • High emergency stop torque made possible by internal transferred power.

Easy to mount to machine

- Highly dynamic because of inertia
- Low weight through compact type of construction
- The high radial-load capability and tilt resistance makes it possible to directly mount a pinion or pulley.
- The design of the output shaft with a solid shaft shoulder makes axial tightening of output elements simple.
- The gearbox can be mounted in any position. Due to the defined bearing position and pump current a sufficient lubricant supply is always ensured.
- The output elements can be mounted in two different ways:
 - non-positive shaft-hub connection by means of a plain output hollow shaft, or
 - connection by means of an output shaft with keyway

1.2 About this documentation

1.2.1 Editions of this documentation

Edition	State	Note
09	2019-04	Revision / supplement (new type codes)
08	2013-04	Revision technical data
07	2012-11	Revision
...
01	2004-12	First edition

Tab. 1-1: Record of revisions

1.2.2 General

This document contains safety regulations, technical data, and operating instructions for gearboxes. The individual chapters can be subdivided into the following focal points:

Chapter	Title	Content
1	Product presentation	General information
2	Important instructions for use	Safety
3	Safety instructions	
4	Dimensioning and selection	Product description (for planners and designers)
5	Application notes	
6	Technical data	
7	Specifications	
8	Type code	
9	Handling, transport and storage	Practise (for operating and maintenance personnel)
10	Assembly	
11	Commissioning, operation and maintenance	

Chapter	Title	Content
12	Service & support	General information
13	Index	

Tab. 1-2: Document structure

1.2.3 Further documentation

To project planning manual the drive-systems it is possible that you need additional documentation referring the used devices. Rexroth provides the entire product documentation in the Bosch Rexroth media directory in PDF format.

<http://www.boschrexroth.com/various/utilities/mediadirectory/index.jsp>

1.2.4 Standards

This documentation refers to German, European and international technical standards. Documents and sheets on standards underlie the protection by copyright and may not be passed on to third parties by Rexroth Indramat. If required, please contact the authorized sales outlets. In Germany, contact:

BEUTH Verlag GmbH

Burggrafenstrasse 6

10787 Berlin

Tel. +49 (0) 30 – 26 01-22 60, Fax +49 (0) 30 – 26 01-12 60

Internet: <http://www.din.be/beuth>

Email: postmaster@beuth.de

1.3 Additional components

Documentation for external systems which are connected to Bosch Rexroth components are not included in the scope of delivery and must be ordered directly from the corresponding manufacturers.

1.4 Your feedback

Your experiences are an essential part of the improvement process of product and documentation.

Please send your feedback to:

Bosch Rexroth AG

Dept. DC-AE/EPI5 (fs/mb)

Buergermeister-Dr.-Nebel-Straße 2

97816 Lohr am Main, Germany

E-Mail: dokusupport@boschrexroth.de

2 Important instructions on use

2.1 Intended use

2.1.1 Introduction

Rexroth products are developed and manufactured according to the state of the art. Before they are delivered, they are inspected to ensure that they operate safely.

The products must only be used as intended. If they are inappropriately used, situations may arise resulting in injuries to property and persons.



Rexroth, as the manufacturer, does not provide any warranty, assume any liability, or pay any damages for damage caused by products not being used as intended. Any risks resulting from the products not being used as intended are the sole responsibility of the user.

Before using the Bosch Rexroth products, the following condition precedent must be fulfilled so as to ensure that they are used as intended:

- Personnel that in any way, shape or form uses our products must first read and understand the relevant safety instructions and be familiar with their appropriate use.
- If the products are hardware, they must be kept in their original state, i.e., no constructional modifications may be made. Software products may not be decompiled; their source codes may not be modified.
- Damaged or improperly working products may not be installed or put into operation.
- It must be ensured that the products are installed according to the regulations specified in the documentation.

2.1.2 Areas of use and application

Typical application ranges of the GTE planetary gearboxes are:

- Handling and mounting systems,
- Packaging and food-processing machines,
- Printing and Paper-processing machines and

Controlling and monitoring of the motor/-gearbox combination may require connection of additional sensors and actuators.



The gearboxes may only be used with the accessories specified in the documentation. Components that are not explicitly mentioned may neither be attached nor connected. The same is applicable for cables and lines.



Operation is only allowed in the explicitly mentioned configurations and combinations of the component and with the software and firmware specified in the corresponding functional description.

Any drive controller must be programmed before startup, in order to ensure that the motor executes the functions specific to the particular application.

The gearboxes may only be operated under the assembly, mounting and installation conditions, in the normal position, and under the environmental conditions (temperature, degree of protection, humidity, EMC, and the like) specified in this documentation.

2.2 Non-intended use

Any use of gearboxes outside of the fields of application mentioned above or under operating conditions and technical data other than those specified in this documentation is considered as "non-intended use".

Planetary gearboxes may not be used if . . .

- they are subject to operating conditions which do not comply with the ambient conditions described above; For example, they may not be operated under water, under extreme temperature fluctuations or extreme maximum temperatures;
- the intended application is not explicitly released by Bosch Rexroth. Please be absolutely sure to comply with the instructions given in the general safety instructions!

3 Safety instructions for electric drives and controls

3.1 Definitions of terms

Application documentation	Application documentation comprises the entire documentation used to inform the user of the product about the use and safety-relevant features for configuring, integrating, installing, mounting, commissioning, operating, maintaining, repairing and decommissioning the product. The following terms are also used for this kind of documentation: Operating Instructions, Commissioning Manual, Instruction Manual, Project Planning Manual, Application Description, etc.
Component	A component is a combination of elements with a specified function, which are part of a piece of equipment, device or system. Components of the electric drive and control system are, for example, supply units, drive controllers, mains choke, mains filter, motors, cables, etc.
Control system	A control system comprises several interconnected control components placed on the market as a single functional unit.
Device	A device is a finished product with a defined function, intended for users and placed on the market as an individual piece of merchandise.
Electrical equipment	Electrical equipment encompasses all devices used to generate, convert, transmit, distribute or apply electrical energy, such as electric motors, transformers, switching devices, cables, lines, power-consuming devices, circuit board assemblies, plug-in units, control cabinets, etc.
Electric drive system	An electric drive system comprises all components from mains supply to motor shaft; this includes, for example, electric motor(s), motor encoder(s), supply units and drive controllers, as well as auxiliary and additional components, such as mains filter, mains choke and the corresponding lines and cables.
Installation	An installation consists of several devices or systems interconnected for a defined purpose and on a defined site which, however, are not intended to be placed on the market as a single functional unit.
Machine	A machine is the entirety of interconnected parts or units at least one of which is movable. Thus, a machine consists of the appropriate machine drive elements, as well as control and power circuits, which have been assembled for a specific application. A machine is, for example, intended for processing, treatment, movement or packaging of a material. The term "machine" also covers a combination of machines which are arranged and controlled in such a way that they function as a unified whole.
Manufacturer	The manufacturer is an individual or legal entity bearing responsibility for the design and manufacture of a product which is placed on the market in the individual's or legal entity's name. The manufacturer can use finished products, finished parts or finished elements, or contract out work to subcontractors. However, the manufacturer must always have overall control and possess the required authority to take responsibility for the product.
Product	Examples of a product: Device, component, part, system, software, firmware, among other things.
Project Planning Manual	A Project Planning Manual is part of the application documentation used to support the sizing and planning of systems, machines or installations.
Qualified persons	In terms of this application documentation, qualified persons are those persons who are familiar with the installation, mounting, commissioning and operation of the components of the electric drive and control system, as well as with the hazards this implies, and who possess the qualifications their work

requires. To comply with these qualifications, it is necessary, among other things,

- to be trained, instructed or authorized to switch electric circuits and devices safely on and off, to ground them and to mark them.
- to be trained or instructed to maintain and use adequate safety equipment.
- to attend a course of instruction in first aid.

Qualified personnel for handling functionally safe products

Individuals configuring, commissioning and operating functionally safe products must have the knowledge specified under "[Qualified persons](#)". Additionally, these individuals must be familiar with technical safety concepts as well as prevailing standards and regulations in the field of functional safety.

User

A user is a person installing, commissioning or using a product which has been placed on the market.

3.2 General information

3.2.1 Using the Safety instructions and passing them on to others

Do not attempt to install and operate the components of the electric drive and control system without first reading all documentation provided with the product. Read and understand these safety instructions and all user documentation prior to working with these components. If you do not have the user documentation for the components, contact your responsible Rexroth sales partner. Ask for these documents to be sent immediately to the person or persons responsible for the safe operation of the components.

If the component is resold, rented and/or passed on to others in any other form, these safety instructions must be delivered with the component in the official language of the user's country.

Improper use of these components, failure to follow the safety instructions in this document or tampering with the product, including disabling of safety devices, could result in property damage, injury, electric shock or even death.

3.2.2 Requirements for safe use

Read the following instructions before initial commissioning of the components of the electric drive and control system in order to eliminate the risk of injury and/or property damage. You must follow these safety instructions.

- Rexroth is not liable for damages resulting from failure to observe the safety instructions.
- Read the operating, maintenance and safety instructions in your language before commissioning. If you find that you cannot completely understand the application documentation in the available language, please ask your supplier to clarify.
- Proper and correct transport, storage, mounting and installation, as well as care in operation and maintenance, are prerequisites for optimal and safe operation of the component.
- Only qualified persons may work with components of the electric drive and control system or within its proximity.
- Only use accessories and spare parts approved by Rexroth.
- Follow the safety regulations and requirements of the country in which the components of the electric drive and control system are operated.

- Only use the components of the electric drive and control system in the manner that is defined as appropriate. See chapter "Appropriate Use".
- The ambient and operating conditions given in the available application documentation must be observed.
- Applications for functional safety are only allowed if clearly and explicitly specified in the application documentation "Integrated Safety Technology". If this is not the case, they are excluded. Functional safety is a safety concept in which measures of risk reduction for personal safety depend on electrical, electronic or programmable control systems.
- The information given in the application documentation with regard to the use of the delivered components contains only examples of applications and suggestions.

The machine and installation manufacturers must

- make sure that the delivered components are suited for their individual application and check the information given in this application documentation with regard to the use of the components,
- make sure that their individual application complies with the applicable safety regulations and standards and carry out the required measures, modifications and complements.
- Commissioning of the delivered components is only allowed once it is sure that the machine or installation in which the components are installed complies with the national regulations, safety specifications and standards of the application.
- Operation is only allowed if the national EMC regulations for the application are met.
- The instructions for installation in accordance with EMC requirements can be found in the section on EMC in the respective application documentation.

The machine or installation manufacturer is responsible for compliance with the limit values as prescribed in the national regulations.

- The technical data, connection and installation conditions of the components are specified in the respective application documentations and must be followed at all times.

National regulations which the user has to comply with

- European countries: In accordance with European EN standards
- United States of America (USA):
 - National Electrical Code (NEC)
 - National Electrical Manufacturers Association (NEMA), as well as local engineering regulations
 - Regulations of the National Fire Protection Association (NFPA)
- Canada: Canadian Standards Association (CSA)
- Other countries:
 - International Organization for Standardization (ISO)
 - International Electrotechnical Commission (IEC)

3.2.3 Hazards by improper use

- High electrical voltage and high working current! Danger to life or serious injury by electric shock!

- High electrical voltage by incorrect connection! Danger to life or injury by electric shock!
- Dangerous movements! Danger to life, serious injury or property damage by unintended motor movements!
- Health hazard for persons with heart pacemakers, metal implants and hearing aids in proximity to electric drive systems!
- Risk of burns by hot housing surfaces!
- Risk of injury by improper handling! Injury by crushing, shearing, cutting, hitting!
- Risk of injury by improper handling of batteries!
- Risk of injury by improper handling of pressurized lines!

3.3 Instructions with regard to specific dangers

3.3.1 Protection against contact with electrical parts and housings



This section concerns components of the electric drive and control system with voltages of **more than 50 volts**.

Contact with parts conducting voltages above 50 volts can cause personal danger and electric shock. When operating components of the electric drive and control system, it is unavoidable that some parts of these components conduct dangerous voltage.

High electrical voltage! Danger to life, risk of injury by electric shock or serious injury!

- Only qualified persons are allowed to operate, maintain and/or repair the components of the electric drive and control system.
- Follow the general installation and safety regulations when working on power installations.
- Before switching on, the equipment grounding conductor must have been permanently connected to all electric components in accordance with the connection diagram.
- Even for brief measurements or tests, operation is only allowed if the equipment grounding conductor has been permanently connected to the points of the components provided for this purpose.
- Before accessing electrical parts with voltage potentials higher than 50 V, you must disconnect electric components from the mains or from the power supply unit. Secure the electric component from reconnection.
- With electric components, observe the following aspects:
Always wait **30 minutes** after switching off power to allow live capacitors to discharge before accessing an electric component. Measure the electrical voltage of live parts before beginning to work to make sure that the equipment is safe to touch.
- Install the covers and guards provided for this purpose before switching on.
- Never touch any electrical connection points of the components while power is turned on.

- Do not remove or plug in connectors when the component has been powered.
- Under specific conditions, electric drive systems can be operated at mains protected by residual-current-operated circuit-breakers sensitive to universal current (RCDs/RCMs).
- Secure built-in devices from penetrating foreign objects and water, as well as from direct contact, by providing an external housing, for example a control cabinet.

High housing voltage and high leakage current! Danger to life, risk of injury by electric shock!

- Before switching on and before commissioning, ground or connect the components of the electric drive and control system to the equipment grounding conductor at the grounding points.
- Connect the equipment grounding conductor of the components of the electric drive and control system permanently to the main power supply at all times. The leakage current is greater than 3.5 mA.
- Establish an equipment grounding connection with a minimum cross section according to the table below. With an outer conductor cross section smaller than 10 mm² (8 AWG), the alternative connection of two equipment grounding conductors is allowed, each having the same cross section as the outer conductors.

Cross section outer conductor	Minimum cross section equipment grounding conductor Leakage current ≥ 3.5 mA	
	1 equipment grounding conductor	2 equipment grounding conductors
1.5 mm ² (16 AWG)	10 mm ² (8 AWG)	2 × 1.5 mm ² (16 AWG)
2.5 mm ² (14 AWG)		2 × 2.5 mm ² (14 AWG)
4 mm ² (12 AWG)		2 × 4 mm ² (12 AWG)
6 mm ² (10 AWG)		2 × 6 mm ² (10 AWG)
10 mm ² (8 AWG)		-
16 mm ² (6 AWG)	16 mm ² (6 AWG)	-
25 mm ² (4 AWG)		-
35 mm ² (2 AWG)		-
50 mm ² (1/0 AWG)	25 mm ² (4 AWG)	-
70 mm ² (2/0 AWG)	35 mm ² (2 AWG)	-
...

Tab. 3-1: Minimum cross section of the equipment grounding connection

3.3.2 Protective extra-low voltage as protection against electric shock

Protective extra-low voltage is used to allow connecting devices with basic insulation to extra-low voltage circuits.

On components of an electric drive and control system provided by Rexroth, all connections and terminals with voltages up to 50 volts are PELV ("Protec-

tive Extra-Low Voltage") systems. It is allowed to connect devices equipped with basic insulation (such as programming devices, PCs, notebooks, display units) to these connections.

Danger to life, risk of injury by electric shock! High electrical voltage by incorrect connection!

If extra-low voltage circuits of devices containing voltages and circuits of more than 50 volts (e.g., the mains connection) are connected to Rexroth products, the connected extra-low voltage circuits must comply with the requirements for PELV ("Protective Extra-Low Voltage").

3.3.3 Protection against dangerous movements

Dangerous movements can be caused by faulty control of connected motors. Some common examples are:

- Improper or wrong wiring or cable connection
- Operator errors
- Wrong input of parameters before commissioning
- Malfunction of sensors and encoders
- Defective components
- Software or firmware errors

These errors can occur immediately after equipment is switched on or even after an unspecified time of trouble-free operation.

The monitoring functions in the components of the electric drive and control system will normally be sufficient to avoid malfunction in the connected drives. Regarding personal safety, especially the danger of injury and/or property damage, this alone cannot be relied upon to ensure complete safety. Until the integrated monitoring functions become effective, it must be assumed in any case that faulty drive movements will occur. The extent of faulty drive movements depends upon the type of control and the state of operation.

Dangerous movements! Danger to life, risk of injury, serious injury or property damage!

A **risk assessment** must be prepared for the installation or machine, with its specific conditions, in which the components of the electric drive and control system are installed.

As a result of the risk assessment, the user must provide for monitoring functions and higher-level measures on the installation side for personal safety. The safety regulations applicable to the installation or machine must be taken into consideration. Unintended machine movements or other malfunctions are possible if safety devices are disabled, bypassed or not activated.

To avoid accidents, injury and/or property damage:

- Keep free and clear of the machine's range of motion and moving machine parts. Prevent personnel from accidentally entering the machine's range of motion by using, for example:
 - Safety fences
 - Safety guards
 - Protective coverings
 - Light barriers

- Make sure the safety fences and protective coverings are strong enough to resist maximum possible kinetic energy.
- Mount emergency stopping switches in the immediate reach of the operator. Before commissioning, verify that the emergency stopping equipment works. Do not operate the machine if the emergency stopping switch is not working.
- Prevent unintended start-up. Isolate the drive power connection by means of OFF switches/OFF buttons or use a safe starting lockout.
- Make sure that the drives are brought to safe standstill before accessing or entering the danger zone.
- Additionally secure vertical axes against falling or dropping after switching off the motor power by, for example,
 - mechanically securing the vertical axes,
 - adding an external braking/arrester/clamping mechanism or
 - ensuring sufficient counterbalancing of the vertical axes.
- The standard equipment **motor holding brake** or an external holding brake controlled by the drive controller is **not sufficient to guarantee personal safety!**
- Disconnect electrical power to the components of the electric drive and control system using the master switch and secure them from reconnection ("lock out") for:
 - Maintenance and repair work
 - Cleaning of equipment
 - Long periods of discontinued equipment use
- Prevent the operation of high-frequency, remote control and radio equipment near components of the electric drive and control system and their supply leads. If the use of these devices cannot be avoided, check the machine or installation, at initial commissioning of the electric drive and control system, for possible malfunctions when operating such high-frequency, remote control and radio equipment in its possible positions of normal use. It might possibly be necessary to perform a special electromagnetic compatibility (EMC) test.

3.3.4 Protection against electromagnetic and magnetic fields during operation and mounting

Electromagnetic and magnetic fields!

Health hazard for persons with active implantable medical devices (AIMD) such as pacemakers or passive metallic implants.

- Hazards for the above-mentioned groups of persons by electromagnetic and magnetic fields in the immediate vicinity of drive controllers and the associated current-carrying conductors.
- Entering these areas can pose an increased risk to the above-mentioned groups of persons. They should seek advice from their physician.
- If overcome by possible effects on above-mentioned persons during operation of drive controllers and accessories, remove the exposed persons from the vicinity of conductors and devices.

3.3.5 Protection against contact with hot parts

Hot surfaces of components of the electric drive and control system. Risk of burns!

- Do not touch hot surfaces of, for example, braking resistors, heat sinks, supply units and drive controllers, motors, windings and laminated cores!
- According to the operating conditions, temperatures of the surfaces can be **higher than 60 °C (140 °F)** during or after operation.
- Before touching motors after having switched them off, let them cool down for a sufficient period of time. Cooling down can require **up to 140 minutes!** The time required for cooling down is approximately five times the thermal time constant specified in the technical data.
- After switching chokes, supply units and drive controllers off, wait **15 minutes** to allow them to cool down before touching them.
- Wear safety gloves or do not work at hot surfaces.
- For certain applications, and in accordance with the respective safety regulations, the manufacturer of the machine or installation must take measures to avoid injuries caused by burns in the final application. These measures can be, for example: Warnings at the machine or installation, guards (shieldings or barriers) or safety instructions in the application documentation.

3.3.6 Protection during handling and mounting

Risk of injury by improper handling! Injury by crushing, shearing, cutting, hitting!

- Observe the relevant statutory regulations of accident prevention.
- Use suitable equipment for mounting and transport.
- Avoid jamming and crushing by appropriate measures.
- Always use suitable tools. Use special tools if specified.
- Use lifting equipment and tools in the correct manner.
- Use suitable protective equipment (hard hat, safety goggles, safety shoes, safety gloves, for example).
- Do not stand under hanging loads.
- Immediately clean up any spilled liquids from the floor due to the risk of falling!

3.3.7 Battery safety

Batteries consist of active chemicals in a solid housing. Therefore, improper handling can cause injury or property damage.

Risk of injury by improper handling!

- Do not attempt to reactivate low batteries by heating or other methods (risk of explosion and cauterization).
- Do not attempt to recharge the batteries as this may cause leakage or explosion.
- Do not throw batteries into open flames.
- Do not dismantle batteries.

- When replacing the battery/batteries, do not damage the electrical parts installed in the devices.
- Only use the battery types specified for the product.



Environmental protection and disposal! The batteries contained in the product are considered dangerous goods during land, air, and sea transport (risk of explosion) in the sense of the legal regulations. Dispose of used batteries separately from other waste. Observe the national regulations of your country.

3.3.8 Protection against pressurized systems

According to the information given in the Project Planning Manuals, motors and components cooled with liquids and compressed air can be partially supplied with externally fed, pressurized media, such as compressed air, hydraulics oil, cooling liquids and cooling lubricants. Improper handling of the connected supply systems, supply lines or connections can cause injuries or property damage.

Risk of injury by improper handling of pressurized lines!

- Do not attempt to disconnect, open or cut pressurized lines (risk of explosion).
- Observe the respective manufacturer's operating instructions.
- Before dismounting lines, relieve pressure and empty medium.
- Use suitable protective equipment (safety goggles, safety shoes, safety gloves, for example).
- Immediately clean up any spilled liquids from the floor due to the risk of falling!



Environmental protection and disposal! The agents (e.g., fluids) used to operate the product might not be environmentally friendly. Dispose of agents harmful to the environment separately from other waste. Observe the national regulations of your country.

3.4 Explanation of signal words and the Safety alert symbol

The Safety Instructions in the available application documentation contain specific signal words (DANGER, WARNING, CAUTION or NOTICE) and, where required, a safety alert symbol (in accordance with ANSI Z535.6-2011).

The signal word is meant to draw the reader's attention to the safety instruction and identifies the hazard severity.

The safety alert symbol (a triangle with an exclamation point), which precedes the signal words DANGER, WARNING and CAUTION, is used to alert the reader to personal injury hazards.

DANGER

In case of non-compliance with this safety instruction, death or serious injury **will** occur.

WARNING

In case of non-compliance with this safety instruction, death or serious injury **could** occur.

CAUTION

In case of non-compliance with this safety instruction, minor or moderate injury could occur.

NOTICE

In case of non-compliance with this safety instruction, property damage could occur.

4 Dimensioning and selection

4.1 Dimensioning

Applications for GTE planetary gearboxes are characterized by the following speed-time-curves:

- Triangular speed curve with pause interval
- Operation with constant speed and pause interval
- Operation with trapezoidal speed curve and pause interval
- Continuous operation without pause interval (S1)

The speed-time curves define the dimension criteria.

Triangular operation with pause interval

This operating mode is characteristic for all highly-dynamic feeds. These are often found in roll-feed mechanisms in the sheet-metal, paper, plastic and packaging industries.

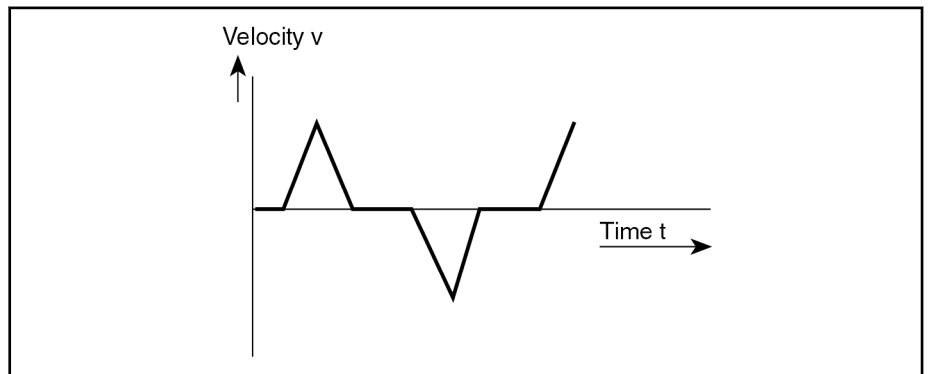

Fig. 4-1: Speed-time curve for triangle operation

The dimensioning of this operation is mainly made according to the necessary maximum torque M_{\max} and the average velocity V_{average} resp. mean speed n_{average} .

Continuous operation with pause interval

This operation is characteristic for all highly-dynamic feeds. These are often found in winding machines, drive rolls and in portioning devices in the sheet-metal, paper, plastic and packaging industry.

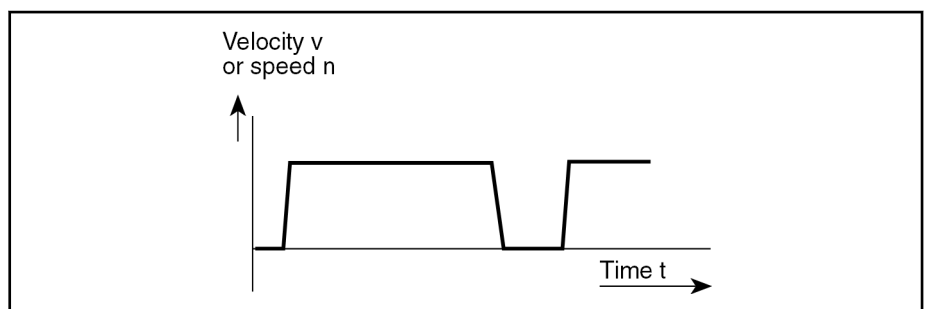

Fig. 4-2: Speed-time diagram for operation with constant speed

The dimensioning of this operation is mainly made according to the necessary maximum torque M_{\max} and the average velocity V_{average} resp. mean speed n_{average} .

Triangular operation with pause interval

This mode of operation is characteristic for the most highly-dynamic feeds. They can be found in loaders and handling systems in nearly all industry sectors.

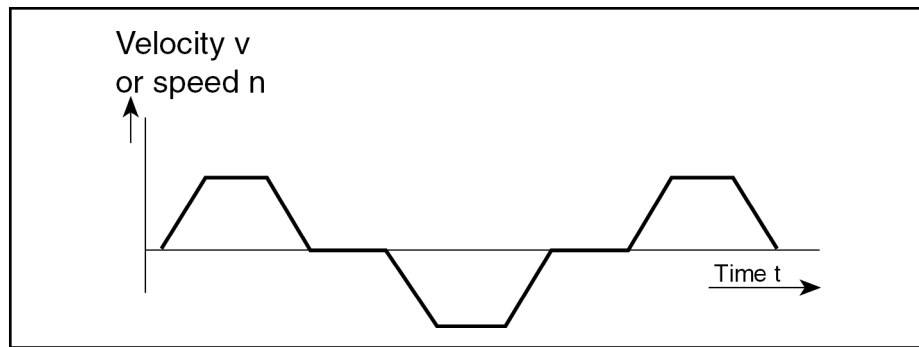

Fig. 4-3: Speed-time-graph for triangle operation

The dimensioning of this operation is mainly made according to the necessary maximum torque M_{\max} and the average velocity V_{average} resp. mean speed n_{average} .

Continuous operation without pause interval (S1)

This mode of operation is characteristic for drives in printing machines.

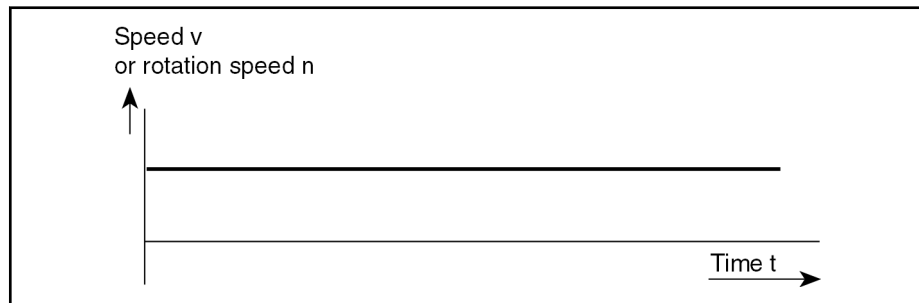

Fig. 4-4: Speed-time graph for constant speed

The dimensioning is made according to the necessary continuous torque M_{dN} and the velocity v or the speed n .

4.2 Selection

Drive-determined sizes

The selection of the suitable motor/-gearbox combination, operating with a drive control device, is to be taking in the following into consideration:

- Frictional torque
- Starting torque
- Processing torque
- Accelerating torque
- Effective torque
- Necessary speed
- Duty cycle

Dimensioning criteria

The motor-gearbox combination must fulfill the following conditions:

- The necessary speed must be reached.
- The continuous torque rating of the motor-gearbox combination has to be higher than the effective load torque.
- The intermittent torque has to be higher than the sum of the frictional, starting and processing torque.
- The maximum torque has to be higher than the sum of frictional, weight and processing torque.
- The required acceleration time has to be within the limit of the relevant drive selection lists.

- The thermal use-limit of the motor-gearbox combination must be adhered.
- The cycles of the operation modes S4 and S5 should not exceed 1,000 cycles per hour. If higher cycle rates than 1000 cycles are necessary, the gearbox must be derated accordingly (see 5-3)



It must be ensured that

- the maximum motor torque is smaller than the maximum gearbox input torque.
- the maximum motor speed is smaller than the maximum permissible gearbox-input speed.

Dimensioning motor-gearbox combinations

Due to the self-heating of the gearboxes depending on the speed, the cooling effect in the flange mounting area is limited. A speed-dependent reduction of the specified performance data is necessary, to do not overload motors when using gearboxes.



The standard value of reduction of the **S1 60K characteristic curve** in gearbox mounting is **20 - 30 %**. In case of thermally critical applications (e.g. flange temperatures > 80 °C), Bosch Rexroth recommends to check the temperature load at the gearbox and the motor.

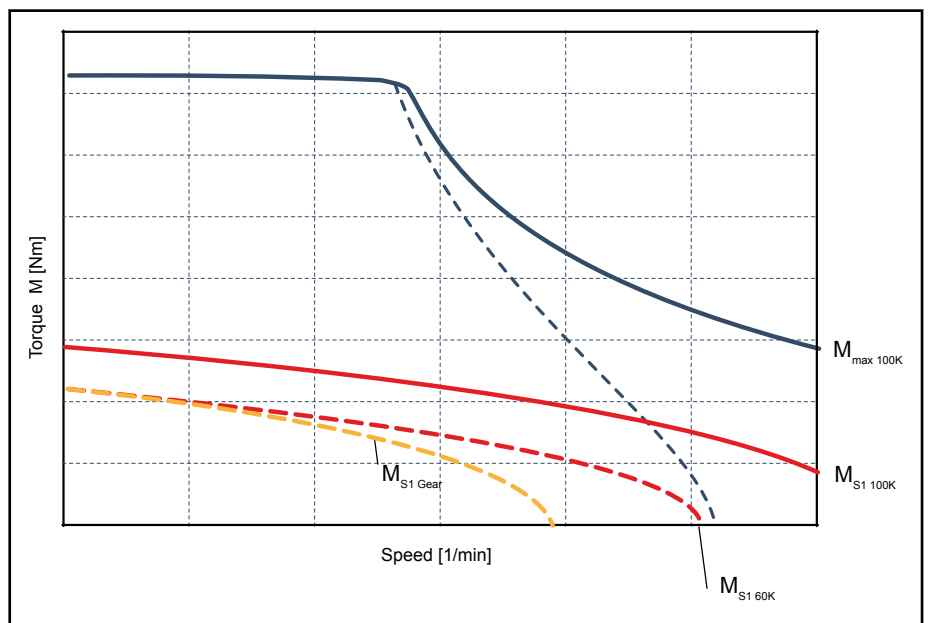

Fig. 4-5: S1 characteristic curve in gearbox

Calculate the characteristic curves for your application by using the sizing tool IndraSize: www.boschrexroth.com/.../IndraSize

By using the IndraSize software, drive controllers, motors and mechanic gearboxes can be easily sized. The engineering tool covers the entire range of Rexroth drives and motors.

5 Application notes

5.1 Operating conditions

5.1.1 General

Ambient temperature and installation altitude

The specified technical data of gearboxes (see chapter [Technical data](#)) are based on

- Ambient temperature: +30 °C
- Installation altitude 0 ... 1000 m above sea level



In the case of different conditions (higher ambient temperature and/or higher installation altitude), the performance data are limited and a derating according to the selected motor-gearbox combinations must be observed. Please also observe the guidelines in this documentation.

Degree of protection

The protection class of the motor (IP54 to IP65) and gearboxes (IP54) is designed in accordance with DIN EN 60529 (VDE 0470-1):2014-09. Please note, however, that the degree of protection of a motor/gearbox combination depends on the motor version selected, e.g. motor with or without shaft seal. For a motor/gearbox combination, the lowest protection class of a component in this overall system therefore always applies. Observe the motor-specific notes on the degree of protection in the respective motor project planning.

5.1.2 Operating mode S5 (Intermittent operation)

Planetary gearboxes of GTE series are suitable for the operating mode S5 (intermittent operation with braking) according to EN 60034-1. The operation time should herewith not surpass 60%.

$$ED = \frac{T_A + T_B + T_{Br}}{T_s} \cdot 100\% \leq 60\%$$

Fig. 5-1: Operation time for intermittent operation

A procedure during intermittent duty, which consists of an acceleration and a braking, is defined as a cycle.

The specified data of the gearboxes in the chapter "Technical data" are valid up to 1,000 cycles per hour.

Are more than 1,000 cycles per hour during operation of the gearbox necessary, the technical data have to be reduced by a factor (see [5-3](#)).

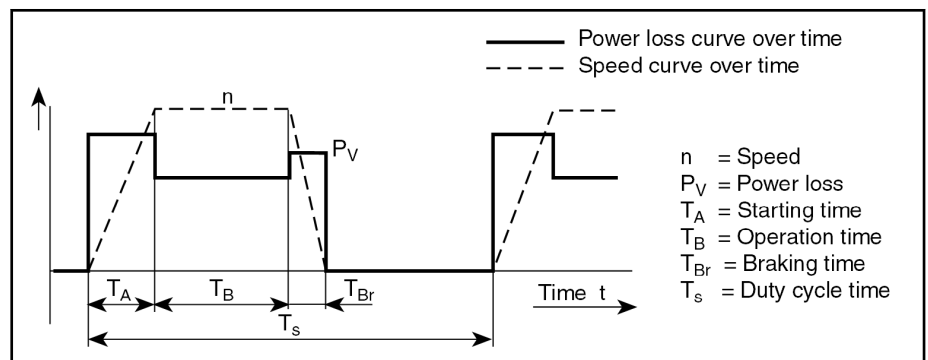

Fig. 5-2: Operating mode S5 (intermittent duty with electrical braking)

Reduction at higher cycles Are higher cycles than 1,000 cycles per hour needed, the following reduced technical data, regarding torque and power are valid.

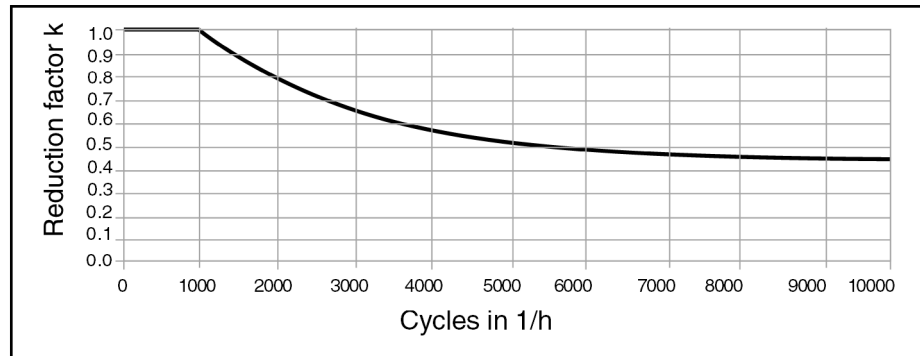

Fig. 5-3: Reduction factor at higher cycles

5.1.3 Operating mode S1 (Continuous operation)

Planetary gearboxes GTE are suited for the operating mode S1 according to EN 60034-1.

5.2 Operating gearboxes or motor/gearbox combinations in hazardous areas (ATEX)



Bosch Rexroth has no ATEX standard gearboxes in its product range.

Selecting ATEX gearboxes and the attachment of such gearboxes to Rexroth motors is in the sole responsibility of the machine manufacturer. The user is also responsible for compliance with applicable regulations for use in potentially explosive atmospheres.

5.3 Mechanical features

Type of construction, installation position Rexroth planetary gearboxes GTE are manufactured in the construction B05 for flange mounting. According to DIN EN 60034-7 (VDE 0530 Part 7): 2001-12, the mounting positions shown in the following table can be applied.

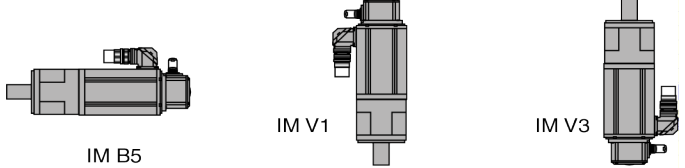
Gearbox - Type of construction	Permissible installation positions according to EN 60034-7:1996-06	Important installation note for vertical mounting positions IM V3
B05		When installing IM V3 (vertically, output shaft upwards) dam of liquid on the drive shaft has to be avoided, as liquid can penetrate into the motor-gearbox-combination over a longer period of time.

Tab. 5-1: Allowed installation positions

Output shaft The output shaft of the planetary gearboxes is available in the following variants:

- **Smooth output shaft (standard)**

For a plain non-positive shaft-hub connection.

Therewith, a higher smooth running and a free of clearance connection between shaft and hub.



We recommend to use output shafts with non-positive shaft-hub connections.

or

- **Output shaft with keyway acc. to DIN 6885-1:1968-08**

For a form-fitting shaft-hub connection.

This connection mode is suitable for absorption of direction-constant speed at low demand. It makes an additional axial safety of the hub necessary. Therefore, the frontal of the gearbox output shaft is provided with a centering hole with a thread (see dimension sheet).

Shaft load To check the shaft load, the axial and radial shaft load have to be checked separately:

The **radial shaft load** radial shaft load with subject to

- the point of application of force and
- mean speed

refer to the diagram in [Chapter Permitted shaft load](#). For the rated bearing lifetime were 30,000 operation hours taken as basis (bearing calculation according to DIN ISO 281:1993-01).

The **axial shaft load** is also described in [Chapter Permitted shaft load](#)

Assembly of output elements

The output shaft of the GTE gearboxes is fitted with a massive shaft shoulder, which is well-suited for the support of axial forces, especially at key connections.

The according tightening torque (T_A), resp. preliminary-tension forces (F_V), for mounting the output unit have to be taken from the following table.

Size (one-stage & two-stage)					
	GTE040	GTE060	GTE080	GTE120	GTE160
Thread	M3	M5	M6	M10	M16
T_A [Nm]	1.2	5.5	9.5	46	195
F_V [kN]	2.1	6.5	9.0	25	70

Tab. 5-2: Tightening torque and preload at mounting the drive units

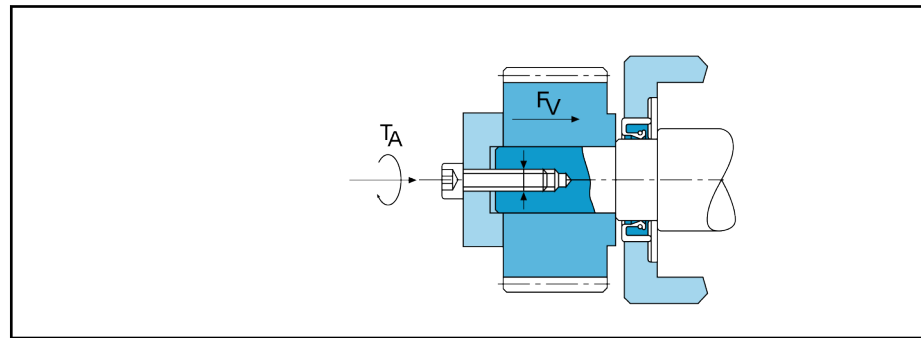

T_A Tightening torque
 F_V Preload

Fig. 5-4: Output shaft

5.4 Combinations of GTE with motors

Possible motor/gearbox combination with GTE planetary gearboxes

Gearbox	Motor type			
	MS2N	MSM	KSM	MSK
GTE040	-/-	019A 019B	-/-	-/-
GTE060	03-B 03-D	031B	-/-	MSK030
GTE080	03-B 03-D 04-x	031C 041B	041	030 040 043
GTE120	04-x 05-x 06-x	041B	041 061	040 043 050 060 061
GTE160	05-x 06-x 07-x	-/-	061 071 076	050 060 061 070 071 075 076 100

Tab. 5-3: Motor/gearbox combinations with GTE planetary gearboxes



To mount the GTE planetary gearboxes on motors, the motors must have a smooth drive shaft.

6 Technical data

6.1 Technical data for intermittent and continuous operation for intermittent and continuous operation

6.1.1 GTE040

Transmission ratio	Symbol	Unit	one-stage					two-stage		
		i ⁶⁾	3	4	5	8	10	12	20	40
Maximum average drive speed at 50% T2N ⁵⁾ and S1 ¹⁰⁾	$n_{m_max\ 50\%}$	min ⁻¹	5000	5000	5000	5000	5000	5000	5000	5000
Maximum average drive speed at 100% T2N ⁵⁾ and S1 ¹⁰⁾	$n_{m_max\ 100\%}$	min ⁻¹	5000	5000	5000	5000	5000	5000	5000	5000
Max. input speed ⁵⁾	n_{in_max}	min ⁻¹	18.000	18.000	18.000	18.000	18.000	18.000	18.000	18.000
Max. output speed ⁵⁾	n_{out_max}	min ⁻¹	6.000	4.500	3.600	2.250	1.800	1.500	900	450
Nominal input torque ^{1) 7) 8)}	M_{in_nenn}	Nm	3.7	3.8	2.8	0.8	0.5	1.7	1.0	0.5
Nominal output torque ^{1) 7) 8)}	M_{out_nenn}	Nm	11	15	14	6	5	20	20	18
Nominal input torque ^{1) 9) 7) 9)}	M_{in_max}	Nm	5.9	6.0	4.4	1.3	0.8	2.7	1.6	0.7
Maximum input torque ^{1) 7) 8) 9)}	M_{out_max}	Nm	17.6	24	22	10	8	32	32	29
Backlash	$\Delta\phi$	arcmin	< 15	< 15	< 15	< 15	< 15	< 19	< 19	< 19
Torsion-proof	D	Nm/ arcmin	1	1	1	1	1	1.1	1.1	1.1
Efficiency ⁴⁾	η	%	98	98	98	96	95	96	96	94
Moment of inertia ¹¹⁾	J	kg cm ²	0.031	0.022	0.019	0.017	0.016	0.029	0.019	0.016
Mass	m	kg	0.35	0.35	0.35	0.35	0.35	0.45	0.45	0.45
Lifetime	L_H		30.000							
Lubrication			Lifetime							
Gearbox housing temperature ²⁾	T_G	°C	-25 ... 90							
Sound pressure level ³⁾	L_P	dB(A)	58							
Degree of protection			IP54							

- 1) These values refer to a speed of the output shaft of $n_{out} = 100$ min⁻¹ on duty cycle $K_A = 1$ and S1-mode for electrical machines and $T=30^\circ\text{C}$.
- 2) Referring to the middle of the housing surface
- 3) Sound pressure level in 1m distance; measured on drive speed of $n_{in} = 3,000$ min⁻¹ without load; $i=5$
- 4) Depends on ratio $n_{out} = 100$ min⁻¹
- 5) Allowed operating temperatures must be kept
- 6) Ratios ($i = n_{out} / n_{in}$)
- 7) Depends on the motor shaft diameter
- 8) With key, for tumscent load
- 9) Permitted for 30,000 revolutions at the output shaft
- 10) See [Chapter 6.3 Thermal specifications for S1 operation](#)
- 11) The moment of inertia relates to the input shaft and to standard motor shaft diameter

Tab. 6-1: GTE040 - Technical data

Technical data

6.1.2 GTE060

Transmission ratio	Symbol	Unit	one-stage					two-stage		
			i ⁶⁾	3	4	5	8	10	12	20
Maximum average drive speed at 50% T2N ⁵⁾ and S1 ¹⁰⁾	n _{m_max 50%}	min ⁻¹	4.500	4.500	4.500	4.500	4.500	4.500	4.500	4.500
Maximum average drive speed at 100% T2N ⁵⁾ and S1 ¹⁰⁾	n _{m_max 100%}	min ⁻¹	4.500	4.500	4.500	4.500	4.500	4.500	4.500	4.500
Max. input speed ⁵⁾	n _{in_max}	min ⁻¹	13.000	13.000	13.000	13.000	13.000	13.000	13.000	13.000
Max. output speed ⁵⁾	n _{out_max}	min ⁻¹	4.333	3.250	2.600	1.625	1.300	1.083	650	325
Nominal input torque ^{1) 7) 8)}	M _{in_nenn}	Nm	9.3	9.5	8.0	2.3	1.5	3.7	2.2	1.0
Nominal output torque ^{1) 7) 8)}	M _{out_nenn}	Nm	28	38	40	18	15	44	44	40
Nominal input torque ^{1) 7) 8) 9)}	M _{in_max}	Nm	15.0	15.3	12.8	3.6	2.4	5.8	3.5	1.6
Maximum input torque ^{1) 7) 8) 9)}	M _{out_max}	Nm	45	61	64	29	24	70	70	64
Backlash	Δφ	arcmin	< 10	< 10	< 10	< 10	< 10	< 12	< 12	< 12
Torsion-proof	D	Nm/ arcmin	2.3	2.3	2.3	2.3	2.3	2.5	2.5	2.5
Efficiency ⁴⁾	η	%	98	98	98	97	96	96	96	94
Moment of inertia ¹¹⁾	J	kg cm ²	0.135	0.093	0.078	0.065	0.064	0.127	0.075	0.064
Mass	m	kg	0.9	0.9	0.9	0.9	0.9	1.1	1.1	1.1
Lifetime	L _H		30.000							
Lubrication			Lifetime							
Gearbox housing temperature ²⁾	T _G	°C	-25 ... 90							
Sound pressure level ³⁾	L _P	dB(A)	58							
Degree of protection			IP54							

- 1) These values refer to a speed of the output shaft of n_{out} = 100 min⁻¹ on duty cycle K_A = 1 and S1-mode for electrical machines and T=30°C.
- 2) Referring to the middle of the housing surface
- 3) Sound pressure level in 1m distance; measured on drive speed of n_{in} = 3,000 min⁻¹ without load; i=5
- 4) Depends on ratio n_{out} = 100 min⁻¹
- 5) Allowed operating temperatures must be kept
- 6) Ratios (i= n_{out} / n_{in})
- 7) Depends on the motor shaft diameter
- 8) With key: for tumscent load
- 9) Permitted for 30,000 revolutions at the output shaft
- 10) See [Chapter 6.3 Thermal specifications for S1 operation](#)
- 11) The moment of inertia relates to the input shaft and to standard motor shaft diameter

Tab. 6-2: GTE60 - Technical data

6.1.3 GTE080

Transmission ratio	Symbol	Unit	one-stage					two-stage		
			3	4	5	8	10	12	20	40
Maximum average drive speed at 50% T2N ⁵⁾ and S1 ¹⁰⁾	n_{m_max} 50%	min ⁻¹	4.000	3.850	4.000	4.000	4.000	4.000	4.000	4.000
Maximum average drive speed at 100% T2N ⁵⁾ and S1 ¹⁰⁾	n_{m_max} 100%	min ⁻¹	2.700	2.500	3.000	4.000	4.000	3.750	4.000	4.000
Max. input speed ⁵⁾	n_{in_max}	min ⁻¹	7.000	7.000	7.000	7.000	7.000	7.000	7.000	7.000
Max. output speed ⁵⁾	n_{out_max}	min ⁻¹	2.333	1.750	1.400	875	700	583	350	175
Nominal input torque ^{1) 7) 8)}	M_{in_nenn}	Nm	28.3	28.8	22.0	6.3	3.8	10.0	6.0	2.8
Nominal output torque ^{1) 7) 8)}	M_{out_nenn}	Nm	85	115	110	50	38	120	120	110
Nominal input torque ^{1) 7) 8) 9)}	M_{in_max}	Nm	45.3	46.0	35.2	10.0	6.1	16.0	9.6	4.4
Maximum input torque ^{1) 7) 8) 9)}	M_{out_max}	Nm	136	184	176	80	61	192	192	176
Backlash	$\Delta\phi$	arcmin	< 7	< 7	< 7	< 7	< 7	< 9	< 9	< 9
Torsion-proof	D	Nm/ arcmin	6	6	6	6	6	6.5	6.5	6.5
Efficiency ⁴⁾	η	%	98	98	98	97	96	97	96	94
Moment of inertia ¹¹⁾	J	kg cm ²	0.77	0.52	0.45	0.39	0.39	0.72	0.44	0.39
Mass	m	kg	2.1	2.1	2.1	2.1	2.1	2.6	2.6	2.6
Lifetime	L_H		30.000							
Lubrication			Lifetime							
Gearbox housing temperature ²⁾	T_G	°C	-25 ... 90							
Sound pressure level ³⁾	L_P	dB(A)	60							
Degree of protection			IP54							

- 1) These values refer to a speed of the output shaft of $n_{out} = 100$ min⁻¹ on duty cycle $K_A = 1$ and S1-mode for electrical machines and $T=30^\circ\text{C}$.
- 2) Referring to the middle of the housing surface
- 3) Sound pressure level in 1m distance; measured on drive speed of $n_{in} = 3,000$ min⁻¹ without load; $i=5$
- 4) Depends on ratio $n_{out} = 100$ min⁻¹
- 5) Allowed operating temperatures must be kept
- 6) Ratios ($i = n_{out} / n_{in}$)
- 7) Depends on the motor shaft diameter
- 8) With key: for tumscent load
- 9) Permitted for 30,000 revolutions at the output shaft
- 10) See [Chapter 6.3 Thermal specifications for S1 operation](#)
- 11) The moment of inertia relates to the input shaft and to standard motor shaft diameter

Tab. 6-3: GTE080 - Technical data

Technical data

6.1.4 GTE120

Transmission ratio	Symbol	Unit	one-stage					two-stage		
			i ⁶⁾	3	4	5	8	10	12	20
Maximum average drive speed at 50% T2N ⁵⁾ and S1 ¹⁰⁾	n _{m_max} 50%	min ⁻¹	3.350	3.400	3.500	3.500	3.500	3.500	3.500	3.500
Maximum average drive speed at 100% T2N ⁵⁾ and S1 ¹⁰⁾	n _{m_max} 100%	min ⁻¹	2.550	2.500	2.500	3.500	3.500	2.650	3.500	3.500
Max. input speed ⁵⁾	n _{in_max}	min ⁻¹	6.500	6.500	6.500	6.500	6.500	6.500	6.500	6.500
Max. output speed ⁵⁾	n _{out_max}	min ⁻¹	2.167	1.625	1.300	813	650	542	325	163
Nominal input torque ^{1) 7) 8)}	M _{in_nenn}	Nm	38.3	38.8	39.0	15.0	9.5	21.7	13.0	5.8
Nominal output torque ^{1) 7) 8)}	M _{out_nenn}	Nm	115	155	195	120	95	260	260	230
Nominal input torque ^{1) 7) 8) 9)}	M _{in_max}	Nm	61.3	62.0	62.4	24.0	15.2	34.7	20.8	9.2
Maximum input torque ^{1) 7) 8) 9)}	M _{out_max}	Nm	184	248	312	192	152	416	416	368
Backlash	Δφ	arcmin	< 7	< 7	< 7	< 7	< 7	< 9	< 9	< 9
Torsion-proof	D	Nm/ arcmin	12	12	12	12	12	13	13	13
Efficiency ⁴⁾	η	%	98	98	98	97	97	96	96	94
Moment of inertia ¹¹⁾	J	kg cm ²	2.63	1.79	1.53	1.32	1.3	2.56	1.5	1.3
Mass	m	kg	6	6	6	6	6	8	8	8
Lifetime	L _H		30.000							
Lubrication			Lifetime							
Gearbox housing temperature ²⁾	T _G	°C	-25 ... 90							
Sound pressure level ³⁾	L _P	dB(A)	65							
Degree of protection			IP54							

- 1) These values refer to a speed of the output shaft of n_{out} = 100 min⁻¹ on duty cycle K_A = 1 and S1-mode for electrical machines and T=30°C.
- 2) Referring to the middle of the housing surface
- 3) Sound pressure level in 1m distance; measured on drive speed of n_{in} = 3,000 min⁻¹ without load; i=5
- 4) Depends on ratio n_{out} = 100 min⁻¹
- 5) Allowed operating temperatures must be kept
- 6) Ratios (i= n_{out} / n_{in})
- 7) Depends on the motor shaft diameter
- 8) With key: for tumscent load
- 9) Permitted for 30,000 revolutions at the output shaft
- 10) See [Chapter 6.3 Thermal specifications for S1 operation](#)
- 11) The moment of inertia relates to the input shaft and to standard motor shaft diameter

Tab. 6-4: GTE120 - Technical data

6.1.5 GTE160

Transmission ratio	Symbol	Unit	one-stage				two-stage		
			i ⁶⁾	3	4	5	8	12	20
Maximum average drive speed at 50% T2N ⁵⁾ and S1 ¹⁰⁾	n_{m_max} 50%	min ⁻¹	1.350	1.450	1.650	2.150	1.550	2.050	2.950
Maximum average drive speed at 100% T2N ⁵⁾ and S1 ¹⁰⁾	n_{m_max} 100%	min ⁻¹	900	1.000	1.150	1.550	1.000	1.400	2.300
Max. input speed ⁵⁾	n_{in_max}	min ⁻¹	6.500	6.500	6.500	6.500	6.500	6.500	6.500
Max. output speed ⁵⁾	n_{out_max}	min ⁻¹	2.167	1.625	1.300	813	542	325	163
Nominal input torque ^{1) 7) 8)}	M_{in_nenn}	Nm	133.3	112.5	90.0	56.3	66.7	40.0	17.5
Nominal output torque ^{1) 7) 8)}	M_{out_nenn}	Nm	400	450	450	450	800	800	700
Maximum input torque ^{1) 7) 8) 9)}	M_{in_max}	Nm	213.3	180.0	144.0	90.0	106.7	64.0	28.0
Maximum input torque ^{1) 7) 8) 9)}	M_{out_max}	Nm	640	720	720	720	1280	1280	1120
Backlash	$\Delta\phi$	arcmin	< 6	< 6	< 6	< 6	< 10	< 10	< 10
Torsion-proof	D	Nm/ arcmin	38	38	38	38	41	41	41
Efficiency ⁴⁾	η	%	98	98	98	97	96	96	94
Moment of inertia ¹¹⁾	J	kg cm ²	12.14	7.78	6.07	4.63	12.37	6.65	5.28
Mass	m	kg	18	18	18	18	22	22	22
Lifetime	L_H		30.000						
Lubrication			Lifetime						
Gearbox housing temperature ²⁾	T_G	°C	-25 ... 90						
Sound pressure level ³⁾	L_P	dB(A)	70						
Degree of protection			IP54						

- 1) These values refer to a speed of the output shaft of $n_{out} = 100$ min⁻¹ on duty cycle $K_A = 1$ and S1-mode for electrical machines and $T=30^\circ\text{C}$.
- 2) Referring to the middle of the housing surface
- 3) Sound pressure level in 1m distance; measured on drive speed of $n_{in} = 3,000$ min⁻¹ without load; $i=5$
- 4) Depends on ratio $n_{out} = 100$ min⁻¹
- 5) Allowed operating temperatures must be kept
- 6) Ratios ($i = n_{out} / n_{in}$)
- 7) Depends on the motor shaft diameter
- 8) With key: for tumscent load
- 9) Permitted for 30,000 revolutions at the output shaft
- 10) See [Chapter 6.3 Thermal specifications for S1 operation](#)
- 11) The moment of inertia relates to the input shaft and to standard motor shaft diameter

Tab. 6-5: GTE160 - Technical data

6.2 Maximum transferable output torque

At $M_{out, nenn}$, Bosch Rexroth's planetary gearboxes are designed for high-cycle operation, in other words, if the application torques are always less than the nominal torque, no recalculation is necessary. However, it is possible to transfer higher application torques in the case of short torque peaks or long periods of intermittent duty. The following figure serves as guideline:

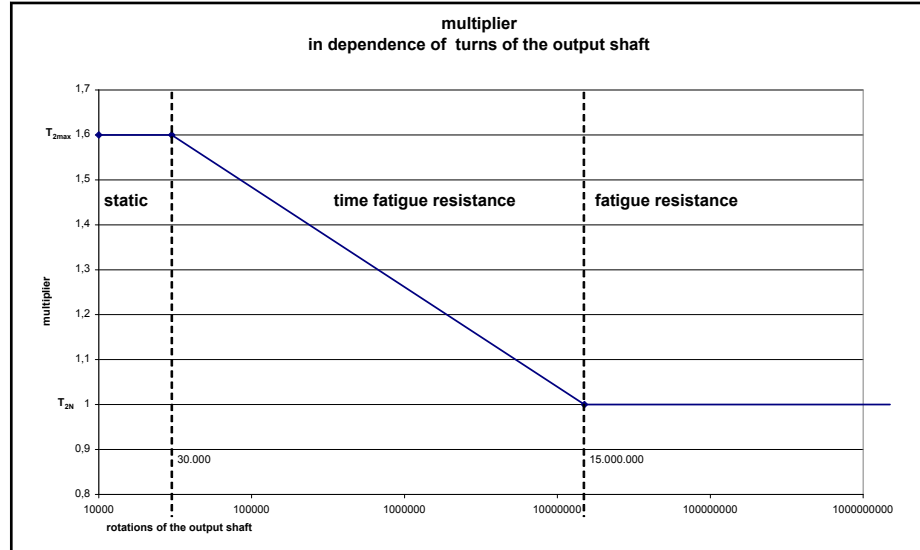

Fig. 6-1: Increase factor depending on the number of rotations of the output shaft

The maximum application torque must not exceed $1.6 \times M_{out, nenn}$. The number of rotations of the output shaft at the max. torque has to be calculated. If the number of rotations is larger than 15.000.000, the gearbox may only be subjected to the nominal torque of the gearbox. If the number of rotations is smaller than 15.000.000, the increase factor can be calculated by means of the following formula:

$$f = -0,1039 \times \ln\left(\frac{10^5}{30000} \times R\right) + 2,79$$

R Revolutions

Fig. 6-2: Formula increase factor

If $f > 1.6$, f is set to 1.6

If $f > 1.0$, f is set to 1.0

The maximum transferable moment $M_{out, max}$ of the gearbox is then calculated by means of $M_{out, max} = f \cdot M_{out, nenn}$.

the maximum application torque must not exceed the calculated maximum output torque of the gearbox.

$$M_{out, max} \leq M_{application}$$

6.3 Thermal specifications for S1 operation

Calculation of average speed:

$$n_m = \frac{n_1 \times t_1 + \dots + n_x \times t_x}{t_1 + \dots + t_x}$$

Fig. 6-3: Calculation mean speed

Assumed ambient conditions:

- Motor does not heat up the gearbox
- Plate size (square) = 2 x gearbox size
- Plate material: steel
- Convection it not impaired (no housing in the direct proximity of the gearbox)
- Ambient temperature: 30 °C
- Plate connection on machine bed: one-sided (30°C)

In the case of a required **output torque of 100%**:

Is n_m smaller than the nominal initial speed at 100% load, the gearbox is thermally suitable.

In the case of a required **output torque of 50%**:

Is n_m smaller than the nominal initial speed at 50% load, the gearbox is thermally suitable.



For the thermal design, observe the instructions under [chapter 4.2 "Selection" on page 18](#). If conditions are unfavorable, please reduce the speeds or consult Bosch Rexroth.

6.4 Technical data at increased lifetime

The technical data is based on a calculated gearbox-lifetime of $L_h = 30,000$ h. If a gearbox-lifetime of more than 30,000h is required, the technical data, regarding torque and speed have to be reduced by the following diagram.

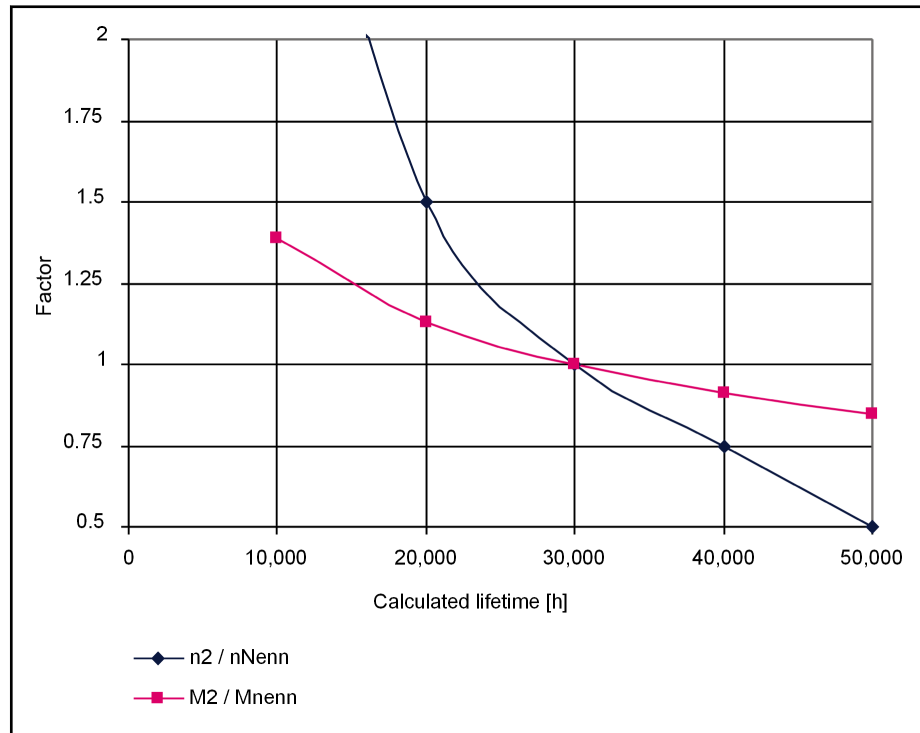

Fig. 6-4: Reduction of the technical data for increased lifetime



The permitted technical operating data may not be exceeded!

6.5 Limiting temperature curves to determine higher S1-speed

6.5.1 General

Special applications (e.g. printing sector) require higher S1-speed than given in the technical data. The GTE gearboxes fulfill these requirements at an accordingly reduced output torque individually for every gearbox size and ratio. The following limiting temperature curves are the basis. They are on trial determined thermal limiting characteristic curves which illustrate the possible operating points (S1-input speed/S1-output torque) at maximum thermal load of the gearbox (temperature increase 60K at 30°C environmental temperature) and unhindered air circulation.



The determined limiting characteristic curves are related on an ambient temperature of 30°C at unhindered air circulation and fastening on the steel flange, which is more than twice as wide as the gearbox and has a temperature of 30°C.

NOTICE

Overload of the gearbox due to exceeding the permitted gearbox housing temperature of 90°C.

During operation of motor/gearbox combinations in the selected operating point, please make sure that the permitted gearbox housing temperature of 90°C is not exceeded to avoid a gearbox overload. Depending from the gearbox or motor type, more or less heat is induced from the motor into the gearbox. For thermal inappropriate mounting it is recommended to check the permitted gearbox housing temperature after reaching the thermal steady-state.

6.5.2 GTE040

GTE040: Limiting temperature curves at $\Delta T = 60$ K

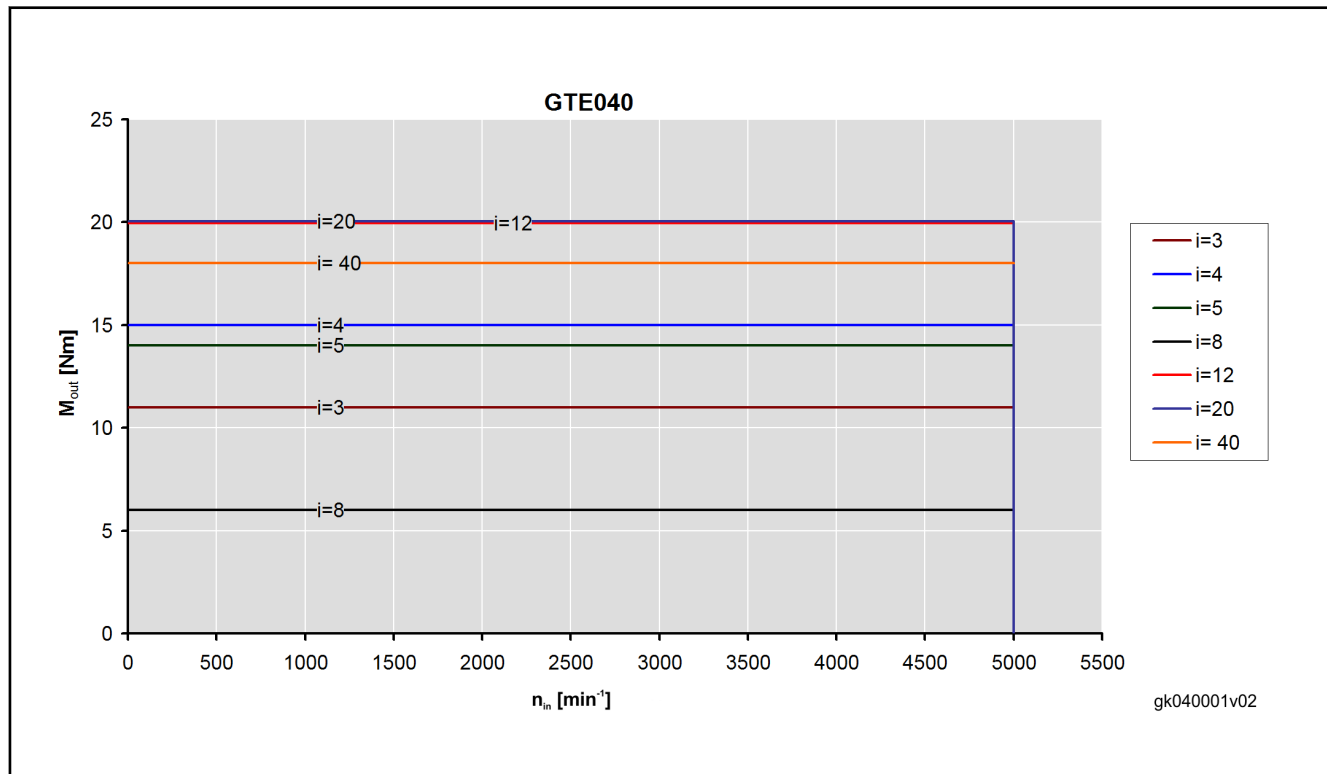

M_{out}

Output torque

n_{in}

Input speed

Fig. 6-5:

Ratio at limiting temperature curves GTE040

6.5.3 GTE060

GTE060: Limiting temperature curves at $\Delta T = 60$ K

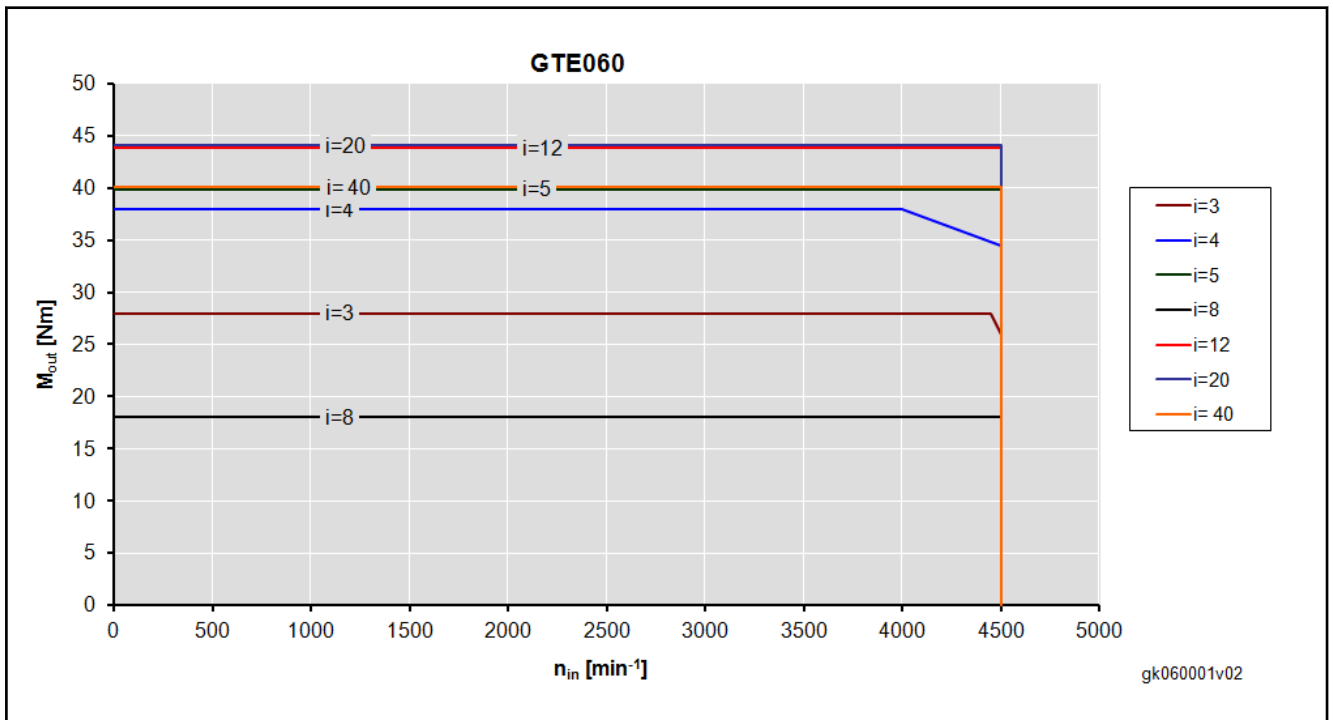

M_{out} Output torque
 n_{in} Input speed

Fig. 6-6: Ratio at limiting temperature curves GTE060

6.5.4 GTE080

GTE080: Limiting temperature curves at $\Delta T = 60$ K

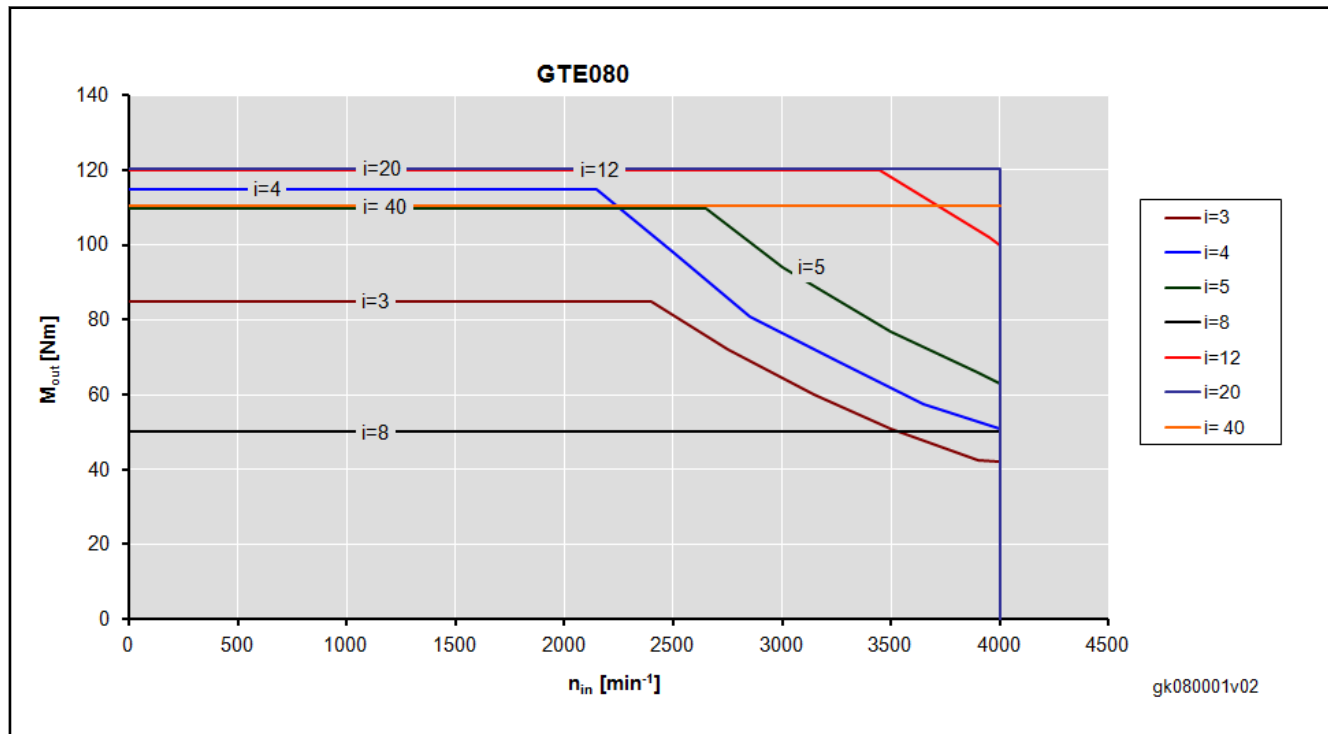

M_{out} Output torque
 n_{in} Input speed
Fig. 6-7: Ratio at limiting temperature curves GTE080

6.5.5 GTE120

GTE120: Limiting temperature curves at $\Delta T = 60$ K

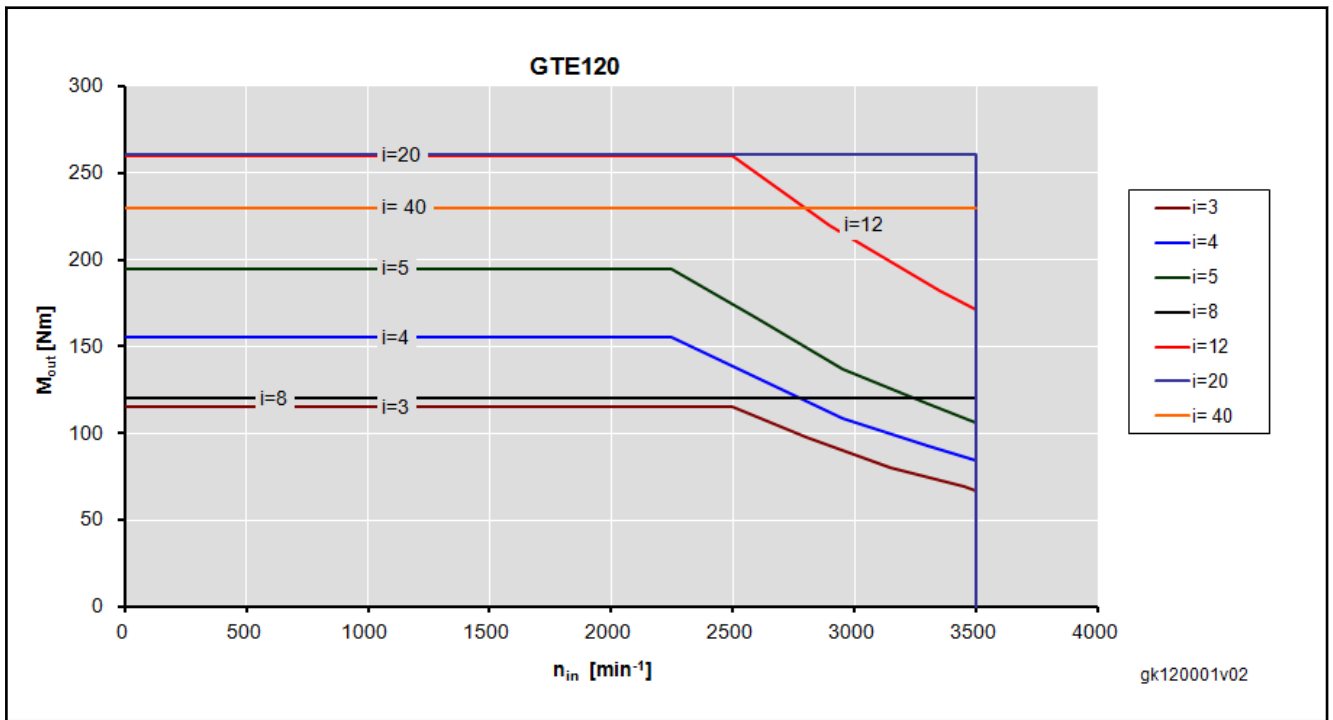

M_{out} Output torque
 n_{in} Input speed

Fig. 6-8: Ratio at limiting temperature curves GTE120

6.5.6 GTE160

GTE160: Limiting temperature curves at $\Delta T = 60$ K

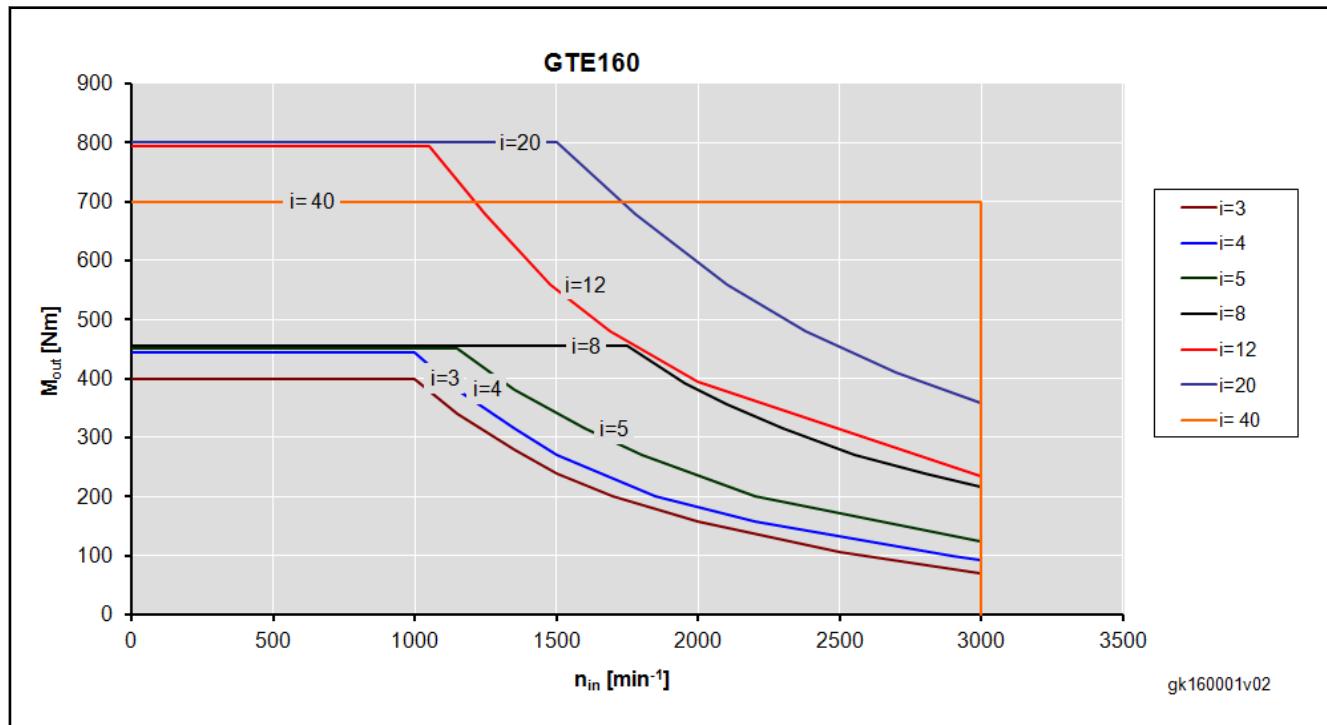

M_{out}

Output torque

n_{in}

Input speed

Fig. 6-9:

Ratio at limiting temperature curves GTE160

6.6 Permitted shaft load

6.6.1 General

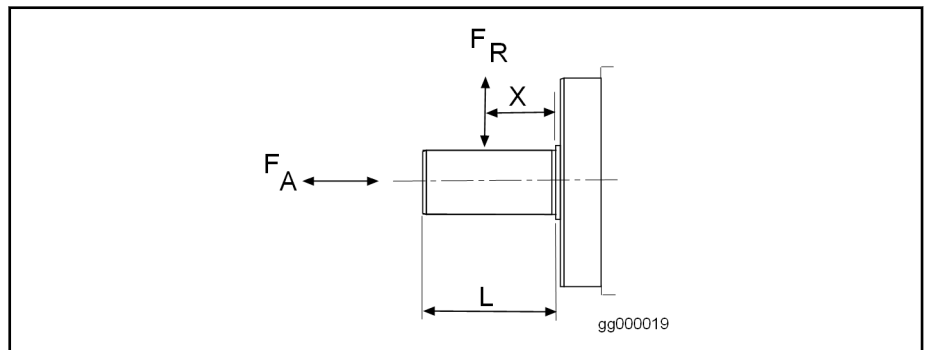

F_A	permissible axial force
F_R	permissible radial force
X	Distance between shaft shoulder on the output shaft and point of application of the radial force
n_{2m}	average output speed of the cycle

Fig. 6-10: permissible shaft load of the GTE

$$n_{2m} = \frac{n_{2a} \cdot t_a + n_{2b} \cdot t_b + \dots + n_{2n} \cdot t_n}{t_a + t_b + \dots + t_n}$$

Basis of design 30,000 operating hours nominal bearing lifetime L_{10h}

For radial forces F_{Ref} , which lie over the value of the diagram, decreases the nominal bearing lifetime as follows:

$$L_{10h} = 30000 \cdot \left(\frac{F_R}{F_{Ref}} \right)^3$$

F_R : Permitted radial force

F_{Ref} : Necessary radial force

6.6.2 GTE040

Permitted radial force

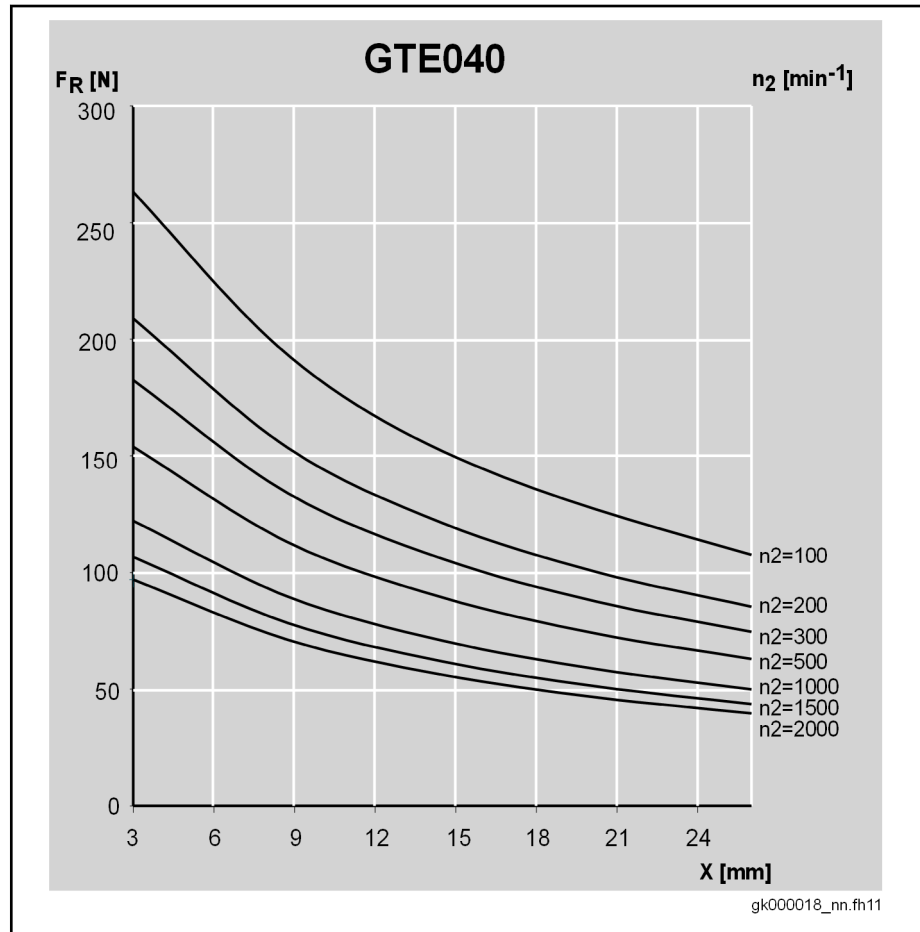

Fig. 6-11: Permitted radial force F_R GTE040

Permitted axial force $F_A < 160 \text{ N}$

F_A : Permitted axial force

F_R : Permitted radial force

Do occur higher axial forces, the bearing lifetime for this use has to be calculated individually.

6.6.3 GTE060

Permitted radial force

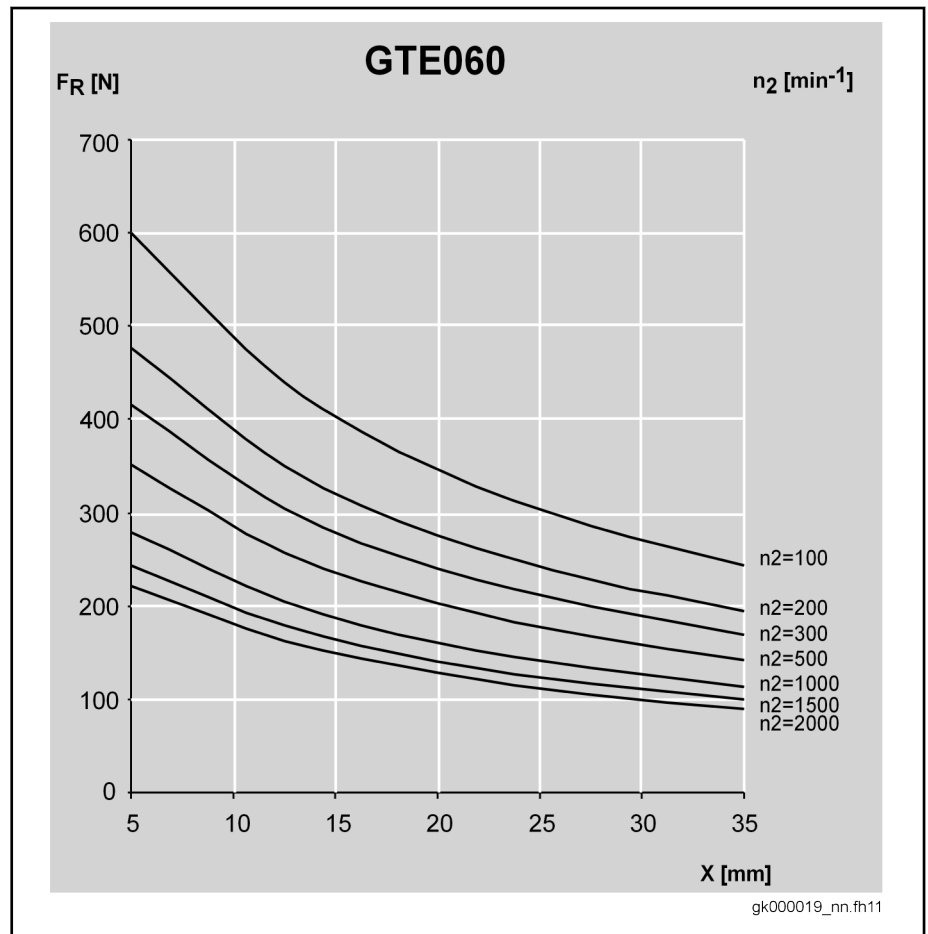

Fig. 6-12: Permitted radial force F_R GTE060

Permitted axial force $F_A < 450$ N

F_A : Permitted axial force

F_R : Permitted radial force

Do occur higher axial forces, the bearing lifetime for this use has to be calculated individually.

6.6.4 GTE080

Permitted radial force

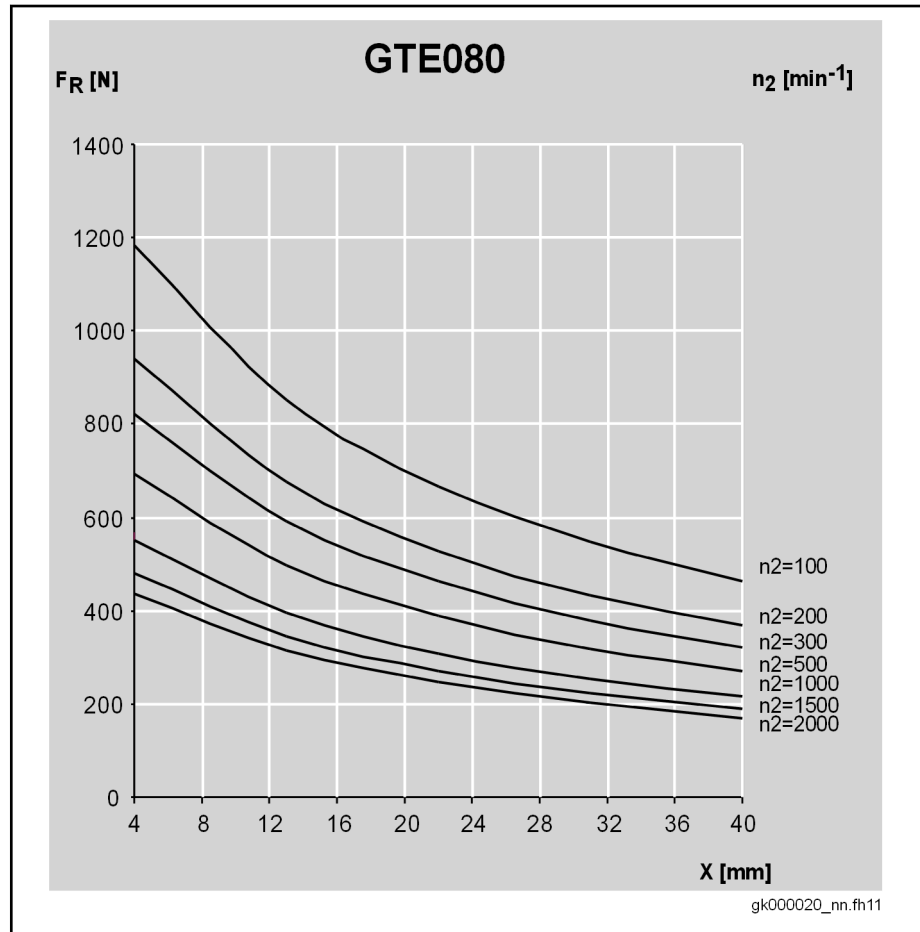

Fig. 6-13: Permitted radial force F_R GTE080

Permitted axial force $F_A < 900$ N

F_A : Permitted axial force

F_R : Permitted radial force

Do occur higher axial forces, the bearing lifetime for this use has to be calculated individually.

6.6.5 GTE120

Permitted radial force

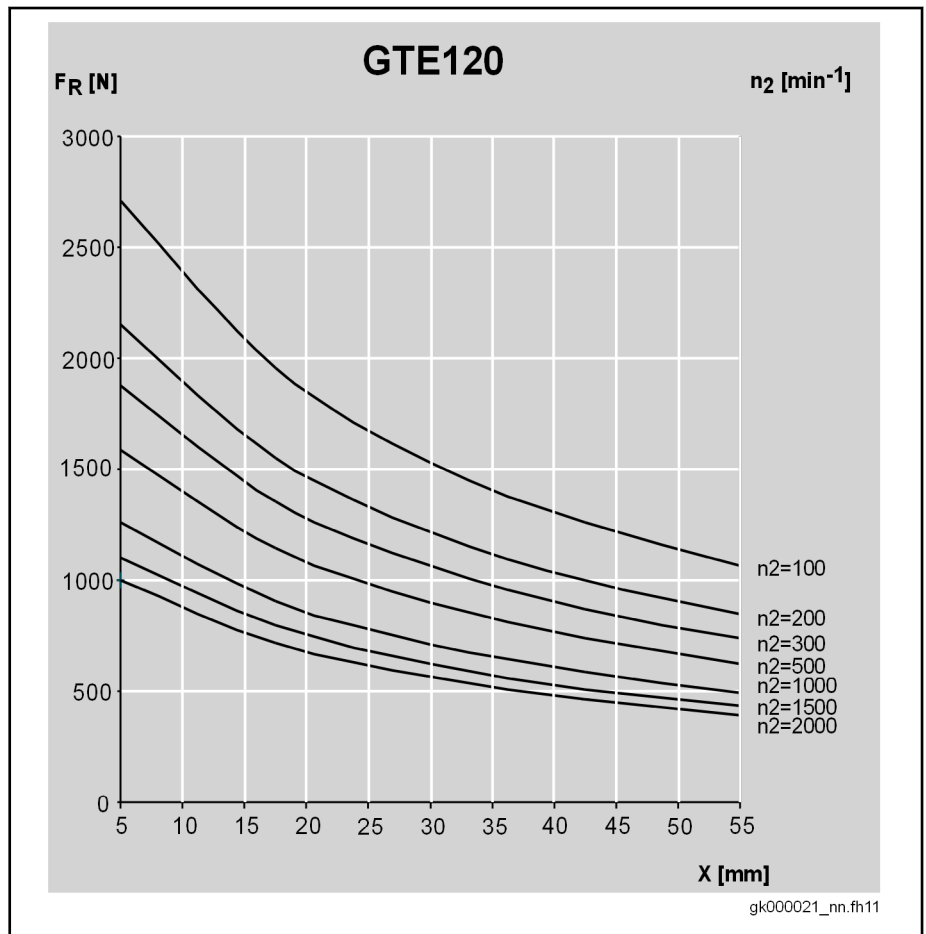

Fig. 6-14: Permitted radial force F_R GTE120

Permitted axial force $F_A < 2100 \text{ N}$

F_A : Permitted axial force

F_R : Permitted radial force

Do occur higher axial forces, the bearing lifetime for this use has to be calculated individually.

6.6.6 GTE160

Permitted radial force

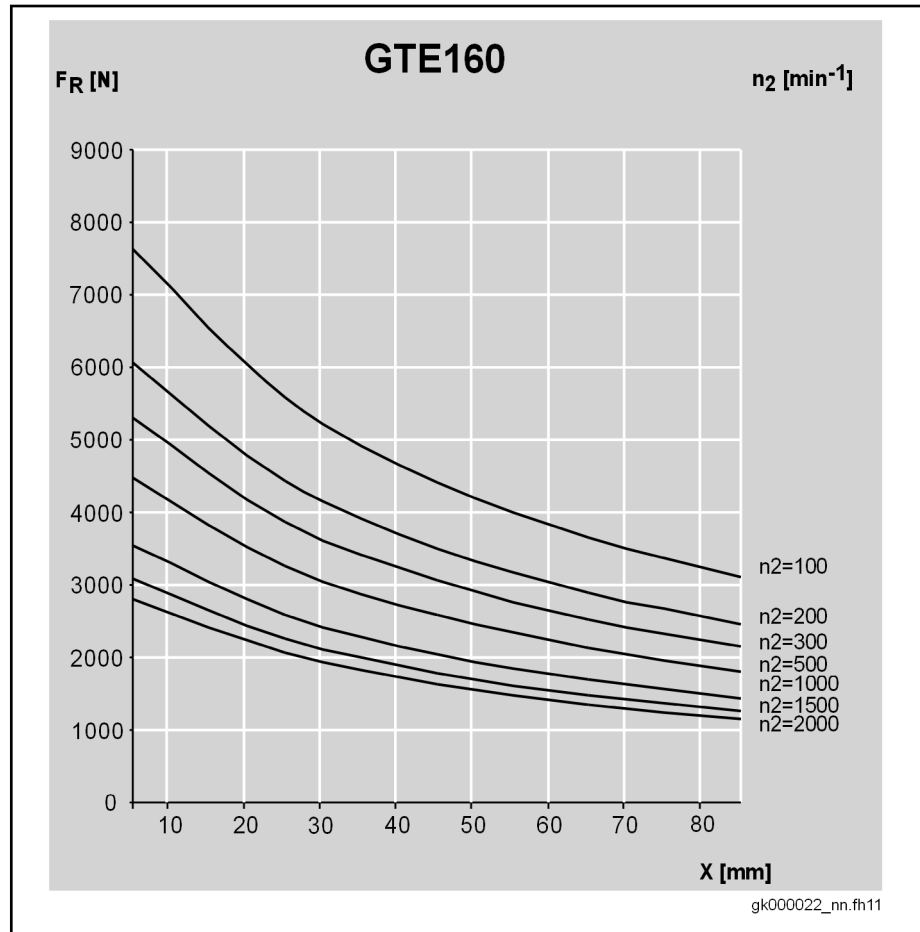

Fig. 6-15: Permitted radial force F_R GTE160

Permitted axial force $F_A < 6000$ N

F_A : Permitted axial force

F_R : Permitted radial force

Do occur higher axial forces, the bearing lifetime for this use has to be calculated individually.

7 Specifications

7.1 GTE040

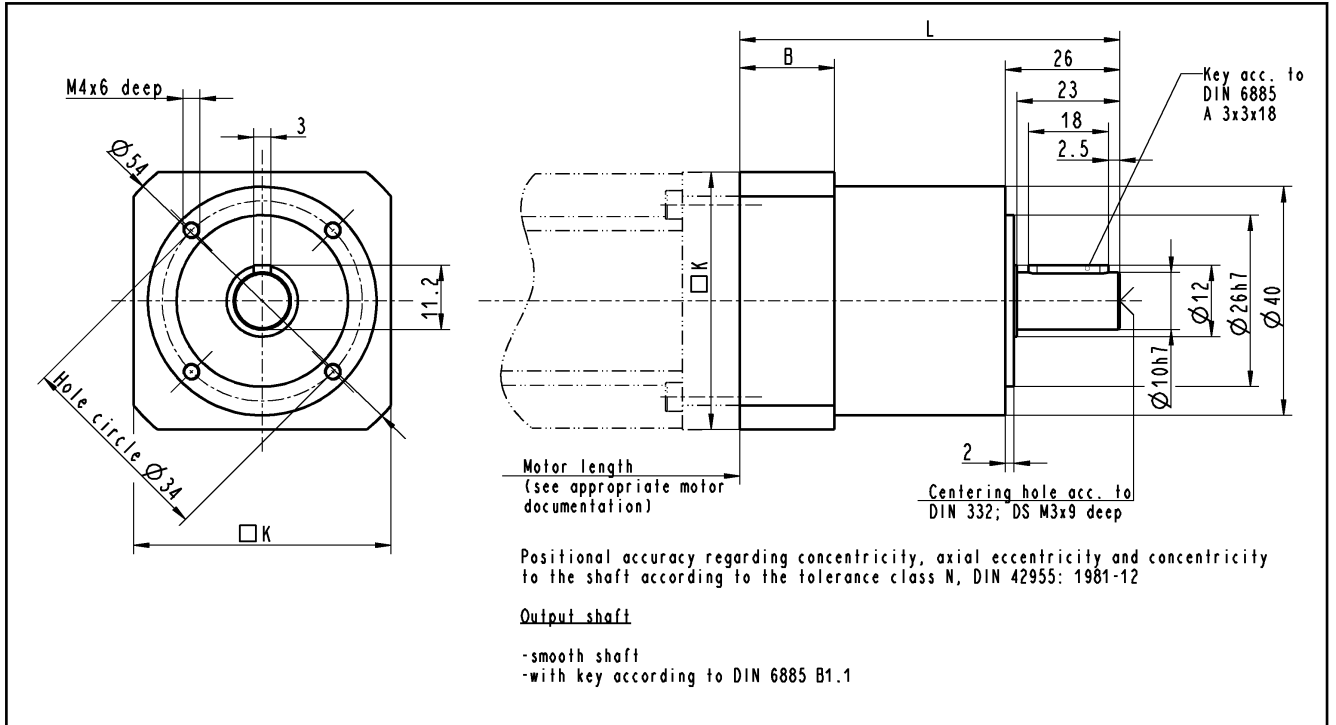

Fig. 7-1: Dimensional details GTE040, single and two-stage

Flanged motor type	One-stage		Two-stage		□ K ¹⁾ [mm]
	L [mm]	B [mm]	L [mm]	B [mm]	
MSM019A	93.5	28.5	106.5	28.5	40
MSM019B					

¹⁾ biggest flange size (motor/gearbox)

Tab. 7-1: Dimensional details GTE040, single and two-stage

Specifications

7.2 GTE060

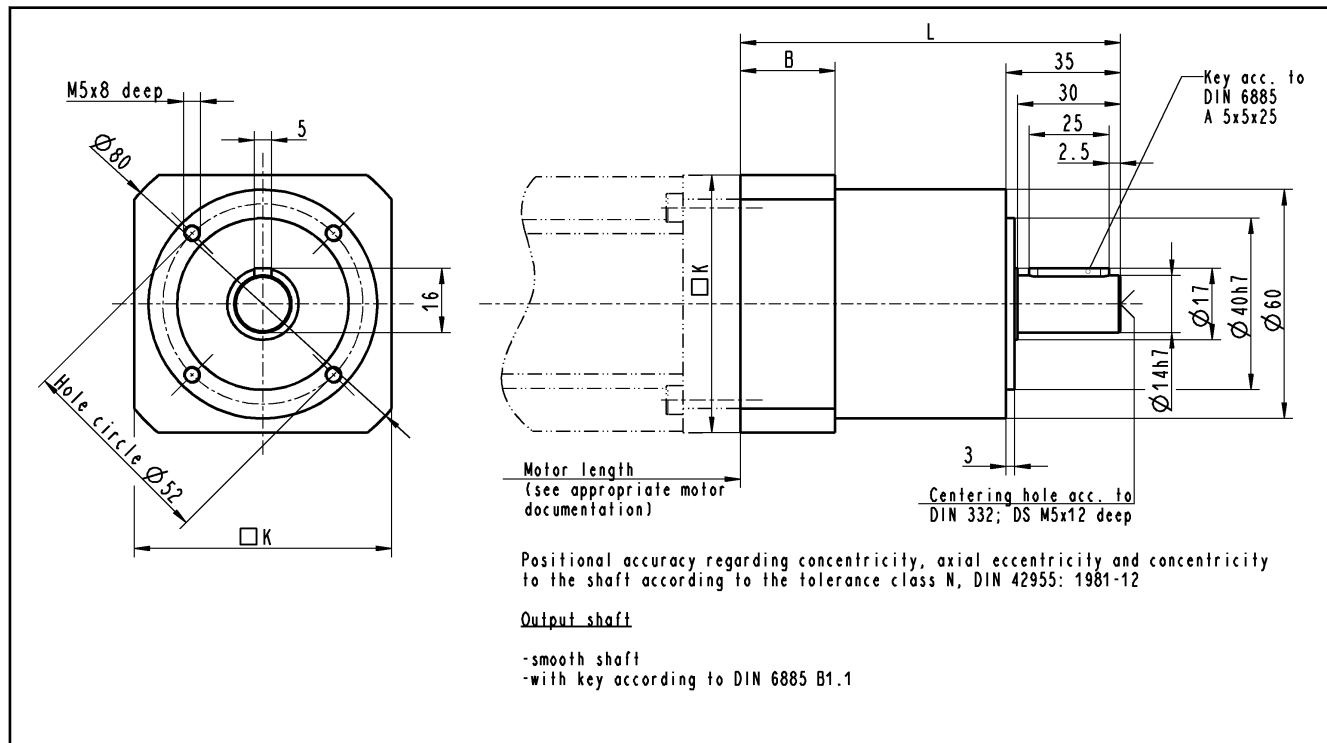

Fig. 7-2: Dimensional details GTE060, single and two-stage

Flanged motor type	One-stage		Two-stage		$\square K^{1)}$ [mm]
	L [mm]	B [mm]	L [mm]	B [mm]	
MS2N03-B	106	24.5	118.5	24.5	60
MS2N03-D	106	24	118.5	24	60
MSK030	106	24.5	118.5	24.5	60
MSM031B	113	31.2	125.5	31.2	60

¹⁾ biggest flange size (motor/gearbox)

Tab. 7-2: Dimensional details GTE060, single and two-stage

7.3 GTE080

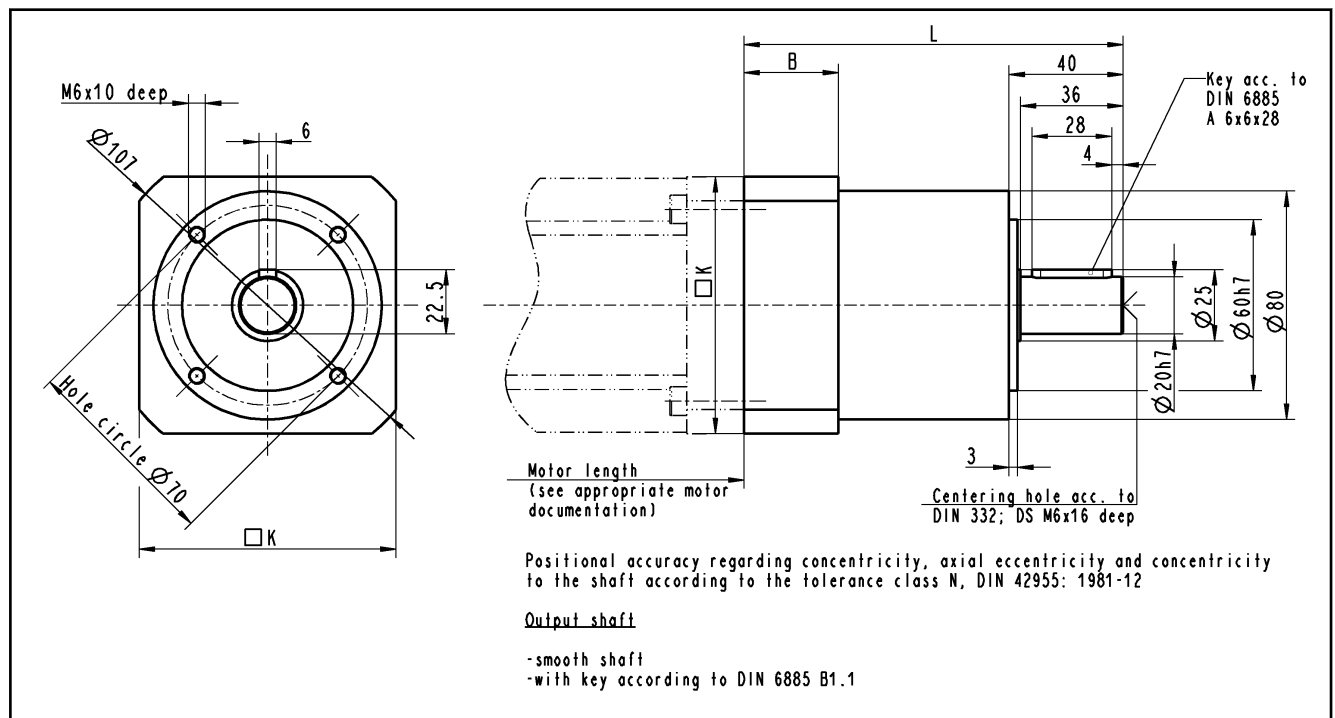

Fig. 7-3: Dimensional details GTE080, single and two-stage

Flanged motor type	One-stage		Two-stage		$\square K^{(1)}$ [mm]
	L [mm]	B [mm]	L [mm]	B [mm]	
MS2N03-B	134	33.5	151	33.5	80
MS2N03-D	134	33.5	151	33.5	80
MS2N04	134	33.5	151	33.5	90
MSK030	134	33.5	151	33.5	80
MSK040	134	33.5	151	33.5	90
MSK043	134	33.5	151	33.5	90
MSM031C	134	33.5	151	33.5	80
MSM041B	138.5	38.5	156	38.5	90
KSM041	134	33.5	151	33.5	90

¹⁾ biggest flange size (motor/gearbox)

Tab. 7-3: Dimensional details GTE080, single and two-stage

Specifications

7.4 GTE120

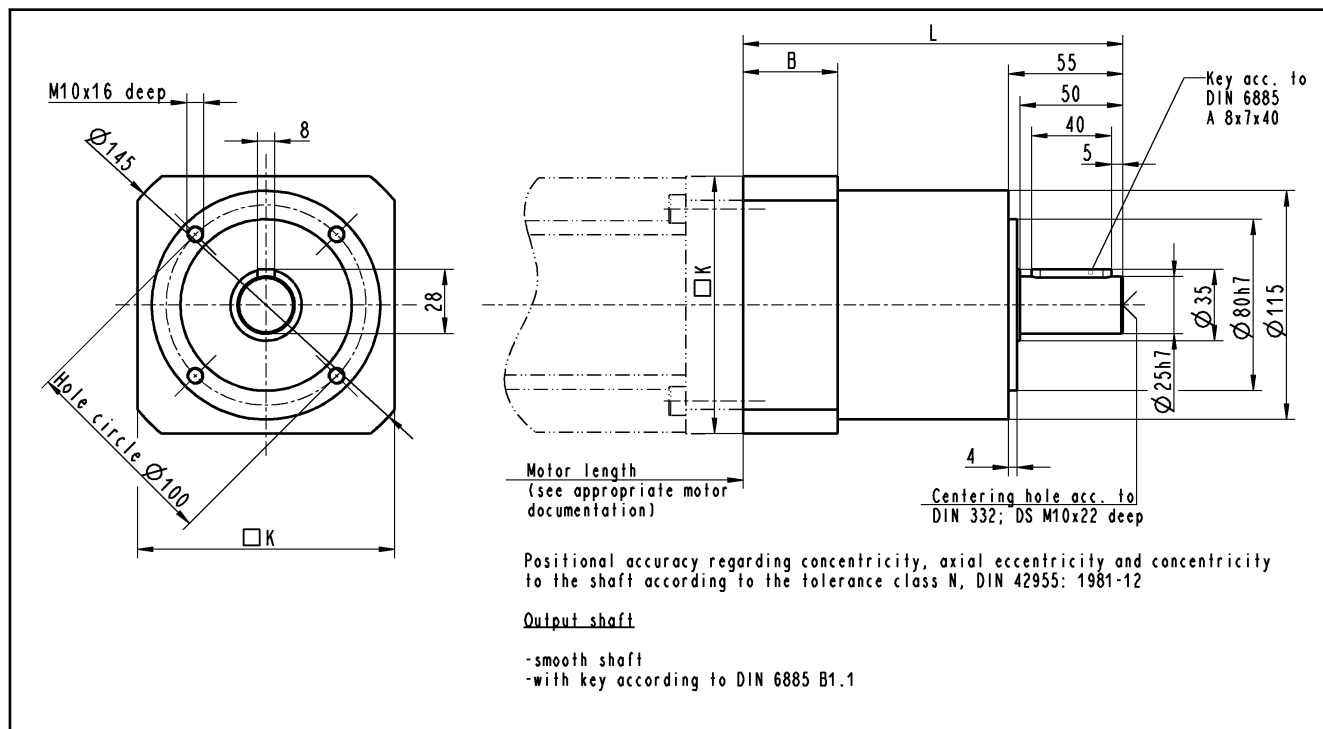

Fig. 7-4: Dimensional details GTE120, single and two-stage

Flanged motor type	One-stage		Two-stage		□ K ¹⁾ [mm]
	L [mm]	B [mm]	L [mm]	B [mm]	
MS2N04	176.5	47.5	203.5	47.5	115
MS2N05	176.5	47.5	203.5	47.5	115
MS2N06	186.5	57.5	-/-	-/-	116
MSK040	176.5	47.5	203.5	47.5	115
MSK043	176.5	47.5	203.5	47.5	115
MSK050	176.5	47.5	203.5	47.5	115
MSK060	186.5	57.5	-/-	-/-	115
MSK061	176.5	47.5	-/-	-/-	115
MSM041B	176.5	47.5	203.5	47.5	115
KSM041	176.5	47.5	203.5	47.5	115
KSM061	176.5	47.5	-/-	-/-	115

¹⁾ biggest flange size (motor/gearbox)

Tab. 7-4: Dimensional details GTE120, single and two-stage

7.5 GTE160

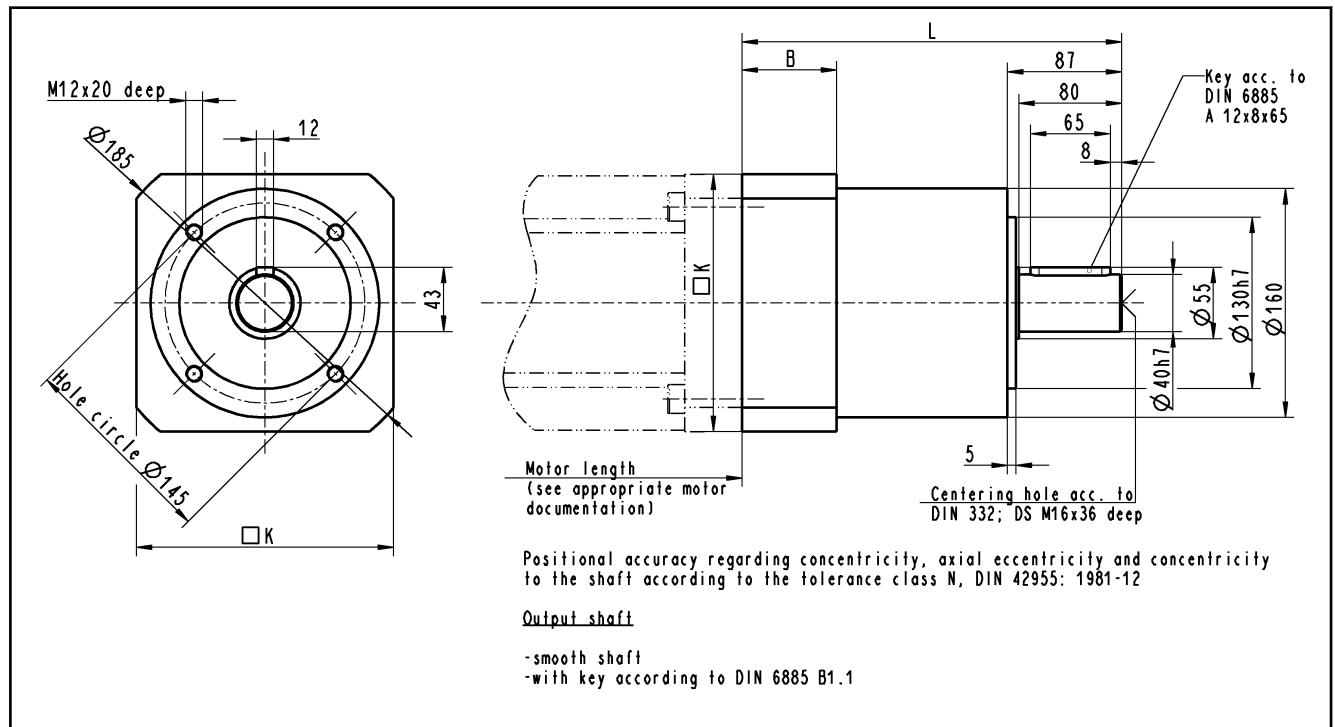

Fig. 7-5: Dimensional details GTE160, single and two-stage

Flanged motor type	One-stage		Two-stage		□ K ¹⁾ [mm]
	L [mm]	B [mm]	L [mm]	B [mm]	
MS2N05	255.5	64.5	305	64.5	140
MS2N06	255.5	64.5	305	64.5	140
MS2N07	263.5	72.5	313	72.5	140
MSK050	255.5	64.5	305	64.5	140
MSK060	255.5	64.5	305	64.5	140
MSK061	255.5	64.5	305	64.5	140
MSK070	263.5	72.5	313	72.5	140
MSK071	263.5	72.5	313	72.5	140
MSK075	263.5	72.5	313	72.5	140
MSK076	255.5	64.5	305	64.5	140
MSK100	265.5	74.5	-/-	-/-	190
KSM061	255.5	64.5	305	64.5	140
KSM071	263.5	72.5	313	72.5	140
KSM076	255.5	64.5	305	64.5	140

¹⁾ biggest flange size (motor/gearbox)

Tab. 7-5: Dimensional details GTE160 gearboxes, one and two-stage

8.2 Type code GTE060

Type short description	1	2	3	4	5	6	7	8	9	1	2	3	4	5	6	7	8	9	2	1	2	3	4	5	6	7	8	9	3	1	2	3	4	5	6	7	8	9	4
Example:	G	T	E	0	6	0	-	N	N	1	-	0	0	4	A	-	N	N	4	2																			

01	Product	GTE = GTE
02	Size	060..... = 060
03	Mounting position, operating mode	Arbitrary = NN
04	Stages	One-stage..... = 1 Two-stage..... = 2
05	Transmission ratio	One-stage: 3 4 5 8 10 e.G. 4:1.....= 004 Two-stage: 12 20 40 e.G. 20:1.....= 020
06	Output shaft and reduced backlash	With key = A Plain..... = B
07	Designation of mounted motor	

Motor		Gearbox GTE060
MS2N	03-B	NN02
	03-D	NN50
MSK	030	NN02
MSM	031B	NN42

Fig. 8-2: Type code DCCS-40019-060_NOR_N_DE_2016-06-21

8.3 Type code GTE080

Type short description	1	2	3	4	5	6	7	8	9	1	2	3	4	5	6	7	8	9	2	3	4	5	6	7	8	9	0	1	2	3	4	5	6	7	8	9	0
Example:	G	T	E	0	8	0	-	N	N	1	-	0	0	4	A	-	N	N	4	2																	

01 Product
GTE = GTE

02 Size
080..... = 080

03 Mounting position, operating mode
Arbitrary = NN

04 Stages
One-stage..... = 1
Two-stage..... = 2

05 Transmission ratio
One-stage: 3 4 5 8 10 e.G. 4:1.....= 004
Two-stage: 12 20 40 e.G. 20:1.....= 020

06 Output shaft and reduced backlash
With key = A
Plain..... = B

07 Designation of mounted motor

Motor		Gearbox
		GTE080
MS2N	03-B	NN02
	03-D	NN50
	04	NN03
MSK	030	NN02
	040	NN03
	043	NN03
MSM	031C	NN43
	041B	NN44
KSM	041	NN03

Fig. 8-3: Type code DCCS-40019-080_NOR_N_DE_2016-07-07

8.4 Type code GTE120

Type short description	1	2	3	4	5	6	7	8	9	1	2	3	4	5	6	7	8	9	2	1	2	3	4	5	6	7	8	9	3	1	2	3	4	5	6	7	8	9	4	1	2	3	4	5	6	7	8	9
Example:	G	T	E	1	2	0	-	N	N	1	-	0	0	4	A	-	N	N	4	2																												

01 Product
GTE = GTE

02 Size
120 = 120

03 Mounting position, operating mode
Arbitrary = NN

04 Stages
One-stage = 1
Two-stage = 2

05 Transmission ratio
One-stage: 3 4 5 8 10 e.G. 4:1 = 004
Two-stage: 12 20 40 e.G. 20:1 = 020

06 Output shaft and reduced backlash
With key = A
Plain = B

07 Designation of mounted motor

Motor		Gearbox
Motor		GTE120
MS2N	04-x	NN03
	05-x	NN20
	06-x	NN21 (1)
MSK	040	NN03
	043	NN03
	050	NN20
	060	NN21 (1)
	061	NN05 (1)
MSM	041B	NN44
KSM	041	NN03
	061	NN05 (1)

1) Ready-mounted ex works, only deliverable with single-stage gearbox

Fig. 8-4: Type code DCCS-40019-120_TCO_N_DE_2017-05-30

8.5 Type code GTE160

Type short description	1	2	3	4	5	6	7	8	9	1	2	3	4	5	6	7	8	9	2	3	4	5	6	7	8	9	0	1	2	3	4	5	6	7	8	9	0
Example: GTE160 - NN1 - 004A - NN42	G	T	E	1	6	0	-	N	N	1	-	0	0	4	A	-	N	N	4	2																	

01 Product
GTE = GTE

02 Size
160..... = 160

03 Mounting position, operating mode
Arbitrary = NN

04 Stages
One-stage..... = 1
Two-stage..... = 2

05 Transmission ratio
One-stage: 3 4 5 8 e.G. 4:1.....= 004
Two-stage: 12 20 40 e.G. 20:1.....= 020

06 Output shaft and reduced backlash
With key = A
Plain..... = B

07 Designation of mounted backlash

Motor		Gearbox
		GTE160
MS2N	05-x	NN20
	06-x	NN21
	07-x	NN16
MSK	050	NN20
	060	NN21
	061	NN05
	070	NN16
	071	NN16
	075	NN16
	076	NN06
	100	NN09 (1)
KSM	061	NN05
	071	NN16
	076	NN06

1) Ready-mounted ex works, only deliverable with single-stage gearbox

Fig. 8-5: Type code DCCS-40019-160_NOR_N_DE_2016-07-07

9 Handling, transport and storage

9.1 Handling

9.1.1 Identifying the goods

Transport documents The total scope of a delivery can be seen in the delivery note or waybill. However, the contents of a delivery can be distributed over several packages.

Barcode label Each motor package is provided with a bar code label providing the following data:

- Type designation
- Customer
- Delivery note number
- Consignment

The bar code label is provided for identification of the contents during processing of the order.

9.1.2 Name plates

Gearboxes The gearbox is delivered with a name plate. The name plate is attached to the gearbox-housing. The name plate was extended by a 2D-barcode to improve the read-in via barcode scanner and to have an additional possibility to read in.

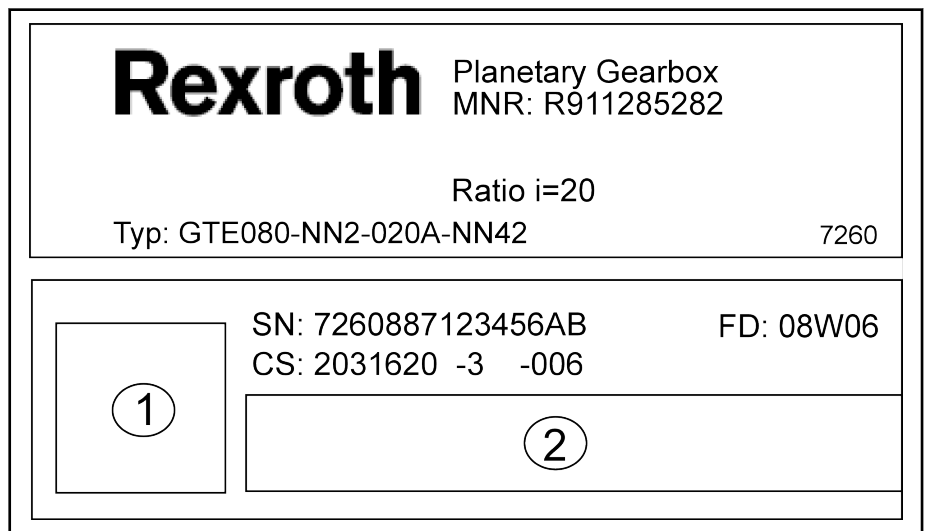

- 1 2D - Barcode
2 Barcode

Fig. 9-1: Name plate (example GTE gearbox)

Motor-gearbox combination

The motor is delivered with its own separate type plate. This is attached to the motor housing. In addition, a second type plate is attached using two-side tape onto the original motor name plate. The second type plate can be attached where visible on the machine, if the original type plate of the motor is concealed by parts of the machine. Because of different national regulations, different type plates are used for motors according to EN and UL-standards. The differences are shown in the following picture.

The type plate is provided for

- identification of the motor

- procurement of spare parts in case of a fault
- service information

9.2 Transport and storage

CAUTION

Damage or injuries and invalidation of the warranty due to improper handling!

- ⇒ Avoid mechanical stressing, throwing, tipping or dropping of the products.
- ⇒ Use suitable lifting equipment only.
- ⇒ Never lift up the motor on the optional fan housing.
- ⇒ Use suitable protective equipment and protective clothing during transport; wear safety shoes.
- ⇒ Protect the products from dampness and corrosion.

Gearboxes Also observe the notes regarding storage and transport on the packages

The gearboxes are typically supplied in recyclable cardboard boxes with carton for shaped elements.

It is recommended to store the gearboxes in their original packaging in a horizontal position until they are ready for use. The permissible temperature range for short-term storage or transport is -20°C up to $+80^{\circ}\text{C}$.

For long-term storage, it is recommended to store the gearboxes in a dry environment with temperatures from 0°C to $+30^{\circ}\text{C}$. The gearboxes can be stored over a period of maximum 2 years under these conditions.

Avoid direct insolation, UV light and ozone because it leads to deterioration of the sealants.

We recommend using a FIFO system - "First-in, first-out".



Remove all the anticorrosive on the gearboxes before mounting them.

The GTE gearboxes are filled-for-life with lubrication and are ready for use. The input and output are treated with anticorrosive coating.

NOTICE

Do not proceed cleaning via air pressure!

The danger consists that overpressure within the gearbox can occur which negatively influences the function and lifetime of the gearbox.

Motor-gearbox-combination

The following conditions must be kept during transport and handling:

- Use the appropriate means for transport. Take the weight of the components into consideration (weights are specified in the appropriate "Technical Data" chapters of the various motors and gearboxes and/or on the type label of the motor).
- Transport the motor-gearbox combination only in the horizontal position.
- To lift the motor-gearbox combinations use a crane and lifting sling belts
- Avoid damage to the motor flange and drive shaft.
- Avoid impacts on the gearbox drive shaft.
- Remove the protective cover on the gearbox output shaft just before mounting.

NOTICE**Motor or gearbox damage and guarantee loss due to incorrect storage!**

The following conditions must be kept during storage:

- Permissible range of temperature: -20°C to $+80^{\circ}\text{C}$ (only valid for short-term storage or transport. For a long-term storage please keep a temperature range of 0°C to $+30^{\circ}\text{C}$.)
- Store motors in dry places which are free from dust and vibrations.
- Store motors horizontally.
- Do not remove the plastic protective sleeve on the output shaft. It protects the shaft from moisture, rust and mechanical damage.

10 Assembly

10.1 Skilled personnel

Any work on the system, on the drives, or on the planetary gearboxes or in their vicinity may only be carried out by properly skilled personnel. The owner of the system must ensure that all persons carrying out

- installation works
- maintenance, or
- operating activities

on the system are adequately familiar with the contents of this documentation as well as with all warnings and precautionary measures contained therein. Qualified skilled personnel are defined as those who have been trained, instructed or are authorized to activate and deactivate, ground and mark electric circuits and equipment according to the technical safety regulations. Qualified technical personnel must possess appropriate safety equipment and have been trained in first aid.

10.2 Motor mounting

10.2.1 General Information

The motor is centered by using pilot diameter of the Bosch Rexroth motor and the appropriate pilot diameter of the gearbox's input flange. The connection between the motor output shaft and gearbox input shaft is established via a compression coupling. The compression couplings are matched to the corresponding motor shaft diameters when necessary by using a slotted bushings. Slotted distance bushings are used with small motor shafts in order to compensate for the difference in diameter compared to the gear box clamping hub. The clamping connection of the GTE gearboxes present an innovation, which makes a high exactness at assembly possible. The tension results from several closed slots, whereby a precise cylindrical clamping can be reached. The position of clamping ring, bush and motor shaft is irrelevant for assembly.

Before mounting the servo motors to the gearboxes, all parts have to be checked closely for damage. All parts should slide easily and without any force into one another. Damage on the motor drive shaft or to the compression coupling of the gearbox can prevent this and must be avoided.



Every warranty claim expires, if adapter parts are removed or altered.

Damage to or contamination on the motor front flange face or on the gearbox flange face can lead to angular offset of the motor drive shaft and the gearbox. This can lead to stress on the connection and will have a negative influence on the noise and life time of the motor and/or the gearbox.

The gearboxes are provided with the proper adapter parts necessary for the stipulated motor type according to the type code in the order. Adapter parts makes it possible for the gearboxes to be mounted on every Bosch Rexroth servo motor listed in the type code.



When combining Bosch Rexroth motors with GTE gearboxes, always choose motors with **smooth shafts**.

10.2.2 Mounting procedure

If the gearbox and motor have been checked on their quality, the following assembly procedure is recommended.

1. Clean and check the parts.

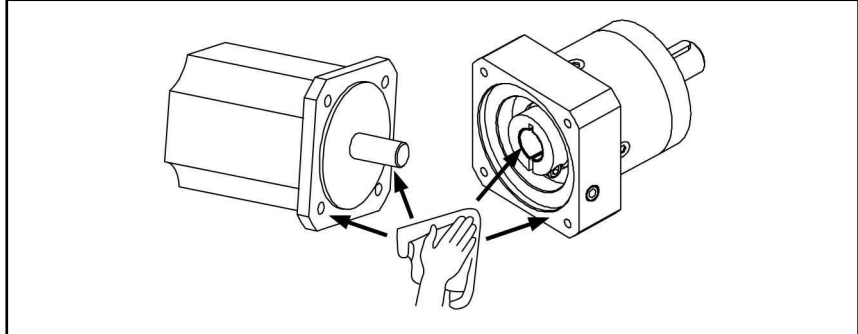

Fig. 10-1: *Cleaning of the parts before mounting*

Check for damage to the motor shaft, compression coupling bore and any bushing, as well as the faces of motor and gearbox flanges and clean them free from grease thoroughly. Do not clean the parts with compressed air. Avoid using aggressive detergents, which could damage the seals.

2. Remove cap screws.

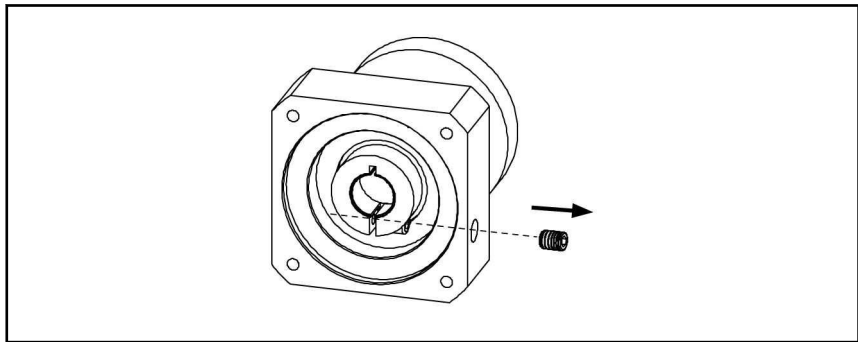

Fig. 10-2: *Remove the cover screws*

Remove the cover screws from the gearbox connection flange, which covers the access to the clamping screw. Turn the compression coupling so that the heads of the clamping screws line up with the tapped holes, which have now been opened in the gearbox's adapter plate.

3. Insert the motor shaft into the gearbox

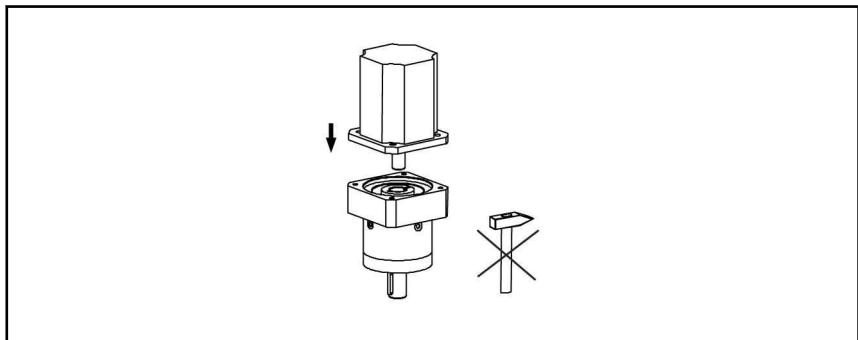

Fig. 10-3: *Insert the motor shaft into the gearbox*

Insert the motor shaft into the gearbox coupling until the gearbox's connecting flange and the motor face are fully in contact. It should be possible to accomplish this without excessive force. The gearbox is equip-

ped with an integrated thermal length compensation to compensate for the thermal expansion of the motor shaft. This compensates the linear extension of the motor drive shaft at temperature rise. When joining the parts together can only be done with high power, high forces occur on the clamping hubs or the motor bearing, which lead to damage on the motor and / or the gearbox.



If so, please contact your responsible sales office immediately.

NOTICE

Danger of damaged motor bearing and / or gearbox due to bracing during mounting.

Do the assembly process in vertical position.

4. Connect the motor to the gearbox

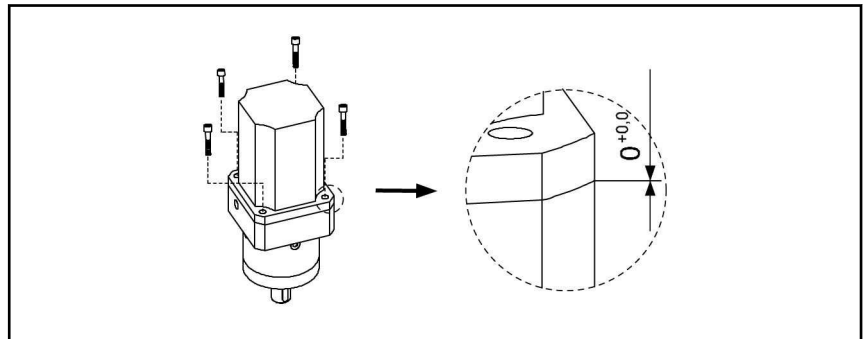

Fig. 10-4: Tighten the motor fastening screws (crossed)

Use screws with property class 8.8. The screws must be locked. The screws must be tightened crossed with the respectively correct torque according to DIN to assure a proper connection of the gearbox with the motor.

5. Reinsert the cap screws.

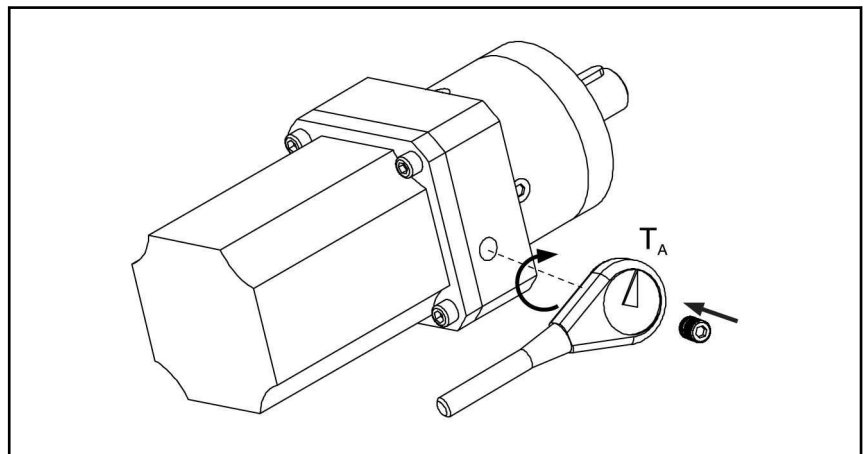

Fig. 10-5: Tightening torque – cap screws

The cap screws must be replaced and tightened with the specified torque (see Fig. 10-5). To ensure an IP54 sealed drive-system, the cap screws (as described in step 2) have to be re-tightened.

Gears	GTE040		GTE060	GTE080	GTE120	GTE160
	≤ 8	>8				
shaft diameter	≤ 8	>8	≤ 14	≤ 19	≤ 24	≤ 35
T _A [Nm]	2	4.5	4.5	9.5	16.5	40
SW [mm]	2.5	3	3	4	5	6

Tab. 10-1: Tightening torque

10.3 Gearbox mounting

Remove the protective cap from the gearbox shaft and thoroughly clean the pilot diameter, the contact surface and the output shaft.

Furthermore,

Mounting of the gearbox to the machine (or robot, etc.) is to be made via the output pilot diameter of the gearbox and four through holes on the gearbox housing.

We recommend using ISO 12.9-grade bolts with the proper tightening torques. We also recommend securing the bolts with Loctide.

Gearbox type	Pilot diameter	Bolt size- ISO-grade	Tightening torque
	[mm]		[Nm]
GTE040	26	M4-12.9	5.3
GTE060	40	M5-12.9	10.4
GTE080	60	M6-12.9	18
GTE120	80	M10-12.9	87
GTE160	130	M12-12.9	150

Tab. 10-2: Flange-mounting data for installing the gearbox on the machine.

Assure a non-distorted mount when installing the gearbox. Attachments part, like gears or tooth lock washers have to be mounted on the output shaft non-violent. In no case, they should be mounted by beating. Use only appropriate tools or appliances.



To avoid a heat accumulation and therewith the danger of an over-temperature disconnection within the drive-system (gearbox + motor), make sure that during operation an unhindered circulation of air exists.

11 Commissioning, operation and maintenance

11.1 Start-up

11.1.1 General information

The following commission notes refer to the GTE planetary gearboxes as part of a drive-system with motor, drive and control unit.

11.1.2 Preparation

1. Keep the documentation of all products you are using ready.
2. Log all measures taken in the commissioning log.
3. Check the products for damage.
4. Check all mechanical and electrical connections.
5. Activate the safety and monitoring equipment of the system.

NOTICE

Damage to property due to errors in the controls of motors and moving elements! Unclear operating states and product data!

- Do not carry out commissioning if connections, operating states or product data are unclear or faulty!
- Do not carry out commissioning if the safety and monitoring equipment of the system is damaged or not in operation.
- Damaged products must not be put into operation.
- Contact Bosch Rexroth for missing information or support during commissioning!

11.1.3 Bulk head connector

When all requirements are met, proceed as follows:

1. Commission the motors, controllers and power supplies according to the corresponding descriptions. Note the respective product documentation.
2. Before releasing the setpoint, check whether the set relationship of the maximum motor speed and the preset setpoint corresponds to the specifications for the machine.
3. At a low turning speed, check whether the rotation direction of the gearbox and the polarity setpoint correspond to the specifications for the machine.
4. At a low turning speed, check whether the positioning commands of the control systems are executed correctly.
5. Log all measures taken in the commissioning report.

When all steps have been executed correctly, commissioning of the gearbox is complete.



Commissioning of motors and controllers may require additional steps. The inspection of the functioning and performance of the systems is not part of the commissioning of the gearbox; instead, it is carried out within the framework of the commissioning of the machine as a whole. Observe the instructions and regulations given by the machine manufacturer.

11.2 Deactivation

In the case of malfunctions, maintenance measures or to deactivate the gearbox-motor unit, proceed as follows:

1. Observe the instructions of the machine documentation.
2. Use the machine-side control commands to bring the drive to a controlled standstill.
3. Switch off the power and control voltage of the drive device.
4. Switch off the motor protection switch for the motor fan.
5. Switch off the main switch of the machine.
6. Secure the machine against accidental movements and against unauthorized operation.
7. Wait for the discharge time of the electrical systems to expire and then disconnect all electrical connections.
8. Before dismantling, secure the gearbox-motor unit and supply cables against falling or movements before disconnecting the mechanical connections.
9. Document all done measures in the start-up report and machine maintenance plan.

11.3 Disassembly

DANGER

Fatal injury due to errors in trigger motors and moving elements!

- Do not work on unsecured and operating machines.
- Secure the machine against accidental movements and against unauthorized operation.
- Before dismantling, secure the gearbox-motor unit and supply cables against falling or movements before disconnecting the mechanical connections.

1. Observe the instructions of the machine documentation.
2. Please heed the safety notes and carry out all steps as described in the anterior instructions in the chapter "11.2 Deactivation".
3. Remove the gearbox-motor unit from the machine and store the unit properly.
4. Document all executed measures in the commissioning report or in the machine maintenance plan.

11.4 Maintenance

11.4.1 General information

Planetary gearboxes of GTE series operate without deterioration within the given operating conditions. However, operation under unfavorable conditions can lead to limitations in availability.

- Observe the information of the machine manufacturer in the machine maintenance plan.
- Log all maintenance measures in the machine maintenance plan.

11.4.2 Measures

⚠ WARNING

**Danger of injury due to moving elements!
Danger of injury due to hot surfaces!**

- Do not carry out any maintenance measures, while the machine is running.
- This work must be carried out only by skilled personnel.
- During maintenance work, secure the system against restarting and unauthorized use.
- Do not work on hot surfaces.
- Protect open supply cables and connections against penetration of pollution.

Bosch Rexroth recommends the following maintenance measures, based on the maintenance plan of the machine manufacturer:

Measure	Interval
Check the mechanical and electrical connections.	According to the guidelines in the machine maintenance plan, but at least every 1,000 operating hours.
Check the gearbox-motor unit for smooth running, vibrations and bearing noises.	According to the guidelines in the machine maintenance plan, but at least every 1,000 operating hours.
Remove dust, chips and other dirt from the gearbox-motor housing, cooling fins and the connections.	Depending on the degree of soiling, but after 6 month operation at the latest. Do it monthly at strong pollution.

Tab. 11-1: Gearbox-motor unit maintenance plan

11.5 Troubleshooting

11.5.1 General information

⚠ WARNING

**Danger of injury due to moving elements!
Danger of injury due to hot surfaces!**

- Do not carry out any maintenance measures, while the machine is running.
- This work must be carried out only by skilled personnel.
- During maintenance work, secure the system against restarting and unauthorized use.
- Do not work on hot surfaces.
- Protect open supply cables and connections against penetration of pollution.

11.5.2 Excess temperature of gearbox housing

Status	The housing temperature of the gearbox climbs to unusually high values.
Possible causes	<ol style="list-style-type: none"> 1. The original operating cycle has been changed. 2. Original drive parameters have been changed.

- Countermeasures**
1. Check the layout of the drive for changed requirements. Do not operate any longer at overload. Risk of damage!
 2. Reset to the original parameters. Check the layout of the drive in the case of changed requirements.

11.5.3 Gearbox-motor unit generates vibrations

- Status** Audible or tactile vibrations occur on the gearbox-motor unit.
- Possible causes**
1. Driven machine elements are insufficient, not balanced or insufficiently coupled.
 2. Gearbox-motor bearings worn or defective. Available bearing lifetime or grease lifetime elapsed.
 3. Gearbox-motor fixing are loosened.
 4. Drive system is instable from a control point of view.
- Countermeasures**
1. Check balance of driven machine elements. Check the key and the keyway. In the case of damage, contact Rexroth Service.
 2. Check the gearbox for damage. In the case of loss, contact Rexroth Service.
 3. Fasten motor properly and check for damage. In the case of loss, contact Rexroth Service.
 4. Check parameters of the drive system (motor and encoder data). Observe the notes in the documentation for the drive controller.

11.5.4 Specified position is not attained

- Status** The positioning command of the control unit is not precisely executed, or not at all. No malfunction display on the device controller or the control.
- Possible causes**
1. Motor drive shaft machine element connection loose.
 2. Motor shaft - gearbox connection loose.
 3. Gearing defective.
- Countermeasures**
1. Check the mechanical connection. Do not continue to use damaged parts.
 2. Check the mechanical connection. Do not continue to use damaged parts.
 3. Change of gearbox necessary. In the case of a malfunction, contact Bosch Rexroth Service.

12 Environmental protection and disposal

12.1 Environmental protection

Production processes	The products are manufactured in energy- and resource-optimized production processes which allow re-using and recycling the resulting waste. We regularly try to replace pollutant-loaded raw materials and supplies by more environment-friendly alternatives.	
No release of hazardous substances	Our products do not contain any hazardous substances which may be released in case of appropriate use. Normally, our products will not have any negative influences on the environment.	
Significant components	Significant components of our products are:	
	Electronic devices <ul style="list-style-type: none"> • Steel • Aluminum • Copper • Plastics • Electronic components 	Motors <ul style="list-style-type: none"> • Steel / Stainless steel • Aluminum • Copper • Brass • Magnetic materials • Elektronic components

12.2 Disposal

Return of products	<p>Our products can be returned to us for disposal free of charge. However, this requires that the products be free from oil, grease or other dirt.</p> <p>Furthermore, the products returned for disposal may not contain any undue foreign material or foreign components.</p> <p>Deliver the products "free domicile" to the following address:</p> <p style="text-align: center;">Bosch Rexroth AG Electric Drives and Controls Buergermeister-Dr.-Nebel-Straße 2 97816 Lohr am Main, Germany</p>
Packaging	<p>Packaging materials consist of cardboard, wood and polystyrene They can be recycled anywhere without any problem.</p> <p>For ecological reasons, please refrain from returning the empty packages to us.</p>
Batteries and accumulators	<p>Batteries and accumulators can be labeled with this symbol.</p> <p></p> <p>The symbol indicating "separate collection" for all batteries and accumulators is the crossed-out wheeled bin.</p> <p>End users in the EU are legally bound to return used batteries and accumulators. Outside the validity of the EU Directive 2006/66/EC, the particularly applicable regulations must be followed.</p> <p>Batteries and accumulators can contain hazardous substances which can harm the environment or people's health when improperly stored or disposed of.</p> <p>After use, the batteries or accumulators contained in Rexroth products must be properly disposed of according to the country-specific collection systems.</p>

- Recycling** Most of the products can be recycled due to their high content of metal. In order to recycle the metal in the best possible way, the products must be disassembled into individual assemblies.
- Metals contained in electric and electronic assemblies can also be recycled by means of special separation processes.
- Plastic parts of the products may contain flame retardants. These plastic parts are labeled according to EN ISO 1043. They have to be recycled separately or disposed of according to the applicable legal provisions.

13 Service and support

Our worldwide service network provides an optimized and efficient support. Our experts offer you advice and assistance should you have any queries. You can contact us **24/7**.

Service Germany Our technology-oriented Competence Center in Lohr, Germany, is responsible for all your service-related queries for electric drive and controls.

Contact the **Service Hotline** and **Service Helpdesk** under:

Phone: **+49 9352 40 5060**
Fax: **+49 9352 18 4941**
E-mail: service.svc@boschrexroth.de
Internet: <http://www.boschrexroth.com>

Additional information on service, repair (e.g. delivery addresses) and training can be found on our internet sites.

Service worldwide Outside Germany, please contact your local service office first. For hotline numbers, refer to the sales office addresses on the internet.

Preparing information To be able to help you more quickly and efficiently, please have the following information ready:

- Detailed description of malfunction and circumstances
- Type plate specifications of the affected products, in particular type codes and serial numbers
- Your contact data (phone and fax number as well as your e-mail address)

Index

A

Accumulators.....	71
Ambient temperature.....	21
Application notes.....	21
Assembly.....	63
Assembly of output elements.....	23

B

Barcode label.....	59
Batteries.....	71
Bearing lifetime.....	23

C

Calculation of average speed.....	33
Combinations of GTE with motors.....	25
Commissioning log.....	67
Contained substances see "Significant components".....	71
Continuous operation.....	22
Continuous operation with pause interval.....	17
Continuous operation without pause interval (S1).....	18

D

Deactivation.....	68
Degree of protection.....	21
Derating.....	21
Dimensioning.....	17
Dimensioning criteria.....	18
Disassembly.....	68
Disposal.....	71
Drive system.....	7
Drive-determined sizes.....	18

E

Electric drive system.....	7
Environmental protection.....	71
Explosion protection ATEX.....	22
Hazardous areas.....	22

F

Fields of application.....	1
----------------------------	---

G

Gearbox mounting.....	66
Gearboxes Characteristic curves motor-gearbox.....	19
Dimensioning.....	19
Selection.....	19

H

Handling.....	59
Hazardous substances.....	71

Helpdesk.....	73
Hotline.....	73
Housing temperature.....	69

I

Inappropriate use.....	6
Consequences, exclusion of liability.....	5
Installation altitude.....	21
Installation positions	23
Intended use Introduction.....	5
Intermitted operation.....	21

L

Limiting temperature curves.....	35
----------------------------------	----

M

Maintenance.....	68
Maximum transferable output torque.....	32
Mechanical features.....	23
Mode of functioning.....	1
Motor mounting.....	63
Mounting procedure.....	64

N

Name plate.....	59
-----------------	----

O

Operating conditions.....	21
Operating mode.....	21
Operational reliability.....	1
Original packaging.....	60
Output shaft.....	23
Output torque of 50%.....	33
Output torque of 100%.....	33

P

Packaging.....	71
PELV.....	11
Performance data.....	1
Permitted shaft load.....	41
Production processes.....	71
Protective extra-low voltage.....	11

R

Recycling.....	72
Reduction at higher cycles.....	22
Return of products.....	71

S

Safety instructions for electric drives and controls.....	7
Selection.....	18

Index

Service hotline.....	73
Shaft load.....	23
Significant components.....	71
Skilled personnel.....	63
Start-up.....	67
Storage.....	60
Support.....	73

T

Technical data.....	27
GTE040.....	27
GTE060.....	28
GTE080.....	29
GTE120.....	30
GTE160.....	31
Intermittent and continuous operation.....	27
Technical data at increased lifetime.....	34
Thermal specifications for S1 operation.....	33
Transport.....	60
Triangular operation with pause interval.....	17
Troubleshooting.....	69
Type code	
GTE040.....	53
GTE060.....	54
GTE080.....	55
GTE120.....	56
GTE160.....	57
Type codes.....	53

U

Use.....	5
----------	---

Notes

Bosch Rexroth AG

Electric Drives and Controls

P.O. Box 13 57

97803 Lohr, Germany

Bgm.-Dr.-Nebel-Str. 2

97816 Lohr, Germany

Phone +49 9352 18 0

Fax +49 9352 18 8400

www.boschrexroth.com/electrics



R911308842