

The “New Generation” – ISO Cylinders for a Dynamic Future

Rexroth's new generation of ISO pneumatic cylinders



ISO cylinders

PRA, TRB, and PRE

PRA – PProfile Advanced:

Profile cylinder with a wide range of options

Stroke range: 1 – 2850 mm
 Working pressure: 1.5 to 10 bar
 Size: Ø 32 – 125 mm
 Temperature range: -20°C to +80°C
 Heat-resistant up to + 150°C



TRB – Tie Rod Basic:

Tie rod cylinder with a wide range of options

Stroke range: 1 – 2850 mm
 Working pressure: 1.5 to 10 bar
 Size: Ø 32 – 125 mm
 Temperature range: -20°C to +80°C
 Heat-resistant up to +150°C



PRE – PProfile Economic:

Inexpensive basic variant with additional stroke option that can be configured

Stroke range: 1 – 2850 mm
 Working pressure: 1.5 to 10 bar
 Size: Ø 32 – 125 mm
 Temperature range: -20°C to +80°C



“New Generation” – universal and secure in the future

Our new PRA, TRB, and PRE cylinder series represent consistent further development of our proven ISO cylinder with tie rods or compact profile designs. It is the classic solution for numerous tasks and applications in nearly all industries – available worldwide to a uniform standard.

Considerably lighter, more efficient, and with perfect cushioning

PRA, TRB, and PRE are convincing examples that there is always room for improvement. Besides offering perfection down to the last detail and an optimized material design, the new generation of cylinders particularly impresses, thanks to the improvements made to the cushioning system.

- Less noise and vibration for better work environment
- Shorter cycle times result in higher productivity
- Weight reduction results in lighter machines

The enormous variety within the series is accompanied by comprehensive standard versions, far-reaching individual configu-



ration options and a wide array of accessories: all more reasons to choose the new generation. These cylinders are extremely versatile in their application and were developed with trend-setting concepts that ensure the product's future.



Our ISO cylinders are a perfect fit for any sector: general automation technology, machinery and plant construction, as well as applications for specific industries.

- Attractive, uniform appearance throughout the entire cylinder series for appealing machine design
- Reinforced polymer piston for high performance with consistent quality

- Improved absorption of residual energy due to elastic cushioning element for even less vibration and a lower noise level
- Numerous space-saving mounting options for sensors and proximity switches offer a high level of flexibility

- Improved configurator and CAD applications in the Rexroth online catalog enable fast, easy configuration and machine planning – also for additional options, accessories, and spare parts

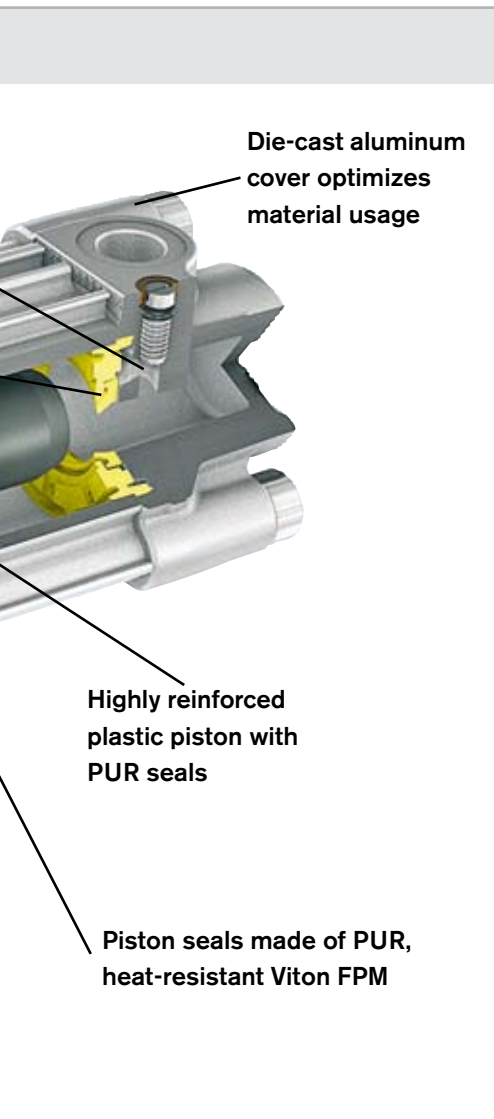

Variants, accessories, sensors

1. Range of variants, standard and configurable versions

Standard PRA/TRB versions: with magnetic piston, with or without pneumatic cushioning, with simple or continuous piston rod, heat-resistant, ATEX; **additional TRB feature:** trunnion mounting, with low-friction piston; **PRE:** with magnetic piston, pneumatic cushioning and simple piston rod.

Configurable PRA/TRB versions: without magnetic piston, extended piston rod, metal scraper, modular seal system, heat-resistant up to 150°C, trunnion mounting; **additional TRB feature:** metal piston (X-sensor), with low-friction piston; **PRE:** stroke length and piston rod extension can be configured.

2. Comprehensive accessories

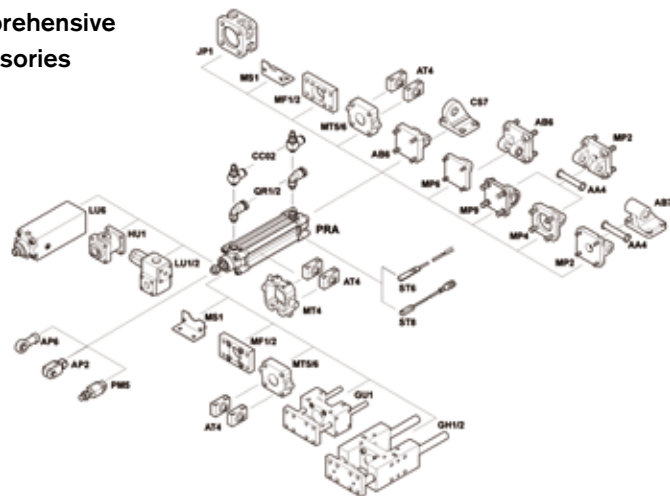

3. Wide range of sensors

	PRA	TRB	PRE
ST6 series for direct mounting	x	–	x
ST6 series with clamp mounting	–	x	x
ST8 series with clamp mounting	x	x	x
ST1 series with clamp mounting	x	x	–
ST2 series with clamp mounting	x	–	–
SN6 series with clamp mounting	–	x	–

Standard cylinders – setting new standards

Advantages that pay off

The improved pneumatic cushioning stands out among the many advantages that distinguish the new ISO cylinder generation. It improves control characteristics through a more precise adjustment of the cushioning screw and allows shorter cycle times due to higher air discharge volumes. The new cushioning also reduces vibrations and noise to a minimum.

- Reduced weight as a design with optimized material usage allows for more cost-effective machine constructions
- Standardized dimensions, connection dimensions and mounting accessories according to DIN ISO 15552 for manufacturer-independent constructions
- A wide spectrum of products offers flexibility when choosing a cylinder and machine design
- Better control characteristics and shorter cycle times due to optimized pneumatic cushioning
- Precise and simple adjustment of the cushioning screw

Special characteristics, qualities, materials, equipment details (example: PRA)

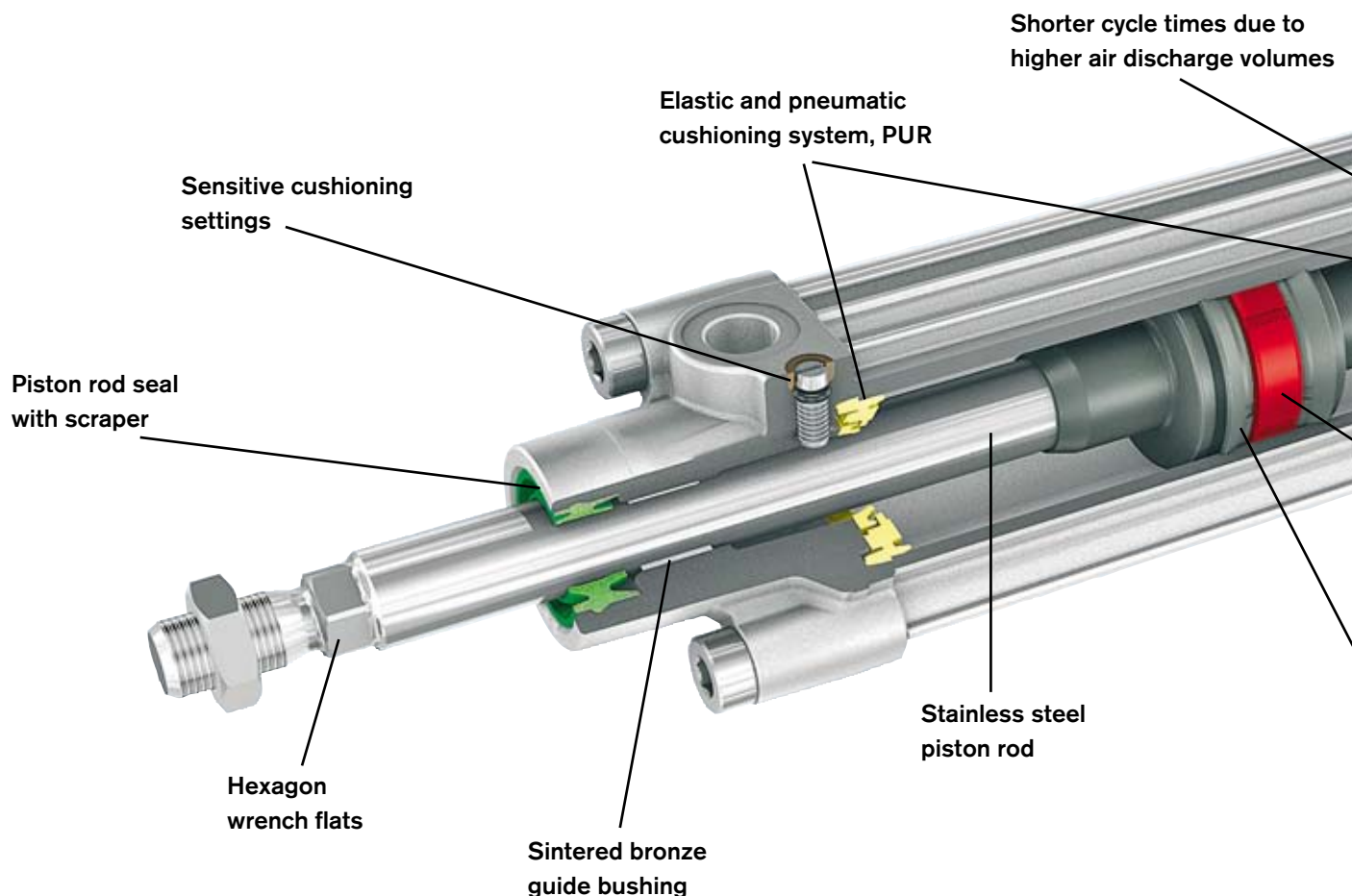

Bosch Rexroth AG
Pneumatics
Ulmer Straße 4
D - 30880 Laatzen
Phone +49 511 2136-0
Fax +49 511 2136-269
sales-pneumatics@boschrexroth.de
www.boschrexroth.com/pneumatics

Your contact:

Canada

Bosch Rexroth Canada Corp.
3426 Mainway Drive
Burlington, Ontario L7M 1A8
Tel. +1 905 335-5511
Fax +1 905 335-4184

Australia

Bosch Rexroth Pty. Ltd.
3 Valediction Road
Kings Park NSW 2148
Sydney
Tel. +61 2 9831-7788
Fax +61 2 9831-5553

U.S.A.

Bosch Rexroth Corp.
1953 Mercer Road
Lexington, KY 40511-1021
Kentucky
Tel. +1 859 254-8031
Fax +1 859 254-4188

Great Britain

Bosch Rexroth Ltd.
Broadway Lane
South Cerney
Cirencester, GL7 5UH
Gloucestershire
Tel. +44 1285 86-3000
Fax +44 1285 86-3003

Further contacts:
www.boschrexroth.com/addresses

The data specified above only serve to describe the product. No statements concerning a certain condition or suitability for a certain application can be derived from our information. The given information does not release the user from the obligation of own judgement and verification. It must be remembered that our products are subject to a natural process of wear and aging.

© This document, as well as the data, specifications and other informations set forth in it, are the exclusive property of Bosch Rexroth AG. Without their consent it may not be reproduced or given to third parties.

Subject to modification.
Printed in Germany.
Order no.
R499050813/2008-12/EN